



200177

Mallette spéciale carreleur

Tiler box

16 pcs

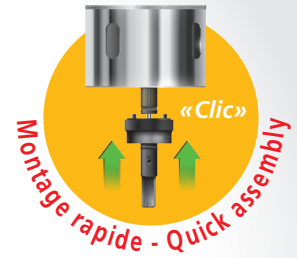
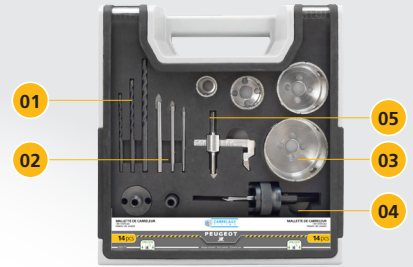

NEW
2021

- 01 3 Forets spéciaux pour carreaux / 3 drills specials for tiles
- 02 3 forets spéciaux pour verres / 3 drills specials for glass
- 03 4 Scies trépan acier avec carbure de tungstène / 4 hole saw with tungsten carbide
- 04 Support de trépan à montage instantané et guide de perçage avec 2 adaptateurs + clé allen / Quick release hole saw guide with 2 adaptators + allen key
- 05 Mèche extensible à vis 23 à 93 mm de perceuse pour carreau / Extensible tile drill 23 to 93 mm with screw for electric drill
- 06 Chatterton, protection du carreau au perçage / Chatterton to prevent tile breaking

Modèle déposé - Design patented

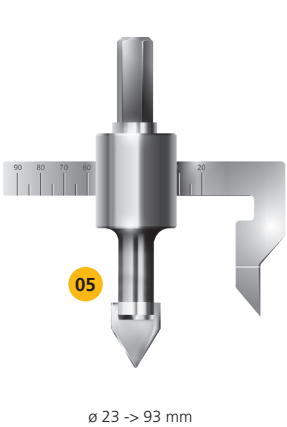

∅ 23 -> 93 mm

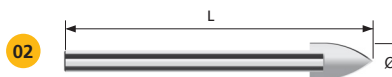

∅ (mm)	L (mm)	Pcs
5	70	x 1
6	75	x 1
8	85	x 1

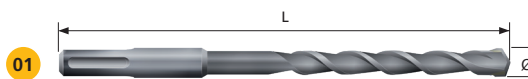

∅ (mm)	L (mm)	Pcs
5	85	x 1
6	100	x 1
8	120	x 1



Montage instantané
Quick release

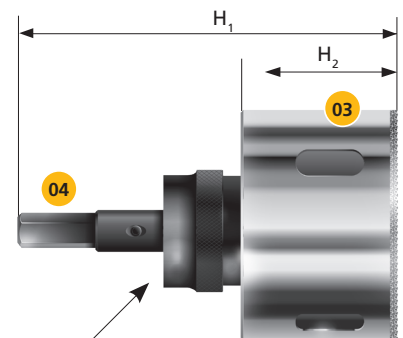

∅ (mm)	H1 (mm)	H2 (mm)
22	125	120
35	125	112
54	125	112
67	105	112

Informations logistiques - Logistic information

Usage - Use

Courant - Common

Dimensions produit - Product size

220x235x100 mm

Poids - Weight

1,61 kg

Gencod - EAN Barcode

