



EnergySaw-185ASP



132007-A-20230612 Peugeot Outillage

FR MANUEL D'UTILISATION (Notice originale):
NL HANDBOEK (Vertaling van het oorspronkelijke):
ES MANUAL (Traducción del original):
PT MANUAL (Tradução do manual original):
IT MANUAL (Traduzione dell'avvertenza originale):
EN USING MANUAL (Original manual translation):

Scie de table et d'établi
Tabel Saw en werkbank
Sierra de mesa y banco de trabajo
Serra e bancada da tabela
Sega da tavolo e banco da lavoro
Table and Workbench saw



A

Description et repérage des organes de la machine Description and location of machine parts

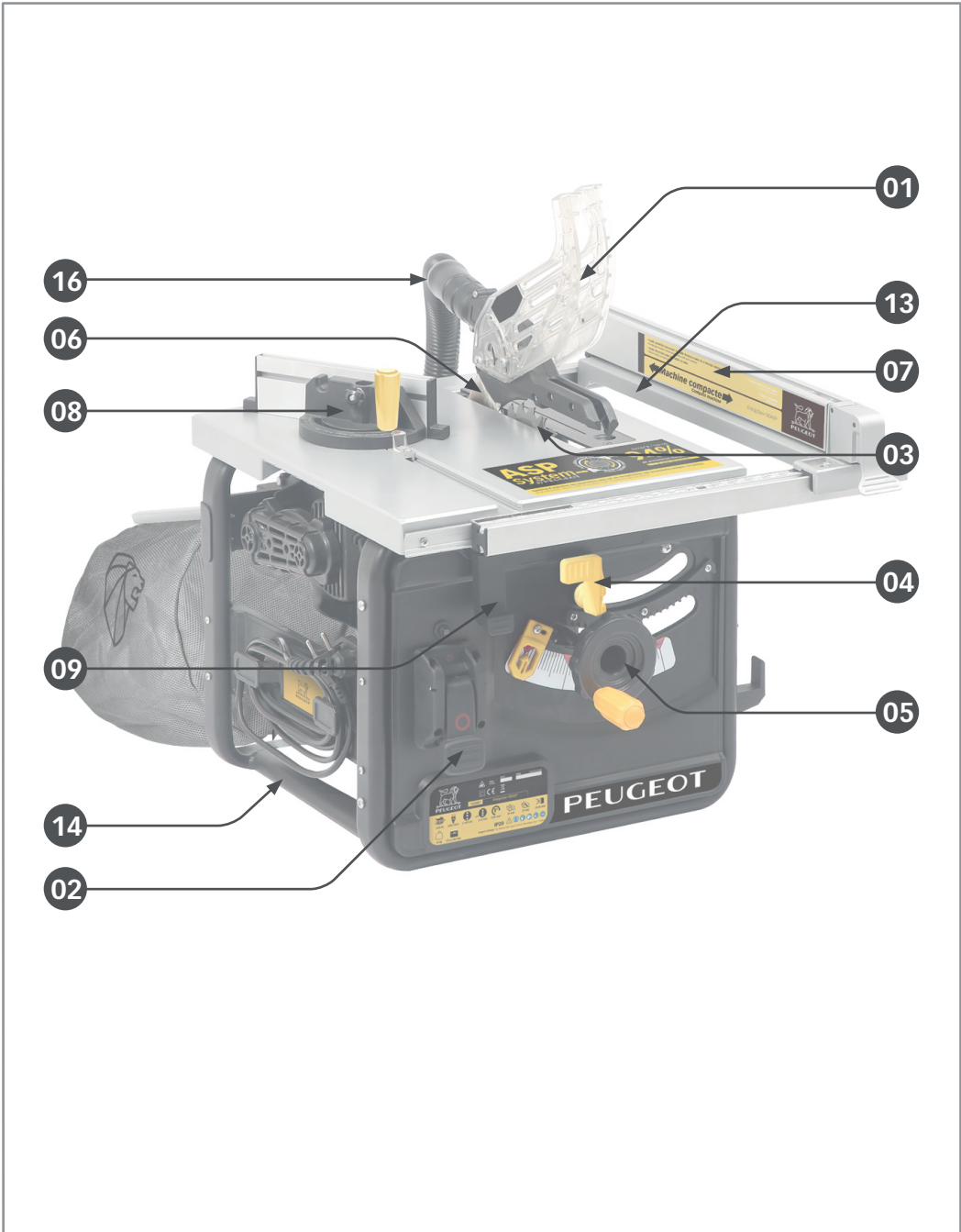

C

Contenu du carton Contents of box



07



15

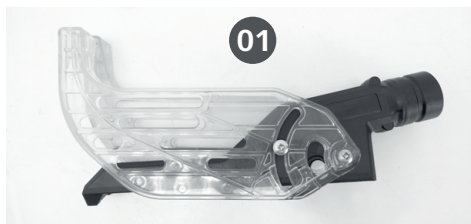

01



08



18



17



16



Points de collecte sur www.quefaire.net/mesdechets.fr
Privilégiez la réparation ou le don de votre appareil !



D

Assemblage de la machine Machine assembly



02

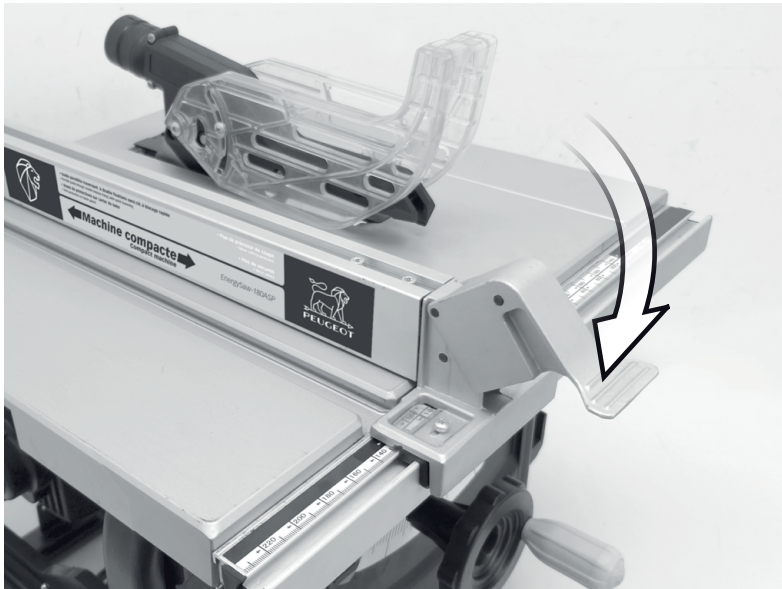
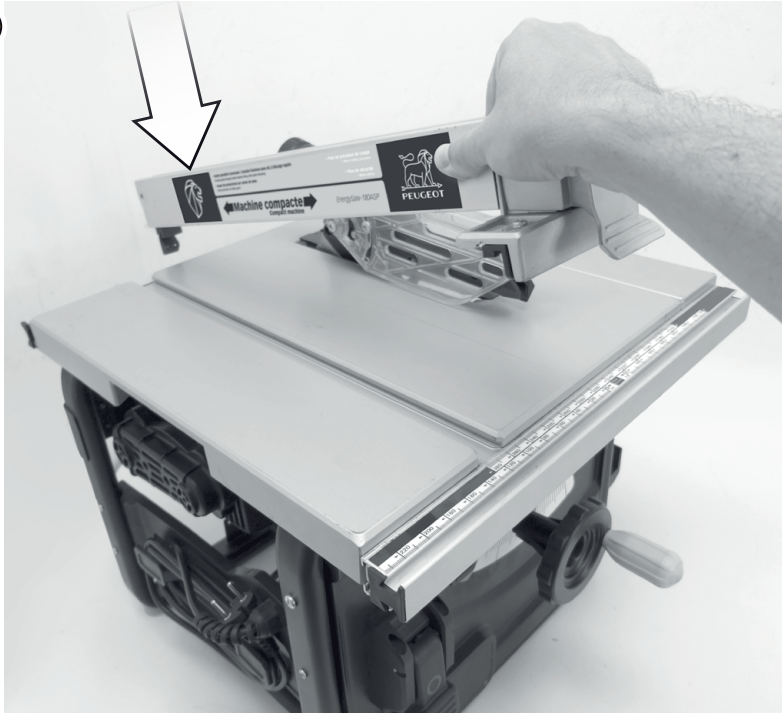

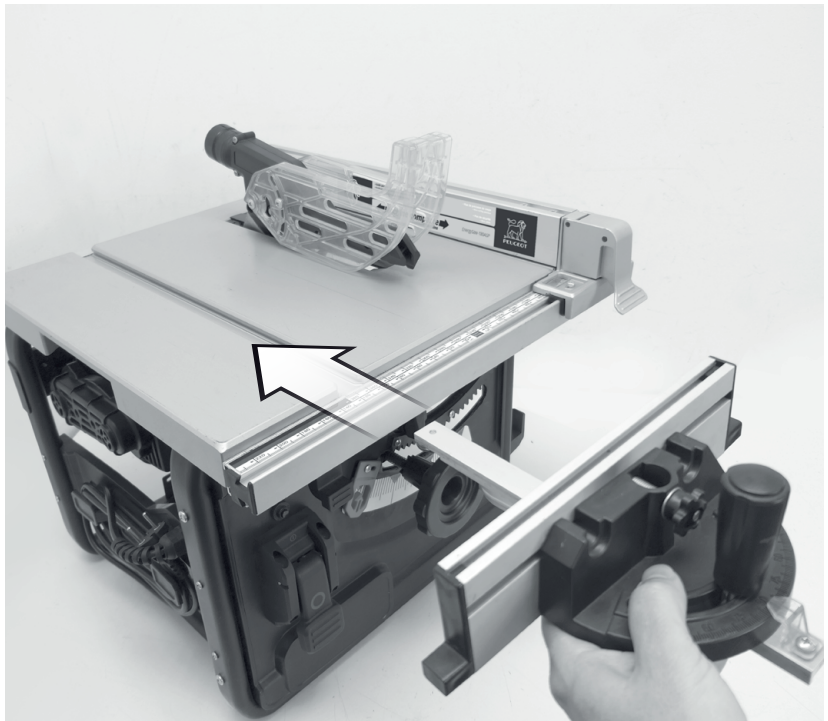
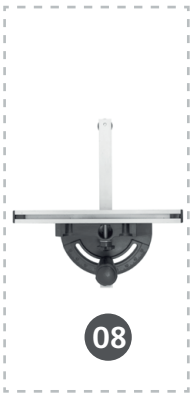
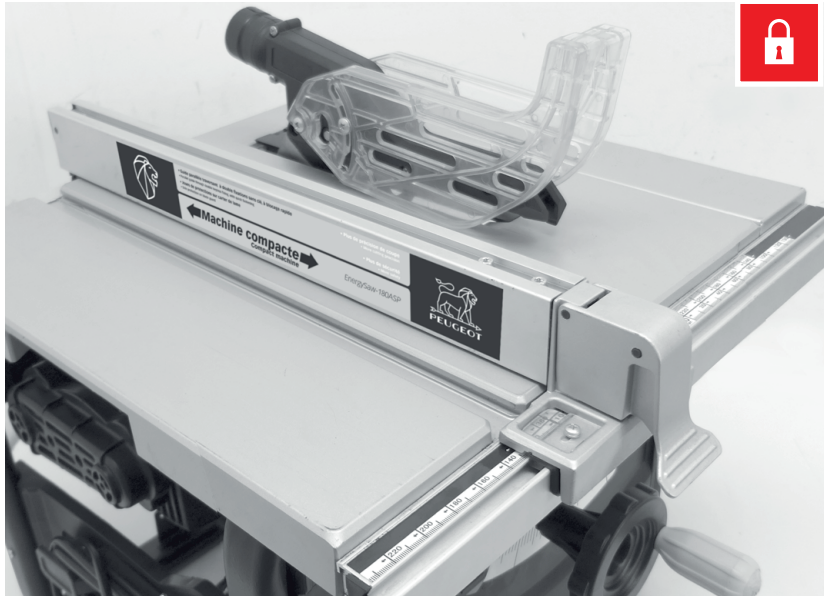



Insérer le carter
(photo ①)

Insert the housing
(photo ①)

05

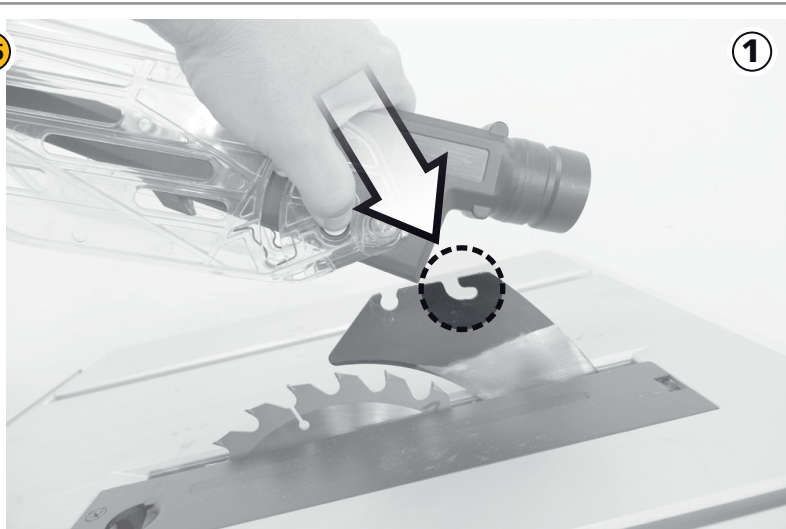

Appuyer sur
le loquet pour
déverrouiller
(photo ②)

Press the latch to
unlock
(photo ②)

Insérer dans le trou de blocage.
(photo ③)

Insert into locking hole.
(photo ③)



Relacher le loquet, il se bloquera automatiquement
(photo ④)

Release the latch, it will lock automatically
(photo ④)

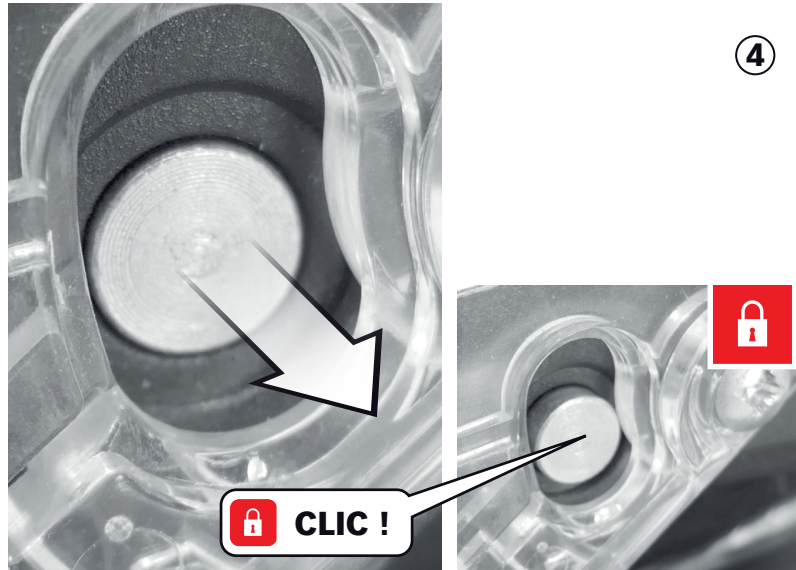

Assemblage du tuyau d'aspiration des poussières

Montage van de stofafzuigleiding
Montaje del tubo de extracción de polvo
Montagem do tubo de extração de pó
Montaggio del tubo di aspirazione della polvere
Assembling the dust extraction pipe

16



06

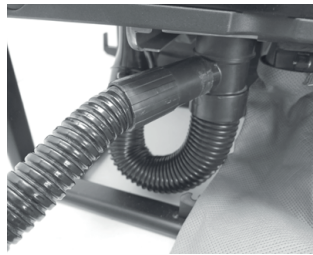
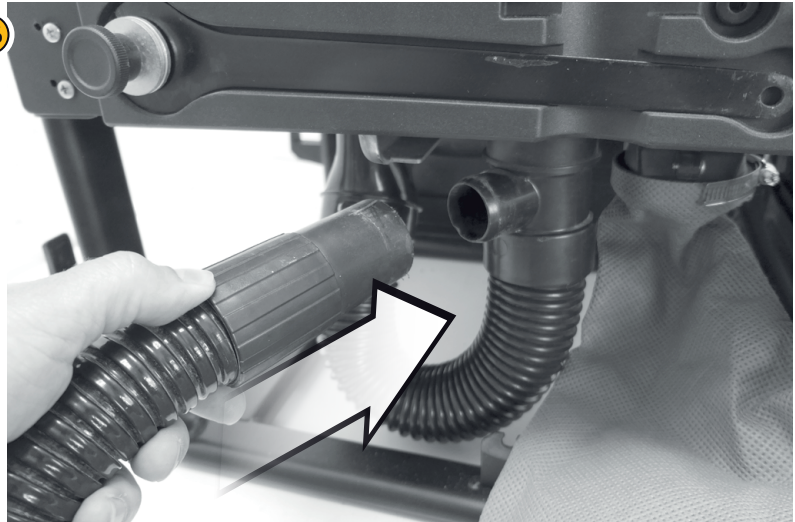

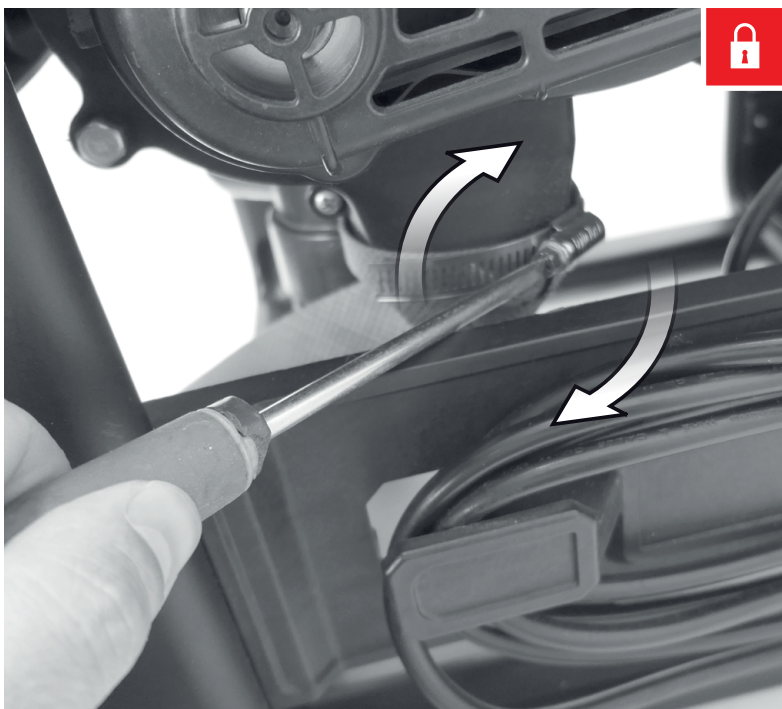
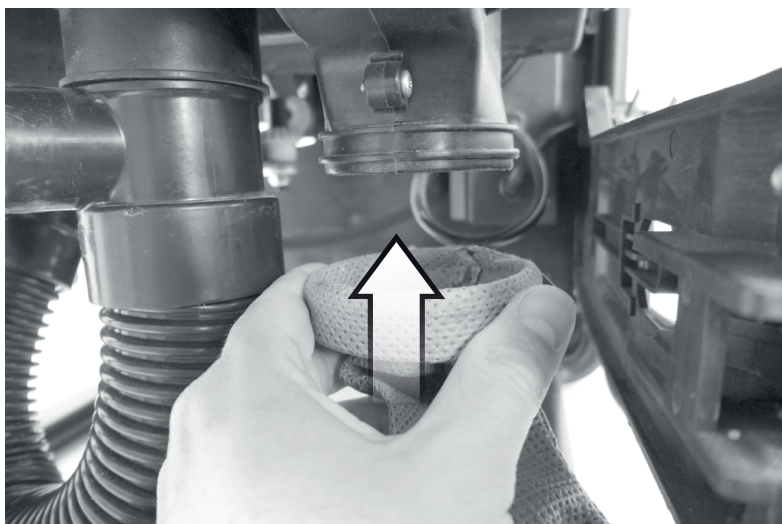

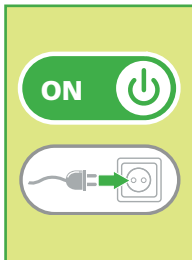

01



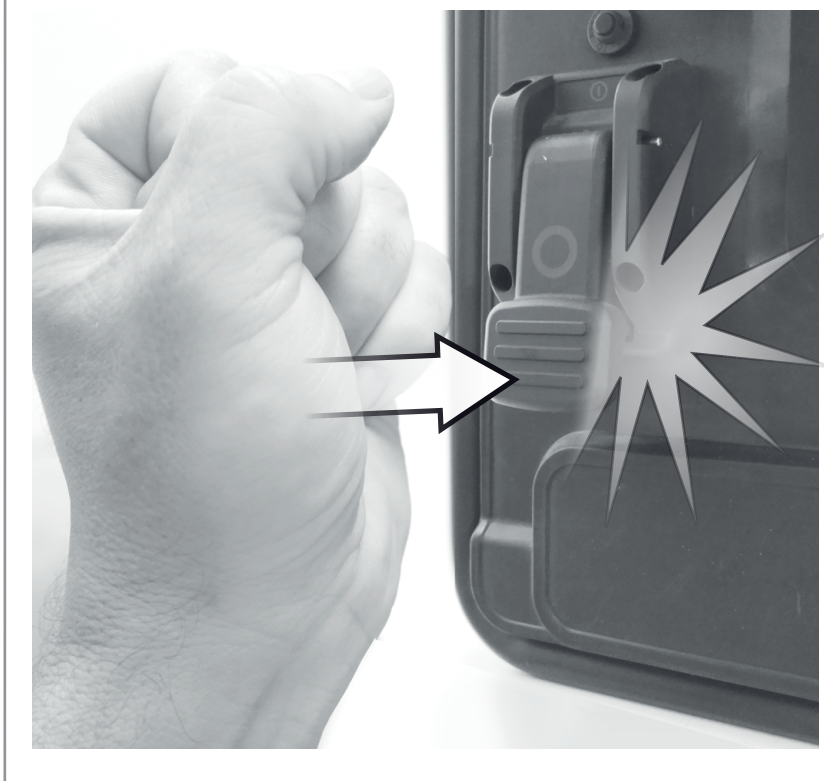

Protection thermique manuelle

Handmatige thermische beveiliging
 Protección térmica manual
 Protezione termica manuale
 Proteção térmica manual
 Manual Thermal protection

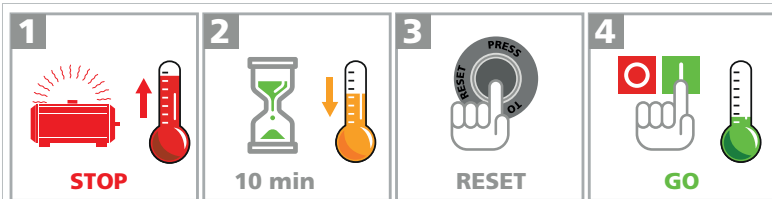

FR Cette machine est équipée d'une protection thermique manuelle. En cas de surchauffe du moteur celui-ci s'arrête automatiquement (1). Pour le redémarrer, il faut attendre qu'il refroidisse (2), enclencher le bouton de réarmement (3) et rallumer le moteur (4).

EN This machine is equipped with manual thermal protection. In case of overheating of the engine it will stop automatically (1). To restart it, wait until it can cool down (2), engage the reset button (3) and restart the engine (4).

ES Esta máquina está equipada con protección térmica manual. En caso de sobrecalentamiento del motor, se detendrá automáticamente (1). Para reiniciarlo, espere hasta que se enfríe (2), active el botón de reinicio (3) y reinicie el motor (4).

IT Questa macchina è dotata di protezione termica manuale. In caso di surriscaldamento del motore si arresterà automaticamente (1). Per riavviarlo, attendere che si raffreddi (2), inserire il pulsante di ripristino (3) e riavviare il motore (4).

PT Esta máquina está equipada com proteção térmica manual. Em caso de superaquecimento do motor, ele pára automaticamente (1). Para reiniciá-lo, aguarde até que ele esfrie (2), pressione o botão de reinicialização (3) e reinicie o motor (4).

NL Deze machine is uitgerust met handmatige thermische beveiliging. Bij oververhitting van de motor zal deze automatisch stoppen (1). Wacht om hem te herstarten tot hij kan afkoelen (2), druk op de resetknop (3) en start de motor opnieuw (4).

①

**1- Déverrouiller
l'inclinaison de lame**

1- Ontgrendelen
helling van het mes
1-desbloquear
inclinación de la hoja
1-desbloquear
inclinação da lâmina
1- bloccare
inclinazione della lama
1- Unlock the blade
tilting knob

02

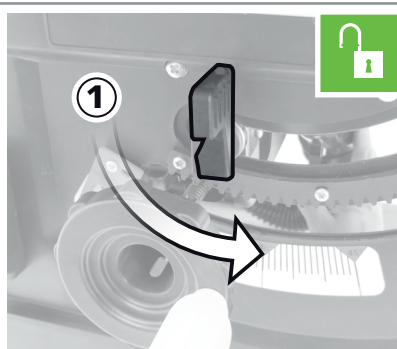
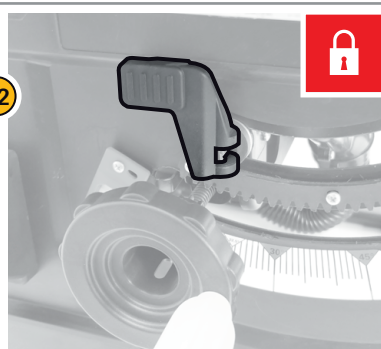

②

**2- Pousser la
molette vers l'avant**

2- Duw het wiel naar
voren
2- Empuje la rueda
hacia adelante
2- Empurre a roda
para a frente
2- Spingere la ruota
in avanti
2- Push the wheel
forward

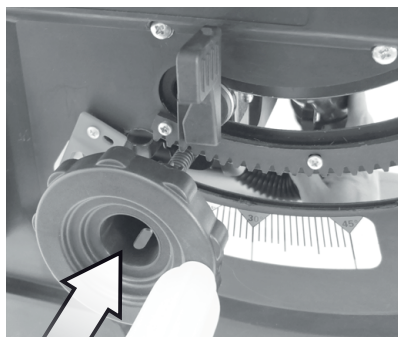

②

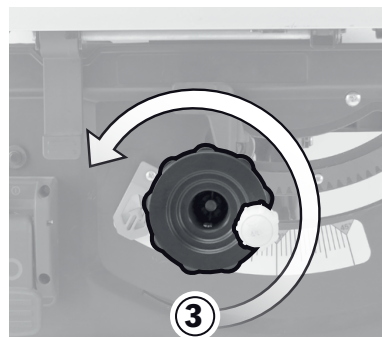

③

③

**3- Tourner la
molette jusqu'à
l'inclinaison désirée**

3- Draai het wiel naar
de gewenste helling
3- Gire la rueda a la
inclinación deseada
3- Gire a roda para a
inclinação desejada
3- Ruotare la ruota
fino all'inclinazione
desiderata
3- Turn the wheel to
the desired inclination

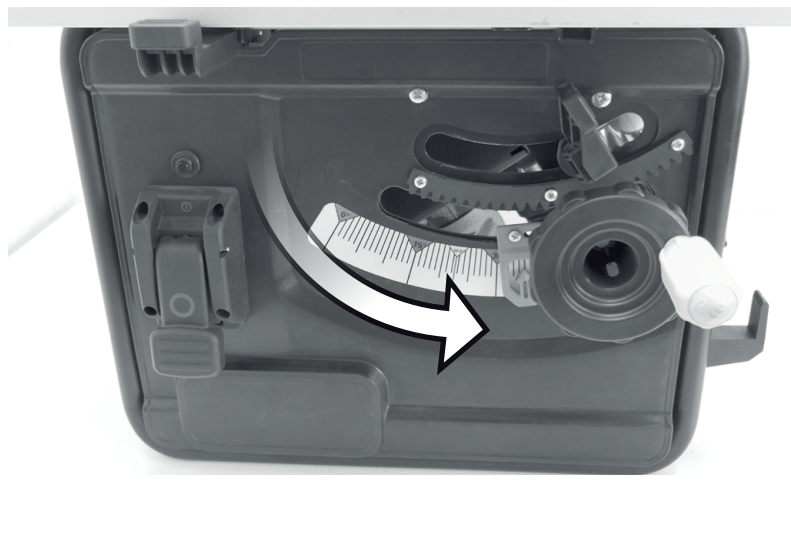

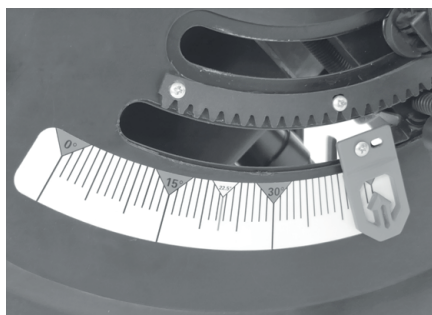
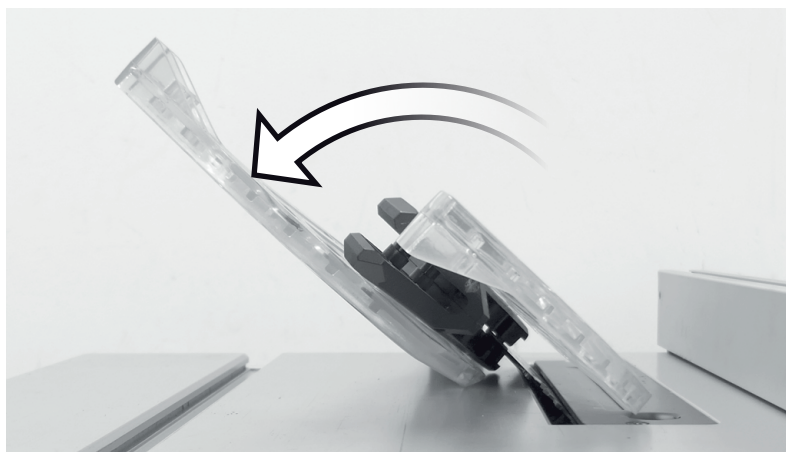

④

4- Verrouiller l'inclinaison de lame

- 4- Slot helling van het mes
- 4- Cerrar inclinación de la hoja
- 4- Trancar inclinação da lâmina
- 4- Serratura inclinazione della lama
- 4- Lock the blade tilting knob



④

03

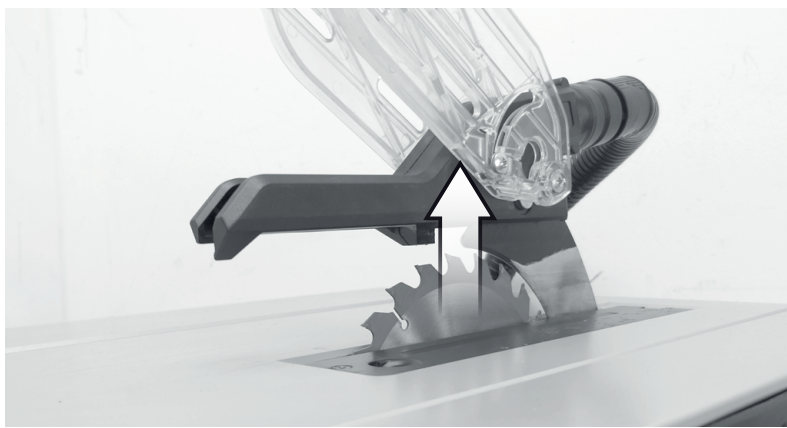
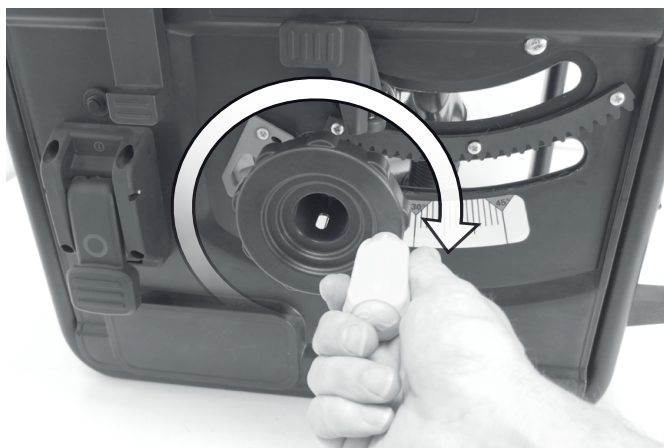

04



05

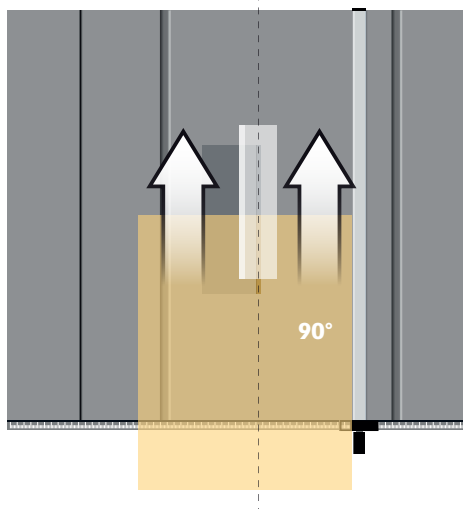

07

05

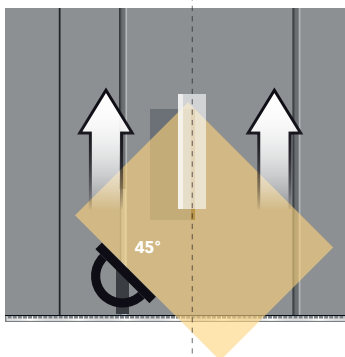

08



Loquet de verrouillage de l'extension de table

Vergrendelings-
vergrendeling
tafelverlenging
Pestillo de blo-
queo de extensión
de mesa
Trava de trava-
mento da exten-
são da mesa
Chiusura a scatto
dell'estensione del
tavolo
Table Extension
Locking Latch

06

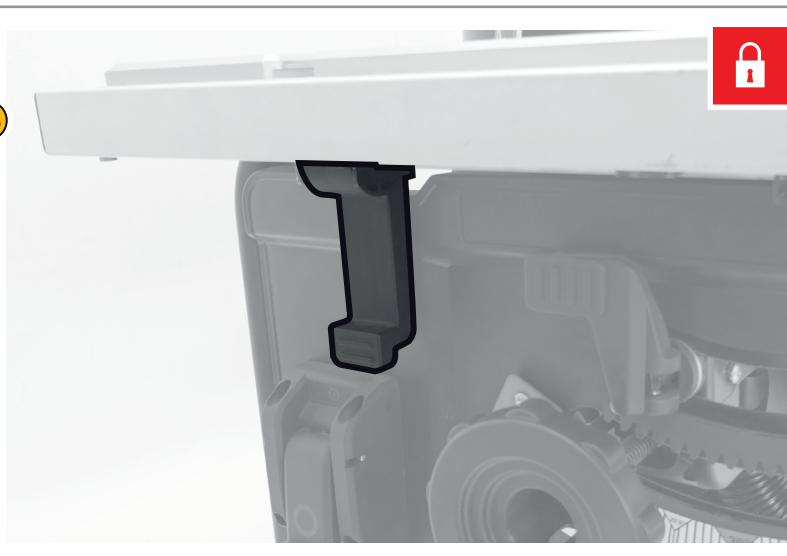

06

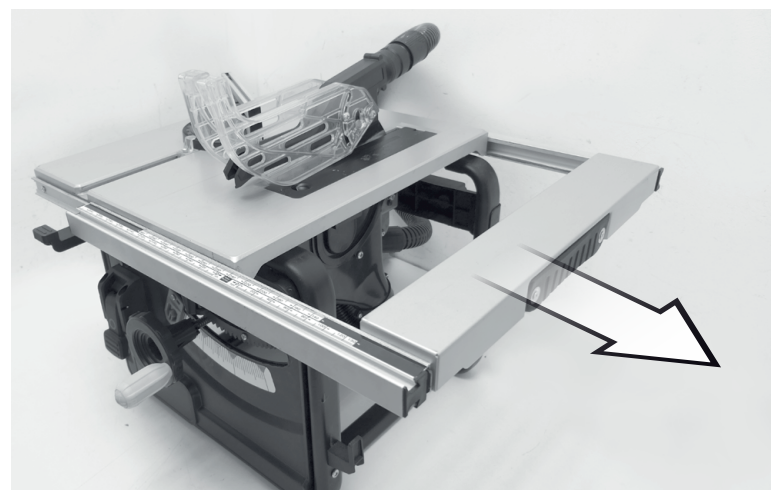
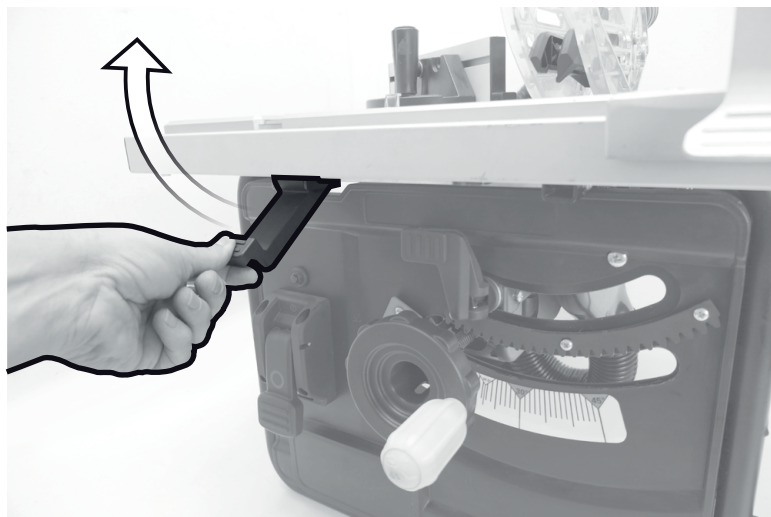





Avant toute opération sur la maintenance de la machine, la débrancher du secteur IMPÉRATIVEMENT !

Voor elke operatie: op onderhoud van de automaat, haal de stekker uit het stopcontact VERPLICHT!

Antes de cualquier operación en mantenimiento de la máquina, desconectarlo de la red ¡IMPERATIVAMENTE!

Antes de qualquer operação em manutenção da máquina, desligue-o da rede IMPERATIVAMENTE!

Prima di qualsiasi operazione in manutenzione della macchina, scollegarlo dalla rete IMPERATIVAMENTE!

Before any operation on maintenance of the machine, disconnect it from the mains IMPERATIVELY!



01



Enlever le carter en inversant les instructions des pages 7 et 8

Verwijder de behuizing door de instructies op pagina 7 en 8 in omgekeerde volgorde uit te voeren

Retire la carcasa invirtiendo las instrucciones de las páginas 7 y 8

Remova o invólucro invertendo as instruções nas páginas 7 e 8

Rimuovere l'alloggiamento invertendo le istruzioni a pagina 7 e 8

Remove the housing by reversing the instructions on pages 7 and 8

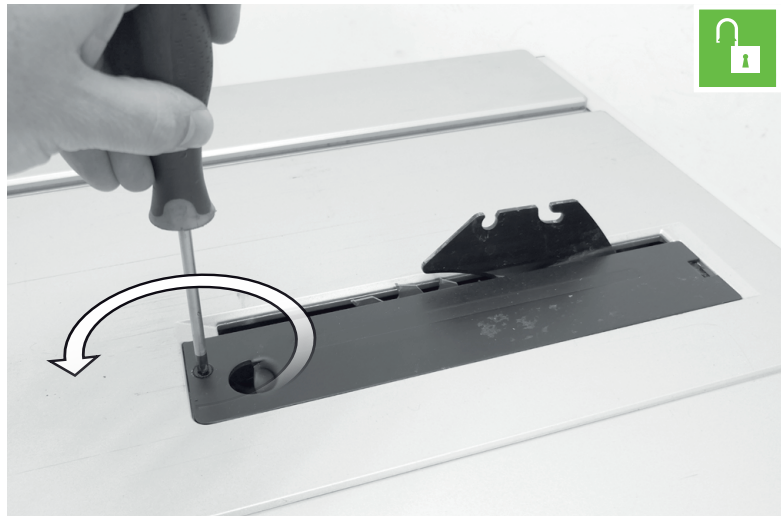

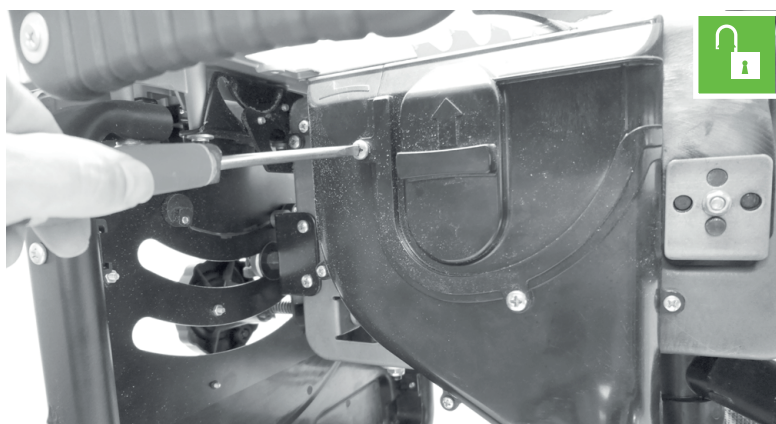

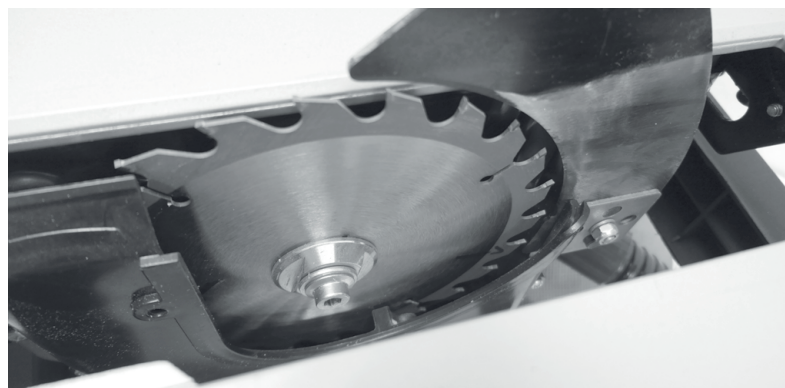
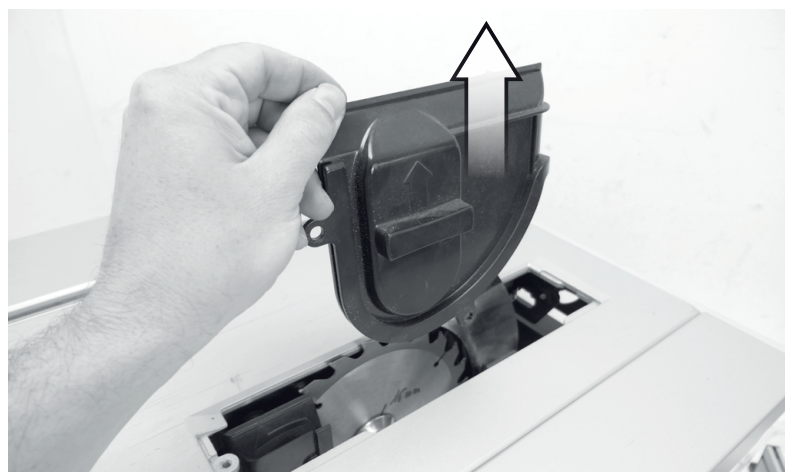
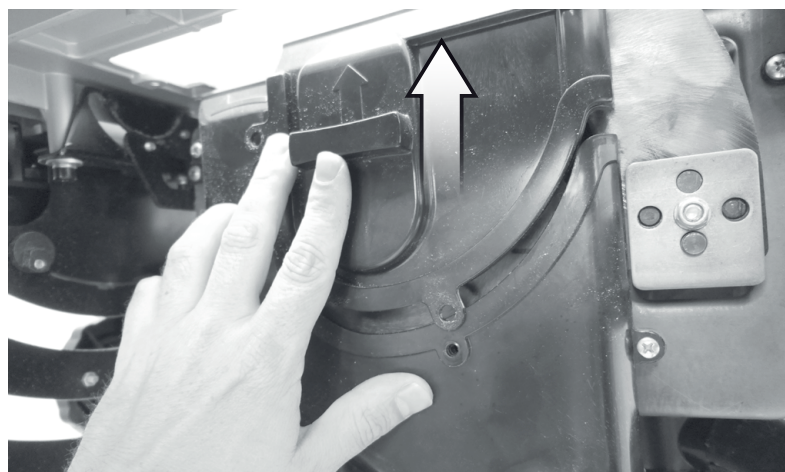

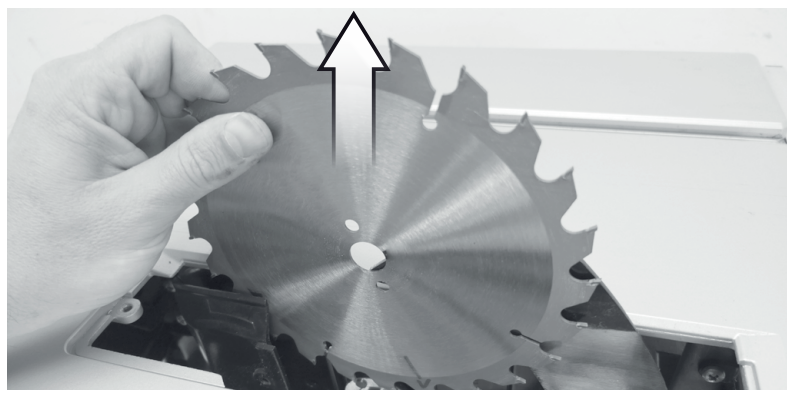
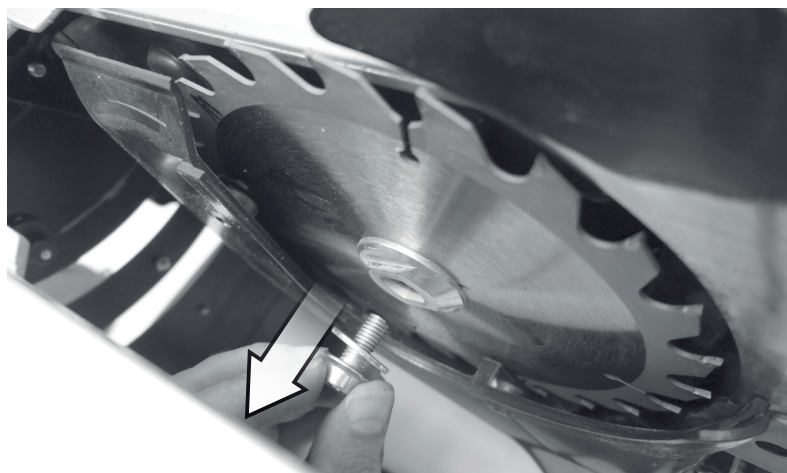
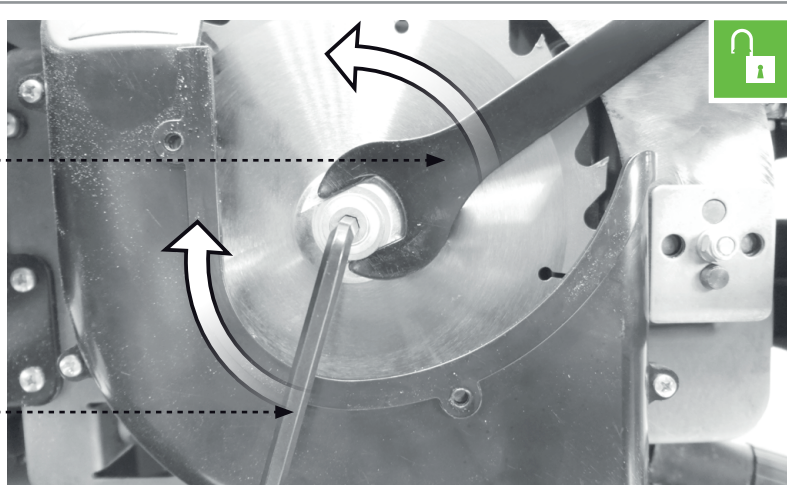
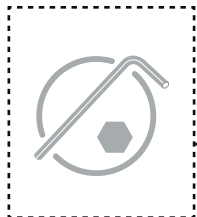

F

Remplacement des consommables

Consumables replacement



Option - Opcional - Opzione - Opção - Optie - Option

801326:

Lame ø 185 x 1,4 x 15,9 mm - 40 T

Blad ø 185 x 1,4 x 15,9 mm - 40 T
 Cuchilla ø 185 x 1,4 x 15,9 mm - 40 T
 Lámina ø 185 x 1,4 x 15,9 mm - 40 T
 Lama ø 185 x 1,4 x 15,9 mm - 40 T
 Blade ø 185 x 1,4 x 15,9 mm - 40 T



G

Entretien, recommandations et conseils

Cleaning and maintenance



Vider le sac très régulièrement !

Leeg de zak zeer regelmatig!
 ¡Vacíe la bolsa con mucha regularidad!
 Esvazie o saco muito regularmente!
 Svuota la borsa molto regolarmente!
 Empty the bag very regularly!

03

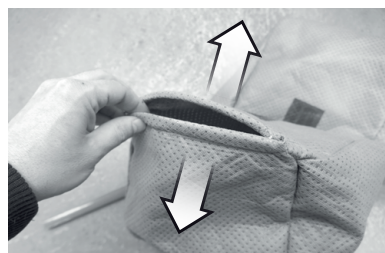
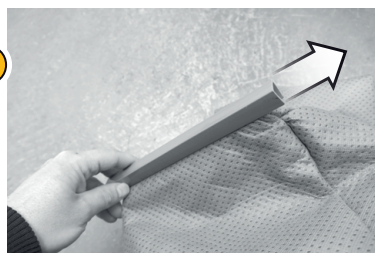

G

Entretien, recommandations et conseils

Cleaning and maintenance

Aspirer régulièrement les résidus de sciure et copeaux

Zuig regelmatig zaagsel en spaanders op
Aspirar regularmente aserrin y virutas
Aspire regularmente serradura e aparas
Aspirare regolarmente segatura e trucioli
Regularly vacuum sawdust and shavings

- Nettoyer et aspirer régulièrement les résidus de bois (particulièrement les grilles de passage d'air pour le refroidissement du moteur), afin d'en conserver l'utilisation optimale et de diminuer son échauffement.

- Reinig en zuig regelmatig houtresten op (met name de luchtdoorlaatroosters voor motorkoeling), om een optimaal gebruik te behouden en oververhitting te verminderen.

- Limpie y aspire regularmente los residuos de madera (en particular las rejillas de paso de aire para la refrigeración del motor), para mantener un uso óptimo y reducir el sobrecalentamiento.

- Limpe e aspire regularmente os resíduos de madeira (especialmente as grelhas de passagem de ar para arrefecimento do motor), de forma a manter um ótimo aproveitamento e reduzir o sobreaquecimento.

- Pulire e aspirare regolarmente i residui di legno (in particolare le griglie di passaggio dell'aria per il raffreddamento del motore), al fine di mantenere un utilizzo ottimale e ridurre il surriscaldamento.

- Clean and vacuum wood residues regularly (especially air passage grids for engine cooling), to maintain its optimal use and reduce its warm-up.

03

Vider le sac très régulièrement !

Leeg de zak zeer regelmatig!
¡Vacíe la bolsa con mucha regularidad!
Esvazie o sacco muito regolarmente!
Svuota la borsa molto regolarmente!
Empty the bag very regularly!



25 kg

04

Transport de la machine
Vervoeren Machine
Transporte de la máquina
Transporte da máquina
Il trasporto della macchina
Transportation of the Machine

x 2

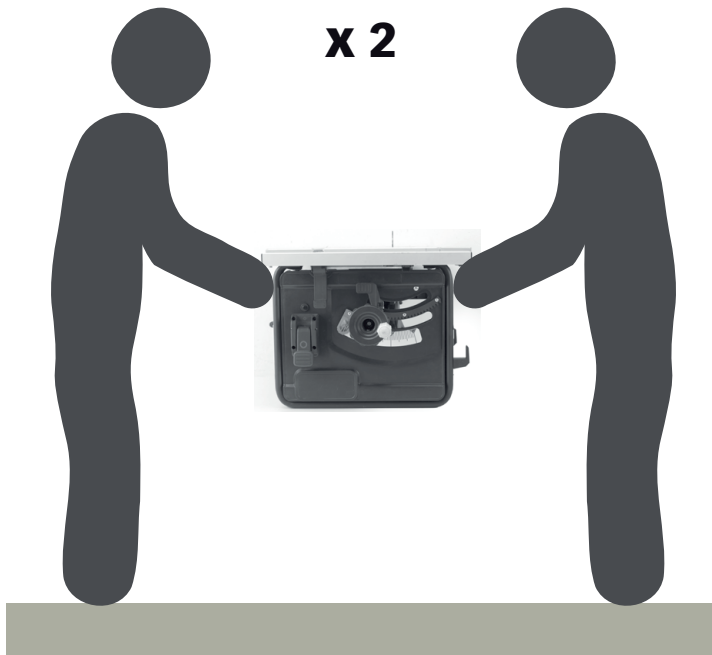

Description et repérage des organes de la machine**FIG. A & B**

- 01 Carter de protection
- 02 Interrupteur arrêt coup de poing
- 03 Lame
- 04 Inclinaison de lame
- 05 Réglage hauteur de coupe
- 06 Couteau diviseur
- 07 Guide parallèle
- 08 Guide d'angle
- 09 Serrage rapide
- 10 Système anti-basculé
- 11 -
- 12 -
- 13 Extensions de table
- 14 Châssis
- 15 Pousoir
- 16 Flexible aspiration

Contenu du carton**FIG. C****Assemblage de la machine****FIG. D**

- 01 Montage du châssis
- 02 Montage des guides
- 03 Montage des extensions
- 04 Montage de la lame
- 05 Montage du carter
- 06 Montage du tuyau d'aspiration

Fonctionnalité de la machine**FIG. E**

- 01 Mise en marche et arrêt
- 02 Inclinaison de la lame
- 03 Réglage hauteur de coupe
- 04 Utilisation du pousoir
- 05 Utilisation des guides
- 06 Utilisation des extensions
- 07 -
- 08 Raccordement à un aspirateur
- 09 -
- 10 -

Remplacement des consommables

- 01 Changement de lame (Fig D)
- 02 -
- 03 -

Entretien, recommandations et conseils

- 01 Ne pas utiliser pour la coupe de bois de chauffage
- 02 Le choix de la lame est important. Adapter la denture au matériau à couper.

- <36 dents = Coupe rapide, délignage, sur bois tendre.

- 36 à 60 dents = Coupe de dérivé du bois (aggloméré, stratifié...). Coupe de bois dur.

- >60 dents = Coupe précise. Coupe de matière plastique. Coupe de petite section.

- 03 Nettoyage
- 04 Transport
- 05 -
- 06 -

Beschrijving en plaatsbepaling van de onderdelen van de machine

FIG. A & B

- 01 Beschermmantel
- 02 Schakelaar noodstop
- 03 Zaagblad
- 04 Kantelhoek van het zaagblad
- 05 Hoogte-instelling van de snede
- 06 Verdeelmes
- 07 Parallele geleider
- 08 Profielgeleider
- 09 Snelle aanscherping
- 10 Anti-kantelsysteem
- 11 -
- 12 -
- 13 Tafelverlengingen
- 14 Chassis
- 15 Drukknop
- 16 Flexibel afzuigen

Inhoud van het karton

FIG. C

Assemblage van de machine

FIG. D

- 01 Montage van het chassis
- 02 Montage van de geleiders
- 03 Montage van de verlengingen
- 04 Montage van het zaagblad
- 05 Montage van het carter
- 06 Montage van de zuigleiding

Functionaliteit van de machine

FIG. E

- 01 Aanzetten en stoppen
- 02 Kantelhoek van het zaagblad
- 03 Hoogte-instelling van de snede
- 04 Gebruik van de drukknoop
- 05 Gebruik van de geleiders
- 06 Gebruik van extensies
- 07 -
- 08 Aansluiting op een stofzuiger
- 09 -
- 10 -

Vervanging van de accessoires

- 01 Verandering van de lamel (Fig D)
- 02 -
- 03 -

Reiniging en onderhoud

- 01 Niet gebruiken om brandhout te zagen
- 02 De keuze van het zaagblad is belangrijk. De tanden moeten aangepast zijn aan het te zagen materiaal.

- <36 tanden = snel zagen, markeren op zacht hout.
 - 36 à 60 tanden= zagen van houtderivaten (spaanderplaat, gelaagd hout...). Zagen van hard hout.
 - >60 tanden = nauwkeurig zagen. Zagen van plastics.
 Zagen van dunne stukken.

- 03 Schoonmaak
- 04 Vervoer
- 05 -
- 06 -

Description and location of machine parts

FIG. A & B

- 01 Protection guard
- 02 Punch mechanical NVR switch
- 03 Blade
- 04 Blade inclination
- 05 Setting cutting height
- 06 Board splitter
- 07 Parallel guide
- 08 Angle guide
- 09 Quick tightening
- 10 Anti-tilt system
- 11 -
- 12 -
- 13 Table extensions
- 14 Chassis
- 15 Pushbutton
- 16 Flexible suction

Contents of box

FIG. C

Assembling the machine

FIG. D

- 01 Mounting of chassis
- 02 Assembly of the guides
- 03 Mounting of extensions
- 04 Blade assembly
- 05 Mounting of guard
- 06 Assembly of the suction pipe

Functions of the machine

FIG. E

- 01 Switch on/off
- 02 Blade inclination
- 03 Setting cutting height
- 04 Use of the pushbutton
- 05 Use of the guides
- 06 Use of extensions
- 07 -
- 08 Connection to a vacuum cleaner
- 09 -
- 10 -

Replacing consumables

- 01 Changing the blade (Fig D)
- 02 -
- 03 -

Cleaning and maintenance

- 01 Do not use for cutting logs
- 02 The choice of blade is important. Adapt the saw teeth to the material to be cut.

- <36 teeth = Rapid cut, edging, on soft wood.
- 36 to 60 teeth = Cutting wood products (chipboard, laminates etc.). Cutting hard wood.
- >60 teeth = Precise cutting. Cutting plastic.

Cutting small sections.

- 03 Cleaning
- 04 Transport
- 05 -
- 06 -

Descripción y localización de los elementos de la máquina

FIG. A & B

- 01 Cárter de protección
- 02 Interruptor parada de golpe
- 03 hoja
- 04 Inclinación de la hoja
- 05 Regulación de la altura de corte
- 06 Cuchillo divisor
- 07 Guía paralela
- 08 Guía angular
- 09 Ajuste rápido
- 10 Sistema anti-inclinación
- 11 -
- 12 -
- 13 Extensiones de la mesa
- 14 Bastidor
- 15 Empujador
- 16 Aspiración flexible

Contenido del cartón

FIG. C

Ensamblaje de la máquina

FIG. D

- 01 Montaje del bastidor
- 02 Montaje de las guías
- 03 Montaje de las extensiones
- 04 Montaje de la hoja
- 05 Montaje del cárter
- 06 Montaje de la tubería de succión

Funcionalidad de la máquina

FIG. E

- 01 Puesta en marcha y parada
- 02 Inclinación de la hoja
- 03 Regulación de la altura de corte
- 04 Utilización del empujador
- 05 Utilización de las guías
- 06 uso de extensiones
- 07 -
- 08 Empalme con un aspirador
- 09 -
- 10 -

Cambio de los consumibles

- 01 Cambio de hoja (Fig D)
- 02 -
- 03 -

Limpieza y mantenimiento

- 01 No utilizar para cortar leña de calefacción
- 02 La elección de la hoja es importante. Adaptar los dientes al material que se tiene que cortar.

- < 36 dientes = Corte rápido, canteado, en madera blanda.
 - 36 a 60 dientes = Corte de derivados de madera (conglomerado, estratificado...). Corte de madera dura.
 - > 60 dientes = Corte preciso. Corte de materias plásticas.

Corte de pequeñas secciones.

- 03 Limpieza
- 04 Transporte
- 05 -
- 06 -

Descrição e identificação dos órgãos

FIG. A & B

- 01 Cárter de proteção
- 02 Interruptor paragem de emergência
- 03 Lâmina
- 04 Inclinação da lâmina
- 05 Ajuste da altura de corte
- 06 Lâmina separadora
- 07 Guia paralela
- 08 Guia angular
- 09 Aperto rápido
- 10 Anti-Tilt sistema
- 11 -
- 12 -
- 13 Extensões de mesa
- 14 Chassis
- 15 Empurrador
- 16 Sucção flexível

Conteúdo da caixa

FIG. C

Montagem da máquina

FIG. D

- 01 Montagem do chassis
- 02 Montagem das guias
- 03 Montagem das extensões
- 04 Montagem da lâmina
- 05 Montagem do cárter
- 06 Montagem do tubo de sucção

Funcionalidade da máquina

FIG. E

- 01 Accionamento e paragem
- 02 Inclinação da lâmina
- 03 Ajuste da altura de corte
- 04 Utilização do empurrador
- 05 Utilização das guias
- 06 Uso de extensões
- 07 -
- 08 Ligação a um aspirador
- 09 -
- 10 -

Substituição de consumíveis

- 01 Substituição da lâmina (Fig D)
- 02 -
- 03 -

Limpeza e manutenção preventiva

- 01 Não utilizar para o corte de madeira de lenha
- 02 A escolha da lâmina é importante. Adaptar os dentes ao material a cortar.

- <36 dentes = Corte rápido, corte longitudinal, em madeira macia.

36 a 60 dentes = Corte de derivados de madeira (aglomerados, estratificados, etc.). Corte de madeira dura.

- >60 dentes = Corte preciso. Corte de matérias plásticas. Corte de pequena secção.

- 03 Limpeza
- 04 Transporte
- 05 -
- 06 -

Descrizione e localizzazione degli organi della macchina

FIG. A & B

- 01 Carter di protezione
- 02 Interruttore arresto di emergenza
- 03 Lama
- 04 Inclinazione della lama
- 05 Regolazione in altezza del taglio
- 06 Coltello divisore
- 07 Guida parallela
- 08 Guida ad angolo
- 09 Serraggio rapido
- 10 Sistema anti-tilt
- 11 -
- 12 -
- 13 Estensioni del tavolo
- 14 Telaio
- 15 Punteria
- 16 -

Contenuto della scatola

FIG. C

Assemblaggio della macchina

FIG. D

- 01 Montaggio delle pile
- 02 Montaggio delle guide
- 03 Montaggio delle estensioni
- 04 Montaggio della lama
- 05 Montaggio del carter
- 06 Montaggio del tubo di aspirazione

Funzionalità della macchina

FIG. E

- 01 Avvio e arresto
- 02 Inclinazione della lama
- 03 Regolazione in altezza del taglio
- 04 Utilizzazione della punteria
- 05 Utilizzazione delle guide
- 06 Uso delle estensioni
- 07 -
- 08 Raccordo ad un aspiratore
- 09 -
- 10 -

Sostituzione dei pezzi di ricambio

- 01 Cambiare la lama (Fig D)
- 02 -
- 03 -

Pulizia e manutenzione

- 01 Non usare per tagliare legna da ardere
- 02 La scelta della lama è importante. Adattare la dentatura al materiale da tagliare.

- <36 denti = Taglio rapido, rifilatura, su legno dolce.
 - da 36 a 60 denti= Taglio del derivato del legno (conglomerato, stratificato...). Taglio del legno duro. - >60 denti = Taglio preciso. Taglio di materie plastiche. Taglio di piccole sezioni.

- 03 Pulizia
- 04 Trasporto
- 05 -
- 06 -



| | |
|---|---|
| <p>EnergySaw-185ASP 132007 JF71801V</p> | <p>Scie de table et d'établi Tabel Saw en werkbank Sierra de mesa y banco de trabajo Serra e bancada da tabela Sega da tavolo e banco da lavoro Table and Workbench saw</p> |
|---|---|

| | | |
|---|--|----------------|
|  | <p>Lame inclinable: Tilting blade: Tilt Blade: Incline la hoja: Incline Blade: Inclinare lama:</p> | <p>0 - 45°</p> |
|---|--|----------------|

| | | |
|---|--|----------------------|
|  | <p>Tension et fréquence assignée: Aangewezen spanning en frequentie: Tensión y frecuencia fijada: Tensão e frequência fixa: Tensione e frequenza assegnata: Nominal frequency and power:</p> | <p>230 V ~ 50 Hz</p> |
|---|--|----------------------|

| | | |
|---|---|---------------------|
|  | <p>Dimensions table: table sizes: Lijstgrootte: Tamaño de la tabla: Tamanho da tabela: Dimensioni tavolo:</p> | <p>445 x 460 mm</p> |
|---|---|---------------------|

| | | | |
|---|--|--|---------------|
|  | <p>Puissance assignée: Onbelast toerental: Potencia fijada: Potência assinada: Potenza assegnata: Nominal power:</p> | <p>S1 SERVICE CONTINU Fonctionnement à charge constante pour atteindre l'équilibre thermique.</p> | <p>1800 W</p> |
|---|--|--|---------------|

| | | |
|--|---|------------------------------------|
|   | <p>Capacités de coupe: Cutting capacities: Snijden capaciteiten: Capacidades de corte: Cortar capacidades: Di taglio:</p> | <p>45° = 42 mm 90° = 30 mm</p> |
|--|---|------------------------------------|

| | | | |
|---|--|--|---------------------------|
|  | <p>Puissance assignée: Onbelast toerental: Potencia fijada: Potência assinada: Potenza assegnata: Nominal power:</p> | <p>S6 SERVICE ININTERROMPU PÉRIODIQUE A CHARGE INTERMITTENTE Répétition de cycles identiques comprenant chacun une période de fonctionnement à charge continue et une période à vide sans période de repos.</p> | <p>2200 W (S6 : 20%)</p> |
|---|--|--|---------------------------|

| | | |
|---|---|----------|
|  | <p>Lire les instructions avant usage : Lees voor het gebruik de instructies : Léase las instrucciones antes de usar : Ler as instruções antes da utilização : Leggere le istruzioni prima dell'uso : Read the instructions before use :</p> | <p>X</p> |
|---|---|----------|

| | | |
|---|---|------------------------------|
|  | <p>Vitesse à vide: Leerlaufdrehzahl: Velocidad vacía: Velocità a vuoto: Velocidade no vácuo: No-load speed:</p> | <p>4800 min⁻¹</p> |
|---|---|------------------------------|

| | | |
|---|--|----------|
|  | <p>Conformité européenne : Voldoet aan de EG-normen : Cumple con las directivas CE : Conforme às normas CE : Conforme alle norme CE : Conforms to EC standards :</p> | <p>X</p> |
|---|--|----------|

| | | |
|---|--|-----------------|
|  | <p>Dimensions lame: Blade sizes: Paneel afmetingen: Dimensiones del panel: Dimensões do painel: Dimensioni del pannello:</p> | <p>ø 185 mm</p> |
|---|--|-----------------|

| | | |
|---|---|----------|
|  | <p>Danger : Gevaar : Peligro : Perigo : Pericolo : Danger :</p> | <p>X</p> |
|---|---|----------|

| | | |
|---|--|------------------|
|  | <p>Alésage lame: Bore: Blade boring: Perforación de la lámina: Furo lâmina: Foro lama:</p> | <p>ø 15,9 mm</p> |
|---|--|------------------|

| | | |
|---|--|----------|
|  | <p>Classe d'isolement : 2 Isolatie Klasse : 2 Aislamiento clase : 2 Isolamento classe :2 Isolamento classe :2 Insulation class : 2</p> | <p>X</p> |
|---|--|----------|

| | | |
|--|-----------|-------|
| | Poids : | 25 kg |
| | Gewicht : | |
| | Peso : | |
| | Peso : | |
| | Peso : | |
| | Weight : | |

| | |
|--------------|---|
| IP 20 | X |
|--------------|---|

| | | |
|---------------------------|---------------------------------|-----------|
| | Niveau de pression acoustique : | 96 dB (A) |
| | Niveau akoestische druk : | |
| | Nivel de presión acústica : | |
| | Nível de pressão acústica : | |
| | Livello di pressione acustica : | |
| Acoustic pressure level : | | |

| | | |
|------------------------|----------------------------------|------------|
| | Niveau de puissance acoustique : | 109 dB (A) |
| | Niveau akoestisch vermogen : | |
| | Nivel de potencia acústica : | |
| | Nível de potência acústica : | |
| | Livello di potenza acustica : | |
| Acoustic power level : | | |

NIVEAU SONORE D'EMISSION:

A VIDE

Pression acoustique LpA poste opérateur 96 dB

Incertitude 3

Puissance acoustique LWA 109 dB

Incertitude 3

Valeurs déterminées suivant le code d'essai de l'annexe B de la norme EN 62841-1 avec emploi des normes de base ISO 11201 et ISO 3744. Les niveaux de pression acoustique obtenus in situ dépendent:

- Des niveaux réels de la machine considérées, en prenant en compte les incertitudes déclarées.

- Du local et de l'installation de la machine. Préférez une pièce dont l'acoustique est plus feutrée. Evitez les pièces vide à grande résonance. Placez-vous auprès d'une fenêtre le cas échéant.

- Des outils montés, des pièces travaillées, des réglages choisis,...

Information :

- La ou les valeurs totales déclarées de vibration et la ou les valeurs déclarées d'émission sonore ont été mesurées conformément à une méthode d'essai normalisée et peuvent être utilisées pour comparer des outils ;

- La ou les valeurs totales déclarées de vibration et la ou les valeurs déclarées d'émission sonore peuvent aussi être utilisées dans une évaluation préliminaire de l'exposition.

Mise en garde :

- L'émission de vibration et l'émission sonore pendant l'utilisation de l'outil électrique peuvent être différentes des valeurs déclarées selon les façons d'utiliser l'outil, en particulier le type de pièce à usiner; et

- Il est nécessaire d'identifier les mesures de sécurité destinées à protéger l'opérateur qui sont basées sur une estimation de l'exposition dans les conditions réelles d'utilisation (en prenant en compte toutes les parties du cycle de manœuvres, telles que les moments où l'outil est hors tension et où il fonctionne à vide, en plus du temps d'actionnement de la manette)

| | | |
|--|--|---|
| | Porter des lunettes de sécurité : | X |
| | Draag een veiligheidsbril : | |
| | Llevar puestas gafas protectoras : | |
| | Portare de gli occhiali di sicurezza : | |
| | Utilizar óculos de segurança : | |
| | Wear protective eyewear : | |

| | | |
|--------------------|--|---|
| | Porter un masque anti-poussière: | X |
| | Draag een stofmasker : | |
| | Llevar puesta una careta de protección contra el polvo : | |
| | Indossare una mascherina anti-polvere : | |
| | Utilizar uma máscara anti-poeira : | |
| Wear a dust mask : | | |

| | | |
|------------------------------------|--|---|
| | Porter une protection auditive: | X |
| | Draag gehoorbeschermers: | |
| | Llevar puesta una protección auditiva: | |
| | Portare una protezione uditiva: | |
| Utilizar uma protecção auditiva: | | |
| Wear hearing protective equipment: | | |

| | | |
|---------------|---------------------|---|
| | Porter des gants : | X |
| | Draag handschoenen: | |
| | Usar guantes | |
| | Indossare i guanti: | |
| | Usar luvas: | |
| Wear gloves : | | |

| | | |
|---|---|---|
| | Risque de sectionnement des doigts ou de la main: | X |
| | Snijden risico van de vinger of hand: | |
| | Recyclebaar, onder voorbehoud van het sorteren: | |
| | Seccionamiento riesgo del dedo o de la mano: | |
| | Risco Seccionamento do dedo ou a mão: | |
| Sezionamento rischio del dito o della mano: | | |

| | | |
|---|----------------------------|---|
|  | Soumis à recyclage : | × |
| | Niet wegwerpen : | |
| | Sottoposti a riciclaggio : | |
| | Sujeitos à reciclagem : | |
| | Sottoposti a riciclaggio : | |
| Subjected to recycling : | | |

FR-Recyclage des déchets:

Les outils, accessoires et leur emballages doivent suivre une voie de recyclage adaptée. Conformément aux directives Européenne 2012/19/UE et 2006/66/CE, les composants d'un produit doivent être séparés, collectés, recyclés ou éliminés en conformité avec les réglementations environnementales en vigueur. Les appareils, batteries, piles, huiles, emballages devront être déposés dans les systèmes d'élimination des déchets spéciaux tels que déchetteries. Renseignez vous auprès de votre commune pour connaître l'organisme le plus proche à même de retraiter ou de collecter ces déchets.

NL-afval recycling:

Gereedschap, accessoires en verpakkingen moeten volgen een pad geschikt is voor recycling. Volgens de Europese richtlijnen 2012/19/UE en 2006/66/CE, de componenten van een product moet worden gescheiden, verzameld, gerecycleerd of verwijderd in overeenstemming met de milieuvorschriften. Apparaten, batterijen, olie, moet de verpakking worden gedeponereerd in de afvalverwerking afval, zoals stortplaatsen. Neem contact op met uw gemeente naar de dichtstbijzijnde agentschap kunnen herhalen of het verzamelen van deze afvalstoffen te vinden.

ES-Reciclado de los residuos:

Las herramientas, los accesorios y los envases tienen que seguir la vía de reciclaje adecuada. En virtud de las directivas europeas 2012/19/UE y 2006/66/CE, los componentes de un producto deben separarse, recogerse, reciclarse o eliminarse de acuerdo con las reglamentaciones medioambientales vigentes. Los aparatos, baterías, pilas, aceites, envases deberán llevarse a los centros de eliminación de residuos especiales tales como los ecoparques. Pedir información al municipio par conocer el centro más cercano apto para reciclar o recoger dichos residuos.

PT-Reciclagem do lixo:

As ferramentas, acessórios e suas embalagens devem seguir um canal de reciclagem adaptado. Conformemente às diretivas europeias 2012/19/UE e 2006/66/CE, os componentes de um produto devem ser separados, recolhidos, reciclados ou eliminados de acordo com as regulamentações ambientais em vigor. Os aparelhos, baterias, pilhas, óleos e embalagens deverão ser depositados nos sistemas de eliminação de detritos especiais, tais como unidades de triagem de detritos. Informar-se junto ao seu concelho municipal para conhecer o órgão mais próximo habilitado a evacuar ou recolher estes detritos.

IT-Riciclaggio dei rifiuti:

Gli apparecchi, i loro accessori ed imballaggi devono essere sottoposti ad un processo di riciclaggio appropriato. In conformità con le direttive europee 2012/19/UE e 2006/66/CE, i componenti di un prodotto devono essere separati, raccolti, riciclati o smaltiti in conformità con le normative ambientali in vigore. Gli apparecchi, le batterie, le pile, gli oli, gli imballaggi dovranno essere conferiti nei sistemi di smaltimento dei rifiuti speciali come le isole ecologiche. Informarsi presso il proprio comune per sapere qual è l'ente più vicino in grado di fare il trattamento o la raccolta differenziata di questi rifiuti

EN-Waste recycling:

The tools, accessories and their packaging must use an appropriate recycling channel. In compliance with European Directives 2012/19/UE and 2006/66/CE, a product's components must be separated, collected, recycled or eliminated in accordance with the environmental regulations in force. The appliance, batteries, oils and packaging must be deposited in the special waste elimination systems such as the waste collection centres. Ask your commune for information on the nearest organisation in a position to reprocess or collect this waste

| | | |
|---|---|---|
|  | Recyclable, soumis au tri sélectif: | × |
| | Recyclable, subject to recycling: | |
| | Recyclebaar, onder voorbehoud van het sorteren: | |
| | Reciclable, sin perjuicio de la clasificación: | |
| | Reciclável, sujeito a triagem: | |
| Riciclabile, soggetto a cernita: | | |

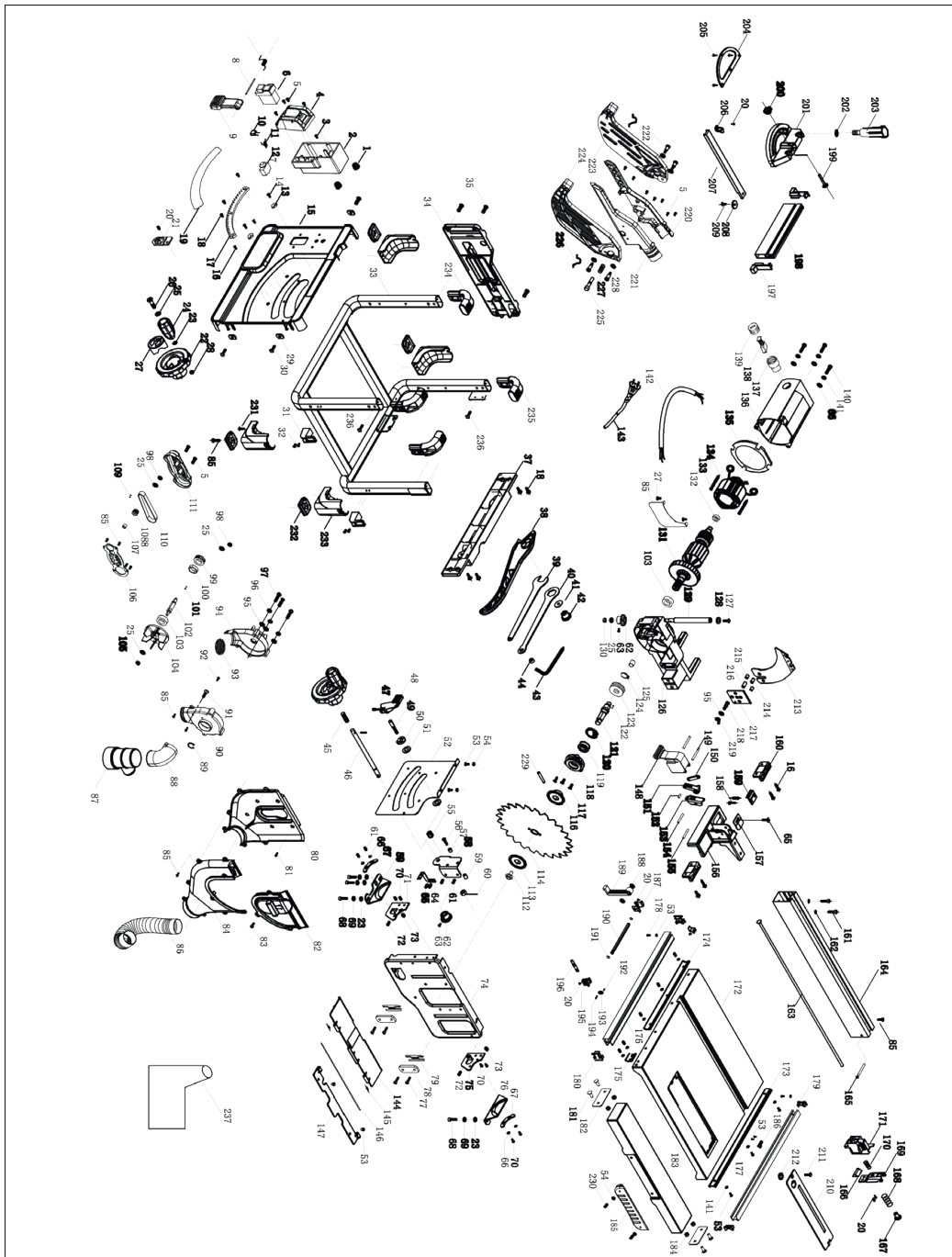

• Guide parallèle traversant à double fixations sans clé, à blocage rapide
 • Parallel guide through double keyless fixing, with quick fastening
 • Joints de protections sur carter de lame
 • Side protection on blade guard

• Plus de précision de coupe
 • More cutting precision

• Plus de sécurité
 • More safety

Machine compacte
 Compact machine

EnergySaw-185ASP



PEUGEOT

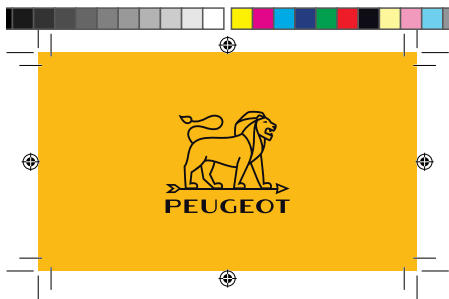
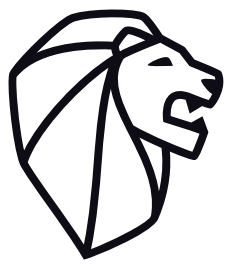
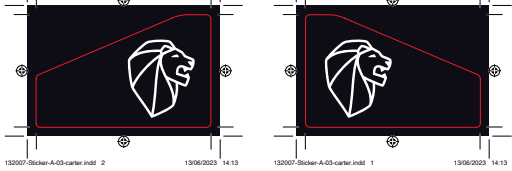

ASP System
 By PEUGEOT

Aspiration intégrée
 Dust cyclone inside

Jusqu'à / Up to **94%**
 de poussières récupérées
 of dust recovered

Système d'aspiration des poussières avec sac de récupération des poussières intégré (14 Litres)
 Dust extraction system with integrated dust extraction bag (14 Liters)

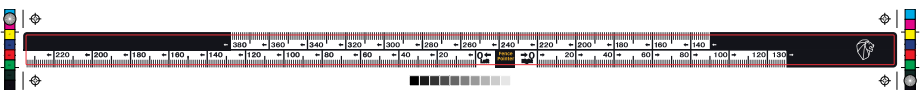

PEUGEOT
 132007 EnergySaw-185ASP

2200 W (54-30%) 230V-50Hz 6 183 mm 400 mm 41,3 mm 4300 mm¹ 42 mm 30 mm 460 x 445 mm
 25 kg

IP20

Peugeot Outillage 102 Avenue des Forges - 37100 St-Pierre-des-Forges - FRANCE





**DECLARATION CE DE CONFORMITE
DECLARACION DE CONFORMIDAD
DICHIARAZIONE DI CONFORMITA**

**VERKLARING VAN OVEREENSTEMMING
DECLARAÇÃO DE CONFORMIDADE
DECLARATION OF CE CONFORMITY**

Le soussigné,
Ondergetekende,
El suscrito,
O abaixo assinado,
Il sottoscritto,
The undersigned,

PEUGEOT OUTILLAGE

192, Avenue Yves Farge - 37700 St. Pierre-des-Corps - FRANCE
Tél. : 02 36 16 71 46 - Fax : 02 36 16 71 40

Déclare par la présente que,
Verklaart hiermede dat,
Declaro por la presente que,
Declara pela presente que,
Dichiare che,
Declares that,

CODE

PEUGEOT / 132007 / EnergySaw-185ASP / JF71801V

Scie de table / Table saw / Sierra de mesa / Serra da tabela / Segas da banco / Tafelzaag

Est conforme et satisfait aux normes CE:
In overeenstemming is met en Voldoet aan EG richtlijnen:
Cumple con la directivas de la CE:
Respeita e está em conformidade com as normas CE:
È conforme alle direttive CEE:
Complies with the EEC standards:



Machine : 2006/42/EC 2014/30/EU 2011/65/EU 2015/863/EU
Machine :
Máquina:
Máquina:
Macchina:
Machine :

EN62841-1:2015
EN62841-3-1:2014+A11:2017
AfPS GS 2014 :01 PAK
EN55014-1:2017/A11:2020
EN55014-2:2015
ENIEC61000-3-2:2019
ENIEC61000-3-11:2019
ENIEC55014-1:2021
ENIEC55014-2:2021
ENIEC61000-3-2:2019+A1:2021
EN61000-3-3:2013+A1:2019+A2:2021

SIGMA

Présidente de PEUGEOT OUTILLAGE
Représentée par son Président :
Christophe HUREL
14/06/2023
Fait à St. Pierre-des-Corps

Personne autorisée à
constituer le dossier technique :
Christophe HUREL

5 ANS 10 ANS

GARANTIE / RÉPARABILITÉ



BON DE GARANTIE

1 - Objet de la garantie :
La garantie porte exclusivement sur les vices de fabrication ou les vices de matières.
Elle nous oblige à l'échange ou à la réparation des pièces reconnues hors d'usage.

2 - Durée de la garantie :
La garantie est de 60 mois à dater de la livraison du matériel à l'utilisateur (facture ou ticket de caisse à fournir).
Les échanges ou réparations faites au titre de la garantie ne peuvent avoir pour effet de prolonger celle-ci.
Les frais de port ALLER sont à la charge de l'utilisateur.

3 - Réserves :
La garantie ne s'applique en aucun cas aux réparations effectuées en dehors de nos réparateurs agréés.
En aucun cas, durant la période de garantie, le matériel ne devra être démonté.

GARANTIEKAART

1 - Doel van de garantie:
De garantie heeft uitsluitend betrekking op fabricagefouten of gebreken in materialen.
Het dwingt ons om uit te wisselen of reparatie van erkende onbruikbare onderdelen.

2 - Duur van de garantie:
De garantie bedraagt 60 maanden vanaf de levering van apparatuur voor de gebruiker (factuur of kassabon te verstrekken).
De uitwisseling of reparaties onder garantie niet te verlengen.
GO verzendkosten zijn voor rekening van de gebruiker.

3 - Reserves:
De garantie geldt niet in alle reparaties die buiten onze goedgekeurd reparateurs.
In ieder geval gedurende de garantie, moet het materiaal worden verwijderd.

TARJETA DE GARANTÍA

1 - Objeto de la garantía:
La garantía sólo se referirá a los defectos de fabricación o defectos en los materiales.
Nos obliga a cambiar o reparación de las piezas fuera de servicio reconocido.

2 - Duración de la garantía:
La garantía es de 60 meses a partir de la entrega de equipos para el usuario (factura o recibo que se den).
Los intercambios o reparaciones bajo garantía no tendrá que prolongarse.
GO gastos de envío correrán a cargo del usuario.

3 - Reservas:
La garantía no se aplica en todas las reparaciones realizadas fuera de nuestros talleres de reparación autorizadas.
En cualquier caso, durante el período de garantía, el material debe ser removido.

CARTÃO DE GARANTIA

1 - Finalidade da garantia:
A garantia só relacionar com defeitos de fabricação ou defeitos em materiais.
Ela nos obriga a troca ou reparo de peças inservíveis reconhecidos.

2 - Duração da Garantia:
A garantia é de 60 meses a partir da entrega de equipamentos para o usuário (fatura ou recibo a ser fornecido). Trocas ou reparos sob a garantia não terá que prorrogá-la.
GO portes serão custeadas pelo usuário.

3 - Reservas:
A garantia não se aplica a quaisquer reparos feitos fora das nossas oficinas aprovadas.
Em qualquer caso, durante o período de garantia, o material deve ser removido.

GARANZIA

1 - Oggetto della garanzia:
La garanzia si riferisce esclusivamente alla difetti di fabbricazione o difetti nei materiali.
Ci costringe a scambio o la riparazione di parti inutilizzabili riconosciuti.

2 - Durata della garanzia:
La garanzia è di 60 mesi dalla consegna delle attrezzature per l'utente (fattura o ricevuta da fornire).
Scambi o riparazioni in garanzia non sarà necessario prolungarla.
GO spese di spedizione sono a carico dell'utente.

3 - Riserve:
La garanzia non si applica in tutte le riparazioni effettuate al di fuori dei nostri riparatori autorizzati.
In ogni caso, durante il periodo di garanzia, il materiale deve essere rimosso.

WARRANTY

1 - Scope of the warranty :
The warranty shall only apply to manufacturing defects or material defects.
We are obliged to exchange or repair parts that are identified as being unusable

2 - Lifetime warranty :
The warranty shall be valid for 60 months from the delivery date of the equipment to the user (invoice or bill receipt must be provided).
Exchanges or repairs carried out under the warranty shall not extend the original warranty period.
The user shall be responsible for original shipping charges.

3 - Reservations :
The warranty shall not under any circumstances cover repairs carried out by a non-authorized repairer.
The equipment should not be dismantled under any circumstances during the warranty period.

| Date d'achat | Référence machine | Cachet du distributeur |
|-------------------|--------------------------|------------------------|
| Datum van aankoop | Machine referentie | Dealer stempel |
| Fecha de compra | Referencia de la máquina | Comerciante de sellos |
| Data da compra | Referência de máquina | Selo Revendedor |
| Data di acquisto | Riferimento macchina | Timbro del rivenditore |
| Purchase date | Machine code | Distributor's stamp |
| | | |

SERVICE APRÈS VENTE - AFTER SALE SERVICE

PEUGEOT OUTILLAGE - 192, Avenue Yves Farge - 37700 St. Pierre-des-Corps - FRANCE - Tél. : 02 36 16 71 46 - Fax : 02 36 16 71 40



PEUGEOT OUTILLAGE

Une société du groupe **SIGMA**

192, Avenue Yves Farge
37700 St. Pierre-des-Corps
FRANCE

peugeot-outillage.com

