

FAR one[®] TOOLS

- FR** Scie à chantourner (Notice originale)
- EN** Scroll saw (Original manual translation)
- DE** Deku pier säge (Übersetzung aus dem Original-Anleitung)
- ES** Sega da traforo (Traducción del manual de instrucciones originale)
- IT** Sierra de marqueteria (Traduzione dell'avvertenza originale)
- PT** Sega de rodear (Tradução do livro de instruções original)
- NL** Figurzaag (Vertaling van de originele instructies)
- EL** Πλασιωτό πριόνι (Μετάφραση από τις πρωτότυπες οδηγίες)
- PL** Pila do wyrzynania (Tłumaczenie z oryginalnej instrukcji)
- FI** Konelehtisaha (Käännös alkuperäisestä ohjeet)
- SV** lövsåg (Översättning från originalinstruktioner)
- BU** Трион за профили (Превод на оригиналната инструкция)
- DA** Kontursav (Oversættelse fra oprindelige brugsanvisning)
- RO** Ferăstrău de traforaj (Traducere din instrucțiunile originale)
- RU** Лобзиковая пила (Перевод с оригинальной инструкции)
- TU** Oyma testeresi (Orijinal talimatlar çeviri)
- CS** Vykružovací pila (Překlad z originálního návodu)
- SK** Vyrézacia píla (Preklad z originálneho návodu)
- HE** תיורקמ תאורהמ סוגרת) רצ רוטמ
- AR** قىلصألا تاميلعتلا نم قمجرتلا طرخ راشنم
- HU** Lombfűrész (Fordítás az eredeti utasítások)
- SL** Žaga rezljača (Prevod iz izvornih navodil)
- ET** Ringsaag (Tõlge originaal juhiseid)
- LV** Pjūklas išpjaustymui pagal šablonu (Tulkojumā no instrukcijas oriģinālvalodā)
- LT** Finierzgūtis (Vertimas iš originalių instrukcijas)
- LT** Izrezan pila (Prijevod prema originalne upute)

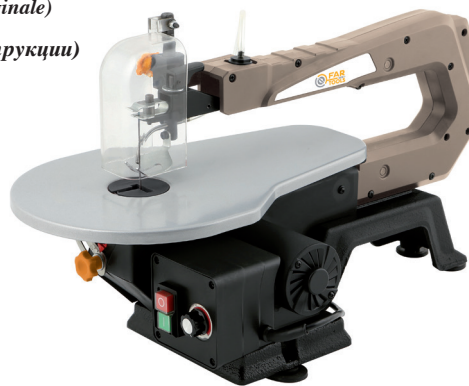

S 16C
Professional Machine



© FAR GROUP EUROPE

113254-3-H-20220622

fartools.com



FIG. A

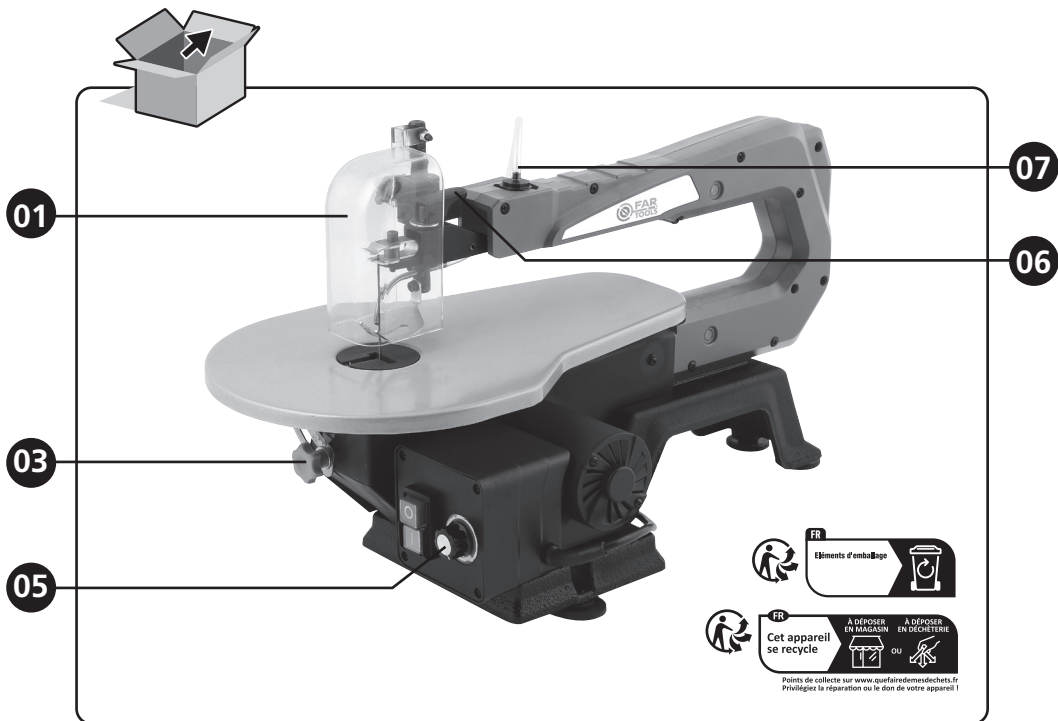

FIG. B

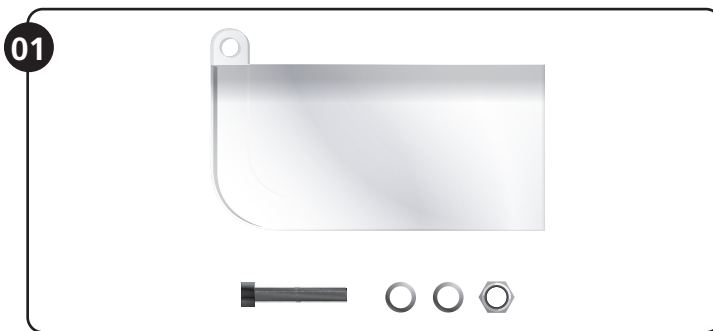
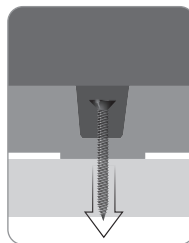
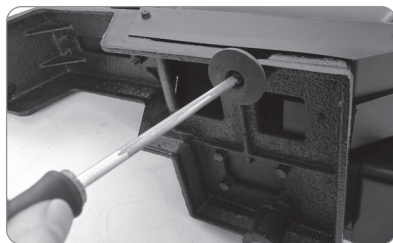
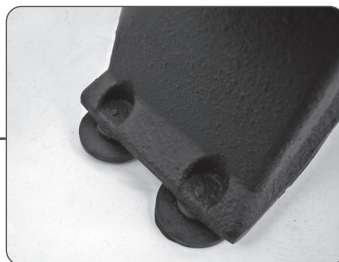
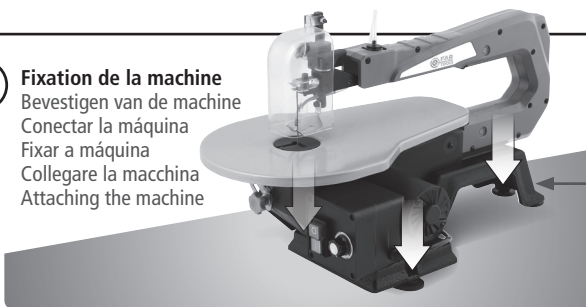



FIG. B

01

Fixation de la machine
Bevestigen van de machine
Conectar la máquina
Fixar a máquina
Collegare la macchina
Attaching the machine



02

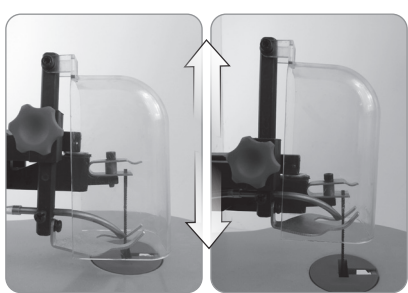
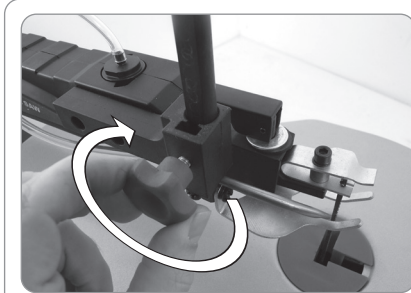
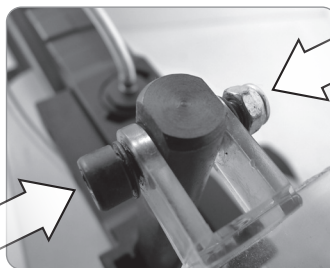



FIG. C

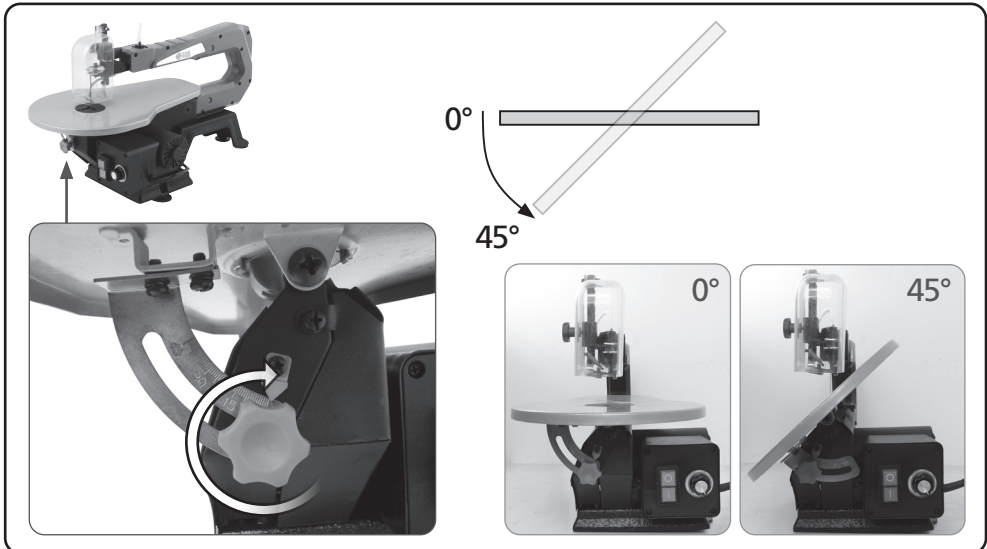
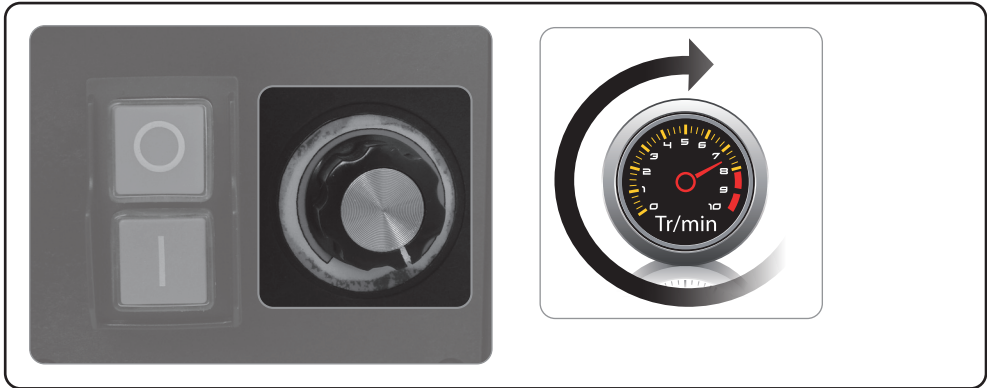
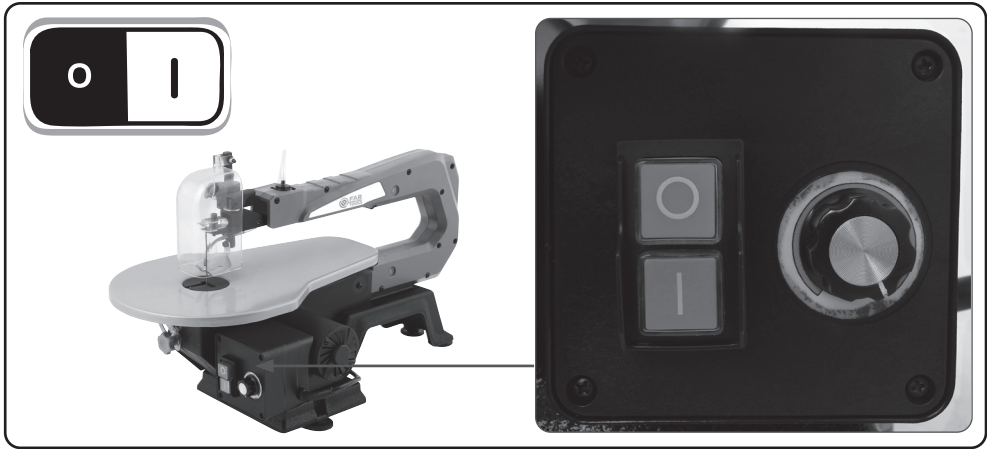
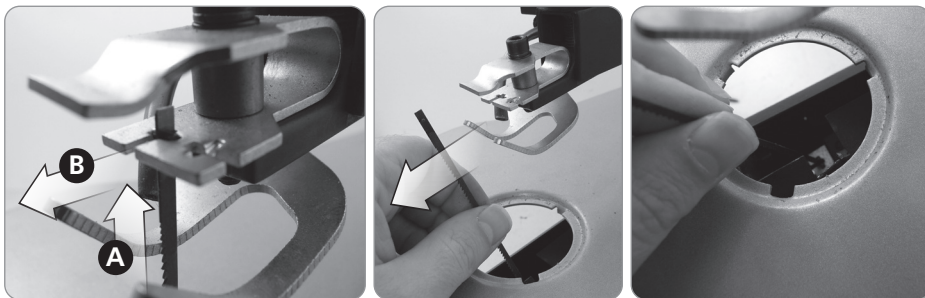
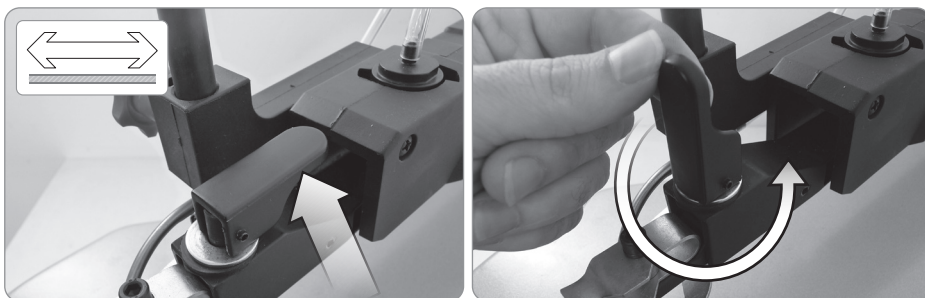
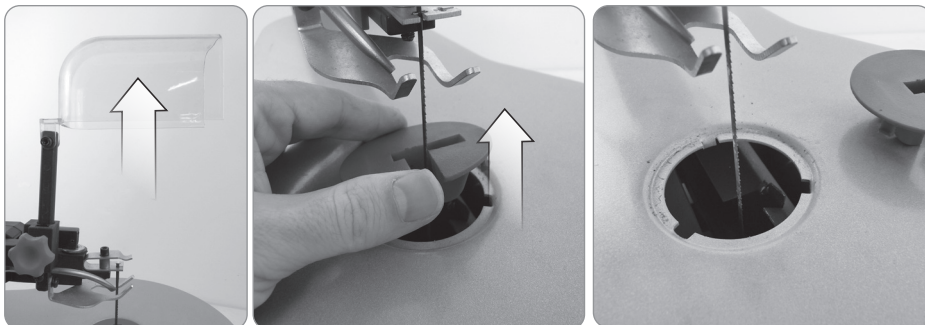



FIG. C



Ref : 113803
Ref : 113810
Ref : 113813 + 113780

0°

90°

ou or





- Cet appareil n'est pas prévu pour être utilisé par des personnes (y compris les enfants) dont les capacités physiques, sensorielles ou mentales sont réduites, ou des personnes dénuées d'expérience ou de connaissance, sauf si elles ont pu bénéficier, par l'intermédiaire d'une personne responsable de leur sécurité, d'une surveillance ou d'instructions préalables concernant l'utilisation de l'appareil.

- Il convient de surveiller les enfants pour s'assurer qu'ils ne jouent pas avec l'appareil.

- Dit product is niet bedoeld voor gebruik door personen (inclusief kinderen) met een lichamelijke, zintuiglijke of geestelijke vermogens, of gebrek aan ervaring of kennis, tenzij ze zijn gegeven door door een persoon die verantwoordelijk is voor hun veiligheid, toezicht of instructies over het gebruik van het apparaat.

- Het moet toezicht houden op kinderen om ervoor te zorgen dat zij niet met het apparaat spelen.

- This product is not intended for use by persons (including children) with physical, sensory or mental capabilities, or lack of experience or knowledge, unless they have been given by through a person responsible for their safety, supervision or instruction concerning use of the device.

- It should supervise children to ensure they do not play with the device.

- Este producto no está diseñado para ser utilizado por personas (incluidos niños) con capacidades físicas, sensoriales o mentales, o la falta de experiencia o conocimiento, a menos que hayan sido dadas por través de una persona responsable de su seguridad, supervisión o instrucciones relativas al uso del dispositivo.

- Se debe supervisar a los niños para asegurarse de que no jueguen con el dispositivo.

- Este produto não é destinado ao uso por pessoas (incluindo crianças) com capacidades físicas, sensoriais ou mentais, ou falta de experiência ou conhecimento, a menos que tenham sido dadas por através de uma pessoa responsável pela sua segurança, supervisão ou instruções relativas à utilização do dispositivo.

- Deve vigiar as crianças para garantir que eles não brincam com o dispositivo.

- Attention ! Rester à distance des pièces en mouvement.
- Caution ! To remain remote parts moving.
- Beachtung ! An Distanz der Stücke in Bewegung bleiben.
- ¡ Atención ! Seguir siendo partes a distancia en movimiento.
- Attenzione ! Restare a distanza parti in movimento.
- Atenção ! Permanecer a distância peças em movimento.



- Ne doit être utilisée que par une seule personne !
- Must be used only by only one person !
- Darf nur von nur einer Person benutzt werden !
- ¡ Debe utilizarse que por una única persona !
- Deve essere utilizzata soltanto da una sola persona !
- Deve ser utilizado apenas por só uma pessoa !





	<p>Tension et fréquence assignée: Nominal frequency and power: Nennspannung und Nennfrequenz : Tensión y frecuencia fijada: Tensione e frequenza assegnata: Tensão e frequência fixa: Aangewezen spanning en frequentie: ΟΝΟΜΑΣΤΙΚΗ ΤΑΣΗ ΚΑΙ ΣΥΧΝΟΤΗΤΑ: Napięcie i częstotliwość przydzielona: Jännite ja määrittäty taajuus: Angiven spänning och frekvens: Anført spænding og frekvens: Tensiune și frecvență de lucru:</p>	<p>Заданное напряжение и частота: Tahsis gerilimi ve frekansı: Stanovené napětí a frekvence: Stanovené napätie a frekvencia: Merkespenning og merkefrekvens: الغليظية والذبذبة الجيرمجة. Névleges feszültség és frekvencia: Napetost in določena frekvenca: Консумирано напрежение и честота : Määratud pinge ja sagedus Nustatytá (tampa) ir dažnis Noteiktais spriegums un frekvence. Napon i nazivna frekvencija:</p>	230 V ~ 50 Hz
---	---	--	---------------

	<p>Puissance assignée: Nominal power: Nennleistung: Potencia fijada: Potenza assegnata: Potência assinada: ΟΝΟΜΑΣΤΙΚΗ ΙΣΧΥΣ: Prędkość na biegu jalowym: Teho: Angiven effekt: Anført styrke: Putere de lucru:</p>	<p>Заданная мощность: Tahsis edilen güc: Stanovený příkon: Predpísaný výkon: Merkeeffekt: القدرة الجيرمجة. Névleges teljesítmény : Določena jakost: Консумирана мощност: Määratud võimsus. Nustatytá galia Noteiktā jauda Nazivna snaga:</p>	120 W (S2)
---	---	--	------------

SERVICE TEMPORAIRE 10 min

Fonctionnement à charge constante pendant un temps déterminé inférieur au temps de l'équilibre thermique suivi d'un repos suffisant pour rétablir l'égalité de température entre le moteur et l'air de refroidissement.

OBSERVATION: ce service peut permettre une puissance utile supérieure à la puissance nominale.

	<p>Vitesse à vide: No-load speed: Leerlaufdrehzahl: Velocidad vacía: Velocità a vuoto: Velocidade no vácuo: Leerlaufdrehzahl: ΤΑΧΥΤΗΤΑ ΑΔΡΑΝΕΙΑΣ: Prędkość bez obciążenia: Tyhjäkäyntinopeus Tomgångshastighet: Hastighed i ubelastet tilstand: Viteza în gol:</p>	<p>Скорость вращения на холостом ходу: Boşalma hızı: Rychlost naprázdno: Rýchlosť pri chode naprázdno: Tomgangshastighet: السريعة على الفراغ. Üres sebesség: Prosti tek: Скорост на празни обороти: Kiirus tühikäigul Tuščio prietaiso greitis Tukšgaitas ātrums Brzina praznog hoda:</p>	400-1600 min ⁻¹
---	--	---	----------------------------

	<p>Lire les instructions avant usage : Read the instructions before use : Vor Einsatz des Geräts Anweisung lesen : Léase las instrucciones antes de usar : Leggere le istruzioni prima dell'uso : Ler as instruções antes da utilização : Lees voor het gebruik de instructies : ΔΙΑΒΑΣΤΕ ΤΙΣ ΟΔΗΓΙΕΣ ΠΡΙΝ ΑΠΟ ΤΗ ΧΡΗΣΗ: Zapoznać się instrukcją przed użyciem : Lue ohjeet ennen käyttöä : Läs anvisningarna före användning : læs instruktionerne før brug Înainte de utilizare, cititi instructiunile :</p>	<p>Внимательно прочитайте следующие инструкции : Kullanmadan talimatları okuyunuz : Pozorně si přečtete následující pokyny : Pred použitím si prečítajte pokyny : Les bruksanvisningen før bruk: اقرأ التعلیمات قبل الاستخدام. használat előtt olvassuk el az utasítást : Pred uporabo preberite ustrezna navodila Прочетете указанията за употреба : Enne kasutamist lugege instruksiooni Prieš naudojimą perskaityti instrukciją izlasīt instrukcijas pirms lietošanas Pročitati upute prije uporabe:</p>	X
---	--	---	---





	Porter des lunettes de sécurité : Wear protective eyewear : Schutzbrille tragen : Llevar puestas gafas protectoras : Portare de gli occhiali di sicurezza : Utilizar óculos de segurança : Draag een veiligheidsbril : ΦΟΡΑΤΕ ΠΡΟΣΤΑΤΕΥΤΙΚΑ ΓΥΑΛΙΑ: Zakładać okulary ochronne : Käytä suojalaseja : Använd skyddsglasögon : Der skal benyttes sikkerhedsbriller : Purtati ochelari de protectie :	Наденьте защитные очки : Güvenlik gözlükleri takın : Používejte bezpečnostní brýle : Noste ochranné okuliare : Bruk vernebriller: حمل نظارات وقاية. Viseljen védőszemüveget : Nositi zaščitna očala : Да се използват защитни очила : Kandke kaitseprille Nešioti apsauginius akinius Valkät aizsargbrilles Nositi zaštitne naočale:	×
---	---	--	---

	Porter un masque anti-poussière : Wear a dust mask : Staubschutzmaske tragen : Llevar puesta una careta de protección contra el polvo : Indossare una mascherina anti-polvere : Utilizar uma máscara anti-poeira : Draag een stofmasker : ΦΟΡΕΣΤΕ ΜΑΣΚΑ ΓΙΑ ΤΗ ΣΚΟΝΗ: Zakładać maskę przeciwpylową Käytä pölysuojust : Bär mask mot damm : Der skal benyttes beskyttelsesmaske mod støv: Purtati mască anti-praf :	Наденьте респиратор : Toza karşı maske takın : Používejte masku proti prachu : Noste ochrannú masku proti prachu : Bruk en støvmaske: لبس قناع مضاد للغباب. Viseljen porvédő maszkot Nositi zaščitno masko proti prahu: Да се използва защитна маска : Kandke tolmumaski. Dėvėti respiratorių Valkät aizsarg masku pret putekļiem Nositi masku za zaštitu od prašine:	×
---	--	---	---

	Porter une protection auditive : Wear hearing protective equipment: Gehörschutz tragen: Llevar puesta una protección auditiva: Portare una protezione uditiva: Utilizar uma protecção auditiva: Draag gehoorbeschermers: ΦΟΡΑΤΕ ΠΡΟΣΤΑΣΙΑ ΑΚΟΗΣ: Zakładać słuchawki ochronne Käytä kuulosuojaimia: Bär hörselskydd: Der skal benyttes høreværn: Purtati căști de protectie auz:	наденьте средства звуковой защиты: İşitsel koruma aleti takın: Používejte ochranu sluchu: Noste ochranné sluchadlá: Bruk hørselsvern: لبس خوذة خضض الخرجي Viseljen fúlvédőt Nositi zašito ušes: Да се използва слухови защитни средства: Kandke kõrvakaitset Nešioti apsaugą nuo triukšmo Valkät dzirdes aizsarglīdzekli Nositi štitnike protiv buke:	×
---	---	---	---

	Porter des gants : Use rubber gloves : Schutzhandschuhe tragen : Llevar guantes de protección : Indossare i guanti di protezione : Utilizar luvas de protecção : Draag veiligheidshandschoenen : ΦΟΡΩΝΤΑΣ ΓΑΝΤΙΑ: Używać rękawic ochronnych : Käytä suojakäsineitä : Använd skyddshandskar : Der skal benyttes handsker : Purtati mănuși :	Наденьте перчатки : Eldiven takın : Noste rukavice : Noste rukavice : Bruk hansker: لبس قفازات. Viseljen kesztyű t Nositi rokavice: а се използват предпазни ръкавици : Kandke kindaid Mūvēti pirštines Valkät cimds Nositi zaštitne rukavice:	×
---	--	--	---





 L_{pA}	Niveau de pression acoustique :	Уровень акустического давления. :	90,1 dB (A)
	Acoustic pressure level :	Akustik basınç seviyesi :	
	Schalldruckpegel :	Hladina akustického tlaku :	
	Nível de presión acústica :	Hladina akustického tlaku :	
	Livello di pressione acustica :	Lydtrykknivå:	
	Nível de pressão acústica :	مستوى الضغط الصوتي.	
	Niveau akoestische druk :	A hangnyomás szintje :	
	ΣΤΑΘΜΗ ΗΧΗΤΙΚΗΣ ΠΙΕΣΗΣ:	Nivo akustičnega pritiska:	
	Poziom mocy akustycznej :	Равнище на акустично налягане :	
	Käytä kuulosuojaimia:	Helirõhu nivoo	
Ljudtrycksnivå :	Akustinio spaudimo lygis		
Lydtryk :	Akustiskā spiediena līmenis		
Nível presiune acustică :	Razina zvučnog tlaka:		

 L_{WA}	Niveau de puissance acoustique :	уровень мощности звука :	103,1 dB (A)
	Acoustic power level :	Akustik basınç seviyesi :	
	Schalleistungspegel :	Hladina zvukového výkonu:	
	Nível de potencia acústica :	Hladina zvukového výkonu:	
	Livello di potenza acustica:	Lydeffektivnivå:	
	Nível de potência acústica:	مستوى الضخجيج.	
	Niveau akoestisch vermogen :	a hangnyomás szintje :	
	ΕΠΙΠΕΔΟ ΙΣΧΥΟΣ ΉΧΟΥ:	Nivo akustične jakosti :	
	Poziom mocy akustycznej :	Равнище на вибрации :	
	Käytä suojalaseja :	Helivõimsuse nivoo	
Ljudstyrkenivå :	Triukšmo lygis		
Lydstyrke :	Akustiskās jaudas līmenis		
Nível putere acustică :	Razina zvučne snage:		

NIVEAU SONORE D'ÉMISSION :

A VIDE

Pression acoustique LpA poste opérateur
Incertitude

90,1 dB
3

Puissance acoustique LWA
Incertitude

103,1 dB
3

Valeurs déterminées suivant le code d'essai de l'annexe B de la norme EN 61029-1 avec emploi des normes de base ISO 11201 et ISO 3744.

Les niveaux de pression acoustique obtenus in situ dépendent:

- Des niveaux réels de la machine considérées, en prenant en compte les incertitudes déclarées;
- Du local et de l'installation de la machine. Préférez une pièce dont l'acoustique est plus feutrée. Evitez les pièces vides à grande résonance. Placez vous auprès d'une fenêtre le cas échéant.
- Des outils montés, des pièces travaillées, des réglages choisis,...





	<p>Conformité européenne Conforms to EC standards : CE-Konformität : Cumples con las directivas CE : Conforme alle norme CE : Conforme às normas CE : Voldoet aan de EG-normen : ΕΥΡΩΠΑΪΚΗ ΣΥΜΜΟΡΦΩΣΗ Zgodność z normami CE : EU-standardien mukainen : EU-standardien mukainen : Overholder EU standarderne : Conform cu normele europene:</p>	<p>соответствие европейским стандартам: Avrupa uygunluk : evropská shoda : európska dohoda : Europeisk konformitet مطابق للجواصفات الأوروبية: evropska ustreznost : európai megfeleléség : Съответствие с европейските норми : Euroopa Liidu vastavusmärk Europinių normų atitikima Atbilstība Eiropas standartiem Euroopska sukladnost</p>	×
---	---	---	---

	<p>Soumis à recyclage Subjected to recycling Sujeto a reciclaje Sottoposti a riciclaggio Sujeitos à reciclagem Não deite no lixo : Niet wegwerpen : ΥΠΟΚΕΙΤΑΙ ΣΕ ΑΝΑΚΥΚΛΩΣΗ Nie wyrzucac : Älä heitä pois luontoon : Batteriet får inte kastas : Bortkast det ikke: Nu le auncati :</p>	<p>Подлежит переработке Atmayıniz : Nevyhazujte je do bežného odpadu : Neodhadzovat : Gjenvinningspliktig قلنا ترمدها هلذا فسي القمامة. ne mečite1 Ne odvržite ga/jih vstran : Taaskasutusse kuuluv Ärge visake seda minema : Nemetykrite : Nemest : Podvrngnuto recikliranju</p>	×
---	---	---	---

Recyclage des déchets :

Les outils, accessoires et leur emballages doivent suivre une voie de recyclage adaptée. Conformément aux directives Européenne 2012/19/UE et 2006/66/CE, les composants d'un produit doivent être séparés, collectés, recyclés ou éliminés en conformité avec les réglementations environnementales en vigueur. Les appareils, batteries, piles, huiles, emballages devront être déposés dans les systèmes d'élimination des déchets spéciaux tels que déchetteries. Renseignez-vous auprès de votre commune pour connaître l'organisme le plus proche à même de retraiter ou de collecter ces déchets.

	<p>Recyclable, soumis au tri sélectif Recyclable, subject to recycling Recyclingfähige, unterliegen Recycling Reciclables, sujetos a reciclaje Riciclabili, soggetti a riciclaggio Recicláveis, sujeito à reciclagem Recycleerbare, onderworpen aan recycling ΑΝΑΚΥΚΛΩΣΙΜΟ, ΥΠΟΚΕΙΤΑΙ ΣΕ ΕΠΙΛΕΚΤΙΚΗ ΔΙΑΛΟΓΗ Opakowanie nadaje się do recyklingu podlegają recyklingu Kierrätettävien pakkausten kohteena kierrätys Återvinningsbara förpackningar omfattas återvinning Рециклираци се опаковки подлежат на рециклиране Genanvendelig underlagt genbrug</p>	<p>Reciclabile sub rezerva reciclare Повторно упаковка подлежит вторичной переработке Geri dönüŝüm Geri dönüŝtürülebilir ambalaj konusu Recyklovateľné podléhajáci recykláci Recyklovateľné podliehajúce recyklácii Resirkulerbar, med forbehold om selektiv sortering ريودنلا خا زال يرضت ريودنلا خا زال قبازلأ فيل يندلا و قوب يندلا Újrahasznosítható csomagolás alá újrahasznosítás Reciklirati predmet recikliranje Pakendite suhtes ringlussevõtu Pärstrådåjams iepakojums otrreizējai pārstrādei Perdirbamų taikomos perdirbimo Može se reciklirati, podložno selektivnom sortiranju</p>	×
---	--	---	---





	Danger :	Опасно :	X
	Danger :	Tehlike :	
	Gefahr :	Nebezpečí :	
	Peligro :	Nebezpečnost :	
	Pericolo :	Fare:	
	Perigo :	خطر.	
	Gevaar :	Veszély :	
	ΚΙΝΔΥΝΟΣ:	Nevarnost:	
	Niebezpieczeństwo :	Опасночост :	
	Vaara :	Oht	
	Fara :	Pavojus	
	Fare :	Bīstamība	
Pericol :	Opasnost:		

	Dimensions table :	Размеры стола :	413 x 253 mm
	Dimensions of table :	Tablo boyutu :	
	Tischabmessungen :	Rozměr stolu :	
	Dimensiones mesa :	Rozměry dosky :	
	Dimensioni tabella :	מידת שולחן	
	Dimensões da mesa :	أبعاد الطاولة	
	Afmetingen tafel :	Az asztal mérete:	
	Διαστάσει τραπεζιού :	Dimenzije ventilatorja:	
	Wymiary stolu :	Размери на плота :	
	Mittapöytä :	Ketta suurus :	
	Bordets storlek :	Stovo matmenes :	
	Bordets mål :	Galda izmēri :	
Dimensiuni masă :	Tablica dimenzija:		

		405 x 50 mm
--	--	-------------

	Poids :	Вес :	10,4 kg
	Weight :	Ağırlık :	
	Gewicht :	Hmotnost :	
	Peso :	Hmotnosť :	
	Peso :	Vekt:	
	Peso :	الوزن.	
	Gewicht :	Súly :	
	ΒΑΡΟΣ :	Teža :	
	Masa :	Тегло :	
	Paino :	Raskus	
	Vikt :	Svoris	
	Vægt :	Svars	
Greutate :	Težina		

	Classe d'isolement :	Класс изоляции :1	X
	Insulation class : 1	Yalıtım derecesi :1	
	Isolierklasse: 1	Třída izolace :1	
	Aislamiento clase :1	Izolačný systém 1	
	Isolamento classe :1	Isolasjonsklasse: 1	
	Isolamento classe :1	فئة العزل 1.	
	Isolatie Klasse : 1	Szigetelési osztály :1	
	ΚΑΤΗΓΟΡΙΑ ΜΟΝΩΣΗΣ: 1	Razred izolacije :1	
	Izolacja Klazy :1	Инструмент Клас:1	
	Eristysluokka :1	Isolatsiooniklass 1	
	Isolering Klass :1	Izolācijas rūšis 1	
	Isoleringssklasse :1	Izolācijas klase 1	
Clasă izolatie : 1	Izolacija klasa: 1		





S 16C

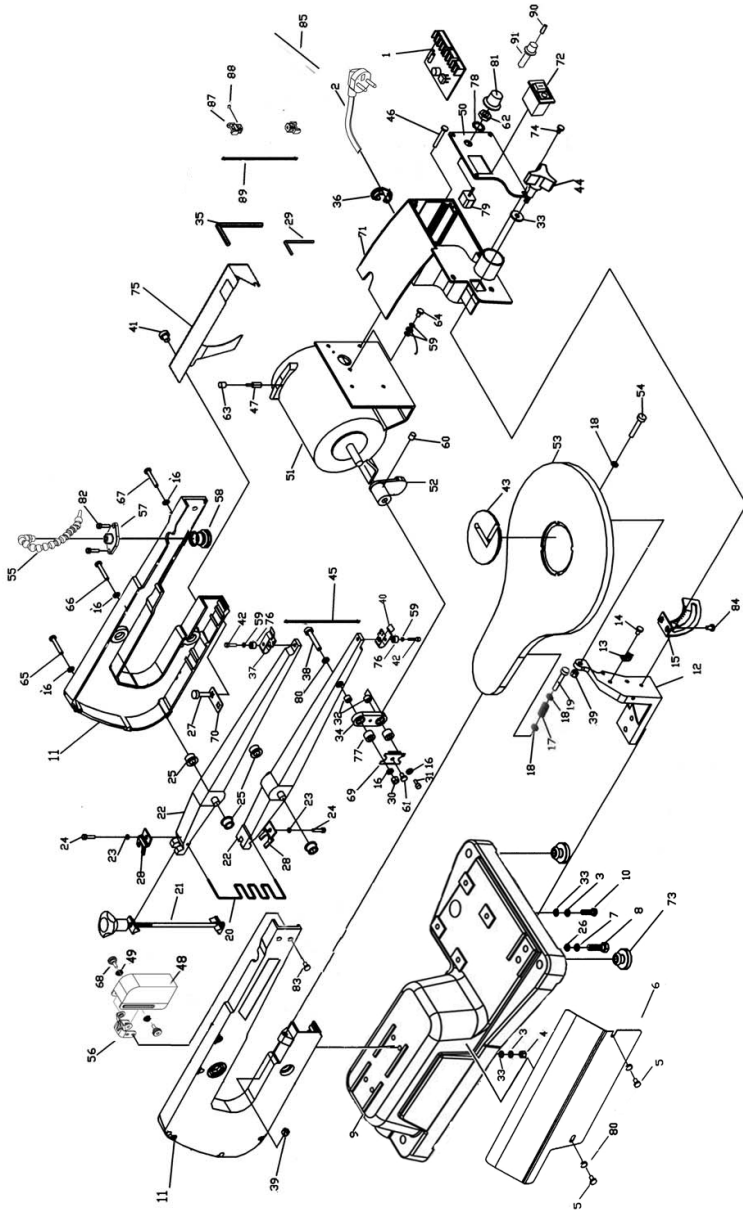

DECLARATION DE CONFORMITE
VERKLARING VAN OVEREENSTEMMING
DECLARACION DE CONFORMIDAD
DICHIARAZIONE DI CONFORMITA
KONFORMITÄSERKLÄRUNG
DECLARATION CONFORMITY
DECLARAÇÃO DE CONFORMIDADE
DEKLARACJA ZGODNOSCI Z NORMAMI
OM ÖVERENSSTÄMMELSE
VAATIMUSTENMUKAISUUSVAKUUTUS
ÖVERENSSTEMMELSESERKLÄRING
ΔΗΛΩΣΗ ΣΥΜΜΟΡΦΩΣΗΣ

DECLARATIE DE CONFORMITATE
VYHLÁSENIE ZHODY
Декларация соответствия
SAMSVARERKLÆRING
Uyguluk beyanı
الاصدريج بالخطابق
PROHLÁŠENÍ SHODY
EGYZÉSI NYILATKOZAT
Декларация за съответствие с нормите
IZJAVA O SKLADNOSTI
DEKLARACIJA
ATTITIKTES DEKLARACIJA
KINNITUS
IZJAVA O SUKLADNOSTI

Le soussigné,
Ondergetekende,
Der Unterteichner,
O abaixo assinado,
Undertecknad,
Долуподписаният
Undertegnede
Subseminatul,
Я, нижеподписавшийся,
Imzalayan,
Niže podepsány,
Toliau pasirašęs

Personne autorisée à constituer
le dossier technique :

Ronan GUILLIOT



FAR GROUP EUROPE
192, Avenue Yves Farge
37700 St. Pierre-des-Corps
FRANCE

El suscrito,
Il sottoscritto,
The undersigned,
Ninei podpisany
Allékirjoittanut,
Ο ΚΑΤΩΘΙ ΥΠΟΓΡΑΜΜΕΝΟΣ,
Nizšie podpisany
Undertegnede,
الاصدريج بالخطابق
Alulírott,
Podpisani,
Apakšā parakstījies
allakirjutanu
Dolje potpisani,

Declara por la presente que,
Dichiare che,
Declares that,
Oświadczam niniejszym, że
Ilmoittetaan täten että,
ΔΙΑ ΤΟΥ ΠΑΡΟΝΤΟΣ ΔΗΛΩΝΕΙ 'ΟΤΙ,
tymto vyhlasuje, že
Erklærer herved at,
يصرح استنادا على ذلك
kijelentem, hogy a készülék Izjavlja da,
Pareiskia, kad,
Ar šo apliecinā, ka,
Kinnitab, et
izjavljuje u ovom dokumentu da je

Déclare par la présente que,
Verklaart hiermede dat,
Erklärt hiermit daß,
Declara pela presente que,
Förklarar härmed att
Заявляя с настоящото
erklærer hermed, at
Declar prin prezenta că,
настоящим подтверждаю, что
Mevcut belgeyle beyan ediliyor ki,
tımto prohlasuje, že,
Pareiskia, kad,

Scie à chantourner / Scroll Saw / Deku pier sāge / Segs da Traforo / Sierra de Marqueteria / Segs de Rodear / Figurzaag / ΠΑΛΙΣΙΩΤΟ ΠΡΙΟΝΙ / Pila do wyrzynania /
Konelehtisaha / lövsåg / Трион за профили / Kontursav / Ferāstrāu de traforaj / Лобзиковая пила / Oyma testeresi / Vykružovací pila / Vyřezávací pilka / בר דומם /
خارخ راشينم / Lombfűrész / Zaga rezljača / Ringsaag / Pjūkklas išpjaustymui pagal šablona / Finierzägits

code

FARTOOLS ONE / 113254 / S 16C / CSJ400A

Est conforme et satisfait aux directives et normes CE,
In overeenstemming is met en Voldoet aan EG richtlijnen,
Den folgenden EU-Bestimmungen entspricht,
Respeita e está em conformidade com as normas CE,
Överensstämmer med och uppfyller EG-standarder,
Съответства и отговаря европейските норми
Er i overensstemmelse med og overholder EU standarderne
Este conform și satisface normele CE
полностью соответствует и удовлетворяет
требованиям стандартов ЕС
CE şartlara uygundur,
odpovídá normám ES.
Atitinka ir atitinka EB direktyvas ir standartus,

Cumple con la directivas de la CE,
E conforme alle direttive CEE,
Complies with the EEC directives and standards,
Odpowiada normom UE,
Täyttää EU-vaatimukset,
ΣΥΜΜΟΡΦΩΝΕΤΑΙ ΚΑΙ ΙΚΑΝΟΠΟΙΕΙ ΤΙΣ ΟΔΗΓΙΕΣ ΚΑΙ ΤΑ ΠΡΟΤΥΠΑ CE,
zodpovedá normám ES.
Samsvarer med og tilfredsstiller CE-direktiver og standarder,
بان الجواز يطابق و يلبى مع ما يورد من مواجعة الدول الأوروبية
kielegiti a CE szabványok előírásait.
Je v skladu z in izpolnjuje norme Evropske skupnosti.
Atbilst un atbilst EK direktivas un standartus,
Vastab ja vastab EU direktiividele ja standardeitele,
Sukladan i ispunjava direktive i standarder CE,

Attestation de type (EC type) N° AM 50501270 0001

Rapport (report) N° 15081314 005

TUV Rheinland LGA Product GmbH
Tillystrasse 2 - 90431 Nürnberg - GERMANY
Enregistré sous (registred under) N° 0197

2006/42/EC 2014/30/EU 2011/65/EU 2015/863/EU

EN 61000-3-3:2013+A1+A2
EN IEC 61000-3-2:2019+A1
EN IEC 55014-2:2021
EN 62841-1:2015
EN ISO 12100:2010
EN IEC 55014-1:2021

Ronan GUILLIOT,
Directeur général
22/06/2022
Fait à St. Pierre-des-Corps

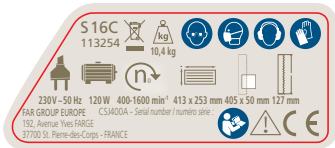

GARANTIE - WARRANTY



FR. GARANTIE

Cet outil est garanti contractuellement contre tout vice de construction et de matière, à compter de la date de vente à l'utilisateur et sur simple présentation du ticket de caisse. La garantie consiste à remplacer les parties défectueuses. Cette garantie n'est pas applicable en cas d'exploitation non conforme aux normes de l'appareil, ni en cas de dommages causés par des interventions non autorisées ou par négligence de la part de l'acheteur. La garantie ne s'applique pas sur les dommages causés par une défaillance de l'outil.

DE. GARANTIE

Die Garantiezeit für dieses Gerät in Bezug auf Konstruktions- und Materialfehler beträgt lt. Vertrag bei Vorlage des Kassensbons. Die Garantieleistung besteht im Ersatz schadhafter Teile. Die Garantie erlischt bei einem Einsatz des Geräts, der nicht normentsprechend ist, bei Schäden, die auf unsachgemäße Eingriffe zurückzuführen sind bzw. bei Nachlässigkeit seitens des Käufers. Die Garantie erstreckt sich nicht auf Schäden, die auf Fehlfunktionen des Geräts zurückzuführen sind.

IT. GARANZIA

Quest' attrezzo è garantito per contratto contro qualsiasi difetto di costruzione e di materia, a partire dalla data di vendita all' utente e su semplice presentazione dello scontrino. La garanzia consiste nel sostituire le parti difettose. Questa garanzia non è applicabile in caso di sfruttamento non conforme alle norme dell' apparecchio, né in caso di danni causati da interventi non autorizzati o da negligenza da parte dell' acquirente. La garanzia non si applica ai danni causati da un' avaria dell' attrezzo.

EN. GARANTIE

This tool is guaranteed, in writing, against any defect in manufacture or parts from the date of sale, upon simple presentation of the sales slip. The guarantee is limited to the replacement of faulty parts. This guarantee is not applicable in the event of usage which is not conform with the intended usage of the apparatus, nor in the event of damage caused by unauthorised servicing or negligence on behalf of the purchaser. This guarantee does not apply to any damage caused by

the failure of this tool.

ES. GARANTIA

Esta herramienta se garantiza contractualmente contra todo defecto de construcción y materia, a partir de la fecha de venta a l' usuario y sobre simple presentación del recibo de caja. La garantía consiste en sustituir a las partes defectuosas. Esta garantía no es aplicable en caso de explotación no conforme a las normas del aparato, ni en caso de daños causados por intervenciones no autorizadas o por negligencia por parte del comprador. La garantía no se aplica sobre los daños causados por un fallo del herramienta.

NL. GARANTIE

Dit gereedschap heeft een garantie tegen constructiefouten en materiaaldefecten, die geldig is vanaf de aankoopdatum door de gebruiker, op vertoning van de kassabon. De garantie betreft de vervanging van de defecte onderdelen. Deze garantie is niet van toepassing indien het apparaat niet volgens de normen gebruikt is, noch in geval van schade veroorzaakt door oneigenlijk gebruik of nalatigheid van de koper. De garantie is niet van toepassing op schade voortvloeiend uit een defect van het gereedschap.

PT. GARANTIA

Esta ferramenta tem uma garantia contratual contra qualquer defeito de construção e de material, a partir da data de venda ao utilizador e sobre simples apresentação do talão da caixa. A garantia consiste em substituir as partes defeituosas. Esta garantia não é aplicável no caso de exploração não conforme as normas do aparelho, nem em caso de danos causados pelas intervenções não autorizadas ou por negligência da parte do comprador. A garantia não se aplica para os danos causados por uma falha da ferramenta.

EL. ΕΓΓΥΗΣΗ

ΑΥΤΟ ΤΟ ΕΡΓΑΛΕΙΟ ΕΙΝΑΙ ΣΥΜΒΑΤΙΚΑ ΕΓΓΥΗΜΕΝΟ ΓΙΑ ΟΤΟΙΟΔΗΠΟΤΕ ΚΑΤΑΣΚΕΥΑΣΤΙΚΟ ΚΑΙ ΥΛΙΚΟ ΕΛΑΤΤΩΜΑ, ΑΠΟ ΤΗΝ ΗΜΕΡΟΜΗΝΙΑ ΠΩΛΗΣΗΣ ΣΤΟΝ ΧΡΗΣΤΗ ΚΑΙ ΜΕ ΤΗΝ ΕΠΙΔΕΙΞΗ ΤΗΣ ΑΠΟΔΕΙΞΗΣ ΠΩΛΗΣΗΣ. Η ΕΓΓΥΗΣΗ ΣΥΝΙΣΤΑΤΑΙ ΣΤΗΝ ΑΝΤΙΚΑΤΑΣΤΑΣΗ ΤΩΝ ΕΛΑΤΤΩΜΑΤΙΚΩΝ ΕΞΑΡΤΗΜΑΤΩΝ. ΑΥΤΗ Η ΕΓΓΥΗΣΗ ΔΕΝ ΙΣΧΥΕΙ ΣΕ ΠΕΡΙΠΤΩΣΗ ΛΕΙΤΟΥΡΓΙΑΣ ΠΟΥ ΔΕΝ ΣΥΜΜΟΡΦΩΝΕΤΑΙ ΜΕ ΤΑ ΠΡΟΤΥΠΑ ΤΗΣ ΣΥΣΚΕΥΗΣ, ΟΥΤΕ ΣΕ ΠΕΡΙΠΤΩΣΗ ΖΗΜΙΑΣ ΠΟΥ ΠΡΟΚΑΛΕΙΤΑΙ ΑΠΟ ΜΗ ΕΞΟΥΣΙΟΔΟΤΗΜΕΝΕΣ ΕΠΕΜΒΑΣΕΙΣ Ή ΑΜΕΛΕΙΑ ΕΚ ΜΕΡΟΥΣ ΤΟΥ ΑΓΟΡΑΣΤΗ. Η ΕΓΓΥΗΣΗ ΔΕΝ ΙΣΧΥΕΙ ΓΙΑ ΖΗΜΙΑΣ ΠΟΥ ΠΡΟΚΑΛΟΥΝΤΑΙ ΑΠΟ ΑΣΤΟΧΙΑ ΕΡΓΑΛΕΙΟΥ.

PL. GWARANCJA

Narz dzie jest objte gwarancją na wszelkie wady konstrukcyjne

i materiałowe, licząc od daty sprzedaży uytownikowi i po okazaniu paragonu, kasowego. Gwarancja obejmuje wymiany cz. Aci wybrakowanych. Gwarancja nie znajduje zastosowania w przypadku uytowania niezgodnego z normami urzadzenia, ani w przypadku szkod spowodowanych działaniami niedozwolonymi lub zamiebaniami ze strony nabywcy. Gwarancja nie obejmuje szkod powstałych z powodu upadku urzadzenia.

SV. GARANTI

Detta verktyg har en avtalsenlig garanti mot konstruktions och materialfel, från och med tidpunkten för användarens inköp och genom uppvisning av kassakvittot. Garantin består i att ersätta de bristfälliga delarna. Denna garanti gäller inte om användningen inte motsvarar apparatens standarder, inte heller vid skador som orsakas av ej tillatna ingrepp eller på grund av koparens vårdslöshet. Garantin gäller inte forskador som orsakats av att verktyget fungerat bristfälligt.

FI. TAKUU

Tämän laitteen takuu on voimassa sopimuksenmukaisesti kattaa kaikki rakennne- ja materiaaliiviat lukien ostopäivästä, kassakvittia vastaan. Takuu sisältää viallisten osien korvaamisen. Takuu ei korvaa ohjeiden vastaista käyttöä eikä vialtuuttamattomien henkilöiden kasittelystä tai ostayen huolimattomuudesta aiheutuneita vahinkoja. Takuu ei vastaa myöskään toimintahäiriöistä aiheutuneita vahinkoja.

BU. Гаранция

Този инструмент е под договорна гаранция срещу всякакъв дефект в изработката и използваните материали, считано от датата на продажба на потребителя и само срещу представяне на касовата бележка. Гаранционното обслужване се състои в замяна на дефектните части. Настоящата гаранция не е валидна когато апаратът се използва по начин, несъответстващ на стандарта за работа с него, както и в случай на щети, нанесени от неоторизирани лица, или вследствие на проявена небрежност от страна на потребителя. Гаранцията не покрива щети, произтекли вследствие на техническа неизправност на апарата.

DA. GARANTI

Dette værktøj er dækket af en garantikontrakt for konstruktions- og materialefejl, som gælder fra købsdatoen ved visning af kassebonen. Garantien består i at udskifte de defekte dele. Garantien dækker ikke fejl opstået som følge af anvendelse, som ikke overholder standarderne for apparatet, eller

SERVICE APRÈS VENTE - AFTER SALE SERVICE

FARGROUP EUROPE - 192, Avenue Yves Farge - 37700 St. Pierre-des-Corps - FRANCE

fargroup@fargroup.net



skader opstået ved ikke autoriserede indgreb eller sløsethed fra brugerens side. Garantien dækker ikke skader opstået, fordi værktøjet har svigtet.

RO. GARANTIE

Acest aparat este garantat din punct de vedere contractual împotriva tuturor vicijilor de construcție și de material, începând de la data vânzării lui către utilizator și la simpla prezentare a bonului de casă. Garanția constă în înlocuirea componentelor defecte. Această garanție nu se aplică în cazul exploatarei în alt mod decât cel recomandat de normele aparatului și nici în caz de stricăciuni provocate de intervenții neautorizate sau prin neglijența comparătorului. Garanția nu se aplică asupra pagubelor cauzate de o defectare a aparatului.

RU. ГАРАНТИЯ

Данное изделие обладает имеющей силу контракта гарантией, покрывающей все возможные дефекты изготовления и материала. Гарантия вступает в силу с даты продажи изделия пользователю, для этого достаточно сохранить и предъявить полученный в кассе Чек. Гарантия обязывает изготовителя заменить дефектные части изделия. В случае не соответствующего нормам использования изделия, несанкционированного демонтажа или ремонта или небрежного обращения действие гарантии прекращается. Гарантия не покрывает ущерба, возникшего в результате سوء в работе изделия.

TU. GARANTII

Bu arac, satis tarihinden itibaren, kullanıcının sağdece vezne alınırsini sunmasiya tum uretim ve malzeme hatasina karsi garantilidir. Garanti eksik olan kisimlari degistirmek icindir. Bu garanti aracin sartlarina uygun olmayan isleme durumunda, izin verilmeyen kullanimlardan kaynaklanan hasarlardan veya alicinin istegi durumunda uygulanmaz. Garanti malzemenin bir eksikliginden meydana gelen bir zararda uygulanmaz.

CS. ZÁRUKA

Pro tento nástroj platí smluvní záruka na všechny výrobní a materiálové vady od data prodeje uživateli a na základě předložení pokladničního bloku. Záruka spočívá ve výměně vadných částí. Tato záruka neplatí v případě použití přístroje, které

neodpovídá normám, ani v případě škod způsobených nepovolenými zásahy nebo nedbalostí ze strany kupujícího. Záruka se nevztahuje na škody způsobené zavádou nástroje.

SK. ZÁRUKA

Pre tento nástroj platí zmluvná záruka na všetky výrobné a materiálové chyby od dátumu predaja užívateľovi a na základe predloženia pokladničného bloku. Záruka spočíva vo výmene chybných častí. Táto záruka neplatí v prípade použitia prístroja, ktoré nezodpovedá normám, ani v prípade škod spôsobených nepovolenými zásahmi alebo nedbalosťou zo strany kupujúceho. Záruka sa nevztahuje na škody spôsobené poruchou nástroja

AR. الضمان

ق لعتي عارشاتقأطب ميذقت درجم بلع اعابيو لعنسملا بلا عيلا خيرات نم ارايعنا ،داوملا فوع بنصتلا يف بيع يا نم ايدقاعت فومضم قد علا هذه تا تاغاللال فصرت لأاحف الو زأاحلا ريباعمل فناملا ريب. مادختسلا لأاح يف قبيظلل الباق نامضلا اذه نوكي ال قأاعلا عارجالا لادبتس ياف نامضلا للخ نم ختاتلا روضلا بلع نامضلا قبطني ال يرتسملا ليق نم لامبالا لأاح يف وأ فصخرم ريب لحتت تاملعم نع فجنابر

HU. GARANCIA

Erre a szerszámra szerződéses garanciát vállalunk bármilyen gyártási és anyaghiba felmerülése esetére, a fogyasztó részre törtenet eladás napjától számítva, a penztári blokk egyszerű felmutatása elleneben. A garancia a hibás alkatrészek cseréjére terjed ki. Ez a garancia nem érvényes, ha a készüléket nem rendeltetésszerűen használták, sem illetéktelen beavatkozások, vagy a vásárló hanyagsága okozta károk esetén. A garancia nem fedezi azokat a károkat, melyeket a szerszám hibás működése okozott.

SI. GARANCIJA

To, orodje je z garancijsko pogodbo zasčitero proti vsem napakam v izdelavi in v sestavnem materialu od datuma prodaje naprej in ta velja ob predložitvi blagajniškega računa. Garancija velja za zamenjavo delov z napako. Ta garancija ne velja za uporabo orodja, ki ni v skladu z normami, predpisanimi za omenjeno orodje in za primere okvar, ki nastanejo zaradi nedovoljenih posegov na orodju ali zaradi malomarnega rokovanja kupca. Garancija ne velja za škodo, ki jo lahko povzroci okvara orodja.

ET. GARANTII

See tööriist kuulub lepingu järgi garantiiremonti arvestades alates müümise päevast ja kassatseki alusel kasutajale koigi konstruktsiooni- ja materjalivigade puhul. Garantii seisneb defektsete osade välja vahetamises. See garantii ei kehti

aparaadi normide ebatavalise eiramise puhul ega ostja poolt keelatud viisil kasutamisesest või hooletussejätmisest tulenevate kahjude korral. Garantii ei kehti seadme defektidest põhjustatud kahjude puhul

LV. GARANTĪJA

Šis prietais ir garantēts kārtīgi izstrādāts un pārbaudīts, un tā ir paredzēta lietošanai saskaņā ar norādītajiem lietošanas noteikumiem. Garantija neattiecas uz bojumiem, kas radušies nepareizi izmantojuma dēļ, vai uz bojumiem, kas radušies nepareizi izmantojuma dēļ, vai uz bojumiem, kas radušies nepareizi izmantojuma dēļ, vai uz bojumiem, kas radušies nepareizi izmantojuma dēļ.

LT. GARANTIJA

Šis darbininkas ir liguma noteikta garantija visiem defektiem, kas susistas ar konstrukciju un materialu, sakot ar pardosanas datumu, kad masinu pardod lietotajam un vienkarši uzradot kases ceku. Garantija ieklavu bojato dalu nomaimu. Si garantija nav deriga, ja aparats nav lietots saskana ar drospibas noteikumiem, ne gadijumos ja bojajumi radusies nesankcionetas. Iejauksanas gadijuma vai ari pierceja nolaidibas del. Garantija nav deriga, ja bojajumi radusies darbarnika defekta del.

HR. JAMSTVO

Ovaj alat ima ugovorno jamstvo u slucaju bilo kakvih nedostataka u konstrukciji i materijalu, od datuma prodaje korisniku uz jednostavno predocenje racuna. Jamstvo se sastoji u zamjeni neispravnih dijelova. Ovaj se jamstvo ne primjenjuje u slucaju uporabe i eksploatacije koja nije sukladna standardima uređaja, niti u slucaju stete uzrokovane neovlastenim intervencijama ili nemarom kupca. Jamstvo se ne primjenjuje na štetu uzrokovanu nekim nedostatkom alata.

SERVICE APRÈS VENTE - AFTER SALE SERVICE

FARGROUP EUROPE - 192, Avenue Yves Farge - 37700 St. Pierre-des-Corps - FRANCE

fargroup@fargroup.net



FAR GROUP EUROPE

Une société du groupe **SIGMA**

192, Avenue Yves Farge
37700 St. Pierre-des-Corps
FRANCE

fartools.com

