

Ref.003269

Vers.1

Bucher Memphis XXL

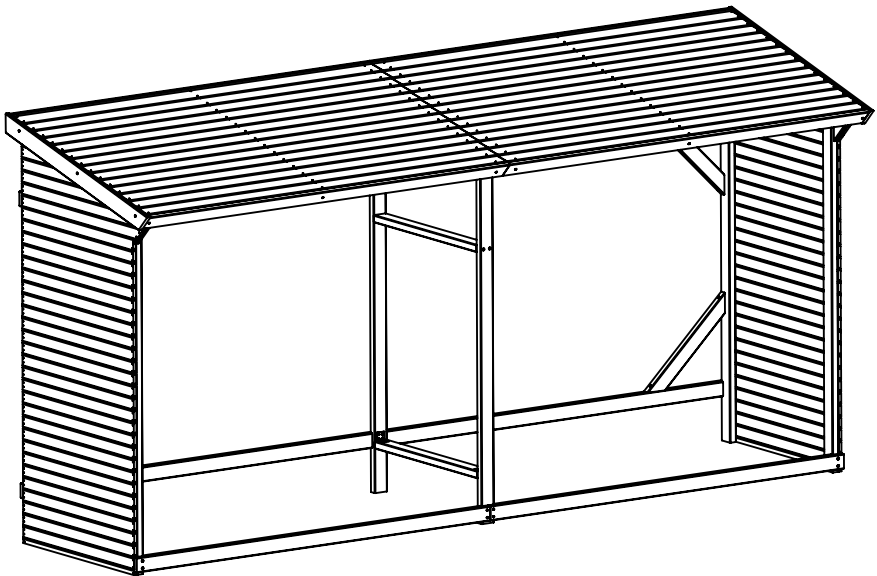

Traitement

Pour assurer la pérennité du bois en extérieur, nous traitons nos produits en autoclave. Ce procédé d'imprégnation du bois par vide et pression permet d'avoir un traitement du bois par des agents conservateurs non toxiques. Ce traitement permet au produit d'être protégé contre les insectes, les pourritures, les champignons et les termites dans les conditions d'utilisations de sa classe (III ou IV).

Entretien

Le bois est un matériau naturel vivant, dont les dimensions, aspects, masses, formes et teintes peuvent évoluer, sans modifier les propriétés ni la fonctionnalité et la qualité du produit. Le bois subit un processus de grisaillement naturel au fil du temps qui nécessite un entretien régulier.



Entretien à l'eau 1 fois/an contre les éventuelles traces de mousse.



Possibilité de raviver la couleur avec un dégriseur et d'appliquer 2 nouvelles couches de lasure aqueuse 1 fois/an sur les produits lasurés.

Retrouvez nos outils & conseils sur www.forest-style.com

English

Treatment

To ensure the sustainability of wood outdoors, we treat our product with autoclave process. This impregnation process of wood by pressure and vacuum allows a wood treatment by non-toxic preservatives. This treatment allows the product to be protected against insects, rot, fungi and termites in the conditions of its class of uses (III or IV)

Maintenance

Wood is a living natural material, the dimensions, aspects, weights, shapes and colors may change without changing the properties or functionality and quality of the product. Wood suffered a natural greyish tinge over time which requires maintenance.



Maintenance with water 1time/year against any traces of foam.



Possibility to revive the color with dégriseur and apply 2 new aqueous glaze layers 1time/year on the product.

Find our tools & tips on www.forest-style.com

Imprägnierung

Damit das Holz besser vor Witterungseinflüssen geschützt ist, behandeln wir unsere Produkte mit dem Kesseldruckimprägnier-Verfahren (KDI). Der Prozess der Imprägnierung mit Druck und Vakuum ermöglicht eine Behandlung des Holzes mit nicht-toxischen Mitteln. Dieses Verfahren schützt das Holz vor Insekten, Schimmel und Termiten. Die Intensität des Schutzes richtet sich nach der erzielten Gebrauchsklasse (III oder IV).

Pflege

Holz ist ein natürlicher und aktiver Rohstoff, dessen Abmessungen, Aussehen, Gewicht, Form und Farbton sich je nach der Holzart, aus der der Rohstoff gewonnen wurde, verändern können. Aufgrund von Oxidationsprozessen tendiert Holz zum Grauwerden. Um dies zu vermeiden, sollte das Holz regelmäßig gepflegt werden.



Jährliche Reinigung mit Wasser zur Vermeidung von möglicher Moosbildung empfehlenswert.



Es ist möglich, die ursprüngliche Farbe mit einem Entgrauer zurück zu bekommen. Tragen Sie zum verbesserten Schutz einmal jährlich 2 Schichten wasserlösliche Lasur auf.

Finden Sie unsere Tipps und Hinweise auch auf www.forest-style.com

Español

Tratamiento

Para asegurar la sostenibilidad de la madera de exterior tratamos nuestros productos con el proceso autoclave. En este proceso de impregnación de la madera a presión y vacío, la madera se trata con componentes no tóxicos. Este tratamiento protege el producto contra insectos, putrefacción, hongos y termitas en las condiciones de uso según las clases III o IV.

Mantenimiento

La madera es una materia natural viva; sus dimensiones, aspecto, peso, forma y color pueden cambiar sin modificar las propiedades o funcionalidad y calidad del producto. Sin embargo, debido a que la madera fue sometida a un tratamiento de tinte verdoso, con el tiempo requerirá un mantenimiento.



Mantenimiento con agua 1 vez/año. Evitar restos de espuma.



Se puede revitalizar el color y aplicar 2 capas de esmalte 1 vez/año.

Encontrar nuestras herramientas y consejos en www.forest-style.com

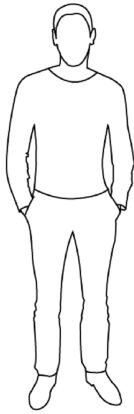
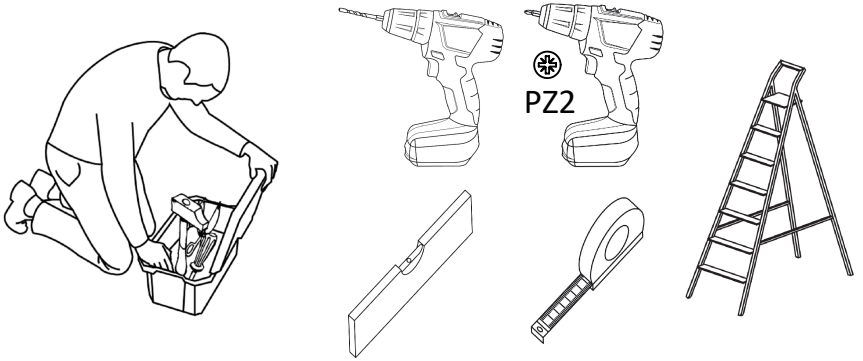

x2



03:00



www.forest-style.com

I
 \varnothing 5x70mm (x24)

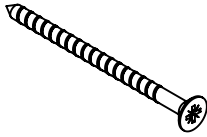

II
 \varnothing 4x50mm (x16)



III
 \varnothing 4x40mm (x24)



IV
 \varnothing 3x25mm (x16)



V
 metal angle 40x40mm (x2)

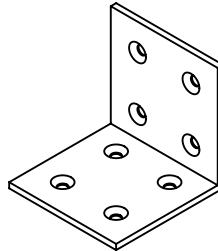

Pré-perçage recommandé / Pre-drilling recommended / Vorbohren empfohlen / Perforacion previa recomendada

\varnothing Vis / \varnothing Screw / \varnothing schraube / \varnothing Tornillo	\varnothing Percage / \varnothing Drilling / \varnothing Bohrung / \varnothing Perforacion
\varnothing 5 (I)	\varnothing 4
\varnothing 4 (II, III)	\varnothing 3

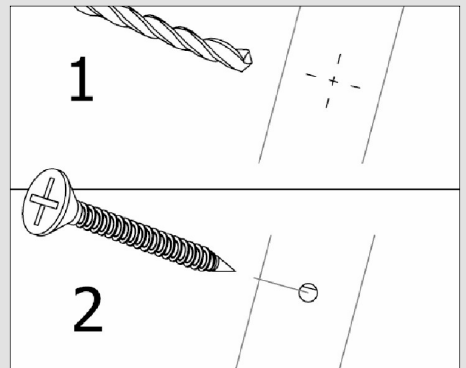

A

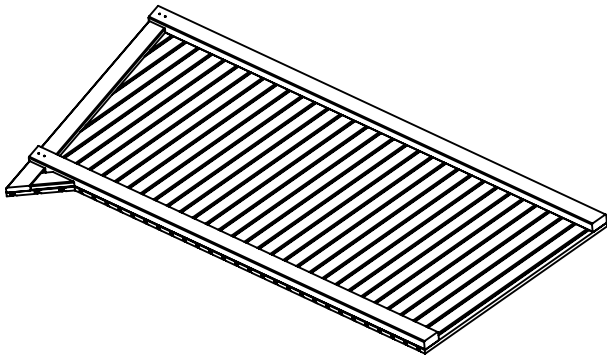

x1

B

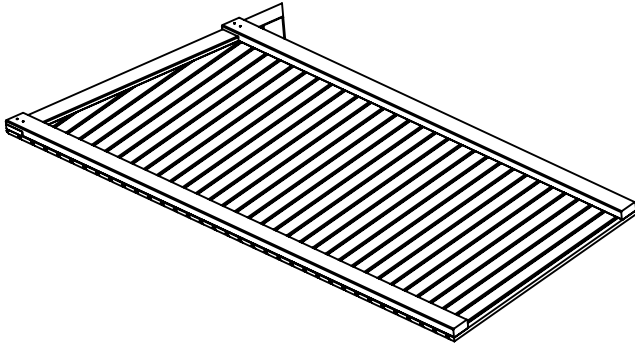

x1

C

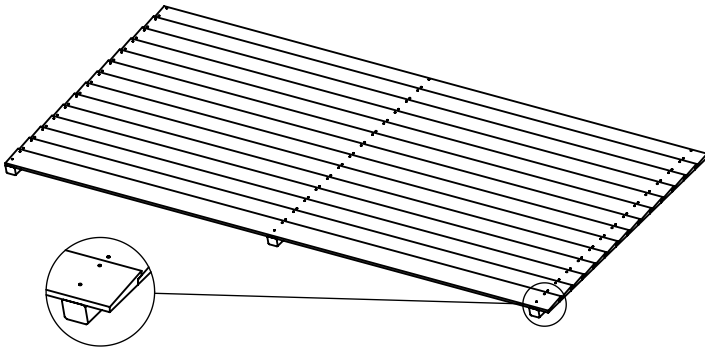

x1

D

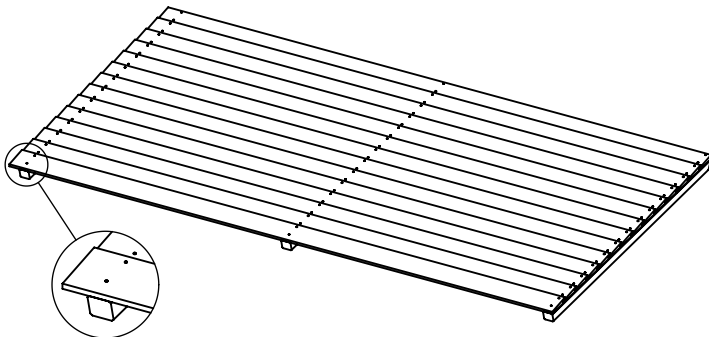

x1

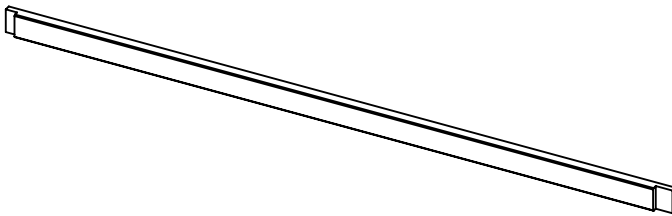
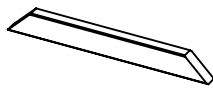
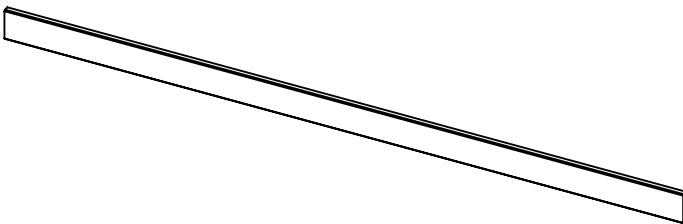
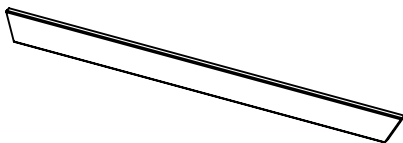
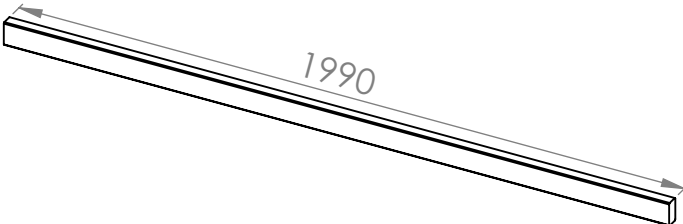
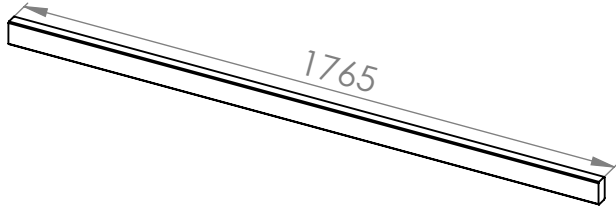
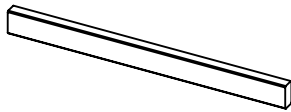
E		x6
F		x4
G		x4
H		x2
J		x1
K		x1
L		x2

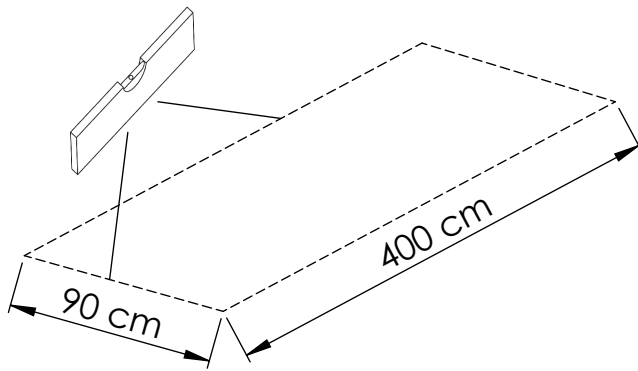

1/11

L x1
IV x8
V x2

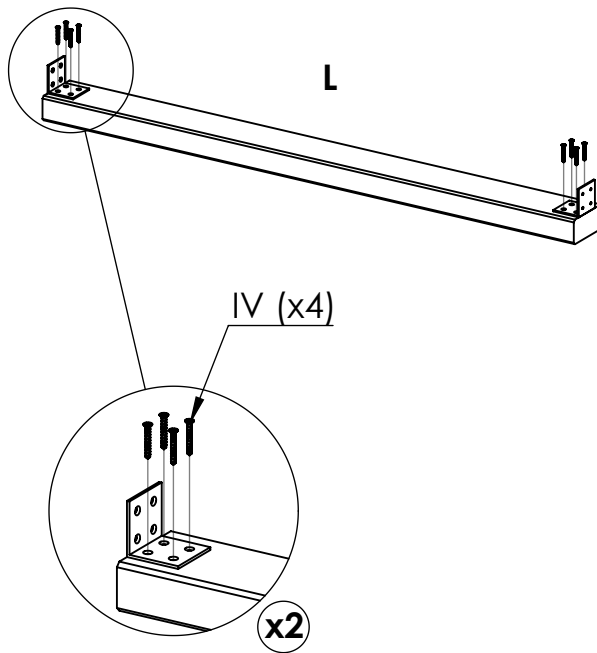

2/11

- J x1
- K x1
- L x1
- I x4
- IV x8

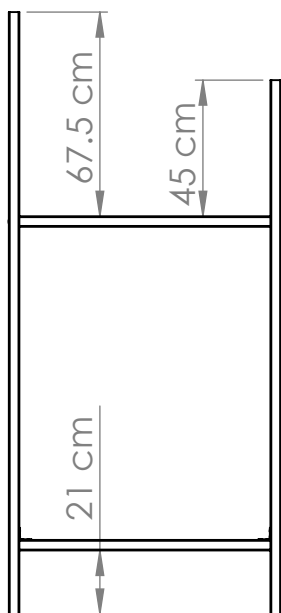
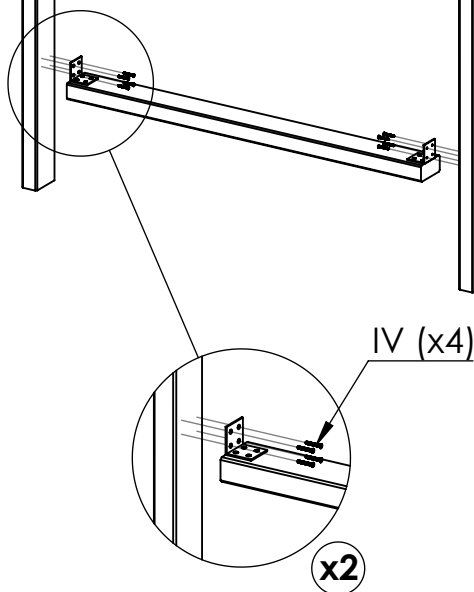
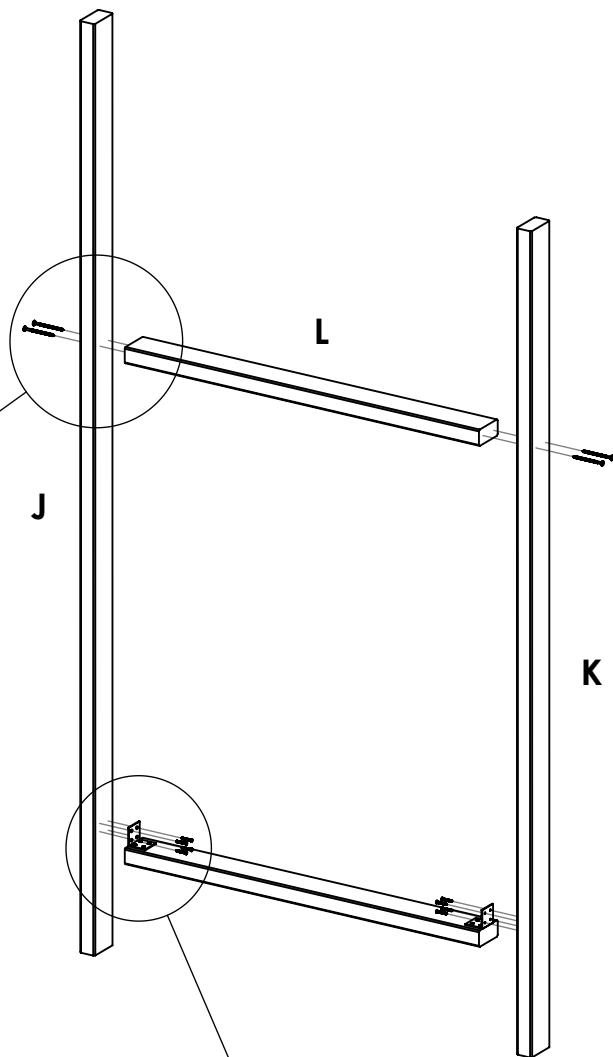
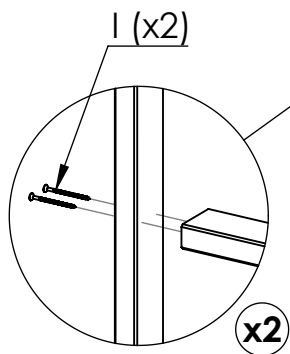

3/11

- A x1
- E x1
- I x2
- II x2

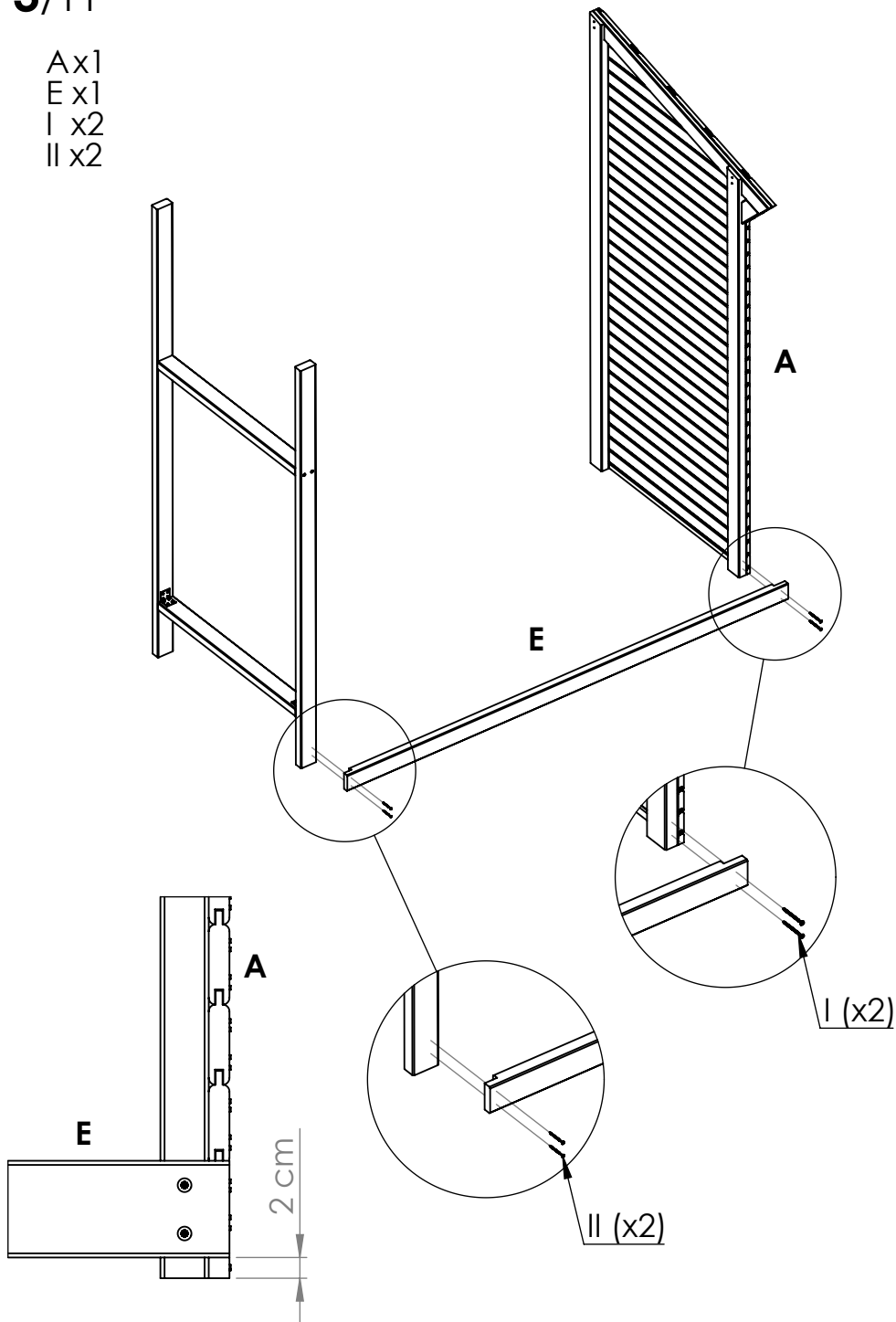

4/11

E x2
I x4
II x4

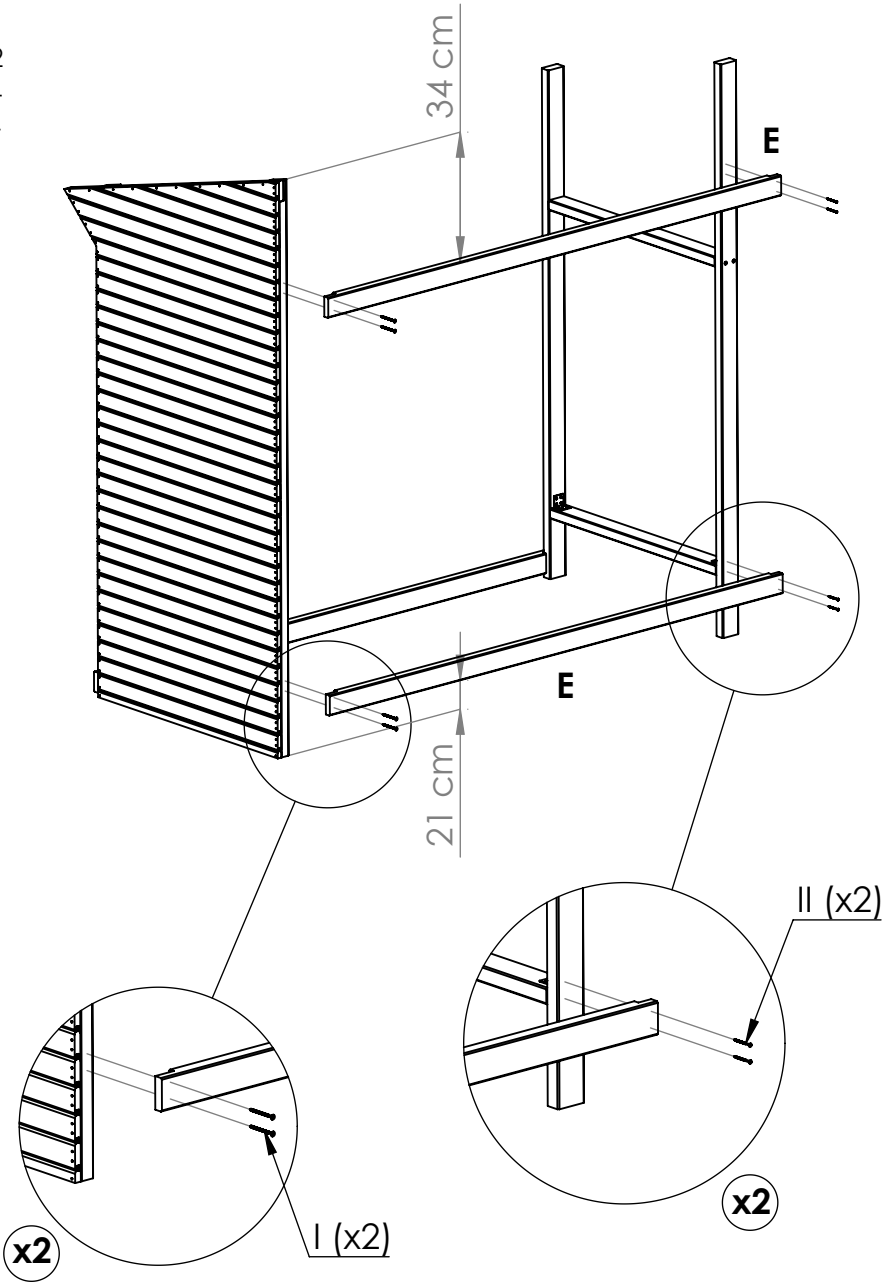

5/11

- B x1
- E x2
- I x4
- II x4

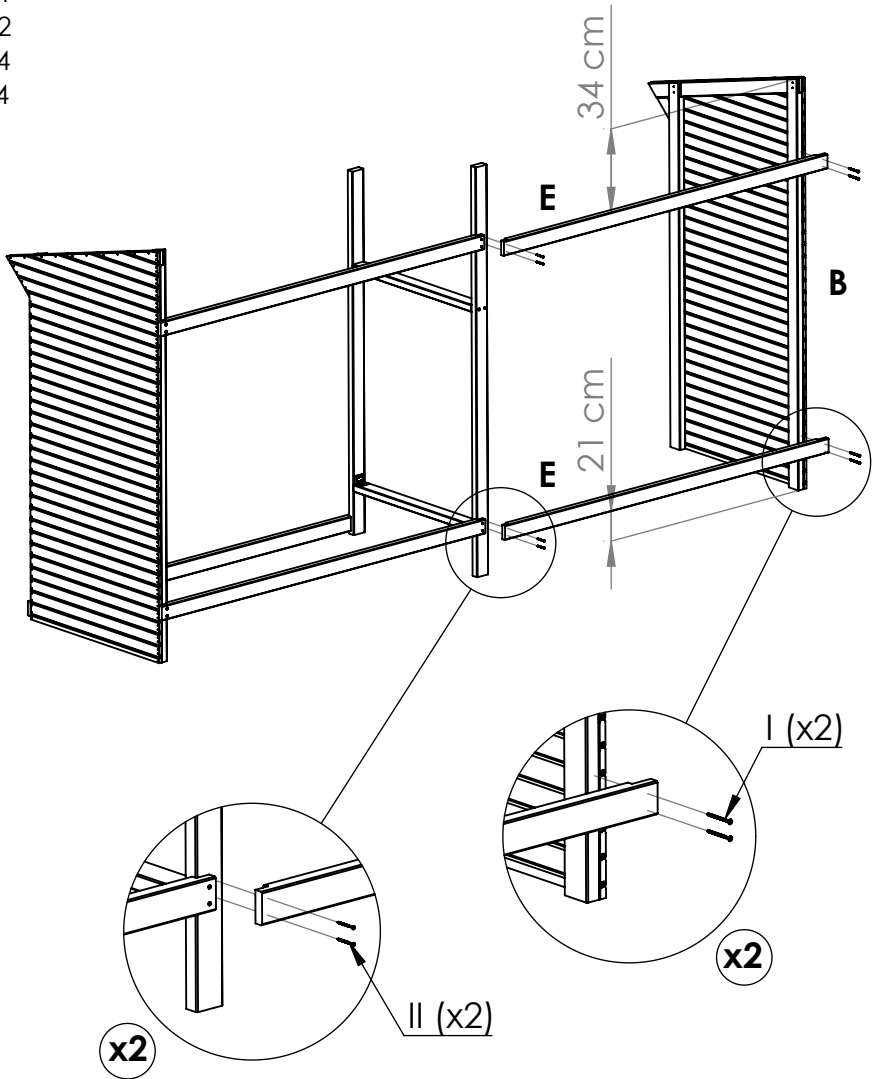

6/11

E x1

I x2

II x2

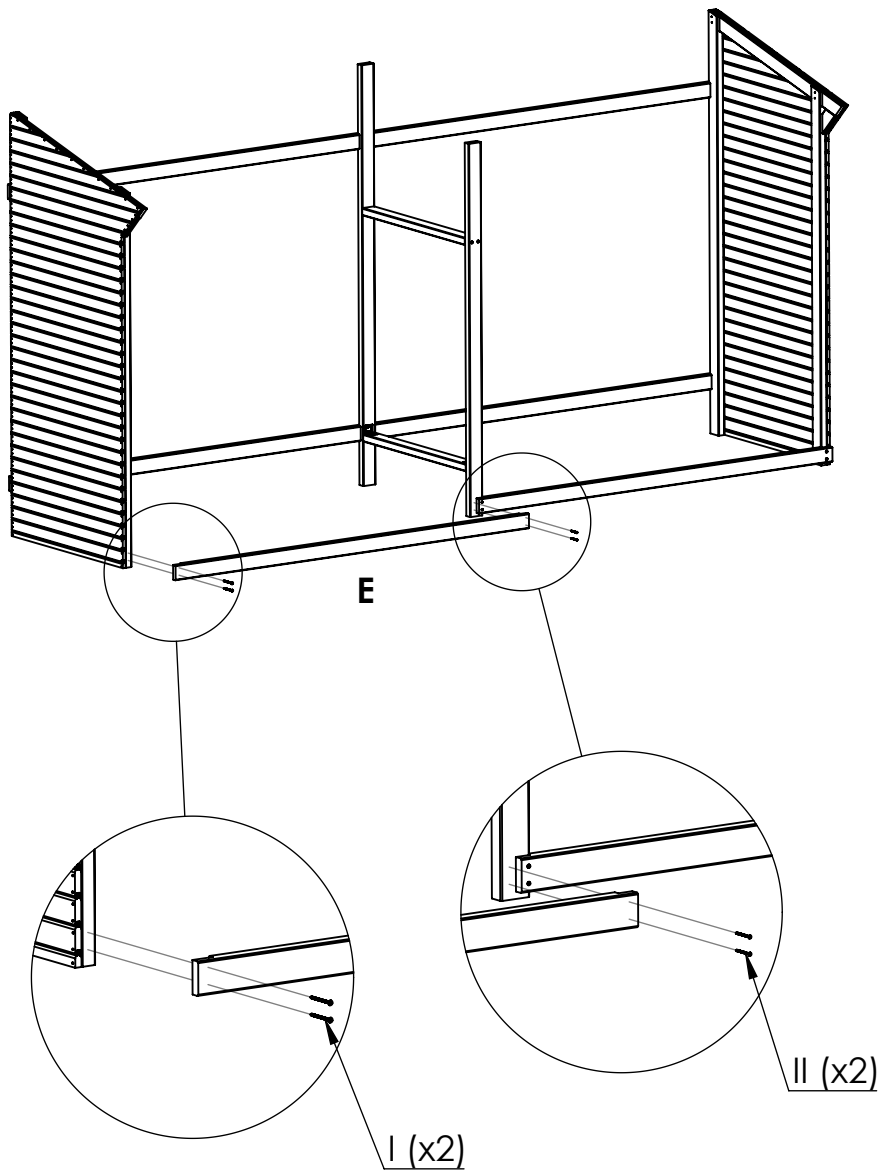

7/11

F x4
I x8

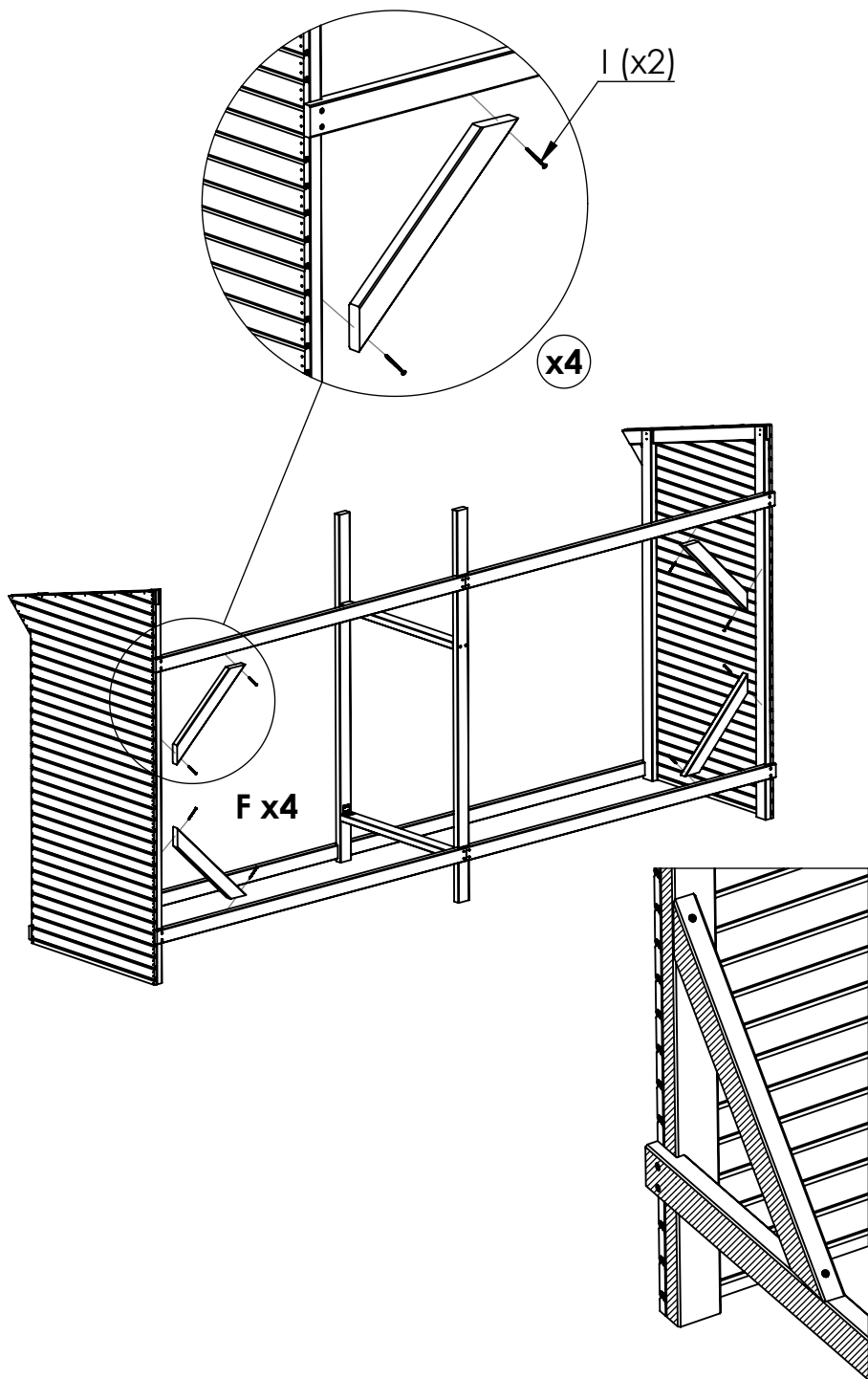

8/11

C x1
D x1
III x6

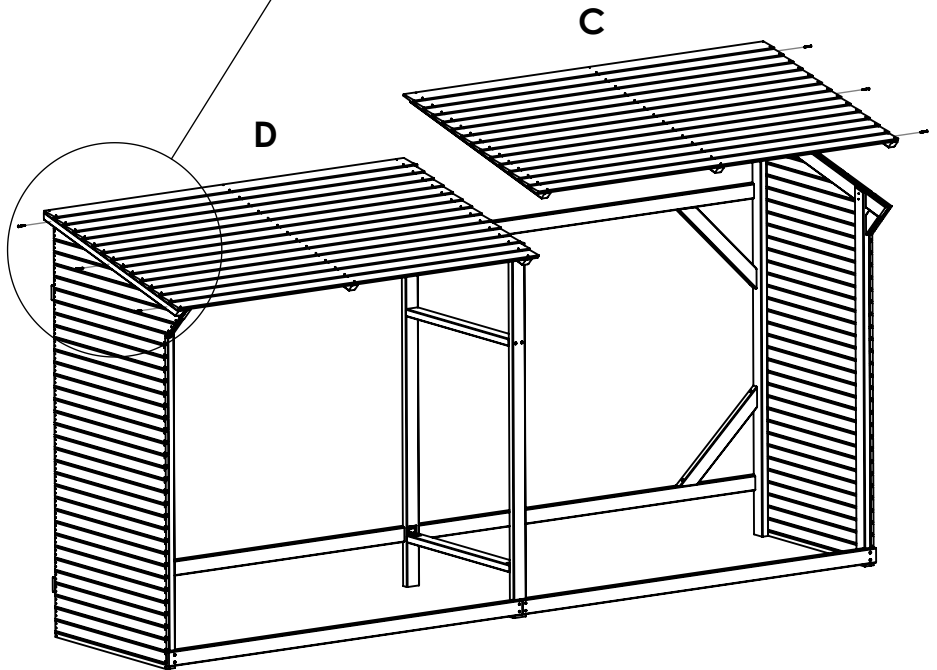
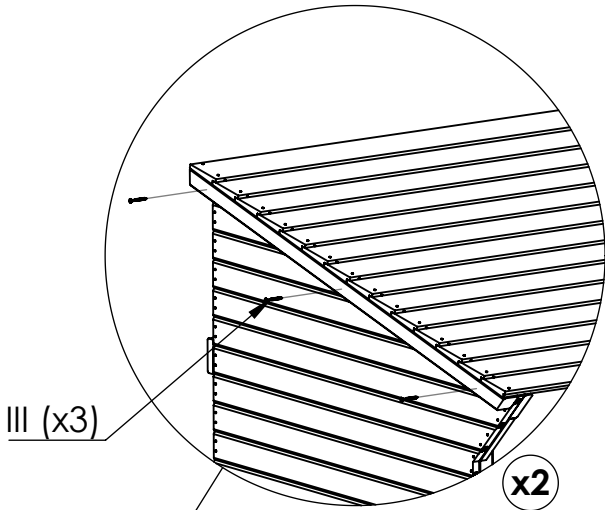

9/11

II x4

II (x4)

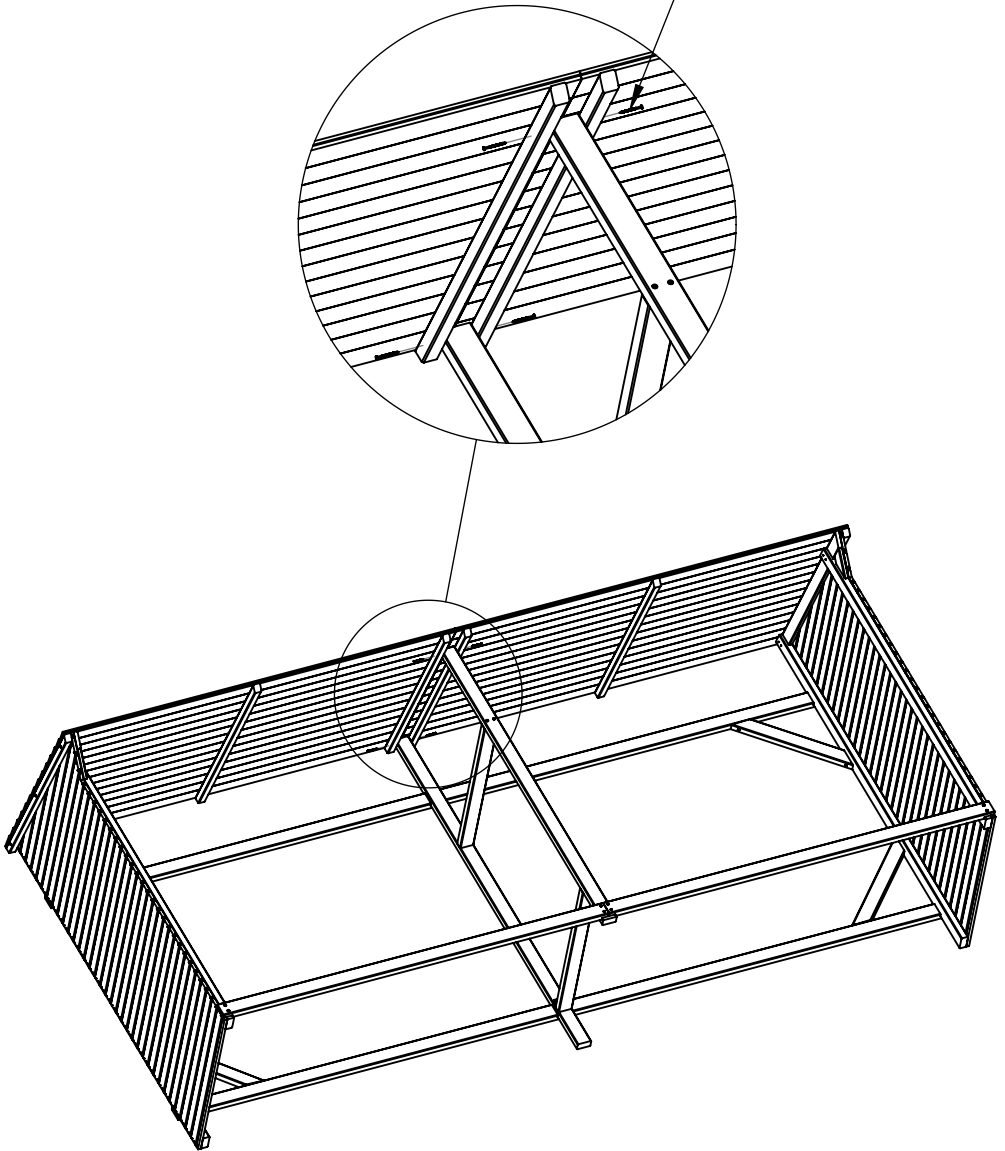

10/11

G x4
III x12

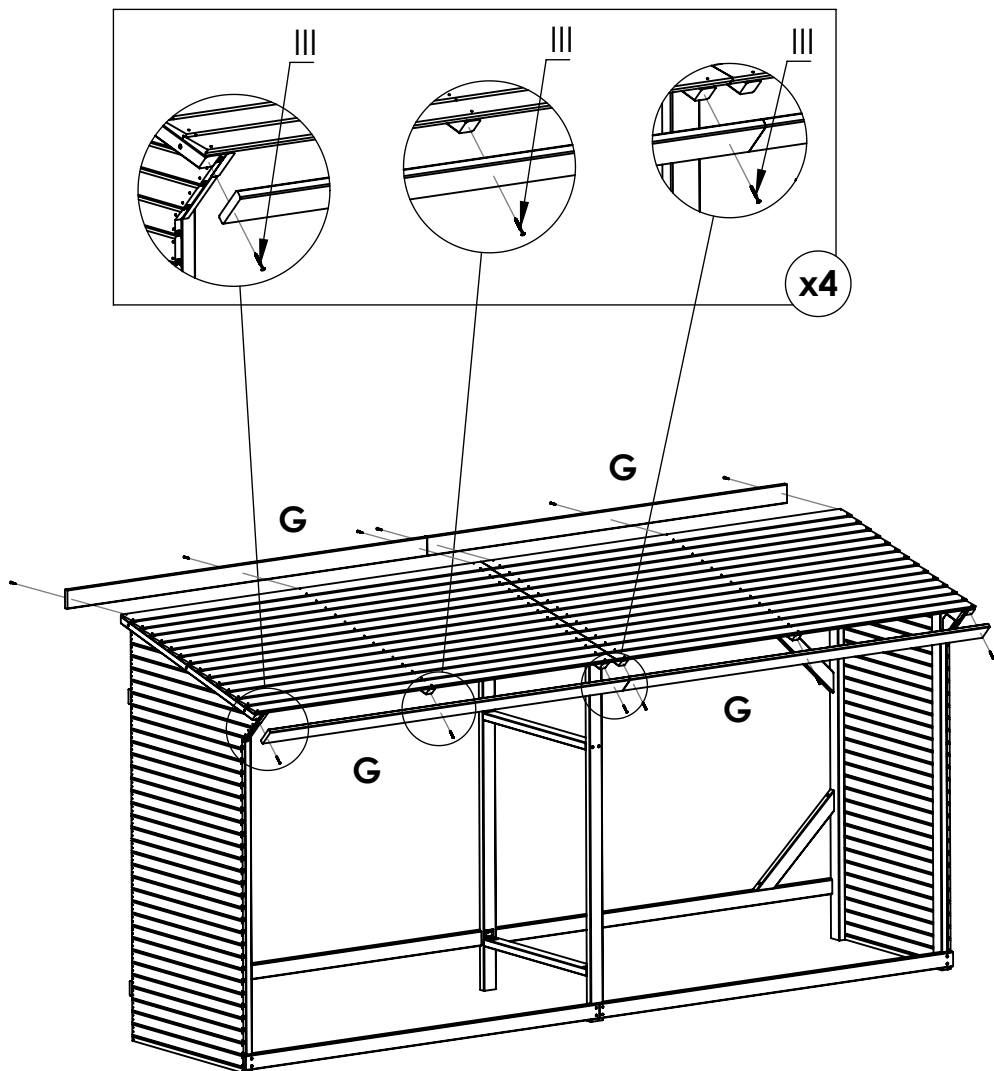

11/11

H x2

III x6

