

INSTALLATION MANUAL

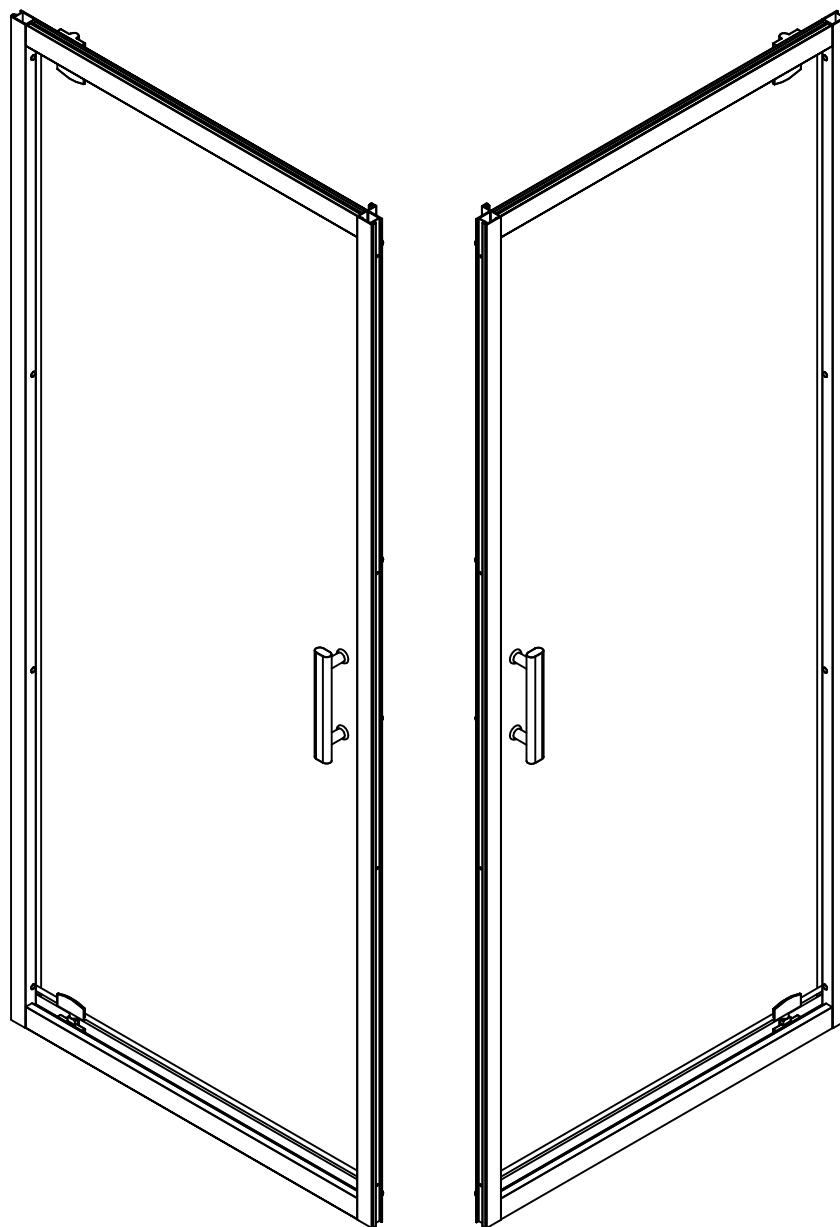

FSE18280(790-805)X1900

FSE18290(890-905)X1900

CONSEILS MONTAGE ET ENTRETIEN

A lire impérativement avant installation :

- 1) Avant de commencer l'assemblage, déballer toutes les pièces et contrôler leur état.
- 2) Les parties en verre sont en verre trempé. Sous l'effet d'un choc, elles peuvent exploser en une multitude de très petits morceaux. Ces éléments nécessitent une **manipulation délicate**. Vous pouvez les protéger en les posant sur des couvertures ou des morceaux de moquette.
- 3) Pour plus de facilité et de rapidité lors du montage nous vous conseillons d'être à **2 personnes**.

Nettoyer et entretenir sa paroi :

- 1) Nettoyage régulier : utiliser un chiffon doux avec un détergent au pH neutre. En cas de difficulté à enlever la saleté, utiliser du vinaigre blanc d'alcool dilué avec de l'eau puis rincer à l'eau claire.
- 2) Nettoyage du tartre : utiliser un chiffon doux et du jus de citron et/ou du vinaigre blanc d'alcool chaud puis rincer à l'eau claire.
- 3) **Ne jamais utiliser** de nettoyeur contenant des grains de polissage, d'acétone, de chlore, d'ammoniaque (javel) ou tout autre nettoyeur agressif à base d'acide.

Conditions de garantie :

- 1) Nos produits sont **garantis 2 ans, pièces uniquement, hors casse. Ne prend pas en compte la main d'œuvre**. La garantie s'exerce au domicile du revendeur, coût de transport et de démontage à la charge du client.
- 2) **Non application de la garantie** : montage incorrect, défaut d'entretien, calcaire, accident ou choc, utilisation de produits abrasifs ou corrosifs, modification du revêtement de surface d'origine.
- 3) Conserver la notice ainsi qu'un document officiel d'achat (facture, ticket de caisse) pour toute réclamation ou demande de pièces détachées.

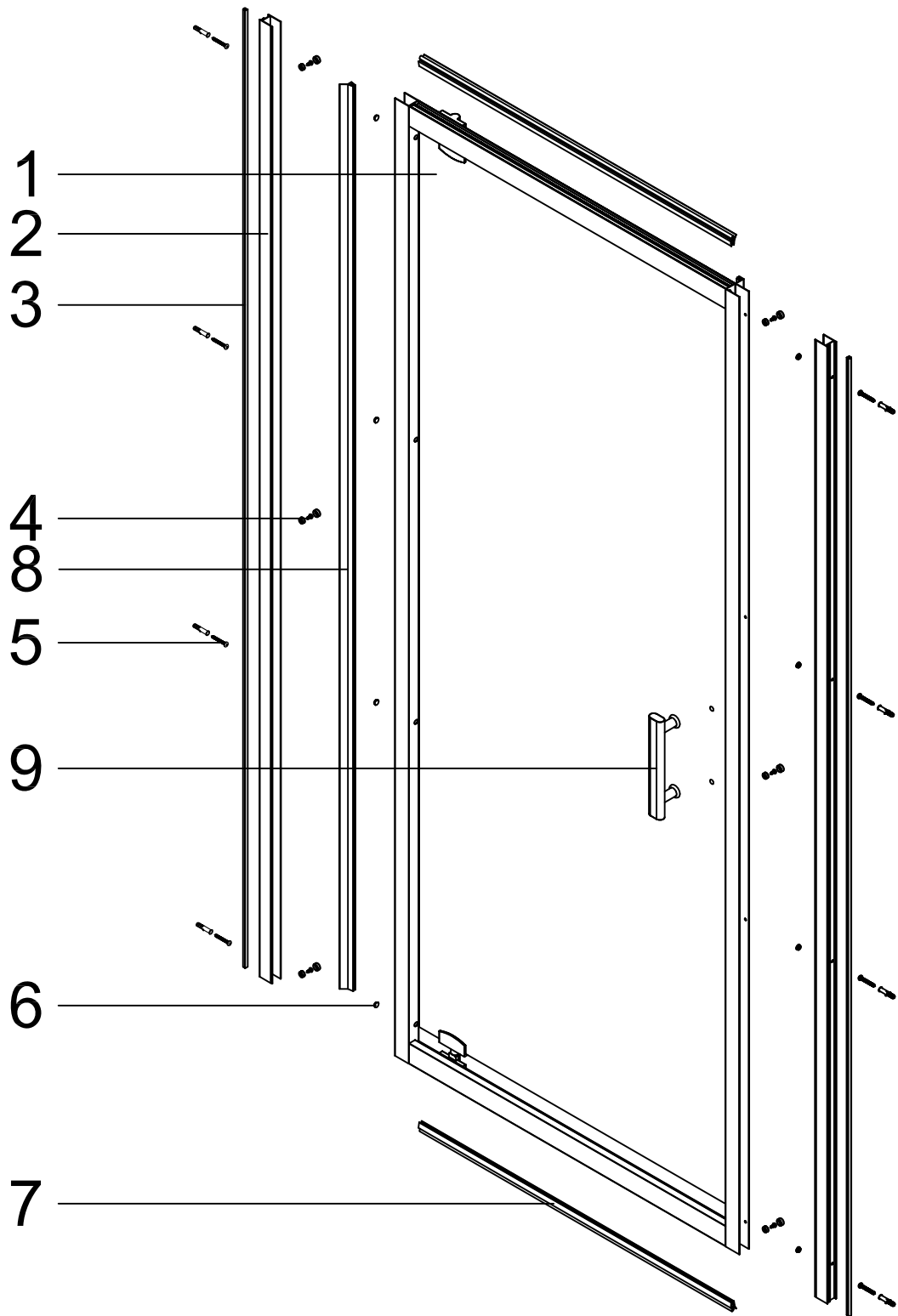

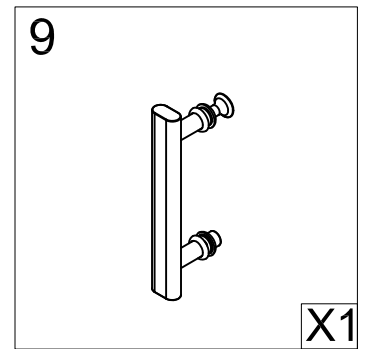
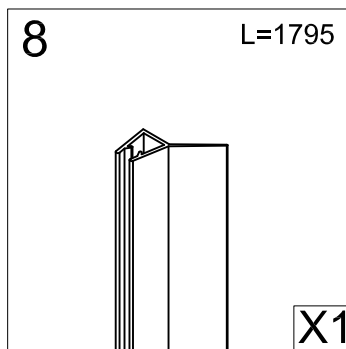
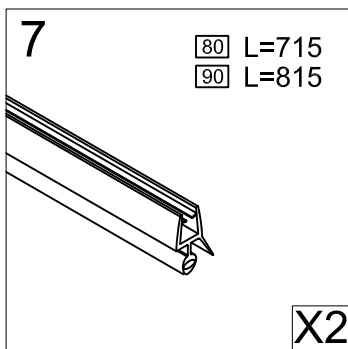
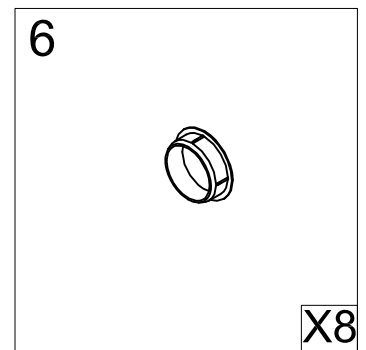
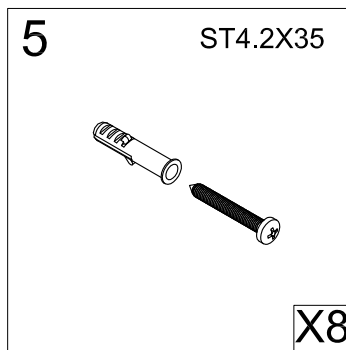
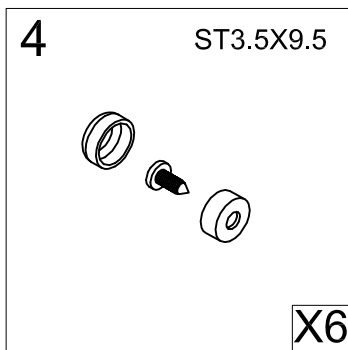
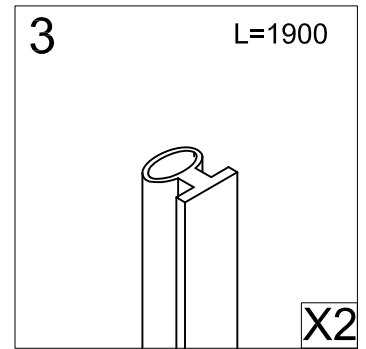
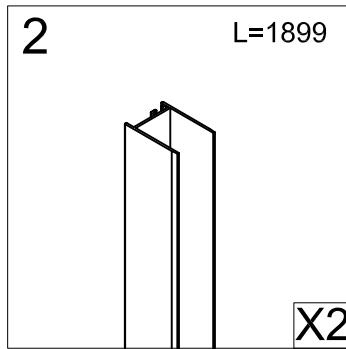
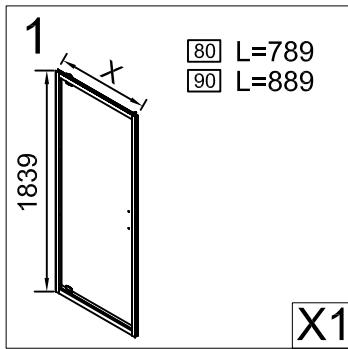
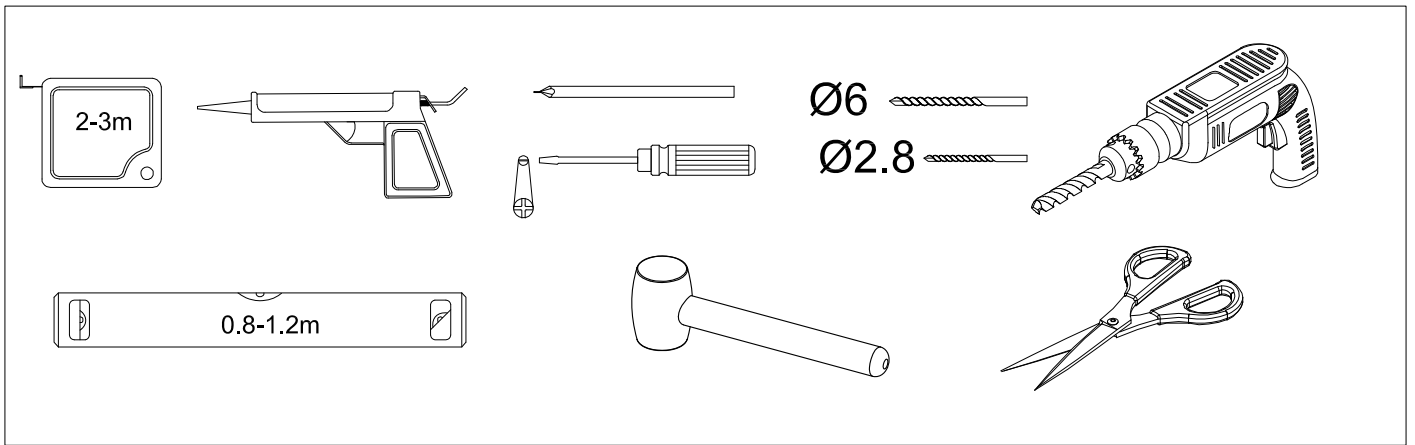

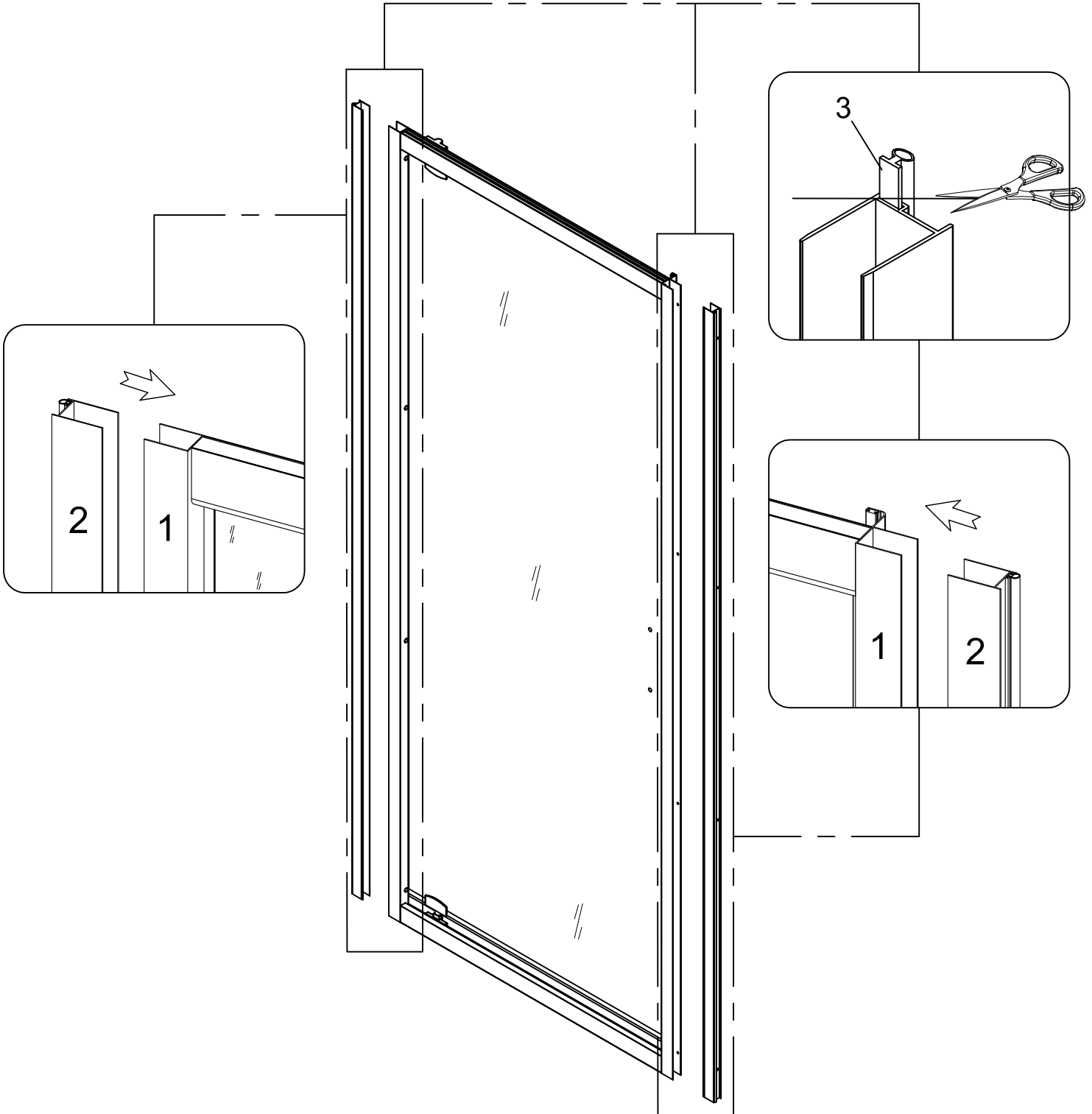
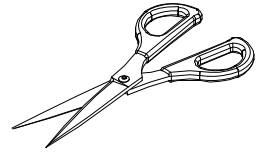
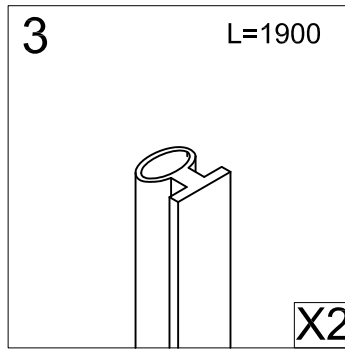
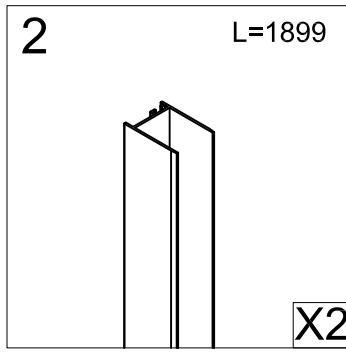
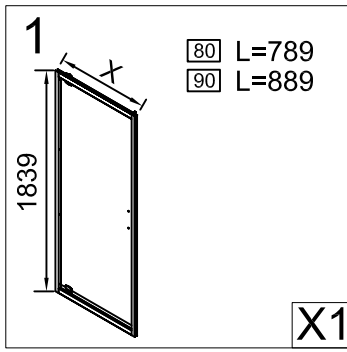

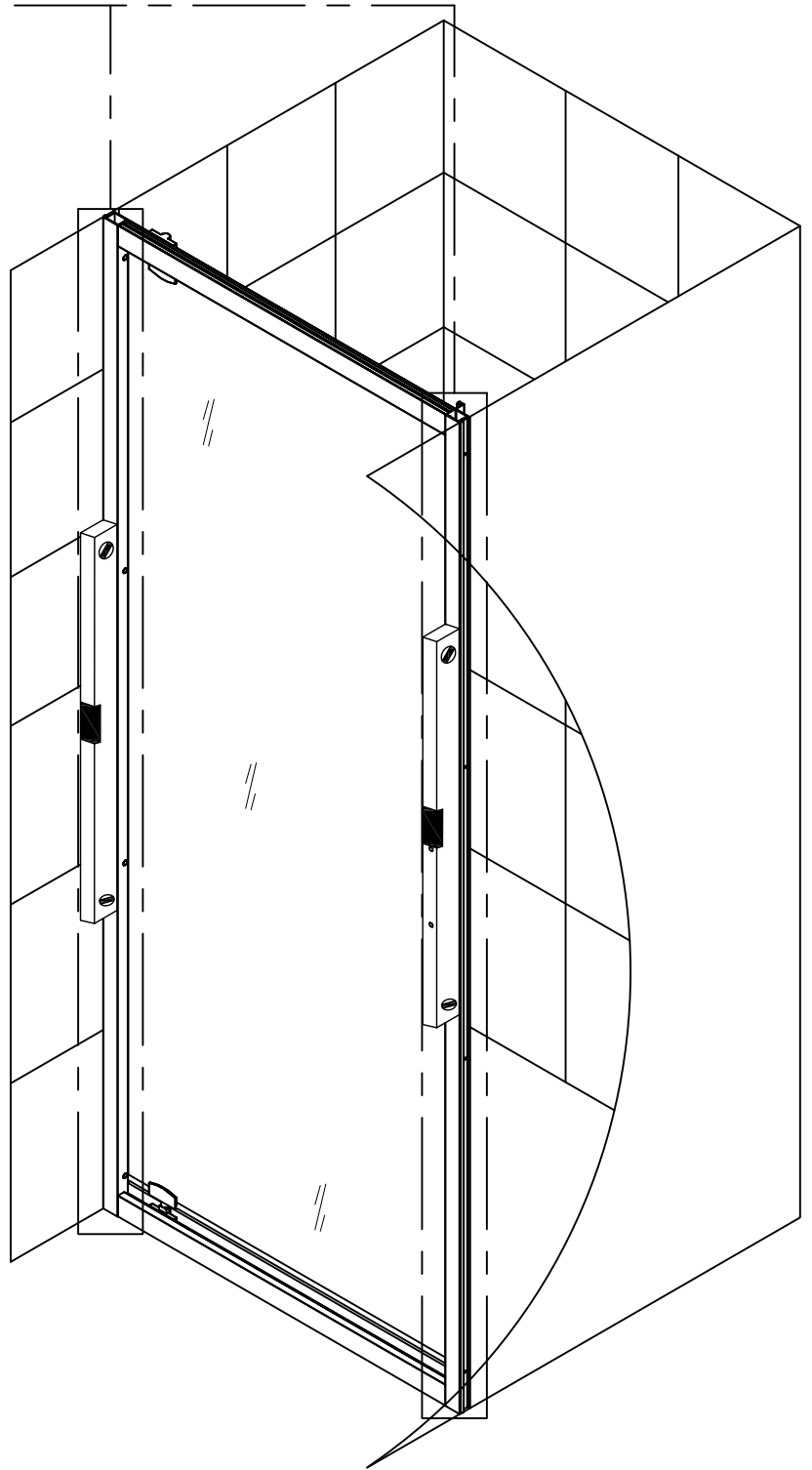
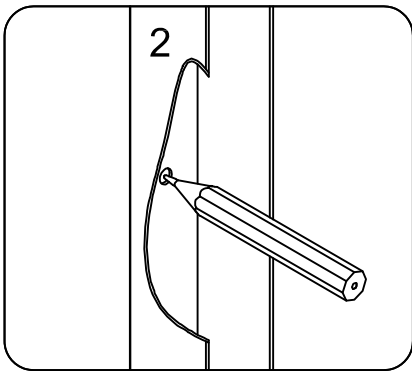
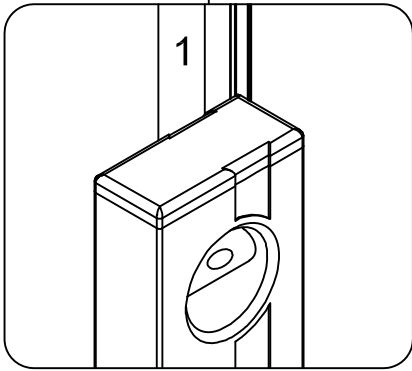
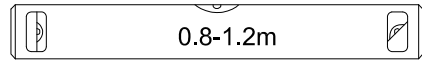
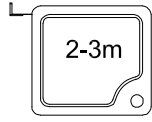
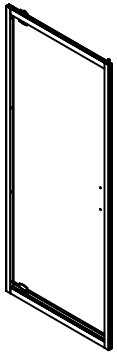

5

ST4.2X35

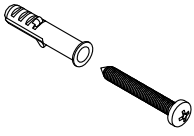

X8

Ø6

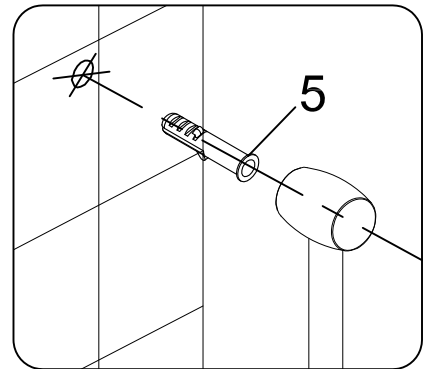
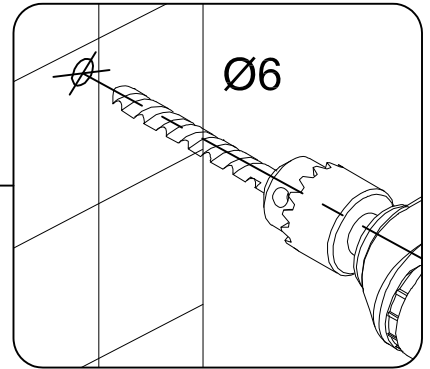
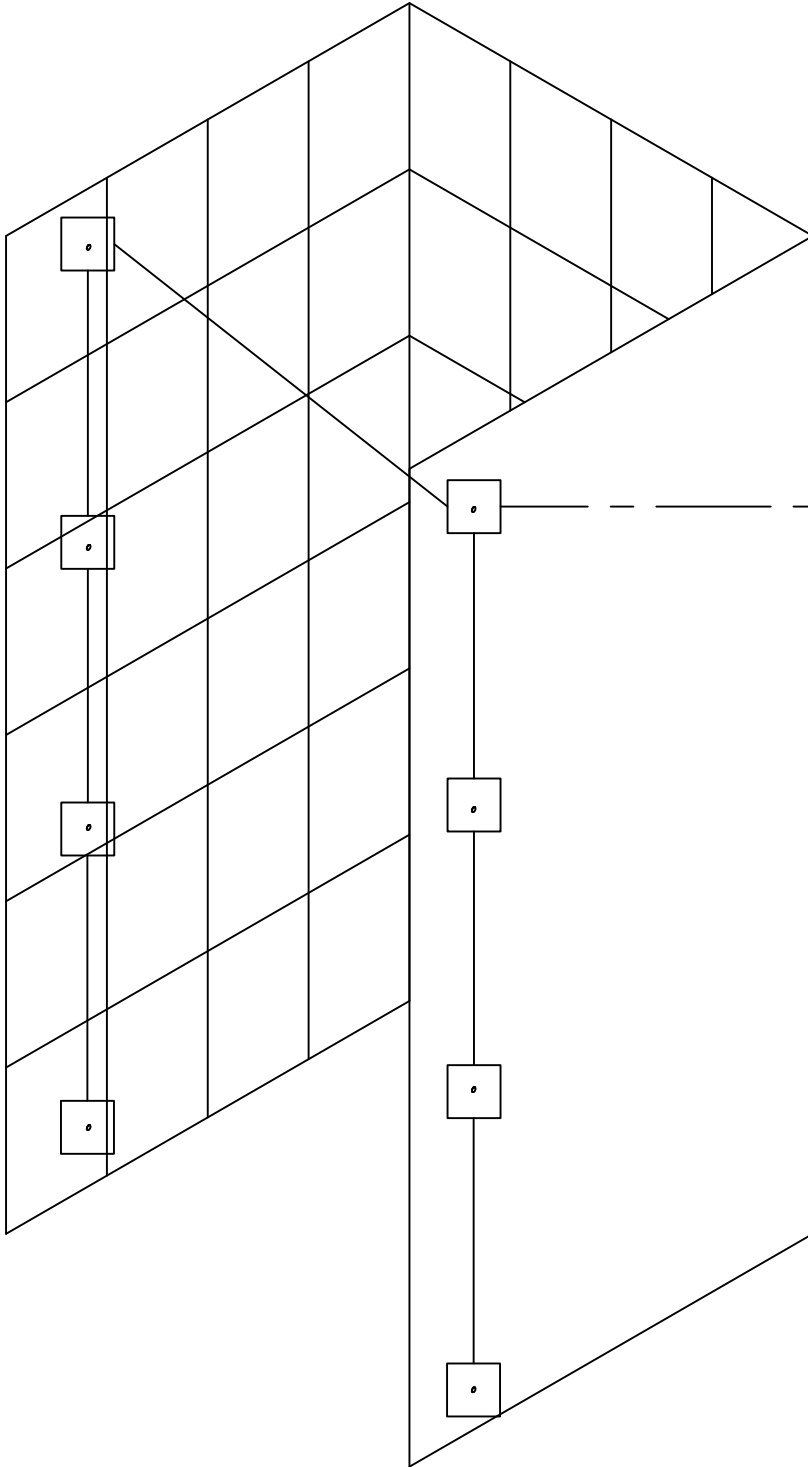
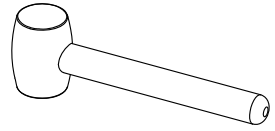
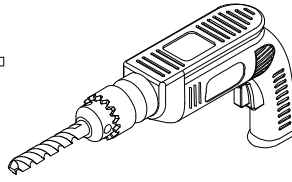

5

ST4.2X35

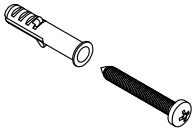

X8

4

ST3.5X9.5

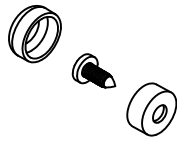

X6

6



X8

Ø6

