

# FAR TOOLS®



## PRO NET70B Professional Machine

FR	Aspirateur Industriel ( Notice originale )
EN	Industrial vacuum cleaner ( Original Manual translation )
DE	Industriestaubsauger (Übersetzung aus dem Original-Anleitung)
ES	Aspirador Industrial ( Traducción del manual de instrucciones originale )
IT	Aspiratore Industriale ( Traduzione dell'avvertenza originale)
PT	Aspirador Industrial ( Tradução do livro de instruções original )
NL	Industriële stofzuiger (Vertaling van de originele instructies)
EL	Επαγγελματική σκούπα νερού και σκόνης (Μετάφραση από τις πρωτότυπες οδηγίες )
PL	Odkurzacz przemysowy (Tłumaczenie z oryginalnej instrukcji)
FI	Teollisuuskäyttöön tarkoitettu polynimuri ( Käännös alkuperäisestä ohjeet )
SV	Industriell sugapparat (Översättning från originalinstruktioner)
BU	Комбинирана промишлена прахосмукачка за прах и вода (Превод на оригиналната инструкция)
DA	Industristøvsuger til vand og støv (Oversættelse fra oprindelige brugsanvisning)
RO	Aspirator industrial apă și praf (Traducere din instrucțiunile originale)
RU	Промышленный уловитель воды и пыли (Перевод с оригинальной инструкции)
TU	Su ve toz sinai aspiratörü (Orijinal talimatlar çeviri)
CS	Průmyslový odsavač vody a prachu (Překlad z originálního návodu)
SK	Priemyselný odsávač vody a vzduchu (Preklad z originálneho návodu)
HE	תיוקומ תוארומה סוגרת) הניעט ומז
AR	(فيلسوا) تامياعدا نم قمجردلا) ليمحتلا نجز
HU	Ipari víz- és porszívó (Fordítás az eredeti utasítások)
SL	Industrijski sesalnik za suho in mokro sesanje (Prevod iz izvornih navodil)
ET	Tööstuslik vee- ja tolmuimeja (Tõlge originaal juhiseid)
LV	Pramoninis plaunamas dulkiu siurblys (Tulkojumā no instrukcijas oriģinālvalodā)
LT	Rūpnieciskais un putekļu putekšsūcėjs (Vertimas iš originalių instrukcijas)
HR	Industrijski usisivač (Originalne upute)



© FAR GROUP EUROPE

101256-2-Manual-G-20230228



[fartools.com](http://fartools.com)

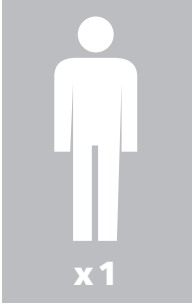

**10 min**

Description et repérage des organes de la machine  
Description and location of machine parts

A



Contenu du carton  
Contents of box

C



# D

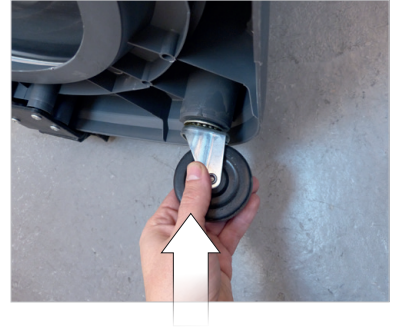
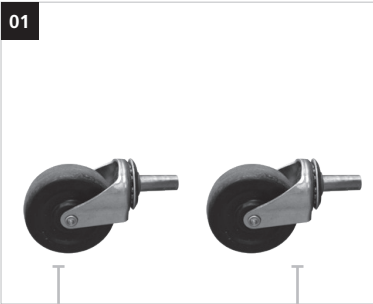

11

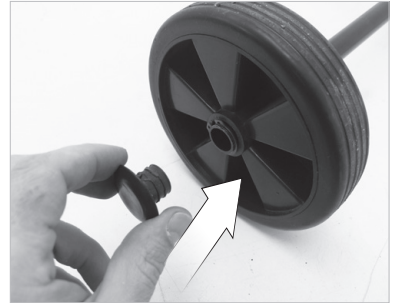

10





01



06

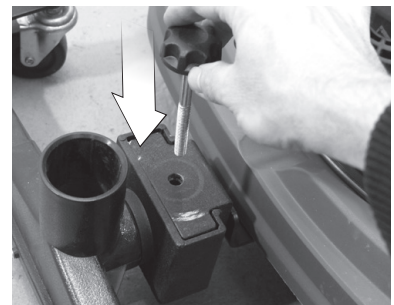
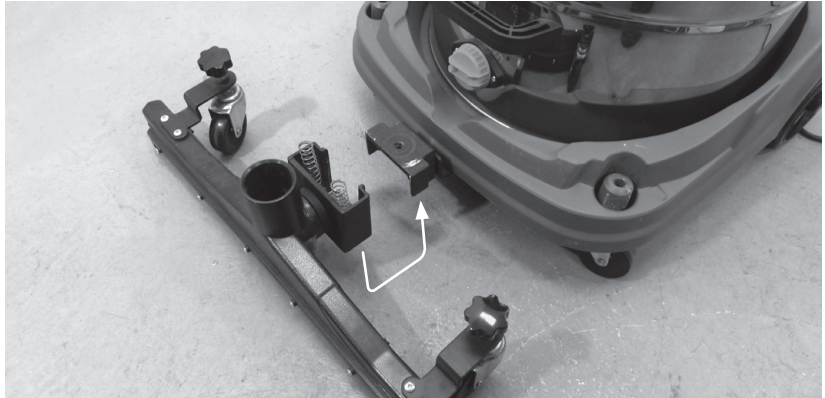
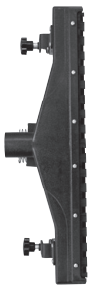

Assemblage de la machine  
Assembling the machine

D

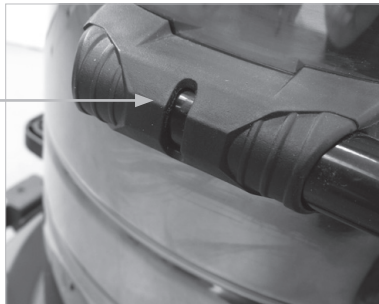
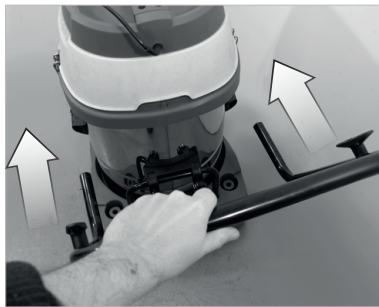
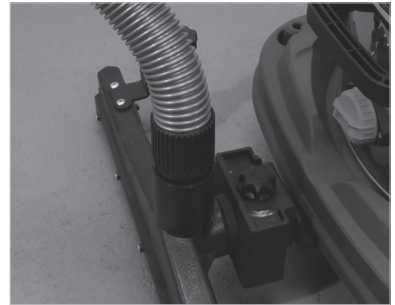
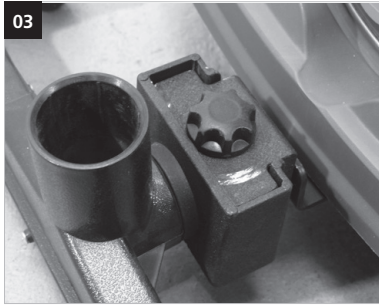



X 2

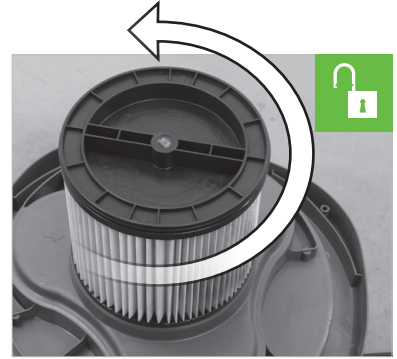
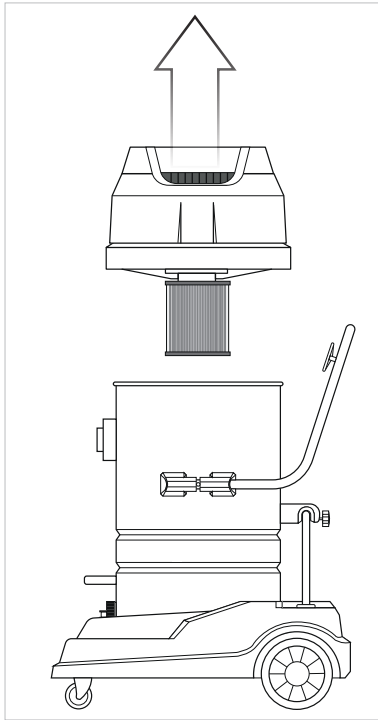
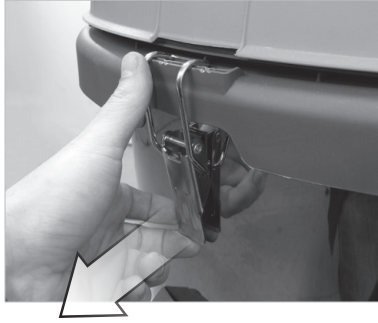

Οption - Option - Option - Opcional - Opzione - Opção - Optie - Επιλογή - Opcja - Valinnainen - Tillval - Дод-  
пльнительно - Ekstra udstyr - Opřine - Опция - seçenek / seçim - Volba - Vólba - Μύσηγη - راييخ - Opció  
- Možnost - Valik - Opcija - Izvele

REF : 101862



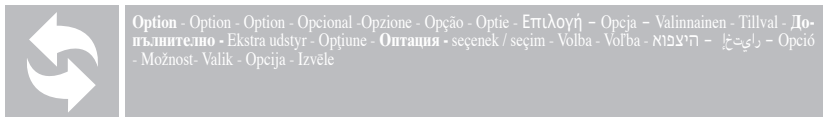
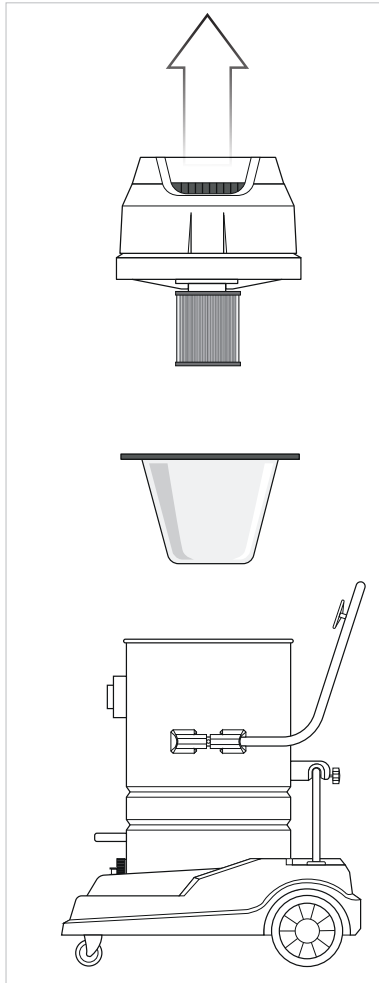

REF : 101861



# E

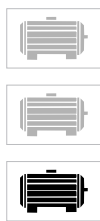
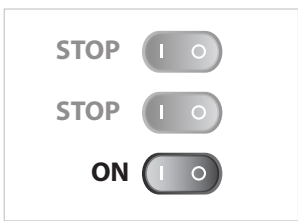
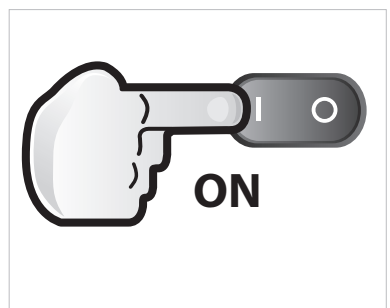
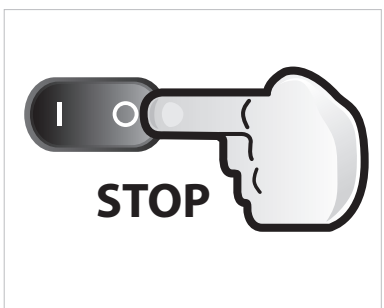
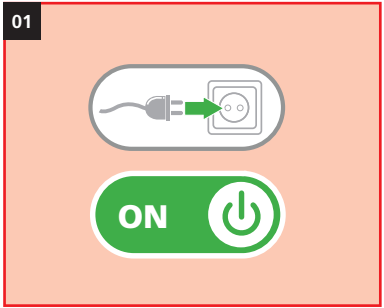

**= 1000 W**

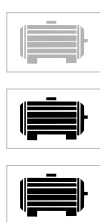

**= 2000 W**

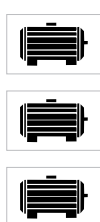

**= 3000 W**

Remplacement des consommables  
Consumables replacing

# G

01

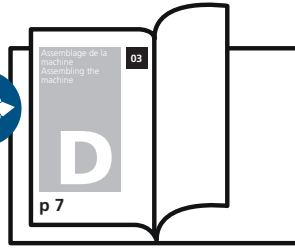

Entretien, recommandations et conseils  
Maintenance, recommendations and advice

# H

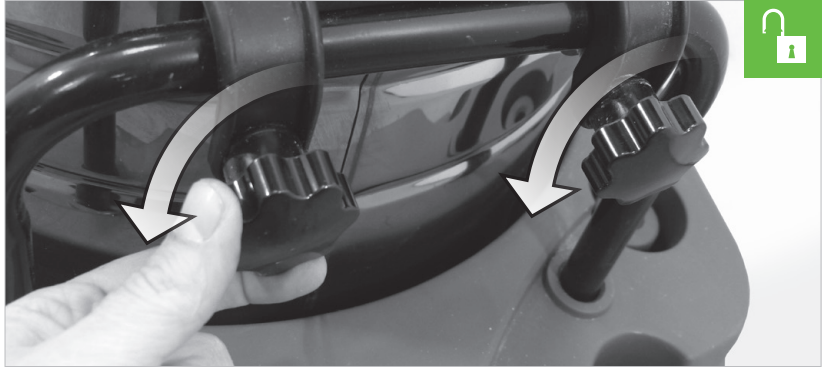

06

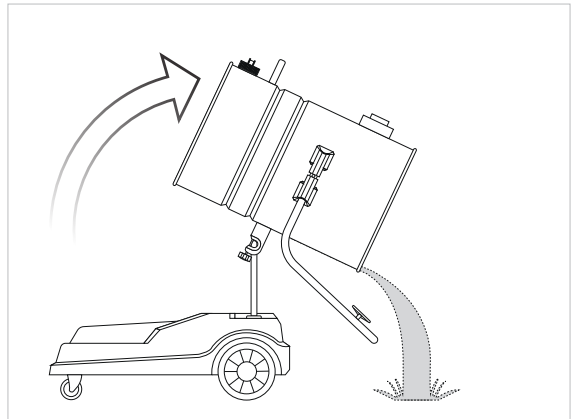
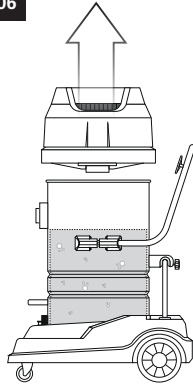



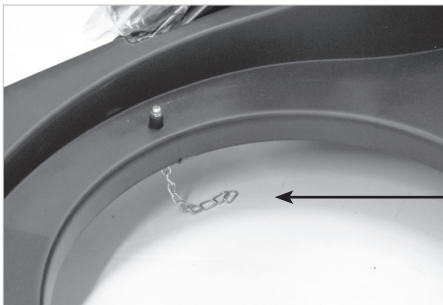
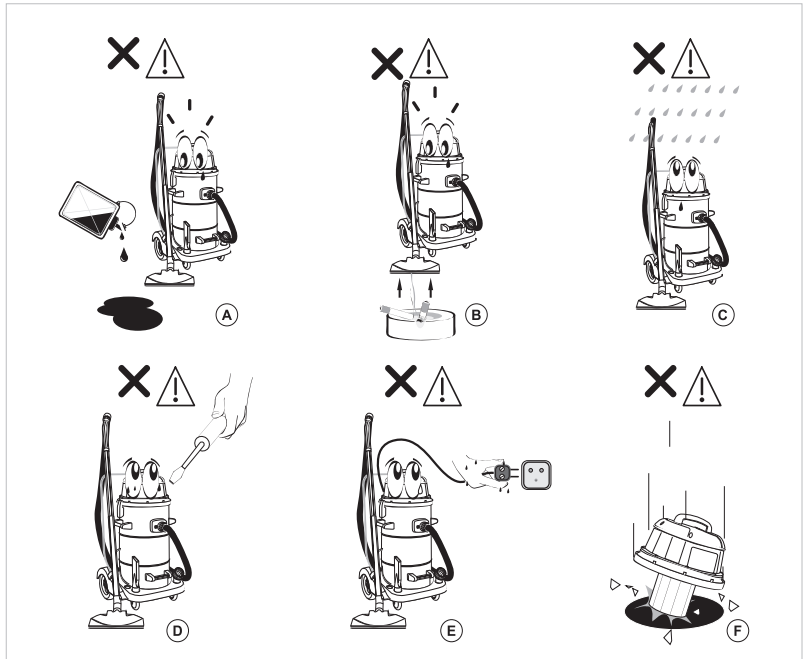
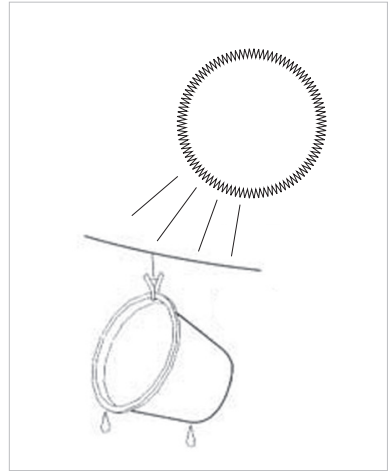





Entretien, recommandations et conseils  
Maintenance, recommendations and advice

# H



- (A) Bouchon flotteur  
Vlotter stopper  
Float stopper  
Tapón del flotador  
Float rolha  
Float stopper
- (B) Entrée d'air - accès au filtre  
Luchtinlaat - toegang filter  
Entrada de aire - acceso al filtro  
Entrada de ar - de acesso ao filtro  
Air inlet - filter access

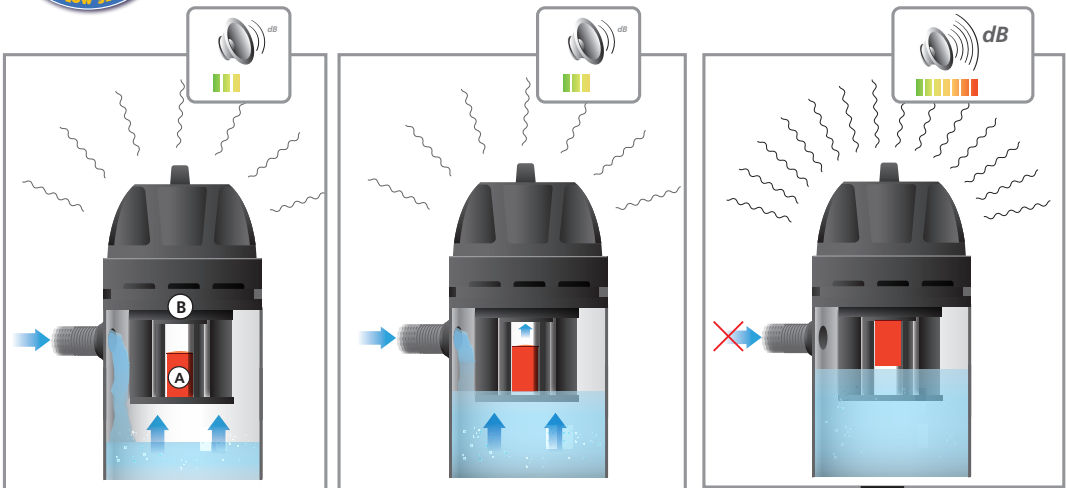

Attention ! lorsque le flotteur atteint le haut, le bruit du moteur augmente fortement mais celui-ci ne s'arrête pas ! Il est recommandé de stopper l'aspirateur immédiatement et de procéder à la vidange de la cuve !

Kijk Uit! wanneer de vlotter voor de top bereikt, motorgeluid sterk toeneemt, maar dit houdt niet op! Het wordt aanbevolen om onmiddellijk te stoppen stofzuigen en ga verder met de tank af te tappen!

Cuidado! cuando el flotador llega a la cima, el ruido del motor aumenta bruscamente, pero esto no se detiene! Se recomienda dejar pasar la aspiradora inmediatamente y proceder a drenar el tanque!

Cuidado! quando o flutuador atinge o topo, o ruído do motor aumenta acentuadamente, mas isso não pare! Recomenda-se a interromper a aspiração imediatamente e prosseguir para drenar o tanque!

Attento! quando il galleggiante raggiunge la parte superiore, il rumore del motore aumenta bruscamente, ma questo non si ferma! Si raccomanda di interrompere l'aspirazione immediatamente e procedere svuotare il serbatoio!

Watch Out! when the float reaches the top, engine noise increases sharply but this does not stop! It is recommended to stop vacuuming immediately and proceed to drain the tank!



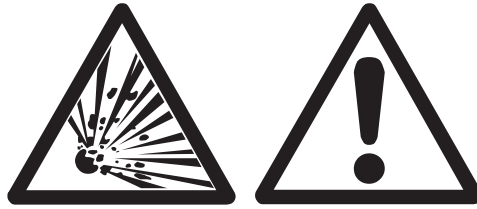



- Ne pas aspirer de farine avec cet appareil
- Do not vacuum flour with this machine
- Kein Mehl mit diesem Gerät absaugen
- No se puede aspirar harina con este aparato
- Non aspirare della farina con questo apparecchio
- Não aspirar farinha com este aparelho
- Gebruik dit toestel niet om meel op te zuigen
- Μην αναρροφάτε άλευρα με την συσκευή αυτή.
  - Nie wdychać pyłów
  - Älä ime jauhoja tällä laitteella
- Sug inte upp mjöl med den här apparaten
- Не събирайте брашно с тази машина
  - Sug ikke mel op med dette apparat
  - Nu aspirați făină cu acest aparat
- Запрещается использовать устройство для всасывания металлических опилок
  - Bu cihazı kullanırken toz yutmayın
  - S přístrojem neodsávejte mouku
  - Týmto přístrojom nenasávajte múku
- אין לבצע שאיבת קמח באמצעות מכשיר זה
  - لا تشفط الطحين بهذا الجهاز -
  - Ne szívjon fel lisztet a készülékkel
  - S to napravo ne vsesavajte moke
    - Tolmu mitte sisse hingata
  - Su šiuo aparatu neįkvėpti dulkių.
    - Neieelpot ar šo ierīci puteklus

	<p>Tension et fréquence assignée: Nominal frequency and power: Spannung und Frequenz: Tensión y frecuencia fijada: Tensione e frequenza assegnata: Tensão e frequência fixa: Aangewezen spanning en frequentie: Όνομαστική τάση και συχνότητα: Napięcie i częstotliwość przydzielona: Jännite ja määrätty taajuus: Angiven spänning och frekvens: Anført spænding og frekvens: Tensiune și frecvență de lucru:</p>	<p><b>Заданное напряжение и частота:</b> Tahsis gerilimi ve frekansı: Stanovené napětí a frekvence: Stanovené napätie a frekvencia: מחמת ותדר מוקצב الفلطية والذبذب المبرمج. Névléges feszültség és frekvencia: Napetost in določena frekvenca: <b>Консумирано напрежение и честота :</b> <b>Määratud pinge ja sagedus</b> <b>Nustatytā jūtampa ir dažnis</b> <b>Noteiktāis spriegums un frekvence.</b> Napon i nazivna frekvencija:</p>	<b>230 V ~ 50 Hz</b>
---	--	--	----------------------

	<p>Puissance assignée: Nominal power: Leerlaufdrehzahl: Potencia fijada: Potenza assegnata: Potência assinada: Onbelast toerental: Όνομαστική ή ισχύς : Prędkość na biegu jałowym: Teho: Angiven effekt: Anført styrke: Putere de lucru:</p>	<p><b>Заданная мощность:</b> Tahsis edilen gücü: Stanovený příkon: Predpísaný výkon: כוח מוקצב. القدرة المبرمجة. Névléges teljesítmény : Določena jakost: <b>Консумирана мощност:</b> <b>Määratud võimsus.</b> <b>Nustatytā galia</b> <b>Noteiktā jauda</b> Nazivna snaga:</p>	<b>3000 W</b>
---	--	--	---------------

	<p>Classe d'isolement : 2 Insulation class : 2 Isolierung klasse : 2 Aislamiento clase :2 Isolamento classe :2 Isolamento classe :2 Isolatie Klasse : 2 Εργαλειο τάξη : 2 Izolacja Klasy :2 Eristysluokka :2 Isolering Klass :2 Isoleringsklasse 2 Clasă izolație :2</p>	<p><b>Класс изоляции 2 :</b> Yalıtım derecesi :2 Třída izolace :2 Izolačný systém 2 סוג בידוד 2 فئة العزل 2 Szigetelési osztály :2 Razred izolacije :2 <b>Инструмент Клас :2</b> <b>Isolatsiooniklass 2</b> <b>Izolācijas rūšis 2</b> <b>Izolācijas klase 2</b> Izolacija klasa: 2</p>	<b>X</b>
--	--	--	----------

	Porter des lunettes de sécurité : Wear protective eyewear : Schutzbrille tragen : Llevar puestas gafas protectoras : Portare de gli occhiali di sicurezza : Utilizar óculos de segurança : Draag een veiligheidsbril : Φορέστε Προστατευτικά γυαλιά : Zakładać okulary ochronne : Käytä suojalaseja : Använd skyddsglasögon : Der skal benyttes sikkerhedsbriller : Purtati ochelari de protecție :	<b>Наденьте защитные очки :</b> Güvenlik gözlükleri takın : Ποιζίβεjte bezpečnostní brýle : Noste ochranné okuliare : תוהיטב יפקשמ בכרהל אן حامل نظارات وقاية. Viseljen védőszemüveget : Nositi zaščitna očala : <b>Да се използват защитни очила :</b> Kandke kaitseprille Nešioti apsauginius akinius Valkät aizsargbrilles Nositi zaštitne naočale:	X
---	---	--	---

	Porter un masque anti-poussière : Wear a dust mask : Staubschutzmaske tragen : Llevar puesta una careta de protección contra el polvo : Indossare una mascherina anti-polvere : Utilizar uma máscara anti-poeira : Draag een stofmasker : χρήση προστατευτική μάσκα : Zakładać maskę przeciwpyłową Käytä pölysuojut : Bär mask mot damm : Der skal benyttes beskyttelsesmaske mod støv: Purtati mască anti-praf :	<b>Наденьте респиратор :</b> Toza karşı maske takın : Používejte masku proti prachu : <b>Noste ochrannú masku proti prachu :</b> קבא דגנ הכסמ שובחל אן لبس قناع مضارض للغيبار. Viseljen porvédő maszkot Nositi zaščitno masko proti prahu: <b>Да се използва защитна маска :</b> Kandke tolmumaski. Dėvėti respiratorių Valkät aizsarg masku pret putekļiem Nositi masku za zaštitu od prašine:	X
---	---	---	---

	Porter une protection auditive : Wear hearing protective equipment: Gehörschutz tragen: Llevar puesta una protección auditiva: Portare una protezione uditiva: Utilizar uma protecção auditiva: Draag gehoorbeschermers: Φορέστε Προστατευτικά ακουστικά Zakładać słuchawki ochronne Käytä kuulosuojaimia: Bär hörselskydd: Der skal benyttes høreværn: Purtati căști de protecție auz:	<b>наденьте средства звуковой защиты:</b> İşitsel koruma aleti takın: Používejte ochranu sluchu: Noste ochranné slúchadlá: יש ל הרכיב הגנת שמיעה لبس خوذة خضض الخرجىج Viseljen fülvédőt Nositi zašito ušes: <b>Да се използва слухови защитни средства:</b> Kandke kõrvakaitset Nešioti apsaugą nuo triukšmo Valkät dzirdes aizsarglīdzekli Nositi štítnike protiv buke:	X
--	---	--	---

	Porter des gants : Use rubber gloves : Schutzhandschuhe tragen : Llevar guantes de protección : Indossare i guanti di protezione : Utilizar luvas de protecção : Draag veiligheidshandschoenen : χρήση προστατευτικών γαντιών : Używać rękawic ochronnych : Käytä suojakäsineitä : Använd skyddshandskar : Der skal benyttes handsker : Purtati mănuși :	<b>Наденьте перчатки :</b> Eldiven takın : Noste rukavice : Noste rukavice : תופכ שובלל אן لبس قفازات. Viseljen kesztyű t Nositi rokavice: <b>a se използват предпазни ръкавици :</b> Kandke kindaid Müvėti pirštines Valkät cimdus Nositi zašitne rukavice:	X
---	--	--	---

	<p>Lire les instructions avant usage :          Read the instructions before use :          Vor Einsatz des Geräts Anweisung lesen :          Léase las instrucciones antes de usar :          Leggere le istruzioni prima dell'uso :          Ler as instruções antes da utilização :          Lees voor het gebruik de instructies :          Διαβίστε τις οδηγίες χρήσης :          Zapoznać się z instrukcją przed użyciem :          Lue ohjeet ennen käyttöä :          Läs anvisningarna före användning :          læs instruktionerne før brug          Înainte de utilizare, citiți instrucțiunile :</p>	<p><b>Внимательно прочитайте следующие инструкции :</b>          Kullanmadan talimatları okuyunuz :          Pozorně si přečtěte následující pokyny :          Pred použitím si prečítajte pokyny :          זרם חילופי          اقرأ التعلیمات قبل الاستخدام          használat előtt olvassuk el az utasítást :          Pred uporabo preberite ustrezna navodila  <b>Прочетете указанията за употреба :</b>  <b>Enne kasutamist lugege instruksiooni</b>  <b>Prieš naudojimą perskaityti instrukciją</b>  <b>izlasīt instrukcijas pirms lietošanas</b>          Pročitati upute prije uporabe:</p>	<b>X</b>
---	--	---	----------

	<p>Conformité européenne          Conforms to EC standards :          CE-Konformität :          Cumples con las directivas CE :          Conforme alle norme CE :          Conforme às normas CE :          Voldoet aan de EG-normen :          Συμφώνο με τα πρότυπα          Zgodność z normami CE :          EU-standardien mukainen :          EU-standardien mukainen :          Overholder EU standarderne :          Conform cu normele europene:</p>	<p><b>соответствие европейским стандартам:</b>          Avrupa uygunluk :          evropská shoda :          európska dohoda :          התאמה לתקנים האירופיים          مطابق للمواصفات الأوروبية.          evropska ustreznost :          európai megfelelőség :  <b>Съответствие с европейските норми :</b>          Euroopa Liidu vastavusmärk          Europinių normų atitikima          Atbilstība Eiropas standartiem          Euroopska sukladnost</p>	<b>X</b>
---	--	--	----------

	<p>Danger :          Danger :          Gefahr :          Peligro :          Pericolo :          Perigo :          Gevaar :          Κινδύος :          Niebezpieczeństwo :          Vaara :          Fara :          Fare :          Pericol :</p>	<p><b>Опасно :</b>          Tehlike :          Nebezpečí :          Nebezpečnosto :          סכנה.          خطر.          Veszély :          Nevarnost:  <b>Опасност :</b>  <b>Oht</b>  <b>Pavojus</b>          Bistamība          Opasnost:</p>	<b>X</b>
---	--	--	----------

	<p>Poids :          Weight :          Gewicht :          Peso :          Peso :          Peso :          Gewicht :          Βάρος :          Masa :          Paino :          Vikt :          Vægt :          Greutate :</p>	<p><b>Вес :</b>          Ağırlik :          Hmotnost :          Hmotnost' :          משקל          الوزن.          Súly :          Teža :  <b>Тегло :</b>  <b>Raskus</b>  <b>Svoris</b>  <b>Svars</b>          Težina</p>	2.7 kg
---	--	---	--------

		18 kPa - 50 Us
---	--	----------------

	<p>Soumis à recyclage Subjected to recycling Sujeto a reciclaje Sottoposti a riciclaggio Sujeitos à reciclagem Não deite no lixo : Niet wegwerpen : Μην την πετάτε : Nie wyrzucas : Älä heittä pois luontoon : Batteriet får inte kastas : Bortkast det ikke: Nu le auncati :</p>	<p>Не выбрасывайте в мусорный ящик Atmayiniz : Nevyhadzujte je do bežného odpadu : Neodhadzovat : אין לזרוק סוללות فلا ترممها ملذا في القمامة. ne mečite! Ne odvržite ga/jih vstran : Не го изхвърляйте : Ärge visake seda minema : Nemetykite : Nemest : Podvrgnuto recikliranju</p>	X
---	---	---	---

**Recyclage des déchets :**

Les outils, accessoires et leur emballages doivent suivre une voie de recyclage adaptée. Conformément aux directives Européenne 2012/19/UE et 2006/66/CE, les composants d'un produit doivent être séparés, collectés, recyclés ou éliminés en conformité avec les réglementations environnementales en vigueur. Les appareils, batteries, piles, huiles, emballages devront être déposés dans les systèmes d'élimination des déchets spéciaux tels que déchetteries. Renseignez-vous auprès de votre commune pour connaître l'organisme le plus proche à même de retraiter ou de collecter ces déchets.

	<p>Recyclable, soumis au tri sélectif Recyclable, subject to recycling Recyclingfähige, unterliegen Recycling Reciclables, sujetos a reciclaje Riciclabili, soggetti a riciclaggio Recicláveis, sujeito à reciclagem Recycleerbare, onderworpen aan recycling Ανακυκλώσιμες συσκευασίες που υπόκεινται σε κάθλωση Opakowanie nadaje się do recyklingu podlegają recyklingu Kierrätettävien pakkausten kohteena kierrätys Återvinningsbara förpackningar omfattas återvinning <b>Рециклираци се опаковки подлежат на рециклиране</b> Genanvendelig underlagt genbrug</p>	<p>Reciclabile sub rezerva reciclare <b>Повторно опаковка подлежит вторичной переработке</b> Gerí dönüştürüm Geri dönüştürülebilir ambalaj konusu Recyklovateľné podľehajúci recyklácii Recyklovateľné podliehajúce recyklácii רוחמל רווחמל הייראה אשונ رئودتلا داإعال غرضهت رئودتلا داإعال قلمباؤلا فئول غئلاو غئوئلا Újrahasznosítható csomagolás alá újrahasznosítás Reciklirati predmet recikliranja Pakendite suhtes ringlussevõtu Pärsträdājams iepakojumus otrreizējai pārstrādei Perdirbamų taikomos perdirbimo <b>Može se reciklirati, podložno selektivnom sortiranju</b></p>	X
---	---	---	---

	<p>Capacité cuve : Tank capacity: Volumen der Wanne : Capacidad depósito : Capacità vasca : Capacidade da fina : Capaciteit van de kuip : χωρητικότητα δεξαμενή : Pojemność zbiornika : Säiliön vetävyys : Cisternkapacitet :</p>	<p>beholderkapacitet : capacitate cuvă : <b>объем бака :</b> Kap kapasitesi : kapacita nádoby : obsah nádrže : מידות סמרות. سعة التخزين a kád kapacitása : kapaciteta kadi : <b>Капацитет на корпуса :</b></p>	27 L
--	---	--	------

	<p>Diamètre tuyau : Tube diameter : Schlauchdurchmesser : Diámetro tubo : Diámetro tubo : Diámetro do tubo : Diameter van de buis : Διάμετρο σωλήνα : Średnica przewodu : Putken halkaisija : Rördiameter :</p>	<p>rørdiameter : diametru furtun : <b>диаметр трубы</b> Boru çapı : průměr trubky : priemer hadice : קוטר צינור قطر الأنبوب. a cső átmérője : <b>premer cevi</b> <b>Диаметър на тръбата :</b></p>	Ø 38 mm
---	---	---	---------

PRO NET70B

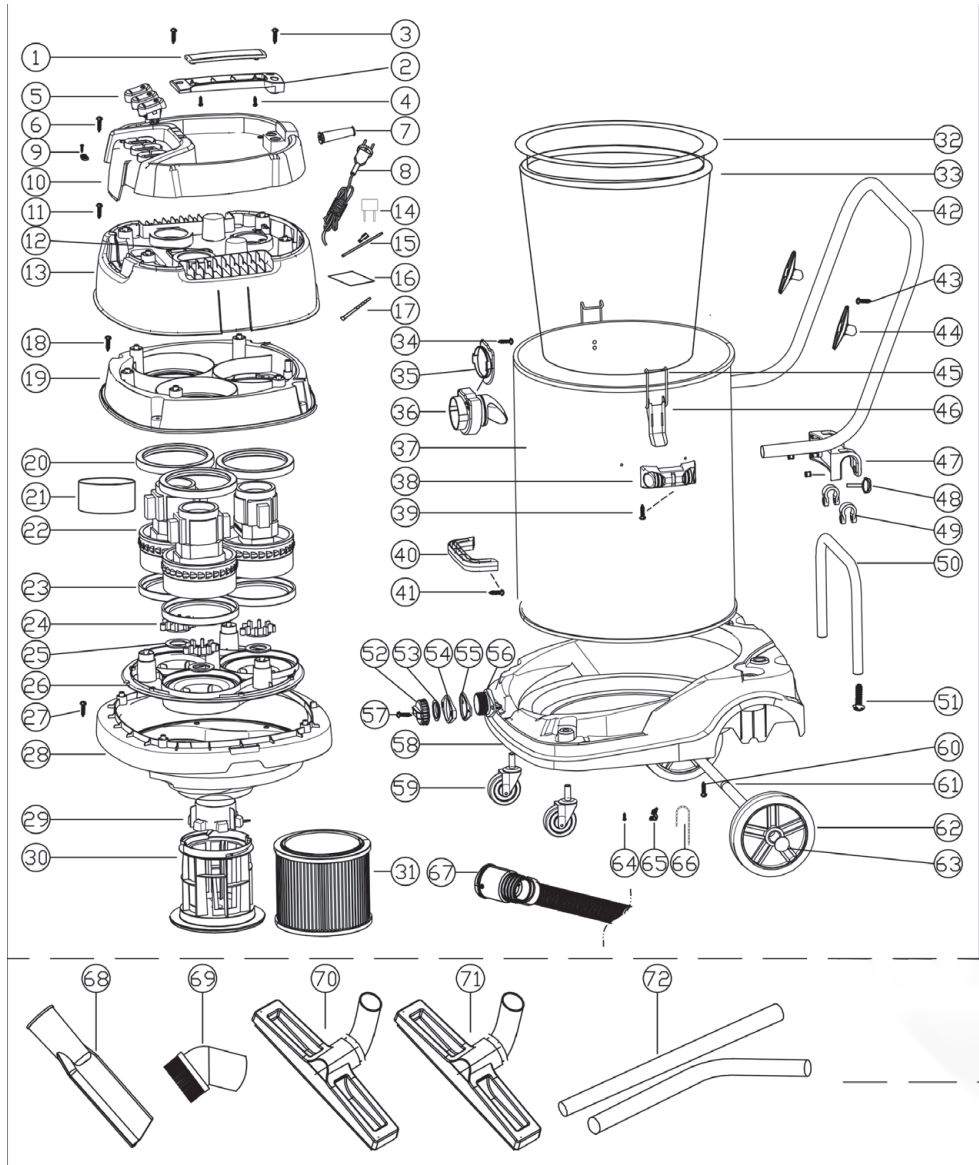

DECLARATION DE CONFORMITE  
VERKLARING VAN OVEREENSTEMMING  
DECLARACION DE CONFORMIDAD  
DICHIARAZIONE DI CONFORMITA  
KONFORMITÄSERKLÄRUNG  
DECLARATION CONFORMITY  
DECLARAÇÃO DE CONFORMIDADE  
DEKLARACJA ZGODNOSCI Z NORMAMI  
OM ÖVERENSSTÄMMEELSE  
VAATIMUSTENMUKAISUUSVAKUUTUS  
OVERENSSTEMMELSESERKLÆRING  
ΔΗΛΩΣΗ ΣΥΜΜΟΡΦΩΣΗΣ

DECLARAȚIE DE CONFORMITATE  
VYHLÁSENIE ZHODY  
Декларация соответствия  
SAMSVARSEKTLÆRING  
Uygunluk beyanı  
التصريح بالامتثال  
PROHLÁŠENÍ SHODY  
EGYZŐSÉGI NYILATKOZAT  
Декларация за съответствие с нормите  
IZJAVA O SKLADNOSTI  
DEKLARACIJA  
ATITIKTIES DEKLARACIJA  
KINNITUS  
IZJAVA O SUKLADNOSTI

Le soussigné,  
Ondergetekende,  
Der Unterzeichner,  
O abaixo assinado,  
Undertecknad,  
Долуподписаният  
Undertegnede  
Subsemnatul,  
Я, нижеподписавшийся,  
Imzalayan,  
Niže podepsány,  
Tollau pasirasęs

Déclare par la présente que,  
Verklaart hiermede dat,  
Erklärt hiermit daß,  
Declara pela presente que,  
Forklarar hermedt att  
Заявляя с настоящето  
erklærer hermed, at  
Declar prin prezenta că,  
настоящим подтверждаю, что  
Mevcut belgeyle beyan ediliyor ki,  
tımto prohlasuje, że,  
Pareiskia, kad,

Personne autorisée à constituer  
le dossier technique :  
Christophe HUREL



FAR GROUP EUROPE  
192, Avenue Yves Farge  
37700 St. Pierre-des-Corps  
FRANCE

El suscrito,  
Il sottoscritto,  
The undersigned,  
Ninej podpisany  
Allekirjoittanut,  
Ο ΚΑΤΩΘΙ ΥΠΟΓΡΑΦΗΜΕΝΟΣ,  
Nizšie podpisany  
Undertegnede,  
الذوقع اندازاه  
Alulírott,  
Podpisani,  
Apakša parakstijies  
allakirjutanu  
Dolje potpisani,

Declara por la presente, que,  
Dichiare che,  
Declares that,  
Oświadczam niniejszym, że  
Ilmoittetaan täten että,  
ΔΙΑ ΤΟΥ ΠΑΡΟΝΤΟΣ ΔΗΛΩΝΕΙ ΟΤΙ,  
týmto vyhlasuje, že  
Erklærer herved at,  
يصرح استنادا على ذلك  
kijelentem, hogy a készülék Izjavlja da,  
Pareiskia, kad,  
Ar šo apliecinā, ka,  
Kinnitab, et  
izjavljuje u ovom dokumentu da je

Aspirateur Industriel / Industrial vacuum cleaner / Industriestaubsauger / Aspirador Industrial / Aspiratore Industriale / Aspirador Industrial / Industriële stofzuiger / Βιομηχανική ηλεκτρική σκούπα /  
Odkurzacz przemysowy / Teollisuuskäyttöön tarkoitettu polynimuri / Industriell sugapparat / Комбинирана промишлена пракоумкена за прах и вода / Industristøvsuger til vand og støv /  
Aspirator industrial apă și praf / Промышленный уловитель воды и пыли / Su ve toz sınai aspiratörü / Průmyslový odsavač vody a prachu /  
Priemyselny odsavač vody a vzduchu / زين التعميل / زوم سويج / Ipari szelész porszívó / Industrijski sisalnik za suho in mokro sesanje /  
Tööstuslik veeja tolmuimeja / Pramoininis plaunamas dulkių siurblys / Rūpnieciskais un putekļu putekšsūcējs

## code

FARTOOLS / 101256 / PRO NET70B / JN601-70L-3000

**Est conforme et satisfait aux directives et normes CE,**  
In overeenstemming is met en Voldoet aan EG richtlijnen,  
Den folgenden EU-Bestimmungen entspricht,  
Respeita e está em conformidade com as normas CE,  
Överensstämmer med och uppfyller EG-standarder,  
Съответства и отговаря европейските норми  
Er i overensstemmelse med og overholder EU standarderne  
Este conform și satisfacă normele CE  
полностью соответствует и удовлетворяет  
требованиям стандартов ЕС  
CE şartlara uygundur,  
odpovídá normám ES.  
Atitinka ir atitinka EB direktyvas ir standartus,

Cumple con la directivas de la CE,  
È conforme alle direttive CEE,  
Complies with the EEC directives and standards,  
Odpowiada normom UE,  
Täyttää EU-vaatimukset,  
ΣΥΜΜΟΡΦΩΝΕΤΑΙ ΚΑΙ ΙΚΑΝΟΠΟΙΕΙ ΤΙΣ ΟΔΗΓΙΕΣ ΚΑΙ ΤΑ ΠΡΟΤΥΠΑ CE,  
zodpovedá normám ES.  
Samsvar med og tilfredsstiller CE-direktiver og standarder,  
بمان الامتثال و يلقى معايير و مواصفات الدول الأوروبية  
kielegíti a CE szabványok előírásait.  
Je v skladu z in izpolnjuje norme Evropske skupnosti.  
Atbilst un atbilst EK direktīvas un standartus.  
Vastab ja vastab EU direktīvidele ja standartitele,  
Sukladan i ispunjava direktive i standarde CE,

2014/30/EU MD :2006/42/EC  
2011/65/EU 2015/863/EU 2014/35/EU

EN62233:2008  
EN60335-2-2:2010+A11:2012+A1:2013  
EN60335-1:2012+A11:2014+A13:2017+A1:2019+A2:2019  
+A14:2019+A15:2021  
ENIEC55014-1:2021  
ENIEC55014-2:2021  
ENIEC61000-3-2:2019+A1:2021  
EN61000-3-3:2013+A1:2019+A2:2021

Christophe HUREL,  
Président Directeur Général  
12/10/2023  
Fait à St. Pierre-des-Corps





## GARANTIE - WARRANTY



### FR. GARANTIE

Cet outil est garanti contractuellement contre tout vice de construction et de matière, à compter de la date de vente à l'utilisateur et sur simple présentation du ticket de caisse. La garantie consiste à remplacer les parties défectueuses. Cette garantie n'est pas applicable en cas d'exploitation non conforme aux normes de l'appareil, ni en cas de dommages causés par des interventions non autorisées ou par négligence de la part de l'acheteur. La garantie ne s'applique pas sur les dommages causés par une défaillance de l'outil.

### DE. GARANTIE

Die Garantiezeit für dieses Gerät in Bezug auf Konstruktions- und Materialfehler beträgt lt. Vertrag bei Vorlage des Kassensbons. Die Garantieleistung besteht im Ersatz schadhafter Teile. Die Garantie erlischt bei einem Einsatz des Geräts, der nicht normentsprechend ist, bei Schäden, die auf unsachgemäße Eingriffe zurückzuführen sind bzw. bei Nachlässigkeit seitens des Käufers. Die Garantie erstreckt sich nicht auf Schäden, die auf Fehlfunktionen des Geräts zurückzuführen sind.

### IT. GARANZIA

Quest' attrezzo è garantito per contratto contro qualsiasi difetto di costruzione e di materia, a partire dalla data di vendita all' utente e su semplice presentazione dello scontrino. La garanzia consiste nel sostituire le parti difettose. Questa garanzia non è applicabile in caso di sfruttamento non conforme alle norme dell' apparecchio, né in caso di danni causati da interventi non autorizzati o da negligenza da parte dell' acquirente. La garanzia non si applica ai danni causati da un' avaria dell' attrezzo.

### EN. GARANTEE

This tool is guaranteed, in writing, against any defect in manufacture or parts from the date of sale, upon simple presentation of the sales slip. The guarantee is limited to the replacement of faulty parts. This guarantee is not applicable in the event of usage which is not conform with the intended usage of the apparatus, nor in the event of damage caused by unauthorised servicing or negligence on behalf of the purchaser. This guarantee does not apply to any damage caused by the failure of this tool.

### ES. GARANTIA

Esta herramienta se garantiza contractualmente contra todo defecto de construcción y materia, a partir de la fecha de venta a l' usuario y sobre simple presentación del recibo de caja. La garantía

consiste en sustituir a las partes defectuosas. Esta garantía no es aplicable en caso de explotación no conforme a las normas del aparato, ni en caso de daños causados por intervenciones no autorizadas o por negligencia por parte del comprador. La garantía no se aplica sobre los daños causados por un fallo del herramienta.

### NL. GARANTIE

Dit gereedschap heeft een garantie tegen constructiefouten en materiaaldefecten, die geldig is vanaf de aankoopdatum door de gebruiker, op vertoning van de kassabon. De garantie betreft de vervanging van de defecte onderdelen. Deze garantie is niet van toepassing indien het apparaat niet volgens de normen gebruikt is, noch in geval van schade veroorzaakt door oneigenlijk gebruik of nalatigheid van de koper. De garantie is niet van toepassing op schade voortvloeiend uit een defect van het gereedschap.

### PT. GARANTIA

Esta ferramenta tem uma garantia contratual contra qualquer defeito de construção e de material, a partir da data de venda ao utilizador e sobre simples apresentação do talão da caixa.. A garantia consiste em substituir as partes defeituosas. Esta garantia não é aplicável no caso de exploração não conforme às normas do aparelho, nem em caso de danos causados pelas intervenções não autorizadas ou por negligência da parte do comprador. A garantia não se aplica para os danos causados por uma falha da ferramenta.

### EL. Εγγύηση

Το εργαλείο αυτ'ο φέρει συμβατικ'η εγγύηση για οΠοιούδ'ηΠοτε ελ'αττωμα κατασκευής αΠ'ο την ημερομηνία Π'ώλησης, στο χρ'ηστη, με αΠλ'η Προσκόμιση της αΠ'ο'οεισής αγοράς. Η εγγύηση αΠοτελείται ατ'ο την αντικατ'ασταση των ελαττωματικ'ων τμημ'ατων. Η Παρο'υσα εγγύηση σεν εφαρμ'οζεται σε Περί'ωση χρ'ησης μη σύμφωνής, με τα Προ'οτυπα της συσκευής, η σε Περί'πτωση ζημιάς Που Προκλ'ηθηκε αΠ'ο μη εγκεκριμ'ενη επ'εμβαση 'η αΠ'ο αμ'ελεα του αγοραστ'η. Η εγγύηση 'οεν εφαρμ'οζεται στις ζημιάς Που Προκαλο'υνται αΠ'ο βλ'αθη του εργαλειου Σταυρο'ι κενο'υ Διαστημιο - Παρ'εμβουμια

### PL. GWARANCJA

Narzędzie jest objęte gwarancją na wszelkie wady konstrukcyjne i materiałowe, licząc od daty sprzedaży u użytkownika i po okazaniu paragonu kasowego. Gwarancja obejmuje wymianę części wybrakowanych. Gwarancja nie, znajduję zastosowania w przypadku użytkowania niezgodnego z normami urządzenia, ani w przypadku szkód spowodowanych działaniami

niedozwolonymi lub zaniedbaniami ze strony nabywcy. Gwarancją nie obejmuje szkód powstałych z powodu upadku urządzenia.

### SV. GARANTI

Detta verktyg har en avtalsenlig garanti mot konstruktions och materiafel, från och med tidpunkten för användarens inköp och genom uppvisning av kassavittot. Garantin består i att ersätta de bristfälliga delarna. Denna garanti gäller inte om användningen inte motsvarar apparatens standarder, inte heller vid skador som orsakas av ej tillåtna ingrepp eller på grund av köparens vårdslöshet. Garantin gäller inte förskador som orsakats av att verktyget fungerat bristfälligt.

### FI. TAKUU

Tämän laitteen takuu on voimassa sopimuskennekäisesti kattaa kaikki rakenne- ja materiaaliiviat lukien ostopäivästä kassakuitista vastaan. Takuu sisältää viallisten osien korvaamisen. Takuu ei korvaa ohjeidenvastaista käyttöä eikä valtuuttamattomien henkilöiden käsitteilyä tai ostajan huolimattomuudesta aiheutuneita vahinkoja. Takuu ei vastaa myöskään toimintahäiriöistä aiheutuneita vahinkoja.

### BU. Гаранция

Този инструмент е под договорна гаранция срещу всякакъв дефект в изработката и използваните материали, считано от датата на продажба на потребителя и само срещу представяне на касовата бележка. Гаранционното обслужване се състои в замяна на дефектните части. Настоящата гаранция не е валидна когато апаратът се използва по начин, несъответстващ на стандарта за работа с него, както и в случай на щети, нанесени от неоторизирани лица, или вследствие на проявена небрежност от страна потребителя. Гаранцията не покрива щети, произтекли вследствие на техническа неизправност на апарата.

### DA. GARANTI

Dele værktøj er dækket af en garanti-kontrakt for konstruktions- og materialefejl, som gælder fra købsdatoen ved visning af kassebonen. Garantien består i at udskifte de defekte dele. Garantien dækker ikke fejl opstået som følge af anvendelse, som ikke overholder standarderne for apparatet, eller skader opstået ved ikke autoriserede indgreb eller sløshed fra brugerens side. Garantien dækker ikke skader opstået, fordi værktøjet har svigtet.

## SERVICE APRÈS VENTE - AFTER SALE SERVICE

FARGROUP EUROPE - 192, Avenue Yves Farge - 37700 St. Pierre-des-Corps - FRANCE

fargroup@fargroup.net

## GARANTIE - WARRANTY



### RO. GARANTIE

Acest aparat este garantat din punct de vedere contractual împotriva tuturor viciilor de construcție și de material, începând de la data vânzării lui către utilizator și la simpla prezentare a bonului de casă. Garanția constă în înlocuirea componentelor defecte. Această garanție nu se aplică în cazul exploatării în alt mod decât cel recomandat de normele aparatului și nici în caz de stricăciuni provocate de intervenții neautorizate sau prin neglijența cumpărătorului. Garanția nu se aplică asupra pagubelor cauzate de o defectare a aparatului.

### RU. ГАРАНТИЯ

Данное изделие обладает имеющей силу контракта гарантией, покрывающей все возможные дефекты изготовления и материала. Гарантия вступает в силу с даты продажи изделия пользователю, для этого достаточно сохранить и предъявить полученный в кассе чек. Гарантия обязывает изготовителя заменить дефектные части изделия. В случае не соответствующего нормам использования изделия, не санкционированного демонтажа или ремонта или небрежного обращения действие гарантии прекращается. Гарантия не покрывает ущерба, возникшего в результате соев в работе изделия.

### TU. GARANTI

Bu araç, satış tarihinden itibaren, kullanıcıların sadece vezne alıncısını sunmasıyla tüm üretim ve malzeme hatasına karşı garantilidir. Garanti eksik olan kısımları değiştirir ve değiştirir. Bu garanti aracın şartlarına uygun olmayan işleme durumunda, izin verilmeyen kullanımlardan kaynaklanan hasarlarda veya alıcının işteği durumunda uygulanmaz. Garanti malzemenin bir eksikliğinden meydana gelen bir zararda uygulanmaz.

### CS. ZÁRUKA

Pro tento nástroj platí smluvní záruka na všechny výrobní a materiálové vady od data prodeje uživateli a na základě předložení pokladního bloku. Záruka spočívá ve výměně vadných částí. Iato záruka neplatí v případě použití přístroje, které neodpovídá normám, ani v případě škod způsobených nepovolenými zásahy nebo nedbalostí ze strany kupujícího. Záruka se nevztahuje na škody způsobené závadou nástroje.

### SK. ZÁRUKA

Pre tento nástroj platí zmluvná záruka na všetky výrobné a materiálové chyby od dátumu predaja užívateľovi a na základe predloženia pokladničného

bloku. Záruka spočívá vo výmene chybných častí. Táto záruka neplatí v prípade použitia prístroja, ktoré nezodpovedá normám, ani v prípade škôd spôsobených nepovolenými zásahmi alebo nedbalosťou zo strany kupujúceho. Záruka sa nevzťahuje na škody spôsobené poruchou nástroja

### HE. אחריות

חשבונית קופה. האחריות-משמעה מיום המכירה למשתמש עם הצגת מפני כל ליקוי בייצור או בחומר, החל הי עככלי זה חלה אחריות לפי חוזה נה שנגרם על ידי התערבות תללל שאינו מתאים לתקנים ובמקרה של אינה חלה במקרה של שימוש במכשיר החלפה תחלקם הלקויים אחריות זו חלה על נה שנגרם על ידי תקלה בכלי רשלנות מאת הקונה. האחריות בינה מכות או על ידי

### AR. الضمان

على مجرد تقديم بطاقة الشراء يتغل في تاريخ البيع الذي المستعمل وبناءا في التصدي عوفي الجواد. اختيارا من الخ ده مصنفة تذاذي. من أي عيب في حالة تعرضه لتلفات إن فده غير المطابق لمعايير الجهاد. ولا وأبلا للتطبيق في حالة الاستخدام الأجزاء العاطلة لا يكون هذا الضمان الناتج عن خلل الضمان فباي استدال المستخدم لا ينطبق الضمان على الضرر غير مخرصة أو في حالة الأمل من قبل تاتج عن عطليات تدخل

### HU. GARANCIA

Erre a szerszámra szerződéses garanciát vállalunk bármilyen gyártási és anyaghiba felmerülése esetére, a fogyasztó részére történt eladás napjától számítva, a pénztári blokk egyszerű felmutatása ellenében. A garancia a hibás alkatrészek cseréjére terjed ki. Ez a garancia nem érvényes, ha a készüléket nem rendeltetésszerűen használták, sem illetéktelen beavatkozások, vagy a vásárló hanyagsága okozta károk esetén. A garancia nem fedezi azokat a károkat, melyeket a szerszám hibás működése okozott.

### SL. GARANCIJA

To orodje je z garancijsko pogodbo zaščiteno proti vsem napakam v izdelavi in v sestavnem materialu od datuma prodaje naprej in ta velja ob predložitvi blagajniškega računa. Garancija velja za zamenjavno delov z napako. Ta garancija ne velja za uporabo orodja, ki ni v skladu z normami, predpisanimi za omenjeno orodje in za primere okvar, ki nastanejo zaradi nedovoljenih posegov na orodju ali zaradi malomarnega rokovanja kupca. Garancija ne velja za škodo, ki jo lahko povzroči okvara orodja.

### ET. GARANTII

See tööriist kuulub lepingu järgi garantiiremonti arvestades alates müümise päevast ja kasutajate alusel kasutatavale kõigi konstruktsiooni- ja materjalivigade puhul. Garantii seisneb defektsete osade väljavahetamises. See garantii ei kehti aparadi normide ebatavalise eiramise puhul ega ostja poolt keelatud viisil kasutamisest või hooletusjätmisest

tulenevate kahjude korral. Garantii ei kehti seadme defektidest põhjustatud kahjude puhul

### IV. GARANTIJA

Sis prietaisas yra užtikrinamas kaip itin geros kokybės, nuo jo pardavimo datos iki jo panaudojimo, ir jam yra suteikiama garantinis talonas. Garantijos metu galima pakeisti atsiradusius trumplaikius gedimus. Si garantija netaikoma esant netinkamam naudojimui ar nesilaikant reikiam šio aparato vartojimo instrukcijų, tai pat pačiam pirkejiui jį sugadinus. Garantija taip pat netaikoma, prietaisą naudojant ne pagal paskirtį ir jį apgadinus

### IT. GARANTIA

Sim darbarikam ir ligumā noteikta garantija visiem defektiem, kas saistās ar konstrukciju un materiālu, sākot ar pārdošanas datumu, kad mašīnu pārdo lietotājam un vienkāši uzrādāt kases čeku. Garantija iekļauj bojāto daļu nomainu. Šī garantija nav derīga, ja aparātš nav lietots saskaņā ar drošības noteikumiem, ne gadījumos, ja bojājumi radušies nesankcionētas iekaujšanas gadījumā vai arī pircēja nolaidības dēļ. Garantija nav derīga, ja bojājumi radušies darbarika defekta dēļ

### HR. JAMSTVO

Ovaj alat ima ugovorno jamstvo u slučaju bilo kakvih nedostataka u konstrukciji i materijalu, od datuma prodaje korisniku uz jednostavno predocenje računa. Jamstvo se sastoji u zamjeni neispravnih dijelova. Ovo se jamstvo ne primjenjuje u slučaju uporabe i eksploatacije koja nije sukladna standardima uređaja, niti u slučaju štete uzrokovane neovlaštenim intervencijama ili nemanom kupca. Jamstvo se ne primjenjuje na štetu uzrokovanu nekim nedostatkom alata.

## SERVICE APRÈS VENTE - AFTER SALE SERVICE

FARGROUP EUROPE - 192, Avenue Yves Farge - 37700 St. Pierre-des-Corps - FRANCE

fargroup@fargroup.net



## FAR GROUP EUROPE

Une société du groupe **SIGMA**

192, Avenue Yves Farge  
37700 St. Pierre-des-Corps  
FRANCE

**[fartools.com](http://fartools.com)**

