

FAR TOOLS®

- FR** Aiguisseur multifonctions (Notice originale)
- EN** Multifunctional sharpener (Original manual translation)
- DE** MultifunktionsSchärfer (Übersetzung aus dem Original-Anleitung)
- ES** Afilador multifuncional (Traducción del manual de instrucciones originale)
- IT** Temperamatite multifunzione (Traduzione dell'avvertenza originale)
- PT** Afiador multifuncional (Tradução do livro de instruções original)
- NL** Multifunctionele puntenslijper (Vertaling van de originele instructies)
- EL** Πολυλειτουργικό Ξύστρα (Μετάφραση από τις πρωτότυπες οδηγίες)
- PL** Wielofunkcyjna temperówka (Tłumaczenie z oryginalnej instrukcji)
- FI** Monitoiminen teroitin (Käännös alkuperäisestä ohjeet)
- SV** Multifunktionell vässare (Översättning från originalinstruktioner)
- BU** Многофункционална острилка (Превод на оригиналната инструкция)
- DA** Multifunktionel slibemaskine (Oversættelse fra oprindelige brugsanvisning)
- RO** Ascutitor multifunctional (Traducere din instrucțiunile originale)
- RU** Многофункциональная точилка (Перевод с оригинальной инструкции)
- TU** Çok fonksiyonlu kalemtıraş (Orijinal talimatlar çeviri)
- CS** Multifunkční ořezávátko (Překlad z originálního návodu)
- SK** Multifunkčné brúsky (Preklad z originálneho návodu)
- HE** בקמ שיטפ (מחדד רב תכליתי)
- AR** ليصلأل تاميلعت فيأظولأ قددعتم ؤاربم
- HU** Többfunkciós hegyező (Fordítás az eredeti utasítások)
- SL** Večnamenski ostenje (Prevod iz izvornih navodil)
- ET** Multifunktsionaalne teritaja (Tõlge originaal juhiseid)
- LV** Daudzfunkcionāls asināmais (Tulkojumā no instrukcijas oriģinālvalodā)
- LT** Daugiafunkcinis galąstuvąs (Vertimas iš originalių instrukcijas)
- HR** Višenamjenski oštrica (Prijevod prema originalne upute)



AFM 65
Professional Machine



© FAR GROUP EUROPE

110173-B-20231219



fartools.com



10 min

MERCI !



Retravailler le conditionnement nous à permis de supprimer tous les emballages issus de produits dérivés d'hydrocarbures, au profit d'un packaging **100 % recyclable**.

>>> Pour en savoir plus, flashez ce code
et retrouvez toutes les informations sur notre site :



Description et repérage des organes de la machine
Description and location of machine parts

A



Contenu du carton
Contents of box

C



Points de collecte sur www.quefairede mesdechets.fr
Privilégiez la réparation ou le don de votre appareil!

Assemblage de la machine
Assembling the machine

D

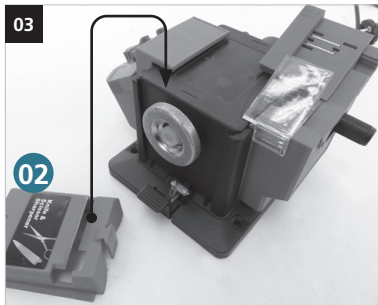
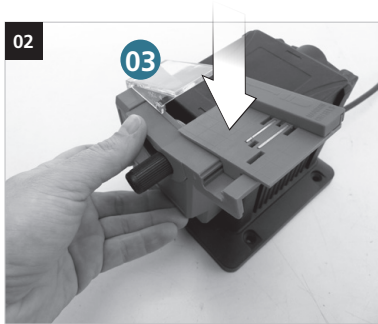
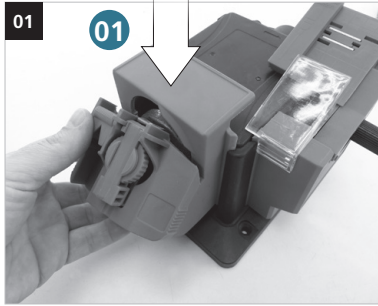

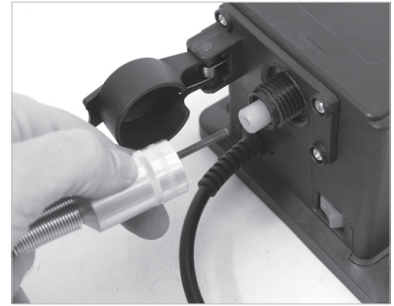
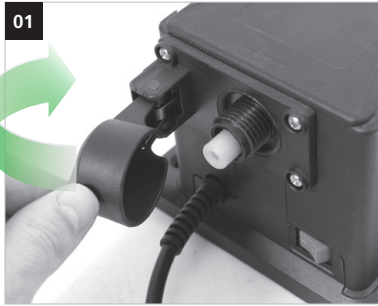

Fonctionnalité de la machine
Functions of the machine

E

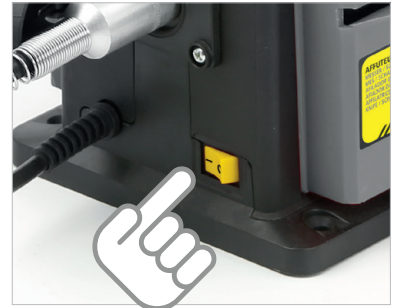
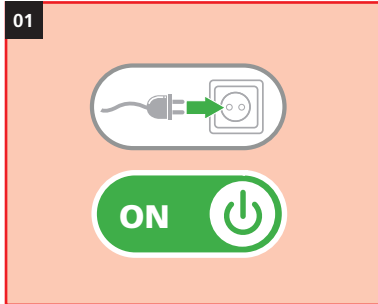

01



03

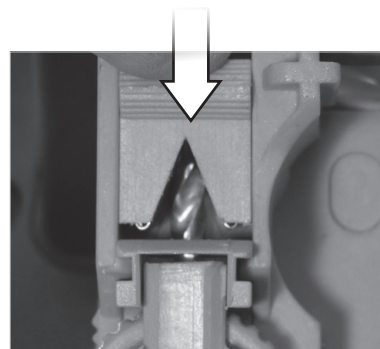
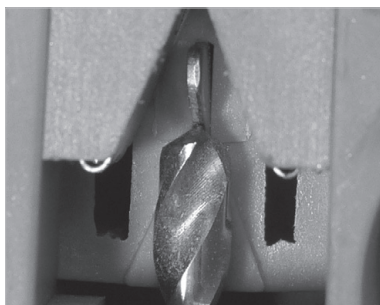
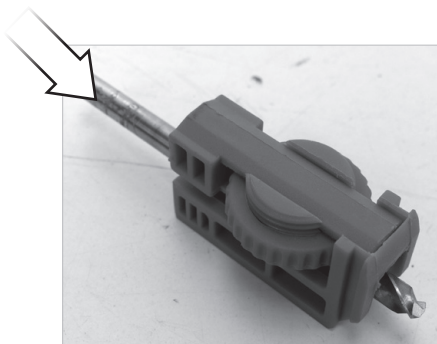
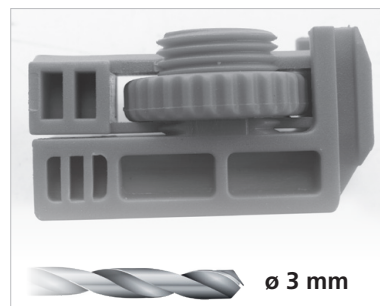
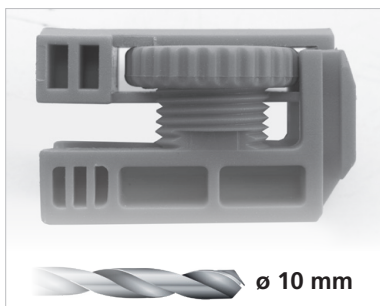
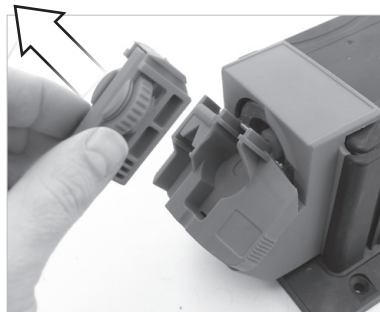

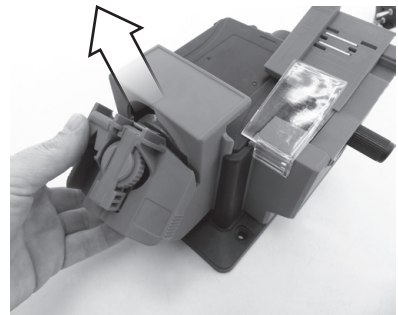
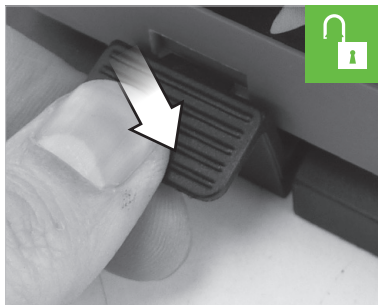
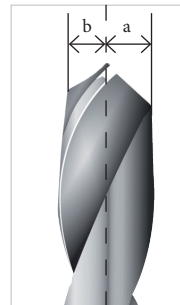
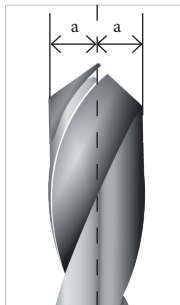
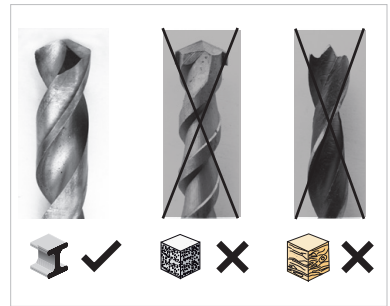
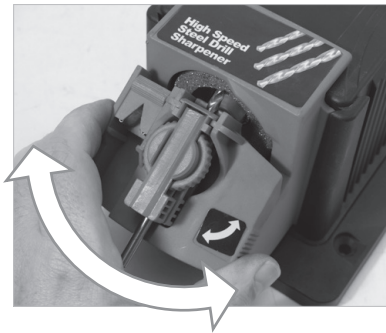
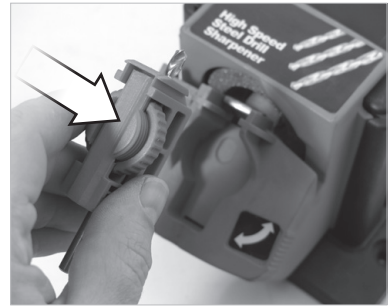
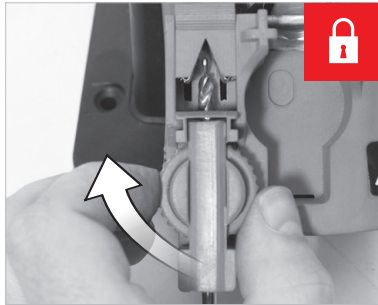

02



04

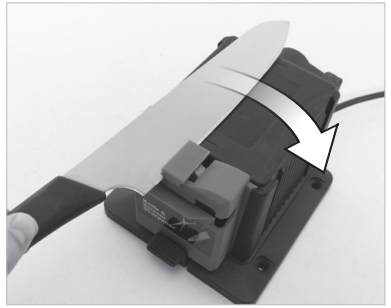
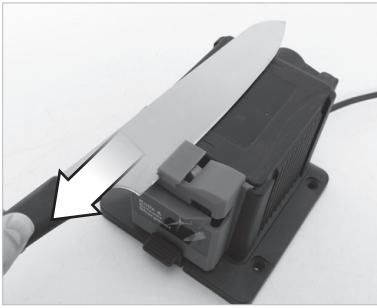
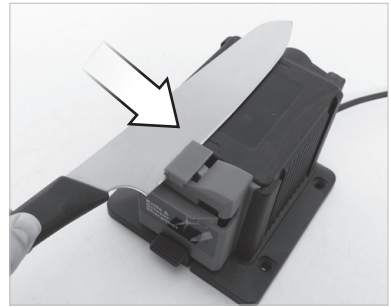
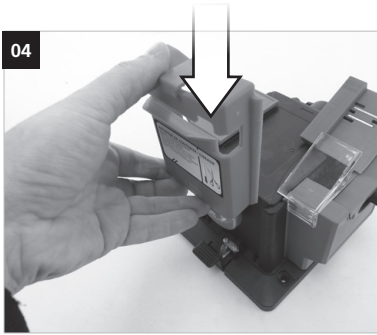

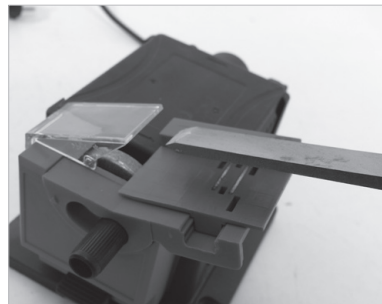
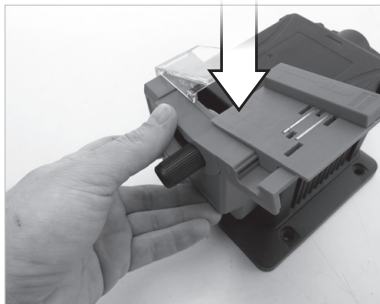

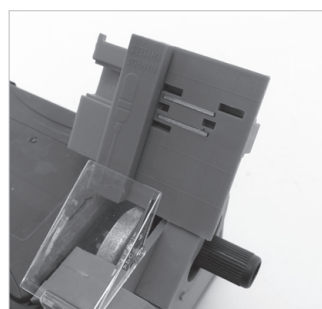
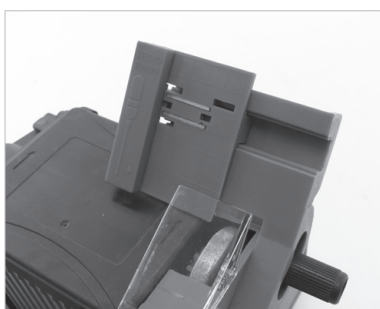
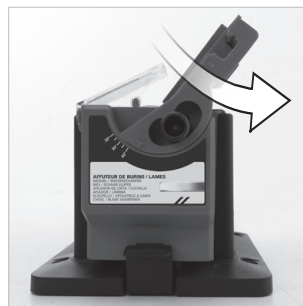

20 °

40 °



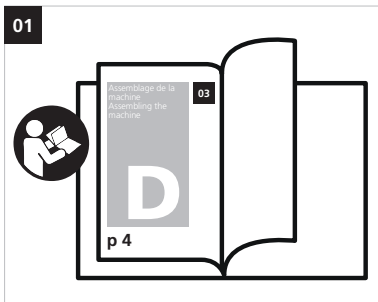

G





	<p>Tension et fréquence assignée: Nominal frequency and power: Spannung und Frequenz: Tensión y frecuencia fijada: Tensione e frequenza assegnata: Tensão e frequência fixa: Aangewezen spanning en frequentie: Όνομαστική τάση και συχνότητα: Napięcie i częstotliwość przydzielona: Jännite ja määrittäytyä taajuus: Angiven spänning och frekvens: Anført spænding og frekvens: Tensiune și frecvență de lucru:</p>	<p>Заданное напряжение и частота: Tahsis gerilimi ve frekans: Stanovené napětí a frekvence: Stanovené napätie a frekvencia: מחמת ותדר מוקצב الغلفية والذبذبة المبرمجة. Névfleges feszültség és frekvencia: Napetost in določena frekvenca: Консумирано напрежение и честота : Määratud pinge ja sagedus Nustatyta įtampa ir dažnis Noteiktais spriegums un frekvence. Napon i nazivna frekvencija:</p>	230 V ~ 50 Hz
---	--	---	----------------------

	<p>Puissance assignée: Nominal power: Leerlaufdrehzahl: Potencia fijada: Potenza assegnata: Potência assinada: Onbelast toerental: Όνομαστική ισχύς : Prędkość na biegu jałowym: Teho: Angiven effekt: Anført styrke: Putere de lucru:</p>	<p>Заданная мощность: Tahsis edilen güç: Stanovený příkon: Predpísaný výkon: כוח מוקצב القدرة المبرمجة Névfleges teljesítmény : Določena jakost: Консумирана мощност: Määratud võimsus. Nustatyta galia Noteiktā jauda Nazivna snaga:</p>	<p>S3 SERVICE INTERMITTENT Répétition de cycles identiques comprenant chacun une période de fonctionnement à la charge constante et une période de repos; on considère que l'intensité de démarrage n'affecte pas l'échauffement du moteur de façon significative. OBSERVATION: ce service peut permettre une puissance utile supérieure à la puissance nominale.</p>	65 W (S3)
---	--	--	---	------------------

	<p>Classe d'isolement : 2 Insulation class : 2 Isolierung klasse : 2 Aislamiento clase :2 Isolamento classe :2 Isolamento classe :2 Isolatīe Klasse : 2 Εργαλειο τάξη : 2 Izolacja Klasy :2 Eristysluokka :2 Isolering Klass :2 Isoleringsklasse 2 Clasă izolație :2</p>	<p>Класс изоляции 2 : Yalıtım derecesi :2 Třída izolace :2 Izolačný systém 2 סוג בידוד 2. قسيّة العزل 2. Szigetelési osztály :2 Razred izolacije :2 Инструмент Клас :2 Isolatsiooniklass 2 Izolācijas rūšis 2 Izolācijas klase 2 Izolacija klasa: 2</p>	X
--	--	--	----------

	<p>Vitesse à vide: No-load speed: Drehzahl unbelastet: Velocidad vacía: Velocità a vuoto: Velocidade no vácuo: Leerlaufdrehzahl: Ταχύτητα στο κενό: Prędkość bez obciążenia: Tyhjäkäyntinopeus Tomgångshastighet: Hastighed i ubelastet tilstand: Viteza în gol:</p>	<p>Скорость вращения на холостом ходу: Boşalma hızı: Rychlost naprázdno: Rýchlost' pri chode naprázdno: מהירות ריק. السرعَة على الفارغ. Üres sebesség: Prosti tek: Скорост на празни обороти: Kiirus tühikäigul Tuščio prietaiso greitis Tukšgaitas ātrums Brzina praznog hoda:</p>	4800 min⁻¹
---	--	--	------------------------------

	<p>Porter des lunettes de sécurité : Wear protective eyewear : Schutzbrille tragen : Llevar puestas gafas protectoras : Portare de gli occhiali di sicurezza : Utilizar óculos de seguridad : Draag een veiligheidsbril : Φορέστε Προστατευτικά γυαλιά : Zakładać okulary ochronne : Käytä suojalaseja : Använd skyddsglasögon : Der skal benyttes sikkerhedsbriller : Purtati ochelari de protectie :</p>	<p>Наденьте защитные очки : Güvenlik gözlükleri takın : Ποζήvejte bezpečnostní brýle : Noste ochranné okuliare : תוהיטב יפקשמ ביכרהל אנ חמל נזפארט וקאי. Viseljen védőszemüveget : Nositi zaščitna očala : Да се използват защитни очила : Kandke kaitseprille Nešioti apsauginius akinius Valkät aizsargbrilles Nositi zaštitne naočale:</p>	X
---	--	---	---

	<p>Porter un masque anti-poussière : Wear a dust mask : Staubschutzmaske tragen : Llevar puesta una careta de protección contra el polvo : Indossare una mascherina anti-polvere : Utilizar uma máscara anti-poeira : Draag een stofmasker : χρήση προστατευτική μάσκα : Zakładać maskę przeciwpyłową Käytä pölysuojust : Bär mask mot damm : Der skal benyttes beskyttelsesmaske mod støv: Purtati mască anti-praf :</p>	<p>Наденьте респиратор : Toza karşı maske takın : Ποζήvejte masku proti prachu : Noste ochrannú masku proti prachu : קבא דגנ הכסמ שובחל אנ ליס קזא ע מפראש ללעגיא. Viseljen porvédő maszkot Nositi zaščitno masko proti prahu: Да се използва защитна маска : Kandke tolmumaski. Dëvëti respiratoriq Valkät aizsarg masku pret putekļiem Nositi masku za zaštitu od prašine:</p>	X
---	---	---	---

	<p>Porter une protection auditive : Wear hearing protective equipment: Gehörschutz tragen: Llevar puesta una protección auditiva: Portare una protezione uditiva: Utilizar uma protecção auditiva: Draag gehoorbeschermers: Φορέστε Προστατευτικά ακουστικά Zakładać słuchawki ochronne Käytä kuulosuojaimia: Bär hörselskydd: Der skal benyttes hørevern: Purtati căști de protectie auz:</p>	<p>наденьте средства звуковой защиты: İşitsel koruma aleti takın: Ποζήvejte ochranu sluchu: Noste ochranné slúchadlá: יש ל הרכיב הגנת שמיעה ליס חודת פרעס אלזשיג Viseljen fülvédőt Nositi zašito ušes: Да се използва слухови защитни средства: Kandke kõrvakaitset Nešioti apsaugā nuo triukšmo Valkät dzirdes aizsarglīdzekli Nositi štitnike protiv buke:</p>	X
--	--	--	---

	<p>Porter des gants : Use rubber gloves : Schutzhandschuhe tragen : Llevar guantes de protección : Indossare i guanti di protezione : Utilizar luvas de protecção : Draag veiligheidshandschoenen : χρήση προστατευτικών γαντιών : Używać rękawic ochronnych : Käytä suojakäsineitä : Använd skyddshandskar : Der skal benyttes handsker : Purtati m̃anuşi :</p>	<p>Наденьте перчатки : Eldiven takın : Noste rukavice : Noste rukavice : תופכ שובלל אנ ליס קפארזאט. Viseljen kesztyű t Nositi rokavice: а се използват предпазни ръкавици : Kandke kindaid Müvëti pirštines Valkät cimdus Nositi zašitne rukavice:</p>	X
---	--	--	---

	<p>Lire les instructions avant usage : Read the instructions before use : Vor Einsatz des Geräts Anweisung lesen : Léase las instrucciones antes de usar : Leggere le istruzioni prima dell'uso : Ler as instruções antes da utilização : Lees voor het gebruik de instructies : Διαβάστε τις οδηγίες χρήσης : Zapoznać się instrukcją przed użyciem : Lue ohjeet ennen käyttöä : Läs anvisningarna före användning : læs instruktionerne før brug Înainte de utilizare, citiți instrucțiunile :</p>	<p>Внимательно прочитайте следующие инструкции : Kullanmadan talimatları okuyunuz : Pozorně si přečtěte následující pokyny : Pred použitím si prečítajte pokyny : זרם חילופי اقرأ التعلیمات قبل الاستخدام használat előtt olvassuk el az utasítást : Pred uporabo preberite ustrezna navodila Прочетете указанията за употреба : Enne kasutamist lugege instruksiooni Prieš naudojimą perskaityti instrukciją izlasīt instrukcijas pirms lietošanas Pročitati upute prije uporabe:</p>	X
---	--	---	---

	<p>Conformité européenne Conforms to EC standards : CE-Konformität : Cumples con las directivas CE : Conforme alle norme CE : Conforme às normas CE : Voldoet aan de EG-normen : Συμφωνο με τα πρότυπα Zgodność z normami CE : EU-standardien mukainen : EU-standardien mukainen : Overholder EU standarderne : Conform cu normele europene:</p>	<p>соответствие европейским стандартам: Avrupa uygunluk : evropská shoda : európska dohoda : התאמה לתקנים האירופיים مطابق للمواصفات الأوروبية. evropska ustreznost : európai megfelelőség : Съответствие с европейските норми : Euroopa Liidu vastavusmärk Europinių normų atitikima Atbilstība Eiropas standartiem Europska sukladnost</p>	X
---	--	---	---

	<p>Danger : Danger : Gefahr : Peligro : Pericolo : Perigo : Gevaar : Κινδύος : Niebezpieczeństwo : Vaara : Fara : Fare : Pericol :</p>	<p>Опасно : Tehlike : Nebezpečí : Nebezpečnost : סכנה. خطر. Veszély : Nevarnost: Опасно : Oht Pavojus Bistamība Opasnost:</p>	X
--	--	---	---

	<p>Poids : Weight : Gewicht : Peso : Peso : Peso : Gewicht : Βάρος : Masa : Paino : Vikt : Vægt : Greutate :</p>	<p>Вес : Ağırlık : Hmotnost : Hmotnosť : משקל الوزن. Súly : Teža : Težina : Raskus Svoris Svars Težina</p>	1,5 kg
---	--	--	--------

 L_{pA}	Niveau de pression acoustique :	Уровень акустического давления. :	60,5 dB (A)
	Acoustic pressure level :	Akustik basınç seviyesi :	
	Schalldruckpegel :	Hladina akustického tlaku :	
	Nível de presión acústica :	Hladina akustického tlaku :	
	Livello di pressione acustica :	רמת לחץ אקוסטי.	
	Nível de pressão acústica :	مستوى الضغط السريعي.	
	Niveau akoestische druk :	A hangnyomás szintje :	
	Σπίθμη Θορύβου :	Nivo akustičnega pritiska:	
	Poziom mocy akustycznej :	Равнище на акустично налягане :	
	Käytä kuulosuojaimia:	Helirõhu niivo	
	Ljudtrycksnivå :	Akustinio spaudimo lygis	
Lydtryk :	Akustiskā spiediena līmenis		
Nível presiune acustică :	Razina zvučnog tlaka:		

 L_{wA}	Niveau de puissance acoustique :	уровень мощности звука :	73,5 dB (A)
	Acoustic power level :	Akustik basınç seviyesi :	
	Schalleistungspegel :	Hladina zvukového výkonu:	
	Nível de potencia acústica :	Hladina zvukového výkonu:	
	Livello di potenza acustica:	רמת כוח אקוסטי.	
	Nível de potência acústica:	مستوى الضجيج.	
	Niveau akoestisch vermogen :	a hangnyomás szintje :	
	Σπίθμη Ονομαστική Θορύβου :	Nivo akustične jakosti :	
	Poziom mocy akustycznej :	Равнище на вибрации :	
	Käytä suojalaseja :	Helivõimsuse niivo	
	Ljudstyrkenivå :	Triukšmo lygis	
Lydstyrke :	Akustiskās jaudas līmenis		
Nível putere acustică :	Razina zvučne snage:		

NIVEAU SONORE D'ÉMISSION : A VIDE

Pression acoustique L_{pA} poste opérateur 60,5 dB
Incertitude 3

Puissance acoustique L_{WA} 73,5 dB
Incertitude 3

Valeurs déterminées suivant le code d'essai de l'annexe B de la norme EN 61029-1 avec emploi des normes de base ISO 11201 et ISO 3744.

Les niveaux de pression acoustique obtenus in situ dépendent:

- Des niveaux réels de la machine considérées, en prenant en compte les incertitudes déclarées;
- Du local et de l'installation de la machine. Préférez une pièce dont l'acoustique est plus feutrée. Evitez les pièces vide à grande résonance. Placez vous auprès d'une fenêtre le cas échéant.
- Des outils montés, des pièces travaillées, des réglages choisis,...

	<p>Soumis à recyclage Subjected to recycling Sujeto a reciclaje Sottoposti a riciclaggio Sujeitos à reciclagem Não deite no lixo : Niet wegwerpen : Μην την πετάτε : Nie wyrzucas : Álā heitā pois luontoon : Batteriet fār inte kastas : Bortkast det ikke: Nu le auncati :</p>	<p>Не выбрасывайте в мусорный ящик Atmayıniz : Nevyhazujte je do bežného odpadu : Neodhadzovat : אין לזרוק סוללות فلا ترمدها ملئذا فسي القمامة. ne mečíte1 Ne odvržite ga/jih vstran : Не го изхвърляйте : Árge visake seda minema : Nemétykíte : Nemest : Podvrqnuto recikliranju</p>	X
---	--	--	---

Recyclage des déchets :

Les outils, accessoires et leur emballages doivent suivre une voie de recyclage adaptée. Conformément aux directives Européenne 2012/19/UE et 2006/66/CE, les composants d'un produit doivent être séparés, collectés, recyclés ou éliminés en conformité avec les réglementations environnementales en vigueur. Les appareils, batteries, piles, huiles, emballages devront être déposés dans les systèmes d'élimination des déchets spéciaux tels que déchetteries. Renseignez-vous auprès de votre commune pour connaître l'organisme le plus proche à même de retraiter ou de collecter ces déchets.

	<p>Recyclable, soumis au tri sélectif Recyclable, subject to recycling Recyclingfähige, unterliegen Recycling Reciclables, sujetos a reciclaje Riciclabili, soggetti a riciclaggio Recicláveis, sujeito à reciclagem Recycleerbare, onderworpen aan recycling Ανακυκλώσιμες συσκευασίες που υπόκεινται σε κύκλωση Opakowanie nadaje się do recyklingu podlegają recyklingu Kierrätettävien pakkausten kohteena kierrätys Återvinningsbara förpackningar omfattas återvinning Рециклиращи се опаковки подлежат на рециклиране Genanvendelig underlagt genbrug</p>	<p>Reciclabile sub rezerva reciclar Повторно опаковка подлежит вторичной переработке Gerí donüşüm Geri donüştürülebilir ambalaj konusu Recyklovateľné podléhajúcí recyklácii Recyklovateľné podliehajúce recykláciiu החמל והחמל הזיראה אשונ رېوېدئلا ھا ېال رېوېدئلا ھا ېال ټاټټلا نېل رېوېدئلا Újrahasznosítható csomagolás alá újrahasznosítás Reciklirati predmet recikliranja Pakendite suhtes ringlussevõtu Pārstrādājams iepakojumus otrreizējai pārstrādei Perdirbamų taikomos perdirbimo Može se reciklirati, podložno selektivnom sortiranju</p>	X
---	---	--	---

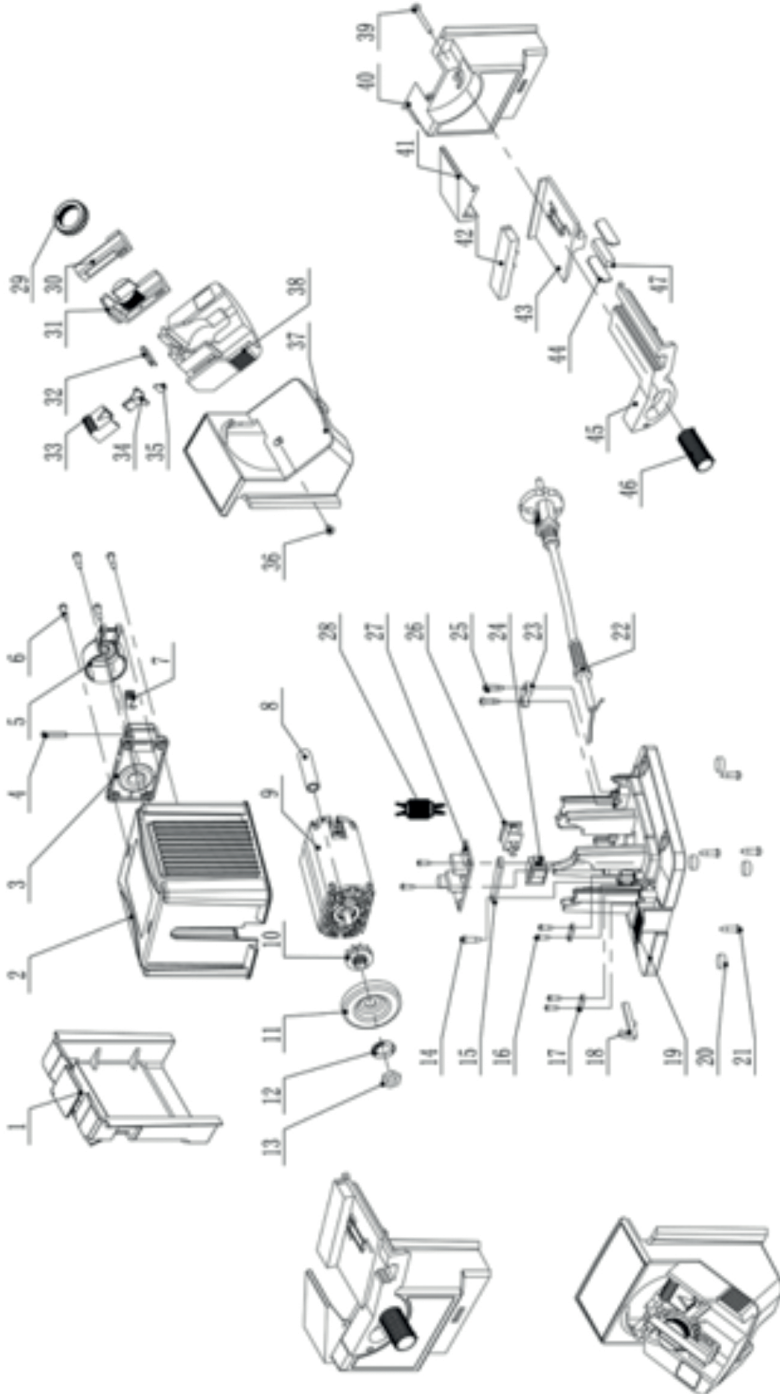

DECLARATION DE CONFORMITE
VERKLARING VAN OVEREENSTEMMING
DECLARACION DE CONFORMIDAD
DICHIARAZIONE DI CONFORMITA
KONFORMITÄSERKLÄRUNG
DECLARATION CONFORMITY
DECLARAÇÃO DE CONFORMIDADE
DEKLARACJA ZGODNOSCI Z NORMAMI
OM ÖVERENSSTÄMMELSE
VAATIMUSTENMUKAISUUSVAKUUTUS
OVERENSSTEMMELSESERKLÆRING
Δήλωση συμμόρφωσης/συμμόρφωση

DECLARAȚIE DE CONFORMITATE
VYHLÁSENIE ZHODY
Декларация соответствия
תצהיר תואמת
Uygunluk beyanı
التصريح بالمتطابق
PROHLÁŠENÍ SHODY
EGYZEZŐSÉGI NYILATKOZAT
Декларация за съответствие с нормите
IZJAVA O SKLADNOSTI
DEKLARACIJA
ΑΤΤΗΚΤΙΚΕΣ DEKLARACIJA
KINNITUS
IZJAVA O SUKLADNOSTI

Le soussigné,
Ondergetekende,
Der Unterzeichner,
O abaixo assinado,
Undertecknad,
Долуподписаният
Undertegnede
Subsemnatul,
Я, нижеподписавшийся,
Imzalayan,
Niže podepsany,
Toliau pasirašęs

Déclare par la présente que,
Verklaart hiermede dat,
Erklärt hiermit daß,
Declara pela presente que,
Förklarar härmed att
Заявляя с настоящето
erklærer hermed, at
Declar prin prezenta că,
настоящим подтверждаю, что
Mevcut belgeyle beyan ediliyor ki,
tımto proħlaşuje, že,
Pareiškia, kad,

Personne autorisée à constituer
le dossier technique :
Christophe HUREL



FAR GROUP EUROPE
192, Avenue Yves Farge
37700 St. Pierre-des-Corps
FRANCE

El suscrito,
Il sottoscritto,
The undersigned,
Ninej podpisany
Allekirjoittanut,
Ουπτοεγραμμένος
Nižšie podpisany
מצהיר מטה,
الھوقق عن أدناه
Alulírott,
Podpisani,
Apakšā parakstijies
allaķirjutanu
Dolje potpisani,

Declara por la presente, que,
Dichiare che,
Declares that,
Oöwiadczam niniejszym, że
Ilmoitetaan täten että,
Δηλώνω με υπεύθυνη
týmto vyhlásuje, že
מצהיר בה כן
يصرح استناداً على ذلك
Pareiškia, kad,
Ar šo apliecinā, ka,
Kinnitab, et
Izjavljuje u ovom dokumentu da je

Aiguiseur multifonctions / Multifunctional sharpener / Multifunktionsschärfer / Afilador multifuncional / Temperamatite multifunzone / Afilador multifuncional / Multifunctionele puntenslijper / Πολυλειτουργικό ξυστρά / Wielofunkcyjna temperówka / Monitoiminen teroitin / Multifunktionell vässare / Многофункционална острилка / Multifunktionel slibmaskine / Ascultitor multifuncional / Многофункционална точилка / Çok fonksiyonlu kalemtıraş / Çok fonksiyonlu kalemtıraş / Multifunkční ořezávkto / Multifunkčné brúsky / تيدكبر بر دودم / تيدكبر بر دودم / Többfunkciós hegyező / Többfunkciós hegyező / Večnamenski osterenje / Multifunktsionaalne teritaja / Daudzfunkcionāls asināmais / Daugiafunkcinis galąstuvus / Daugiafunkcinis galąstuvus / Višenamjenski oštrica

code

FARTOOLS / 110173 / AFM 65 / 2004 C

Est conforme et satisfait aux directives et normes CE,
In overeenstemming is met en Voldoet aan EG richtlijnen,
Den folgenden EU-Bestimmungen entspricht,
Respeita e está em conformidade com as normas CE,
Överensstämmer med och uppfyller EG-standarder,
Съответства и отговаря европейските норми
Er i overensstemmelse med og overholder EU standarderne
Este conform și satisface normele CE
полностью соответствует и удовлетворяет
требованиям стандартов ЕС
CE şartlara uygundur,
odpovídá normám ES.
Atitinka ir atitinka EB direktyvas ir standartus,

Cumple con la directivas de la CE,
E conforme alle direttive CEE,
Complies with the EEC directives and standards,
Odpowiada normom UE,
Täyttää EU-vaatimukset,
Είναι συμμόρφωτο και ανταποκρίνεται στα Πρότυπα CE
מתימים ועונה לתקני CE
بأن الجهاز يتطابق و يلبى متطلبات جميع الدول الأوروبية
kielgēti a CE szabványok előírásait.
Je v skladu z in izpolnjuje norme Evropske skupnosti.
Atbilst un atbilst EK direktīvas un standartus,
Vastab ja vastab EŪ direktīvi dele ja standarde dele,
Sukladan i ispunjava direktive i standarde CE,

2014/30/EU 2006/42/EC
2011/65/EU 2015/863/EU

EN61029-1:2009/A11:2010
ENISO 12100:2010
EN61000-3-2:2014
EN61000-3-3:2013
EN55014-2:2015
EN55014-1:2017

Christophe HUREL,
Président Directeur Général
11/03/2020
Fait à St. Pierre-des-Corps

GARANTIE - WARRANTY



FR. GARANTIE

Cet outil est garanti contractuellement contre tout vice de construction et de matière, à compter de la date de vente à l'utilisateur et sur simple présentation du ticket de caisse. La garantie consiste à remplacer les parties défectueuses. Cette garantie n'est pas applicable en cas d'exploitation non conforme aux normes de l'appareil, ni en cas de dommages causés par des interventions non autorisées ou par négligence de la part de l'acheteur. La garantie ne s'applique pas sur les dommages causés par une défaillance de l'outil.

DE. GARANTIE

Die Garantiezeit für dieses Gerät in Bezug auf Konstruktions- und Materialfehler beträgt lt. Vertrag bei Vorlage des Kassensbons. Die Garantieleistung besteht im Ersatz schadhafter Teile. Die Garantie erlischt bei einem Einsatz des Geräts, der nicht normentsprechend ist, bei Schäden, die auf unsachgemäße Eingriffe zurückzuführen sind bzw. bei Nachlässigkeit seitens des Käufers. Die Garantie erstreckt sich nicht auf Schäden, die auf Fehlfunktionen des Geräts zurückzuführen sind.

IT. GARANZIA

Quest' attrezzo è garantito per contratto contro qualsiasi difetto di costruzione e di materia, a partire dalla data di vendita all' utente e su semplice presentazione dello scontrino. La garanzia consiste nel sostituire le parti difettose. Questa garanzia non è applicabile in caso di sfruttamento non conforme alle norme dell' apparecchio, né in caso di danni causati da interventi non autorizzati o da negligenza da parte dell' acquirente. La garanzia non si applica ai danni causati da un' avaria dell' attrezzo.

EN. GARANTEE

This tool is guaranteed, in writing, against any defect in manufacture or parts from the date of sale, upon simple presentation of the sales slip. The guarantee is limited to the replacement of faulty parts. This guarantee is not applicable in the event of usage which is not conform with the intended usage of the apparatus, nor in the event of damage caused by unauthorised servicing or negligence on behalf of the purchaser. This guarantee does not apply to any damage caused by the failure of this tool.

ES. GARANTIA

Esta herramienta se garantiza contractualmente contra todo defecto de construcción y materia, a partir de la fecha de venta a l' usuario y sobre simple presentación del recibo de caja. La garantía

consiste en sustituir a las partes defectuosas. Esta garantía no es aplicable en caso de explotación no conforme a las normas del aparato, ni en caso de daños causados por intervenciones no autorizadas o por negligencia por parte del comprador. La garantía no se aplica sobre los daños causados por un fallo del herramienta.

NL. GARANTIE

Dit gereedschap heeft een garantie tegen constructiefouten en materiaaldefecten, die geldig is vanaf de aankoopdatum door de gebruiker, op vertoning van de kassabon. De garantie betreft de vervanging van de defecte onderdelen. Deze garantie is niet van toepassing indien het apparaat niet volgens de normen gebruikt is, noch in geval van schade veroorzaakt door oneigenlijk gebruik of nalatigheid van de koper. De garantie is niet van toepassing op schade voortvloeiend uit een defect van het gereedschap.

PT. GARANTIA

Esta ferramenta tem uma garantia contratual contra qualquer defeito de construção e de material, a partir da data de venda ao utilizador e sobre simples apresentação do talão da caixa. A garantia consiste em substituir as partes defeituosas. Esta garantia não é aplicável no caso de exploração não conforme às normas do aparelho, nem em caso de danos causados pelas intervenções não autorizadas ou por negligência da parte do comprador. A garantia não se aplica para os danos causados por uma falha da ferramenta.

EL. Εγγύηση

Το εργαλείο αυτ'ο φέρει συμβατικ'η εγγύηση για οποιούδηΠοτε ελ'αττωμα κατασκευής αΠ'ο την ημερομηνία Π'ώλησης, στο χρ'οστη, με αΠλ'η Προσκ'ομιση της αΠ'ο'οεικής αγοράς. Η εγγύηση αΠοτελείται ατ'ο την αντικατ'ασταση των ελαττωματικ'ων τμημ'ατων. Η Παρο'υσα εγγύηση σεν εφαρμ'οζεται σε Περ'ύπτωση χρ'ησης μη σ'υμφωνής, με τα Προ'οτυπα της συσκευής, η σε Περ'ύπτωση ζημι'αζ Που Προκλ'ηθηκε αΠ'ο μη εγκεκριμ'ενη επ'εμβαση 'η αΠ'ο αμ'ελεια του αγοραστ'η. Η εγγύηση 'οεν εφαρμ'οζεται στις ζημι'ες Που Προκαλο'υνται αΠ'ο βλ'αθη του εργαλειου Σταυρο'ι κενο'υ Διαστημιο - Παρ'εμβυσμα

PL. GWARANCJA

Narz'dzie jest obj'ete gwarancją na wszelkie wady konstrukcyjne i materiałowe, licząc od daty sprzedaży u'ytkownikowi i po okazaniu paragonu kasowego. Gwarancja obejmuje wymian' cz'Ac'i wybrakowanych. Gwarancja nie, znajduję zastosowania w przypadku u'ytkowania niezgodnego z normami urz'adzenia, ani w przypadku szkód spowodowanych działaniami

niedozwolonymi lub zaniedbaniami ze strony nabywcy. Gwarancją nie obejmuj' szkód powstał'ych z powodu upadku urz'adzenia.

SV. GARANTI

Detta verktyg har en avtalsenlig garanti mot konstruktions och materiafel, från och med tidpunkten för användarens inköp och genom uppvisning av kassavittot. Garantin består i att ersätta de bristfälliga delarna. Denna garanti gäller inte om användningen inte motsvarar apparatens standarder, inte heller vid skador som orsakas av ej tillåtna ingrepp eller på grund av köparens vårdslöshet. Garantin gäller inte förskador som orsakats av att verktyget fungerat bristfälligt.

FI. TAKUU

Tämän laitteen takuu on voimassa sopimuskennukaisesti kattaa kaikki rakenne- ja materiaaliiviat lukien ostopäivästä kassakuitista vastaan. Takuu sisältää viallisten osien korvaamisen. Takuu ei korvaa ohjeidenvastaista käyttöä eikä valtuuttamattomien henkilöiden käsitteilyä tai ostajan huoltamattomuudesta aiheutuneita vahinkoja. Takuu ei vastaa myöskään toimintahäiriöistä aiheutuneita vahinkoja.

BU. Гаранция

Този инструмент е под договорна гаранция срещу всякакъв дефект в изработката и използваните материали, считано от датата на продажба на потребителя и само срещу представяне на касовата бележка. Гаранционното обслужване се състои в замяна на дефектните части. Настоящата гаранция не е валидна когато апаратът се използва по начин, несъответстващ на стандарта за работа с него, както и в случай на щети, нанесени от неоторизирани лица, или вследствие на проявена небрежност от страна потребителя. Гаранцията не покрива щети, произтекли вследствие на техническа неизправност на апарата.

DA. GARANTI

Dele værktøj er dækket af en garanti-kontrakt for konstruktions- og materialefjøl, som gælder fra købsdatoen ved visning af kassebonen. Garantien består i at udskifte de defekte dele. Garantien dækker ikke fejl opstået som følge af anvendelse, som ikke overholder standarderne for apparatet, eller skader opstået ved ikke autoriserede indgreb eller sløshed fra brugerens side. Garantien dækker ikke skader opstået, fordi værktøjet har svigtet.

SERVICE APRÈS VENTE - AFTER SALE SERVICE

FARGROUP EUROPE - 192, Avenue Yves Farge - 37700 St. Pierre-des-Corps - FRANCE

fargroup@fargroup.net

**RO. GARANTIE**

Acest aparat este garantat din punct de vedere contractual împotriva tuturor viciorilor de construcție și de material, începând de la data vânzării lui către utilizator și la simpla prezentare a bonului de casă. Garanția constă în înlocuirea componentelor defecte. Această garanție nu se aplică în cazul exploatarii în alt mod decât cel recomandat de normele aparatului și nici în caz de stricăciuni provocate de intervenții neautorizate sau prin neglijența cumpărătorului. Garanția nu se aplică asupra pagbelor cauzate de o defectare a aparatului.

RU. ГАРАНТИЯ

Данное изделие обладает имеющей, силу контракта гарантией, покрывающей все возможные дефекты изготовления и материала. Гарантия вступает в силу с даты продажи изделия пользователю, для этого достаточно сохранить и предъявить полученный в кассе чек. Гарантия обязывает изготовителя заменить дефектные части изделия. В случае не соответствующего нормам использования изделия, не санкционированного демонтажа или ремонта или небрежного обращения действие гарантии прекращается. Гарантия не покрывает ущерба, возникшего в результате соев в работе изделия.

TU. GARANTI

Bu araç, satış tarihinden itibaren, kullanıcıların sadece vezne alıncısını sunmasıyla tüm üretim ve malzeme hatasına karşı garantilidir. Garanti eksik olan kısımları değiştirme içindir. Bu garanti aracin şartlarına uygun olmayan işleme durumunda, izin verilmeyen kullanımlardan kaynaklanan hasarlarda veya alıcının işteği durumunda uygulanmaz. Garanti malzemenin bir eksikliğinden meydana gelen bir zararda uygulanmaz.

CS. ZÁRUKA

Pro tento nástroj platí smluvní záruka na všechny výrobní a materiálové vady od data prodeje uživateli a na základě předložení pokladního bloku. Záruka spočívá ve výměně vadných částí. Iato záruka neplatí v případě použití přístroje, které neodpovídá normám, ani v případě škod způsobených nepovolenými zásahy nebo nedbalostí ze strany kupujícího. Záruka se nevztahuje na škody způsobené závadou nástroje.

SK. ZÁRUKA

Pre tento nástroj platí zmluvná záruka na všetky výrobné a materiálové chyby od dátumu predaja užívateľovi a na základe predloženia pokladničného

bloku. Záruka spočívá vo výmene chybných častí. Táto záruka neplatí v prípade použitia prístroja, ktoré nezodpovedá normám, ani v prípade škôd spôsobených nepovolenými zásahmi alebo nedbalosťou zo strany kupujúceho. Záruka sa nevztahuje na škody spôsobené poruchou nástroja

HE. GARANTIA

חשבונית קופה. האחריות-משמעה מיום המכירה למשתמש עם הצגת מפני כל ליקוי בייצור או בחומר, החל הי עככלי זה חלה האחריות לפי חוזה זה שנגרם על ידי התערבותי תלמך שאינו מתאים לתקנים ובמקרה של אינה חלה במקרה של שימוש במכשיר החלפה תחלקם הלקויים אחריות זו חלה על נזק שנגרם על ידי תקלה בכלי רשלנות מאת הקונה. האחריות בינה נמוכות או על ידי

AR. الضمان

على مجرد تقديم بطاقة الشراء يتغل في تاريخ البيع الذي المستعمل وبناءا في التصدي عوفي المواد. اعجابا من الخ ده مصنفة تذاذي من أي عيب في حالة تعرضه لتلفات إن فده غير المطابق لمعايير الجودة. ولا تأيلا للتطبيق في حالة الاستخدام المتكرر أو الغلظة لا يكون هذا الضمان الناتج عن خلل الضمان فباي استدال المشتري لا ينطبق الضمان على الضرر غير مبررة أو في حالة الأعمال من قبل تأتية عن عمليات تدخل

HU. GARANCIA

Erre a szerszámra szerződéses garanciát vállalunk bármilyen gyártási és anyaghiba felmerülése esetére, a fogyasztó részére történt eladás napjától számítva, a pénztári blokk egyszerű felmutatása ellenében. A garancia a hibás alkatrészek cseréjére terjed ki. Ez a garancia nem érvényes, ha a készüléket nem rendeltetésszerűen használták, sem illetéktelen beavatkozások, vagy a vásárló hanyagsága okozta károk esetén. A garancia nem fedezi azokat a károkat, melyeket a szerszám hibás működése okozott.

SL. GARANCIJA

To orodje je z garancijsko pogodbo zaščiteno proti vsem napakam v izdelavi in v sestavnem materialu od datuma prodaje naprej in ta velja ob predložitvi blagajniškega računa. Garancija velja za zamenjavno delov z napako. Ta garancija ne velja za uporabo orodja, ki ni v skladu z normami, predpisanimi za omenjeno orodje in za primere okvar, ki nastanejo zaradi nedovoljenih posegov na orodju ali zaradi malomarnega rokovanja kupca. Garancija ne velja za škodo, ki jo lahko povzroči okvara orodja.

ET. GARANTII

See tööriist kuulub lepingu järgi garantiiremonti arvestades alates müümise päevast ja kasutajale alusel kasutatavale kõigi konstruktsiooni- ja materjalivigade puhul. Garantii seisneb defektsete osade väljavahetamises. See garantii ei kehti aparadi normide ebatavalise eiramise puhul ega ostja poolt keelatud viisil kasutamisest või hooletusjätmisest

tulenevate kahjude korral. Garantii ei kehti seadme defektidest põhjustatud kahjude puhul

IV. GARANTIJA

Sis prietaisas yra užtikrinamas kaip itin geros kokybės, nuo jo pardavimo datos iki jo panaudojimo, ir jam yra suteikiama garantinis talonas. Garantijos metu galima pakeisti atsiradusius trumplaikius gedimus. Si garantija netaikoma esant netaikamam naudojimui ar nesilaikant reikiam šio aparato vartojimo instrukcijų, tai pat pačiam pirkejuji jį sugadinus. Garantija taip pat netaikoma, prietaisą naudojant ne pagal paskirtį ir jį apgadinus

IT. GARANTIA

Sim darbarikam ir ligumā noteikta garantija visiem defektīmi, kas saistās ar konstrukciju un materiālu, sākot ar pārdošanas datumu, kad mašīnu pārdod lietotājam un vienkāši uzrādāt kases čeku. Garantija iekļauj bojāto daļu nomainu. Šī garantija nav derīga, ja aparātš nav lietots saskaņā ar drošības noteikumiem, ne gadījumos, ja bojājumi radušies nesankcionētas iekaujšanas gadījumā vai arī pircēja nolaidības dēļ. Garantija nav derīga, ja bojājumi radušies darbarika defekta dēļ

HR. JAMSTVO

Ovaj alat ima ugovorno jamstvo u slučaju bilo kakvih nedostataka u konstrukciji i materijalu, od datuma prodaje korisniku uz jednostavno predocenje računa. Jamstvo se sastoji u zamjeni neispravnih dijelova. Ovo se jamstvo ne primjenjuje u slučaju uporabe i eksploatacije koja nije sukladna standardima uređaja, niti u slučaju štete uzrokovane neovlaštenim intervencijama ili nemanom kupca. Jamstvo se ne primjenjuje na štetu uzrokovanu nekim nedostatkom alata.



ei
id



in
os
a-
tu
a-
ja
i-
o
j
a.
ir



ta
as
ar
od
es
lu
ja
as
u-
as
as
ni



a-
ji
i-
a.
ih
je
ja
iti
m

tu





FAR GROUP EUROPE

Une société du groupe **SIGMA**

192, Avenue Yves Farge
37700 St. Pierre-des-Corps
FRANCE

fartools.com

