

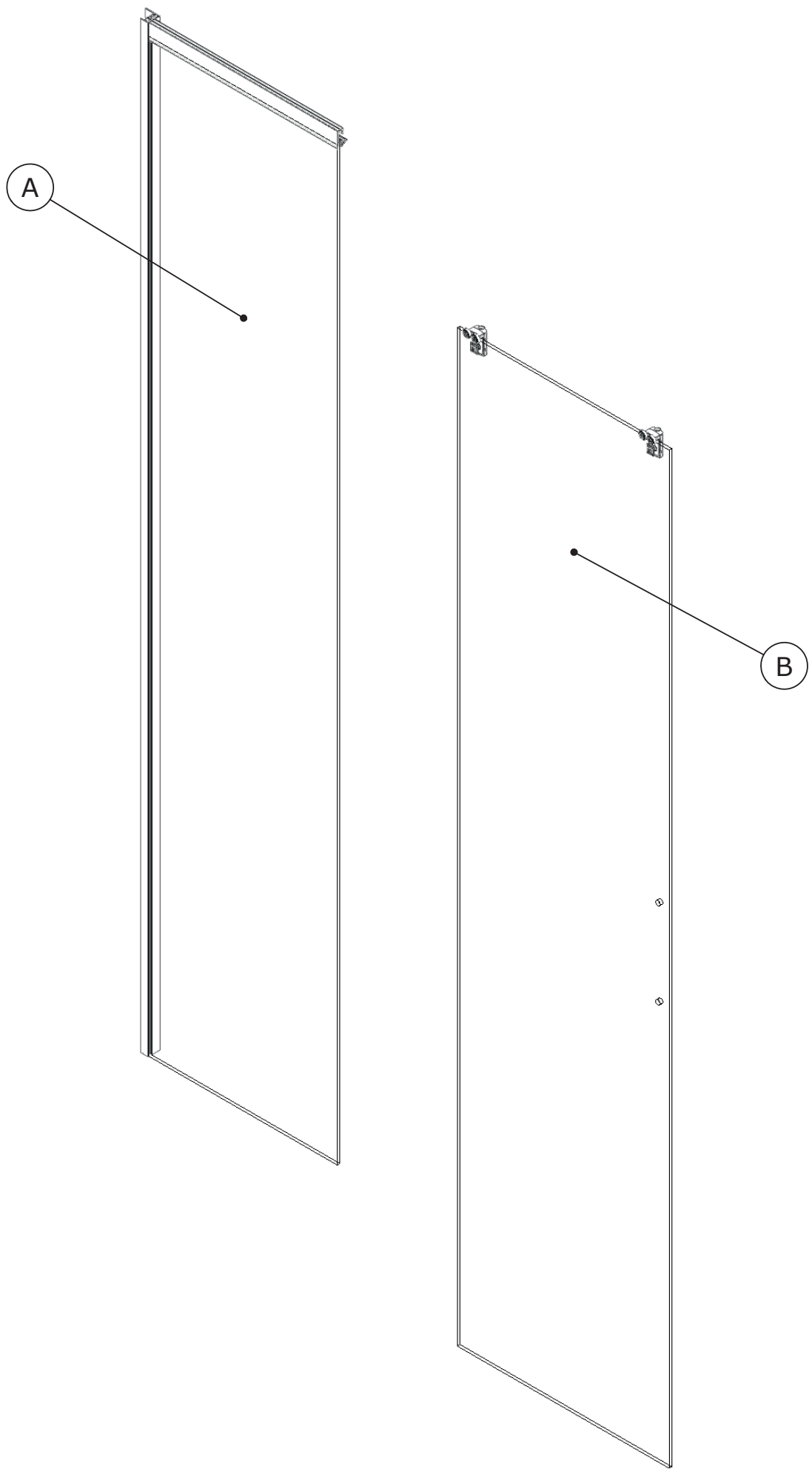

NOTICE DE MONTAGE
INSTALLATION INSTRUCTIONS
MANUAL DE INSTALACI3N
MANUAL DE INSTALAC3O
ISTRUZIONI DI MONTAGGIO
INSTALLATIE VOORSCHRIFTEN
INSTALLATIONSANLEITUNG

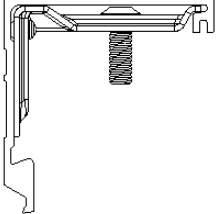

Attention aux étapes :
Check installation steps :
Atención a los pasos :
Atenção aos passos: **P. 8 - 14 - 32**
Attenzione ai passi :
Aandacht voor de stappen :
Achtung vor den Schritten :

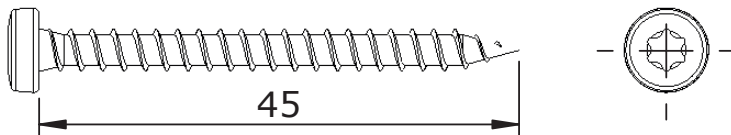
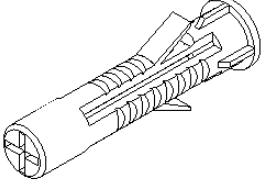
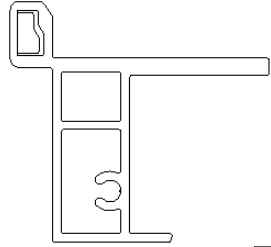
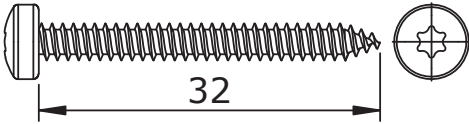
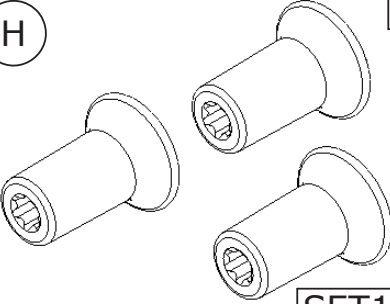
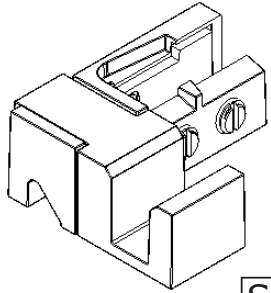
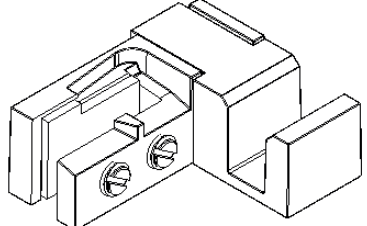
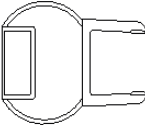

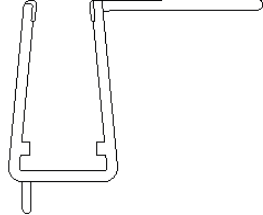
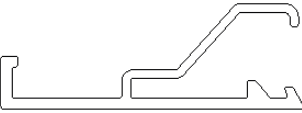
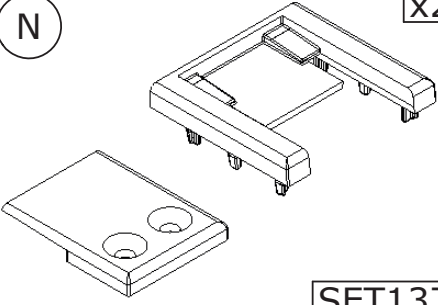
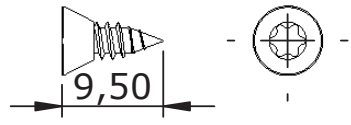
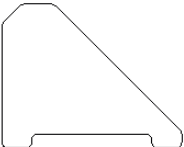
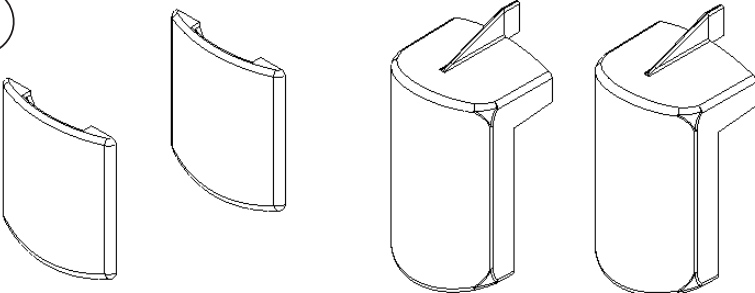
<p>C x2</p>  <p style="text-align: right;">6268</p>	<p>D Ø4 x6</p>  <p style="text-align: center;">45</p> <p style="text-align: right;">VIS231</p>	
<p>E x6</p>  <p style="text-align: right;">CHE02</p>	<p>F x1</p>  <p style="text-align: right;">6279</p>	<p>G Ø3.5 x2</p>  <p style="text-align: center;">32</p> <p style="text-align: right;">VIS214</p>
<p>H x2</p>  <p style="text-align: right;">SET134</p>	<p>I x1</p>  <p style="text-align: right;">SET130</p>  <p style="text-align: right;">SET131</p>	
<p>J x1</p>  <p>Lg=1949mm AI171</p>	<p>K x1</p>  <p>Lg=1969mm J782</p>	<p>L x1</p>  <p>Lg=950mm J780</p>
<p>M x2</p>  <p style="text-align: right;">6270</p>	<p>N x2</p>  <p style="text-align: right;">SET137</p>	<p>O Ø3.5 x2</p>  <p style="text-align: center;">9,50</p> <p style="text-align: right;">VIS261</p>
<p>P x1</p>  <p style="text-align: right;">6285</p>	<p>Q x1</p>  <p style="text-align: right;">SET135</p>	

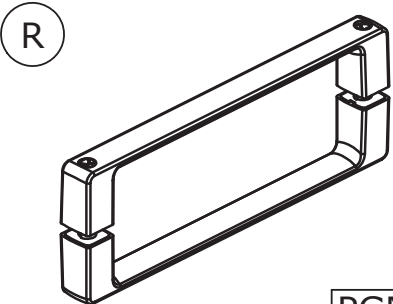
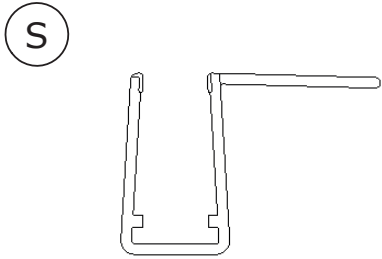
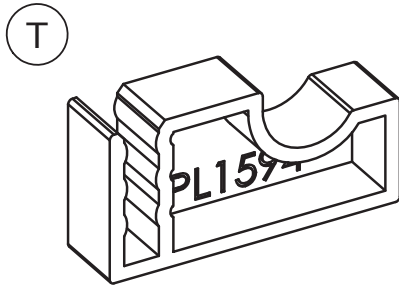
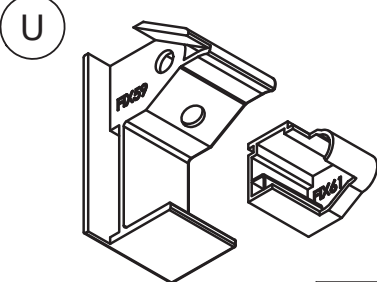
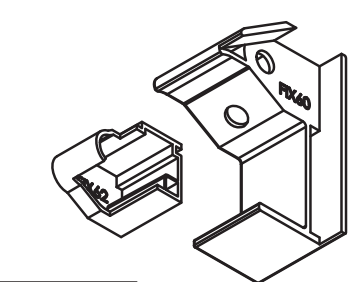
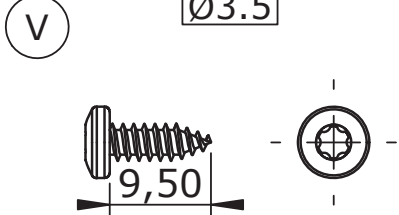
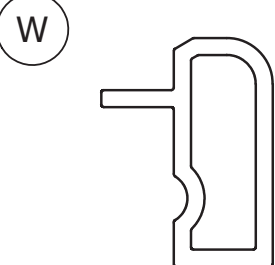
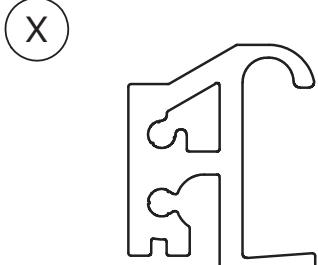
 <p>(R) x1</p> <p>PGN49</p>	 <p>(S) x1</p> <p>Lg=1946mm</p> <p>J946</p>	 <p>(T) x2</p> <p>PPL1594</p>
 <p>(U) x1</p> <p>SET231</p>	 <p>(V) x1</p> <p>SET232</p>	 <p>(V) x3</p> <p>Ø3.5</p> <p>9,50</p> <p>VIS237</p>
 <p>(W) x1</p> <p>Lg=250mm</p> <p>6465</p>	 <p>(X) x1</p> <p>6464</p>	

Les quantités données sont les quantités utiles au montage. les sachets fournis contiennent des pièces supplémentaires.
 The quantities given are what are required for the installation. There may be some surplus in the package provide.
 Las cantidades indicadas son las cantidades necesarias para el montaje. Las bolsitas incluidas contienen piezas suplementarias.
 As quantidades indicadas são as quantidades necessárias para a montagem. Os sacos fechados contém peças adicionais.
 Le quantità fornite sono le quantità necessarie al montaggio. I sacchetti forniti contengono pezzi supplementari.
 De aangegeven aantallen zijn vereist voor de montage. De verpakking bevat extra onderdelen.
 Die Mengenangaben beziehen sich auf die für die Montage nötigen Teile. Eventuell weitere beige packte Teile ignorieren.

● Outillage nécessaire ● Tools required ● Equipamiento necesario
 ● Attrezzatura necessaria ● Benodigde gereedschap ● Werkzeuge erforderlich

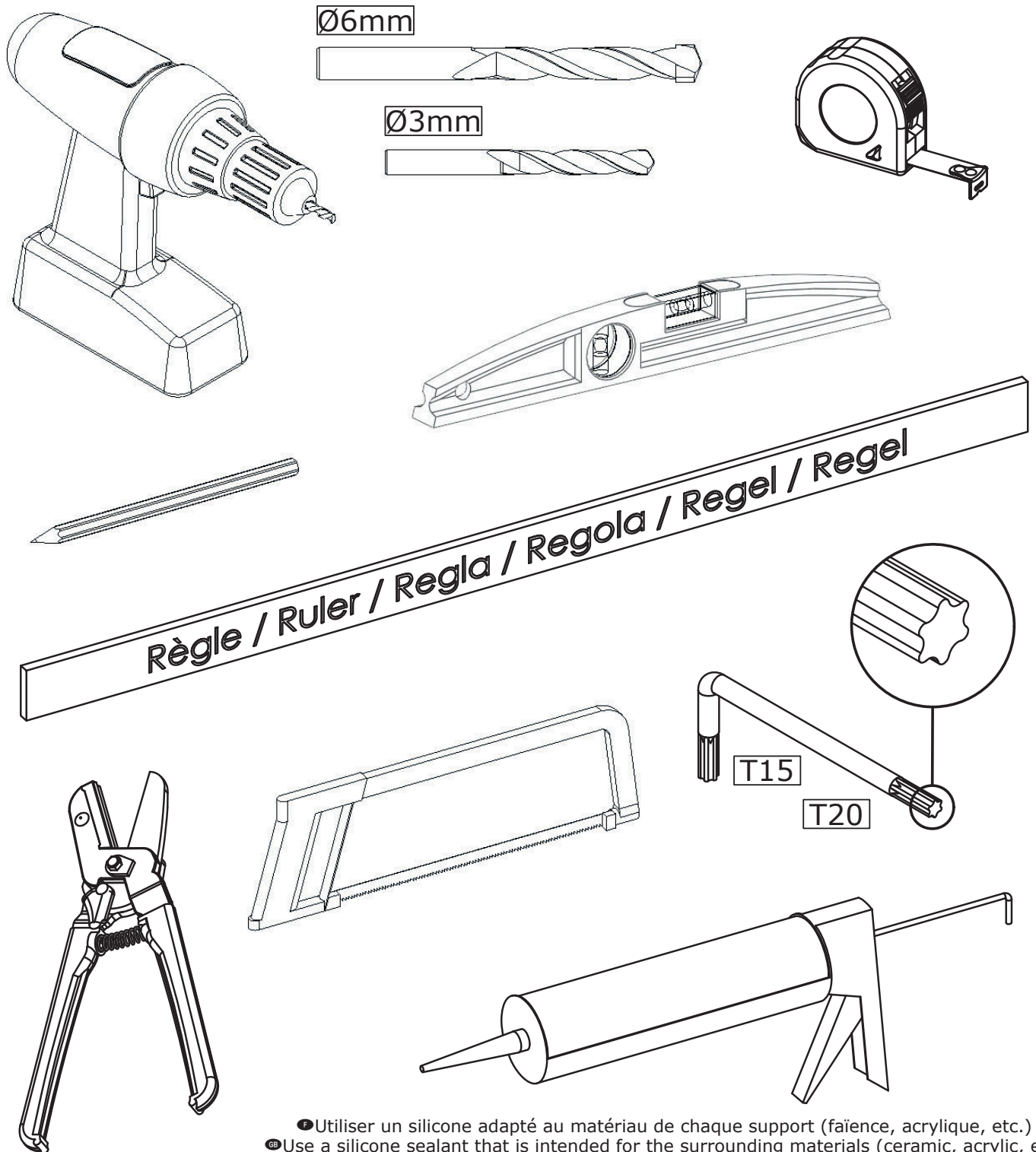

- Utiliser un silicone adapté au matériau de chaque support (faïence, acrylique, etc.)
- Use a silicone sealant that is intended for the surrounding materials (ceramic, acrylic, etc.)
- Usar una silicona adecuada para cada tipo de material (loza, acrílico, etc.)
- Utilizzare un silicone adatto a qualsiasi materiale (ceramica, acrilico, ecc.)
- Gebruik siliconenkit die geschikt is voor iedere ondergrond (tegelwerk, acryl, etc.)
- Für das jeweilige Trägermaterial (Stein, Acryl usw.) geeignetes Silikon verwenden.



Réversibilité - Reversibility - Reversibilidad - Reversibilidade
Reversibilida - Omkeerbaarheid - Wahlweise Montage

Montage à gauche
Left hand
Montaje a la izquierda
Montagem à esquerda
Montaggio a sinistra
Montage links
Montage links

Montage à droite
Right hand
Montaje a la derecha
Montagem à direita
Montaggio a destra
Montage rechts
Montage rechts



- Vous avez la possibilité de réaliser un montage à droite ou un montage à gauche. Notre notice d'installation décrit un montage à gauche. Si vous voulez réaliser un montage à droite, il vous suffit d'inverser le montage.

- This cubicle can be installed either left or right hand. These installation instructions show a left hand installation.

- Puede realizar un montaje a la derecha o un montaje a la izquierda. Nuestro folleto de instalación describe un montaje a la izquierda. Si desea montar su cabina a la derecha sólo tendrá que realizar el montaje al contrario.

- Pode realizar uma instalação à direita ou uma instalação à esquerda. O nosso manual de instalação descreve uma instalação à esquerda. Se pretende realizar uma instalação à direita, basta inverter a instalação.

- Avete la possibilità di effettuare il montaggio a destra o a sinistra. Il nostro manuale descrive il montaggio a sinistra. Se volete realizzare il montaggio a destra è sufficiente invertire varie fasi di montaggio.

- U kunt de douchecabine rechts of links monteren. Onze handleiding beschrijft de links montage van de cabine. Keer de montage om als u de cabine rechts wilt monteren.

- Sie haben die Möglichkeit, eine Montage auf der linken Seite oder eine Montage auf der rechten Seite durchzuführen. Unsere Montageanleitung beschreibt eine Montage auf der linken Seite. Wenn Sie die Montage lieber auf der rechten Seite durchführen wollen, müssen Sie nur den Montageprozess umkehren.

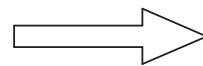
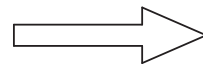
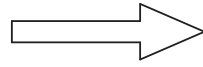

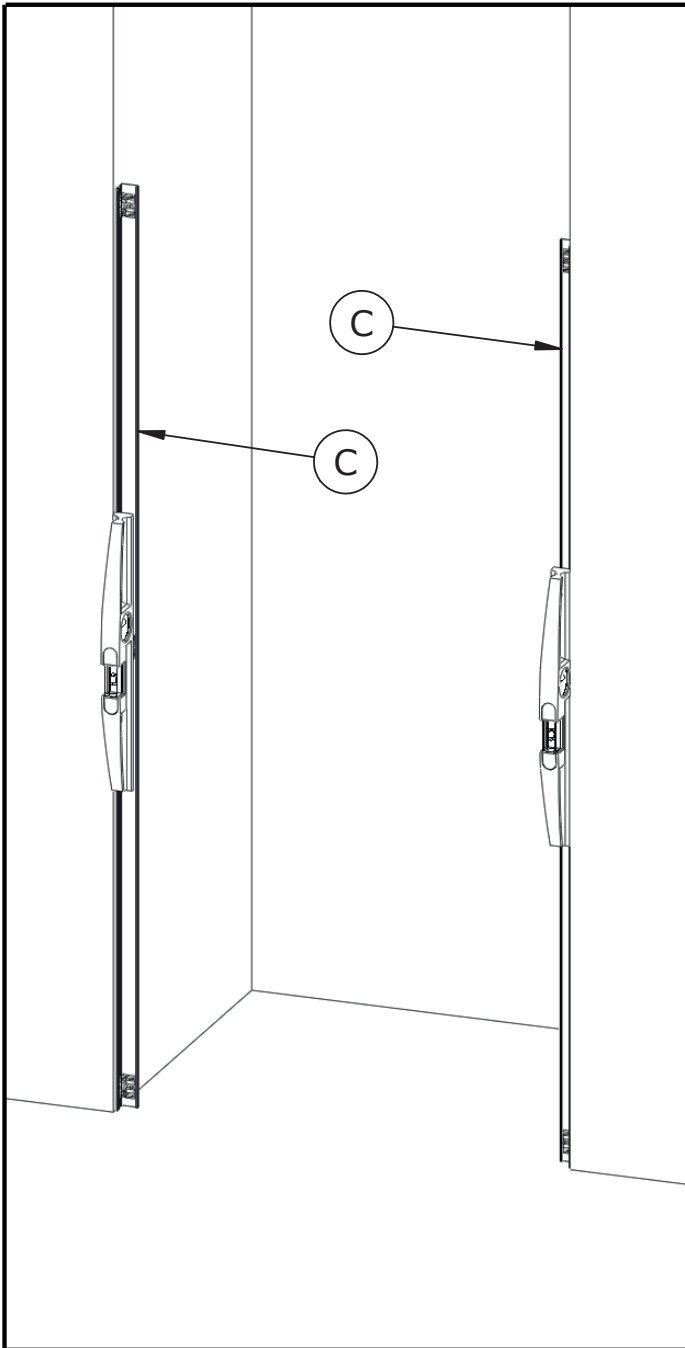

Si receveur - If shower tray
Si plato - Se a base de duche - Se piatto
Als douchebak - Wenn Duschwanne

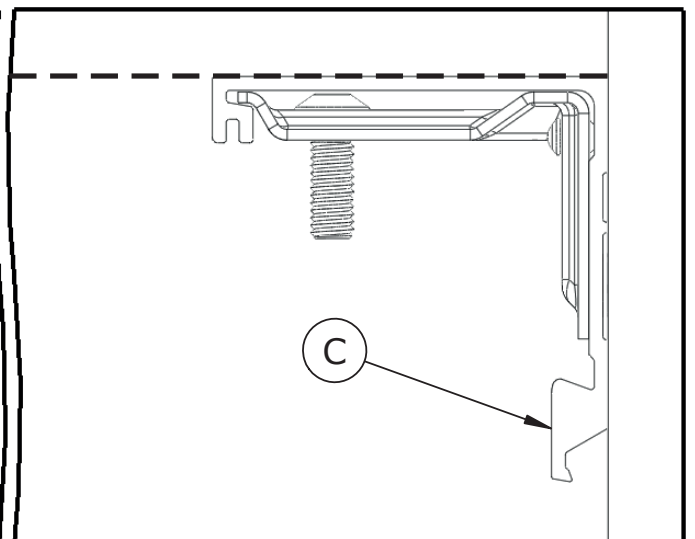
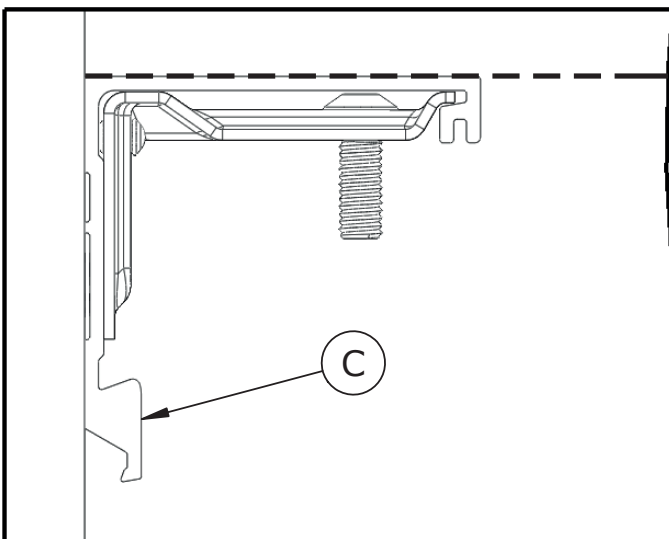
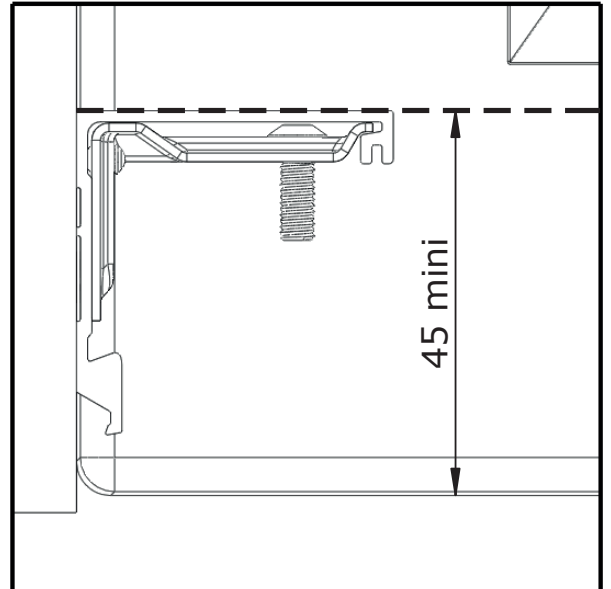

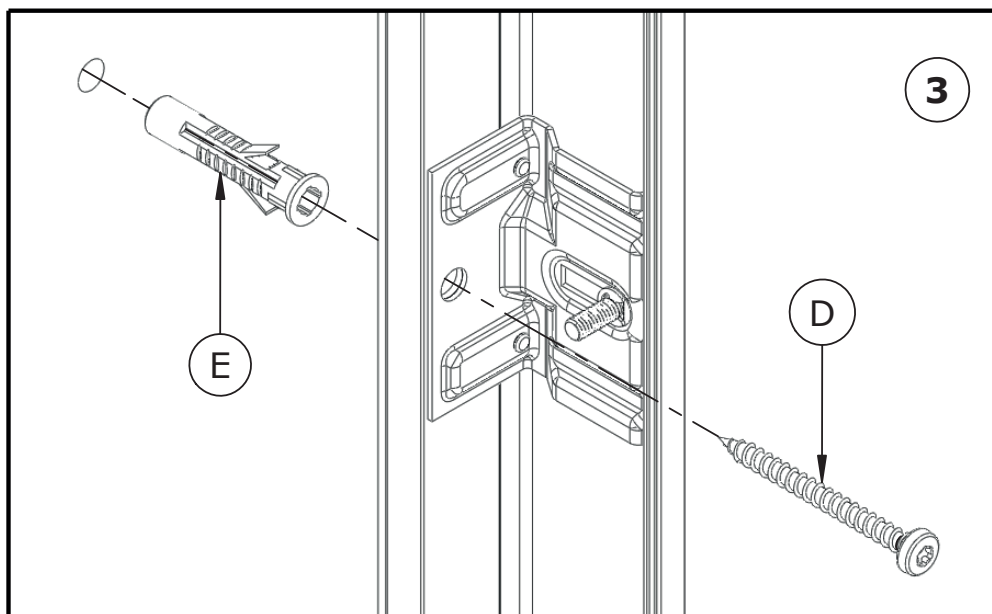
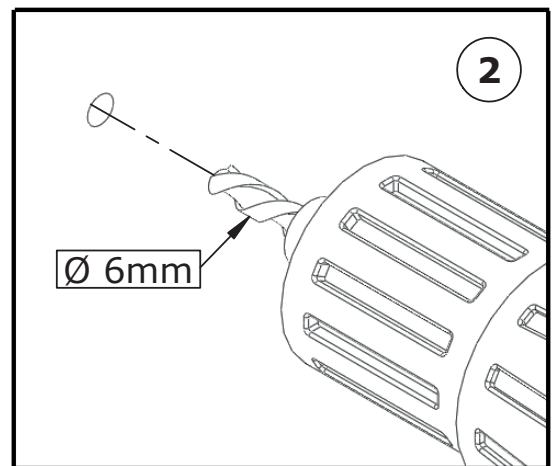
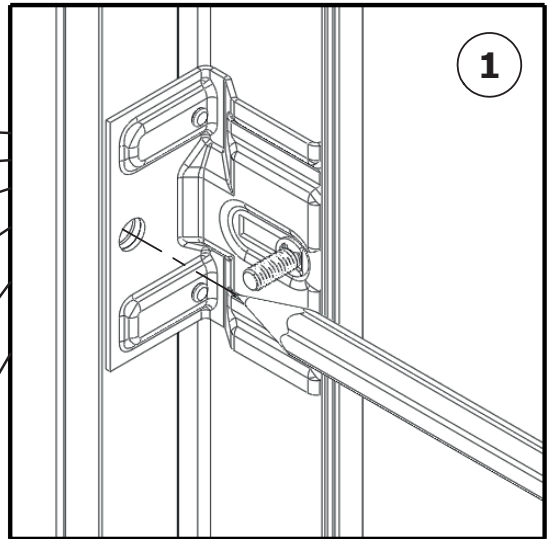
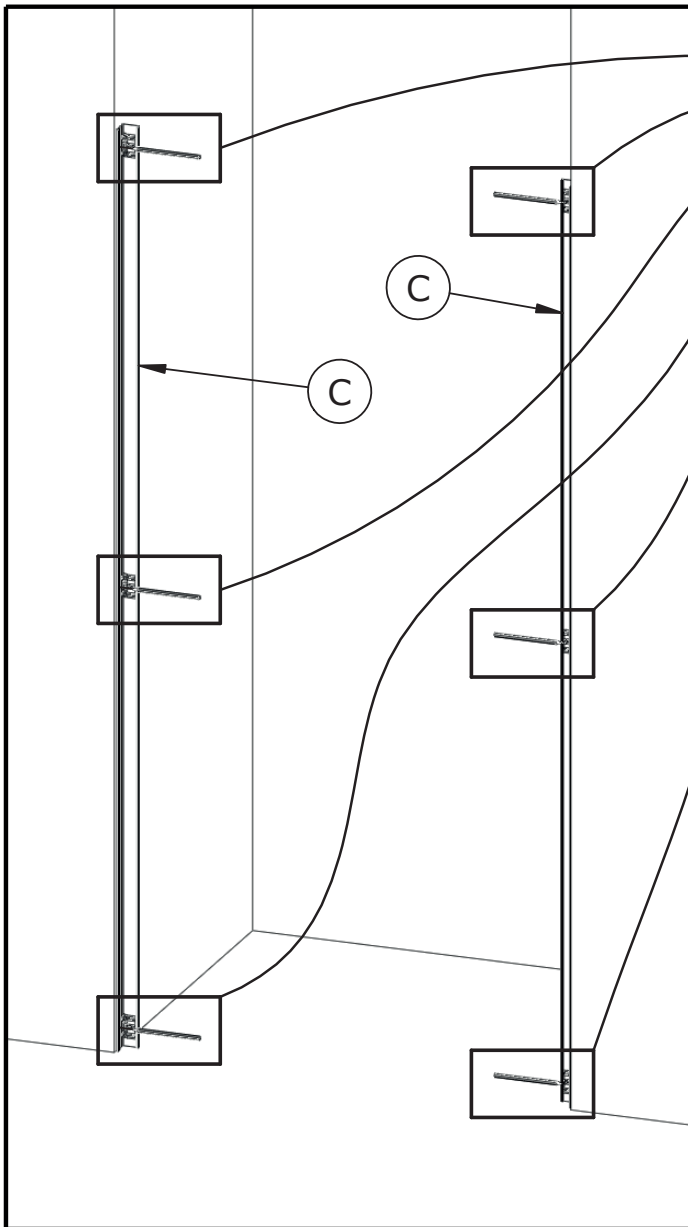

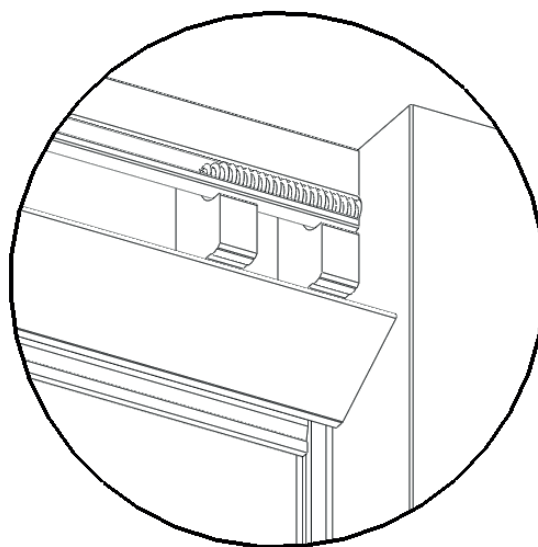
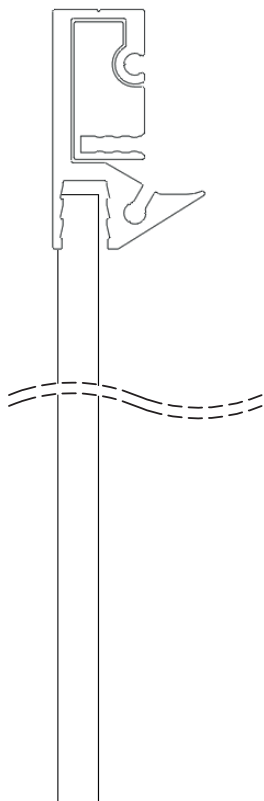
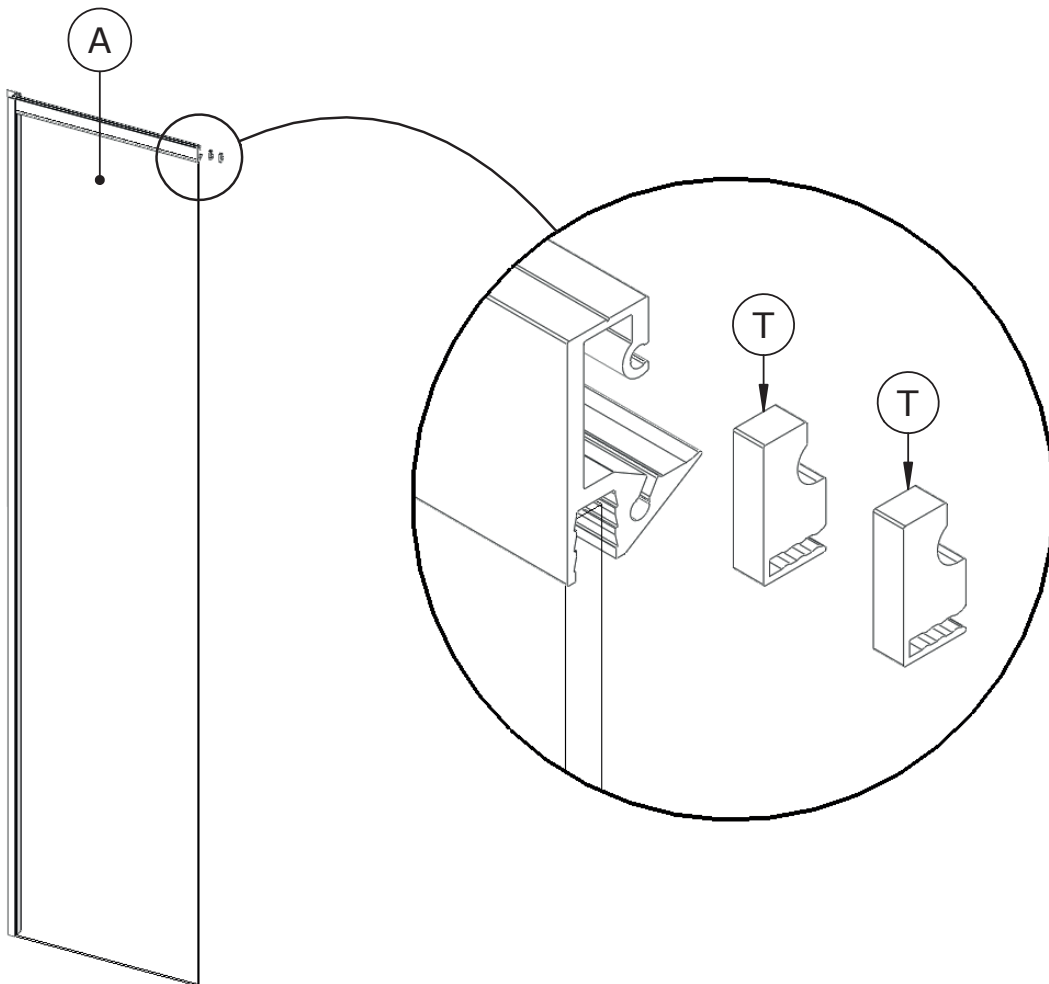

● F Intérieur ● GB Inside
● E Interior ● I Interno
● NL Binnenkant ● D Innen

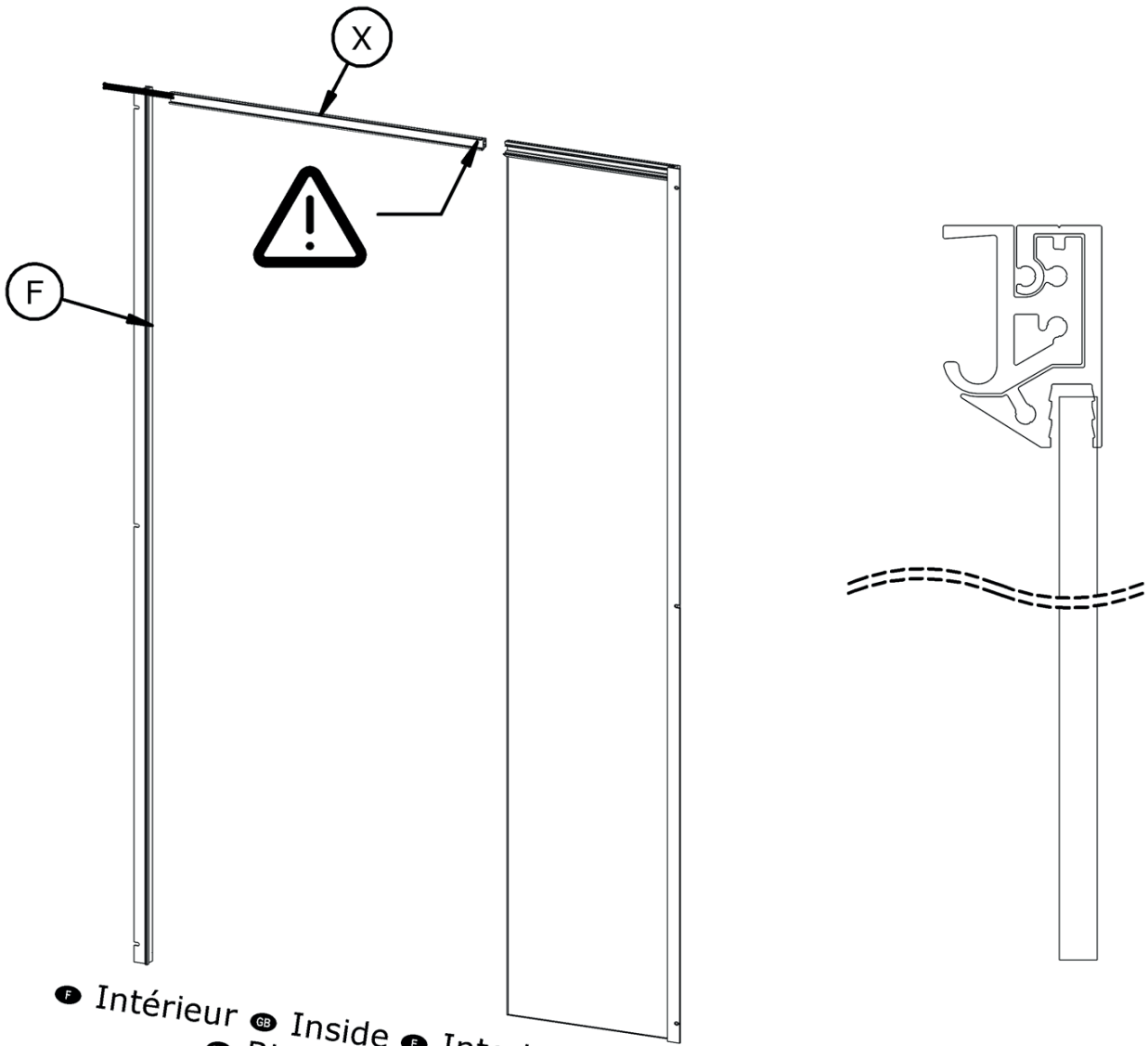

● Intérieur ● Inside ● Interior ● Interno
 ● Binnenkant ● Innen

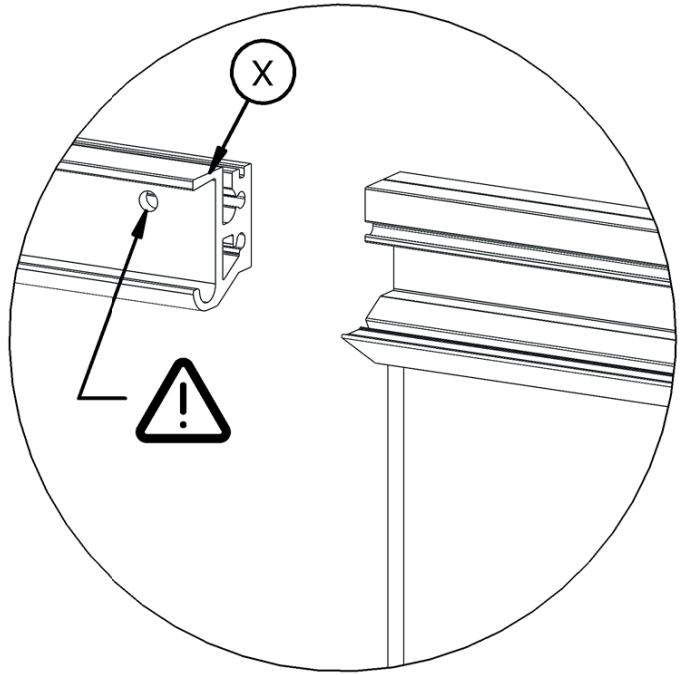
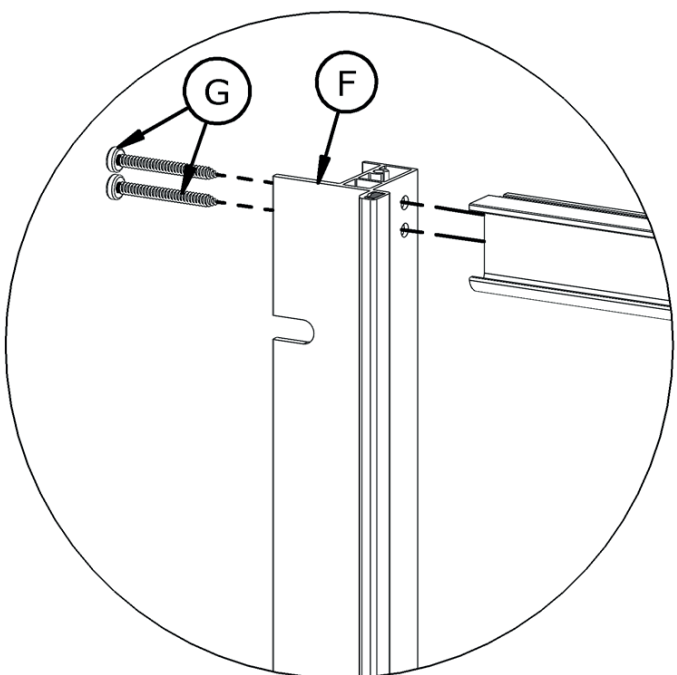

● Intérieur ● Inside ● Interior ● Interno ● Binnenkant ● Innen

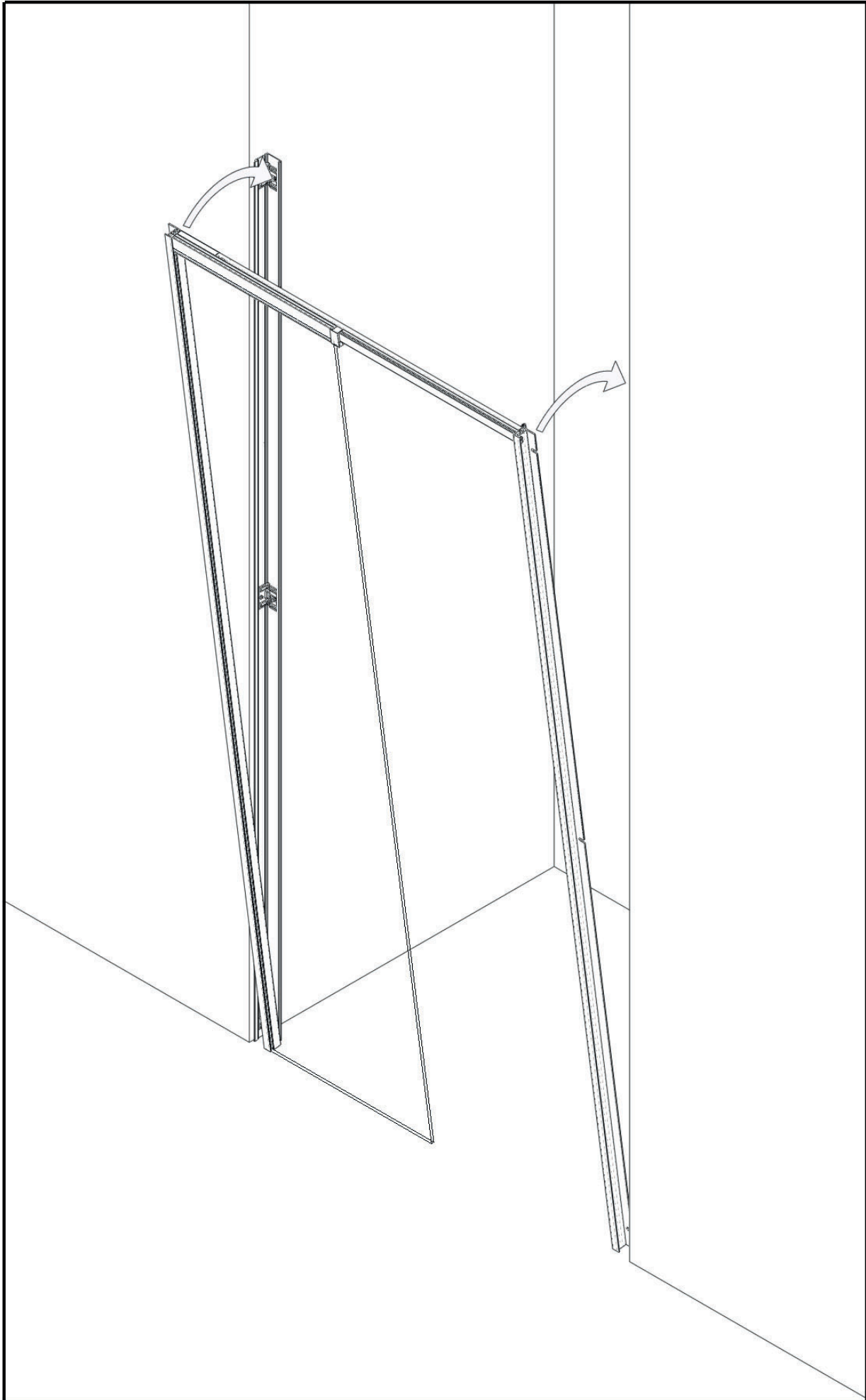

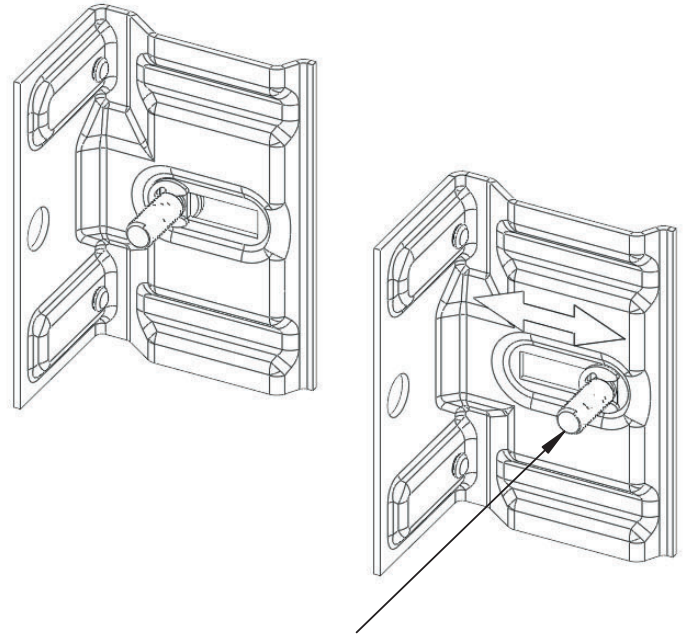

Si nécessaire, desserrer, régler puis resserrer
 If necessary, loosen, adjust and retighten
 Si es necesario, afloje, ajuste y apriete
 Se necessário, desaperte, ajuste e aperte
 Se necesario, allentare, regolare e stringere
 Draai los, indien nodig, stel af en draai vervolgens
 weer vast
 Falls erforderlich, lösen, einstellen und wieder
 festziehen

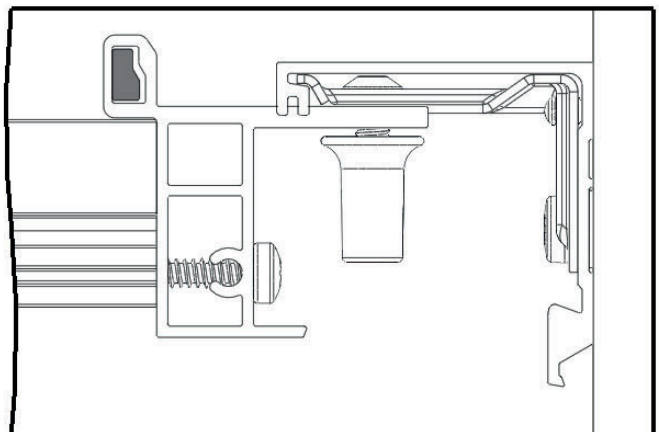
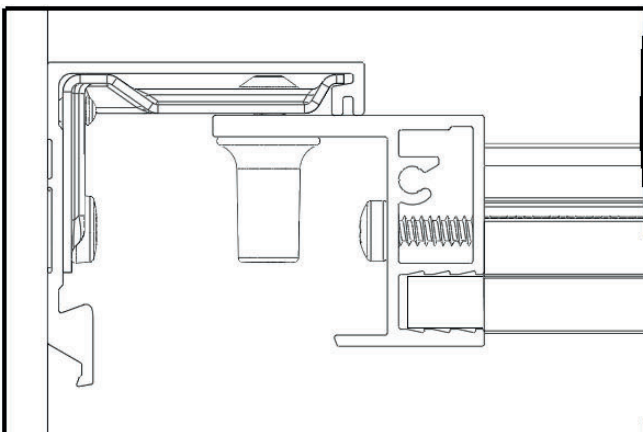
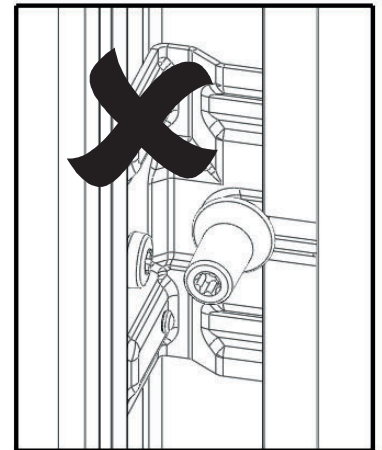
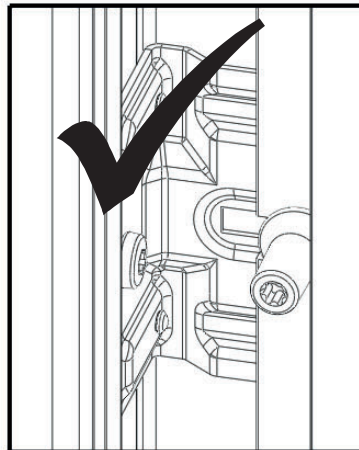
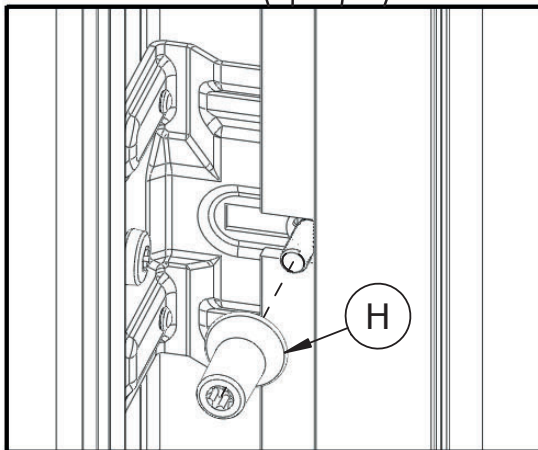

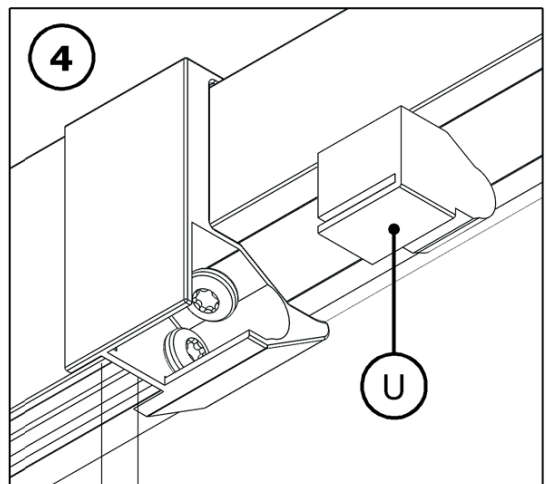
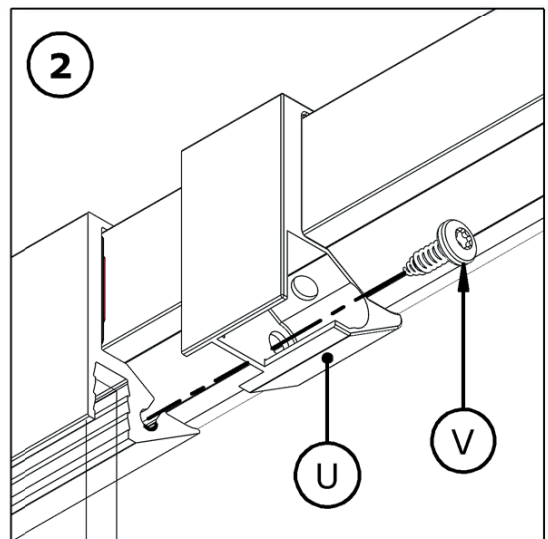
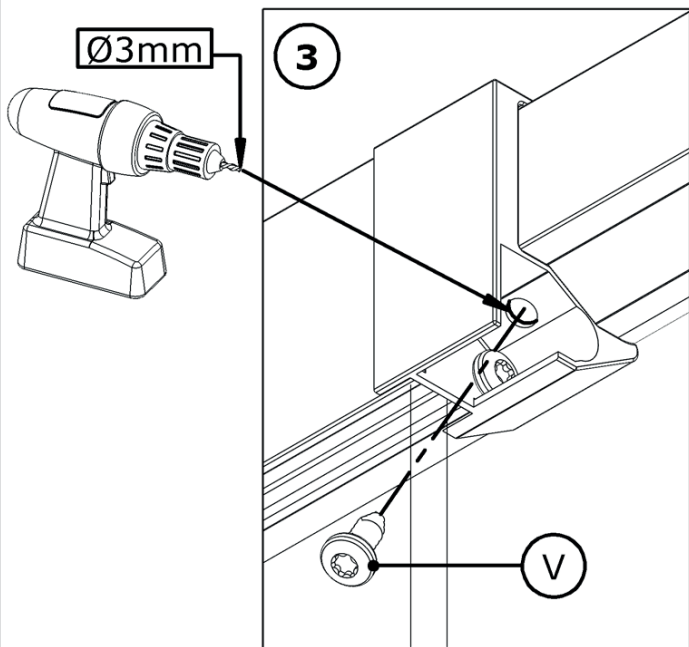
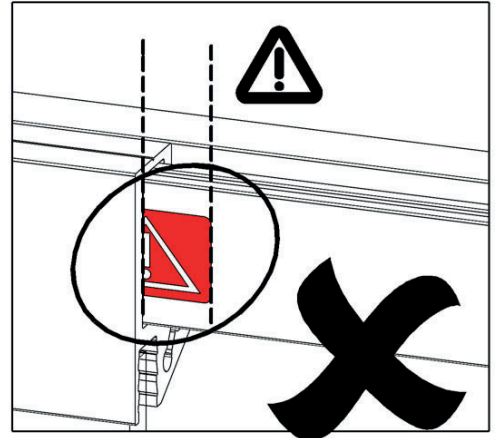
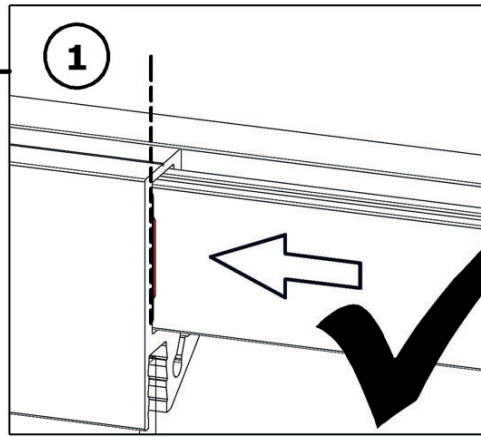
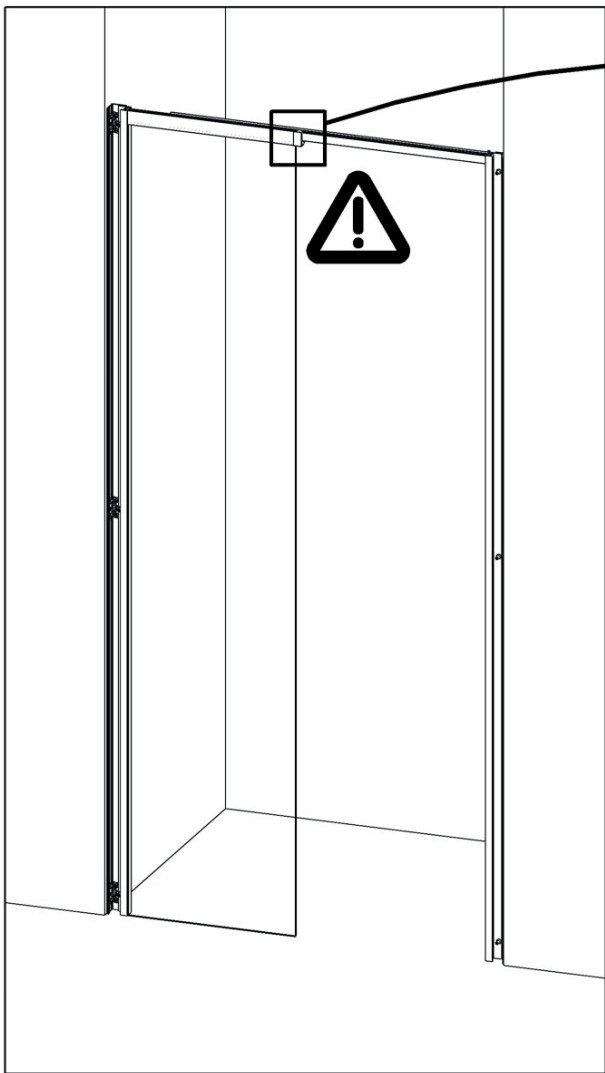

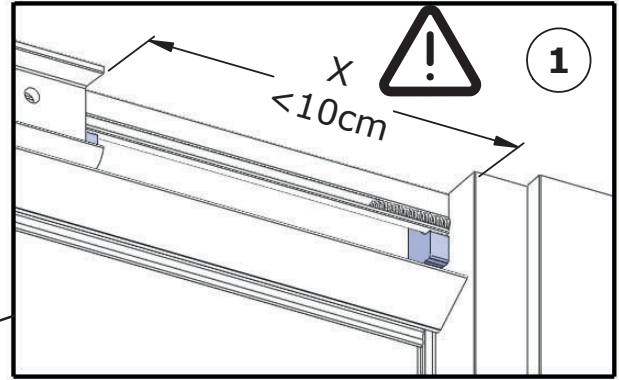
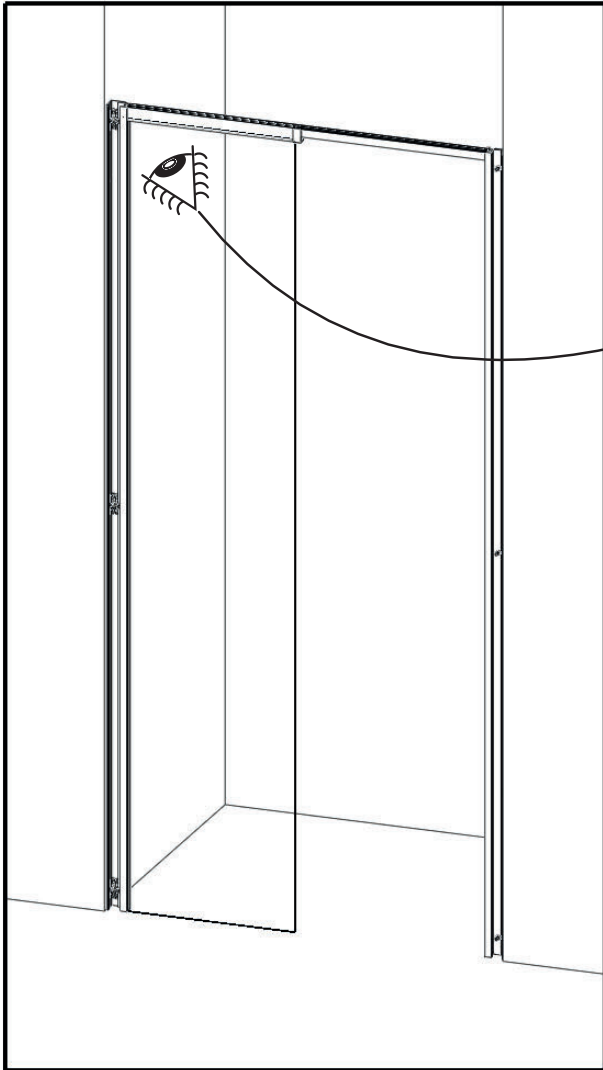

(F) Intérieur (GB) Inside
 (E) Interior (I) Interno
 (NL) Binnenkant (D) Innen

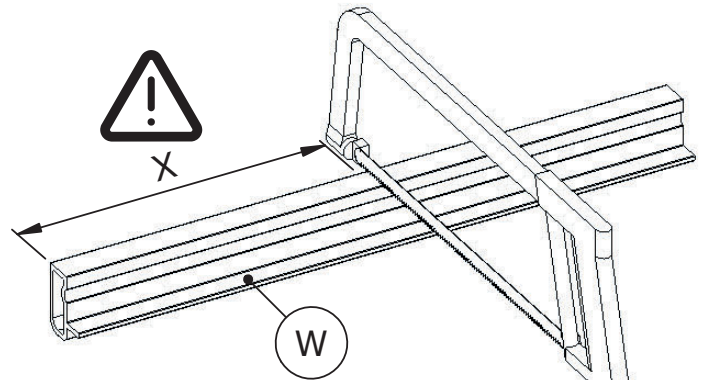

Marquage extension MAXI
 Attente DRT/JFR

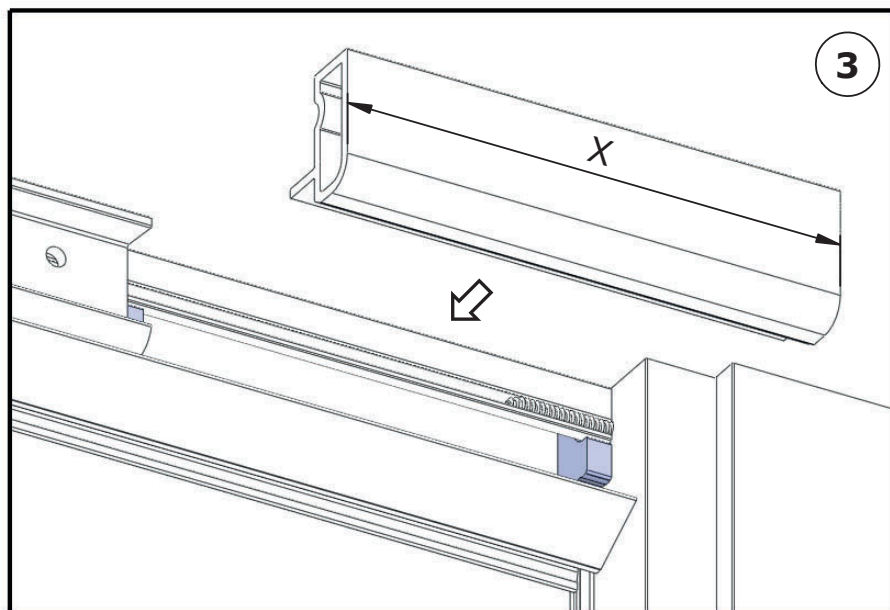

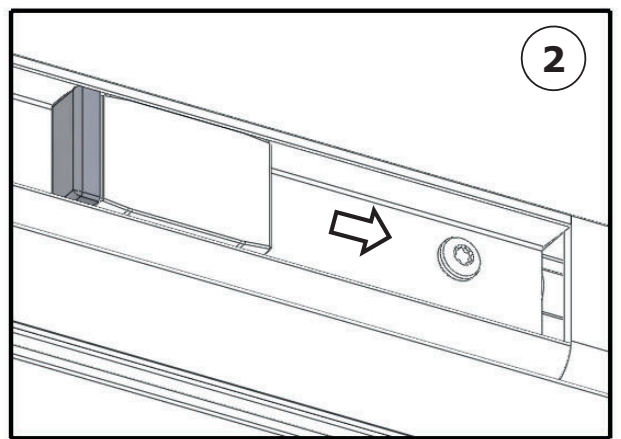
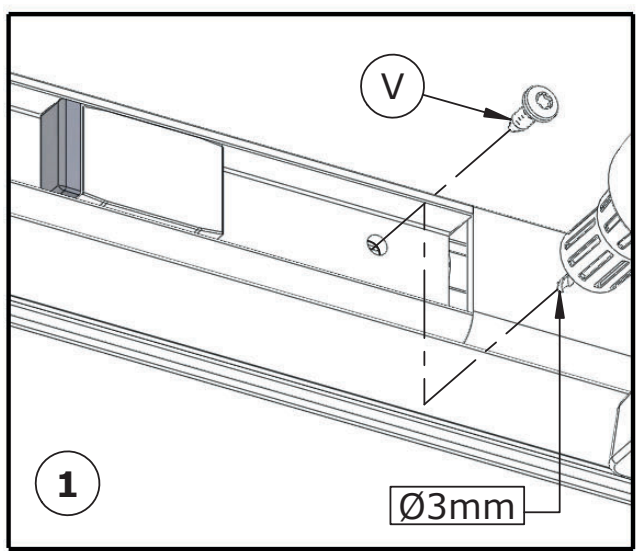

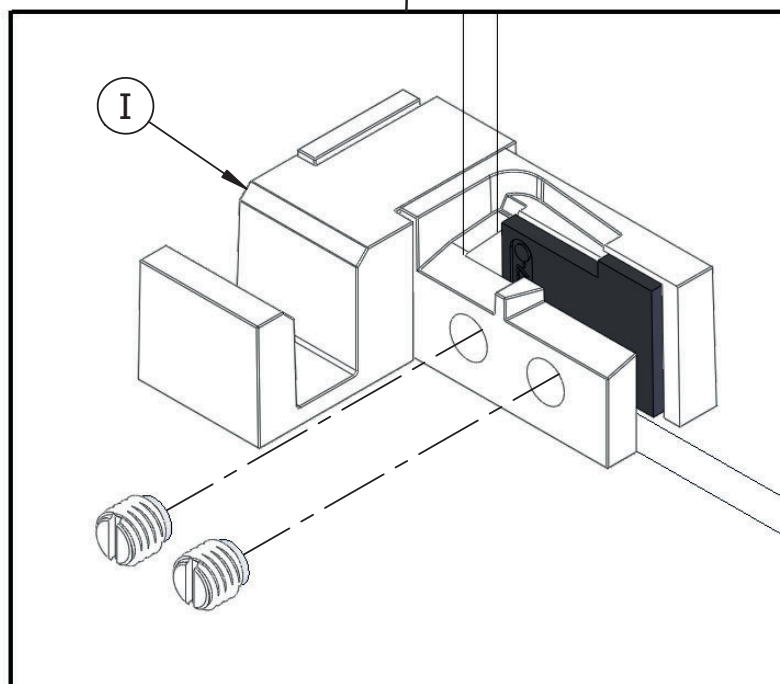

Vue intérieur - Interior view - Vista interior - Vista interior
Vista interna - Binnen aanzicht - Innenansicht

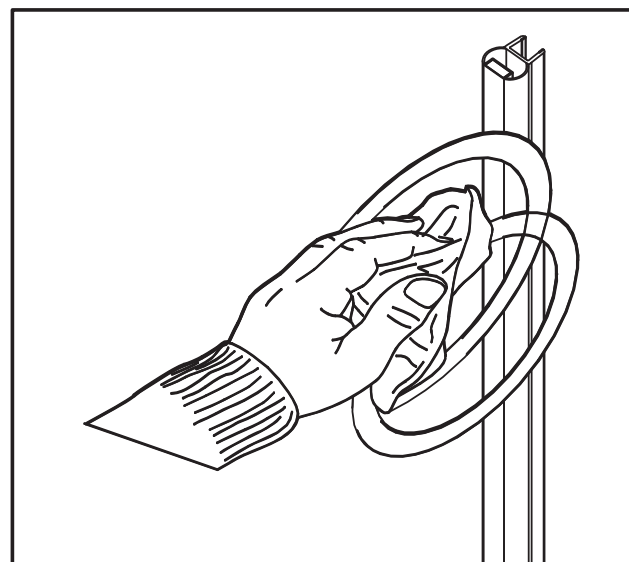
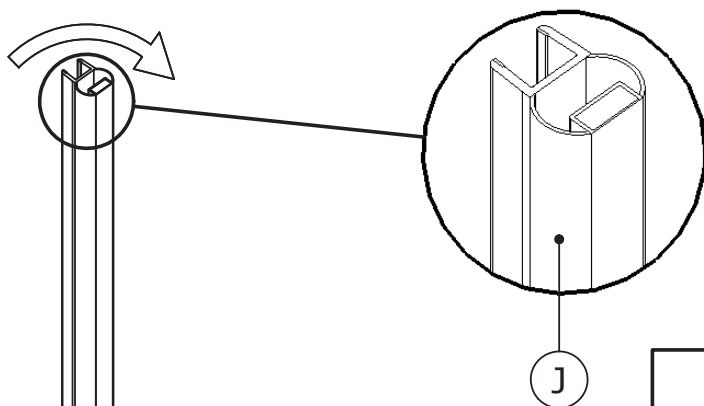
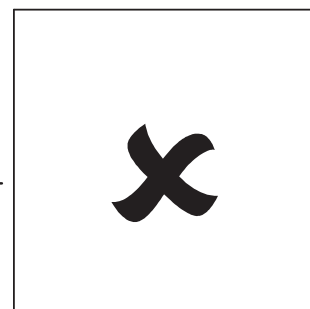
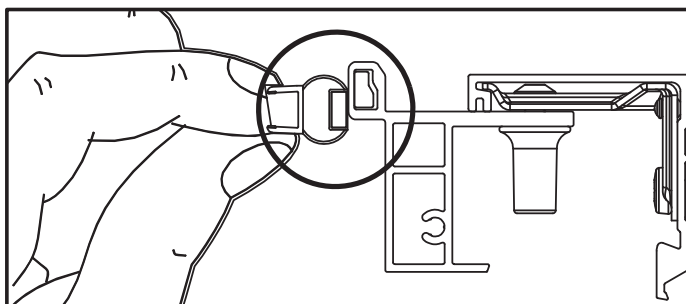
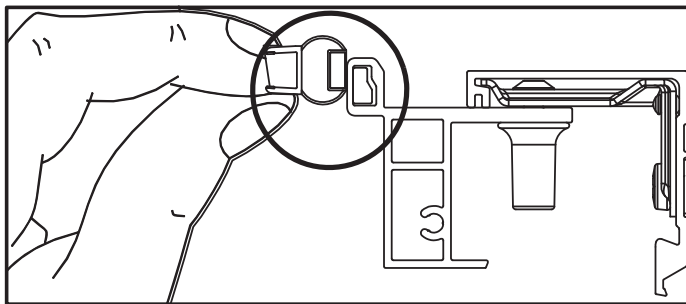
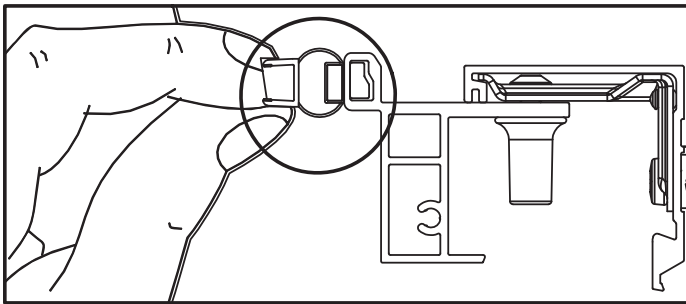

Intérieur - Inside
Interior - Interior - Interno
Binnenkant - Innen

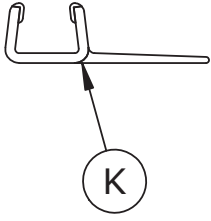

Extérieur - Outside
Externo - Exterior - Esterno
Buitenkant - Außen



Couper (K) en partie haute
Cut (K) at the top
Corte (K) en la parte superior
Corte (K) a parte superior
tagliare (K) in alto
Snijden (K) in het bovenste
Schnitt (K) im Ober

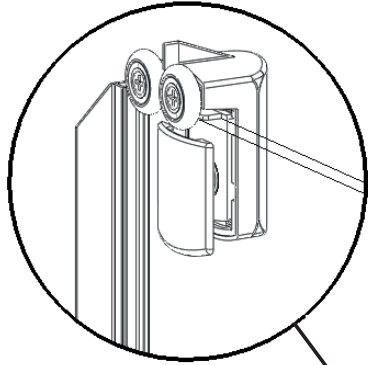

(K)

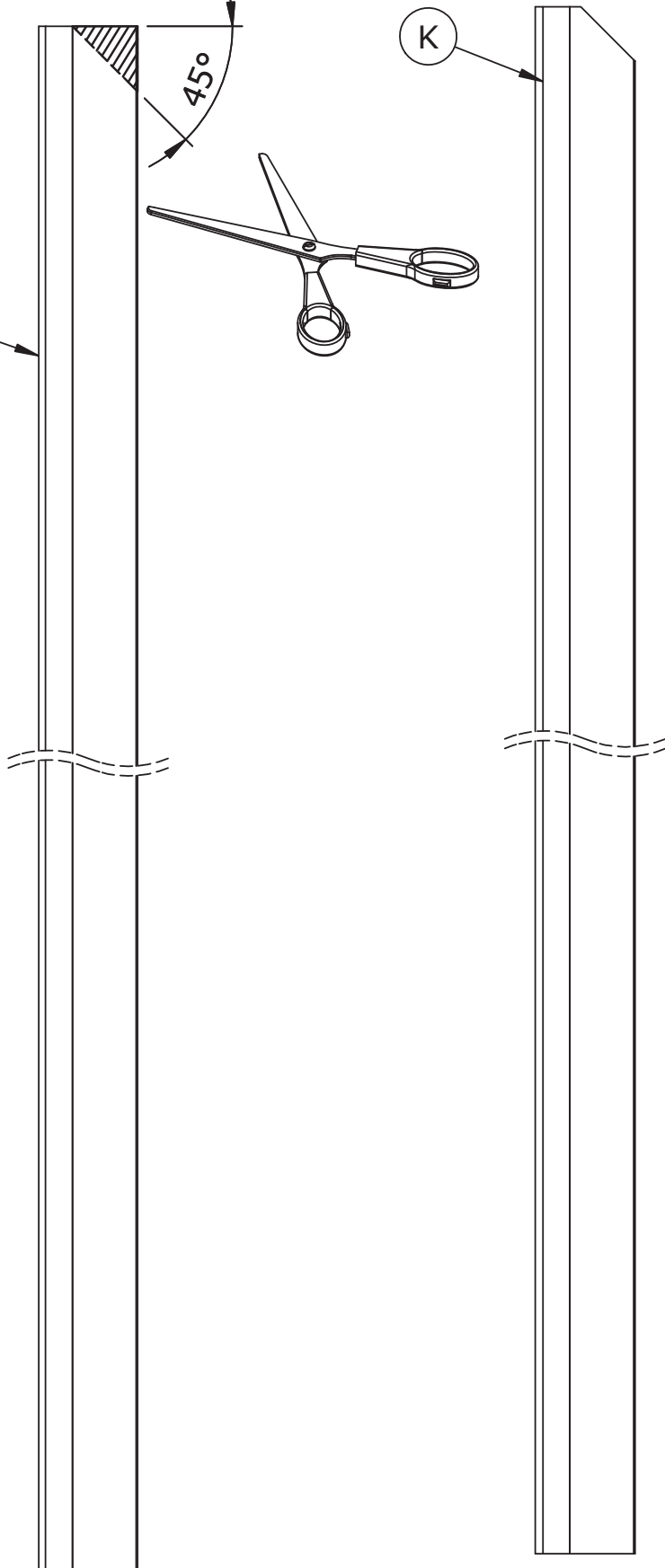

(B)

Extérieur
Outside
Externo
Exterior
Esterno
Buitenkant
Außen

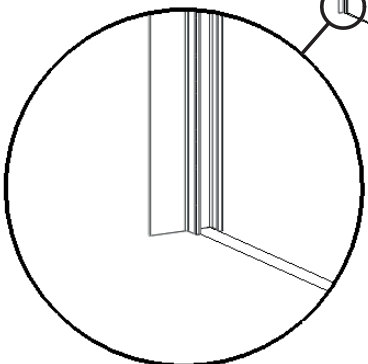

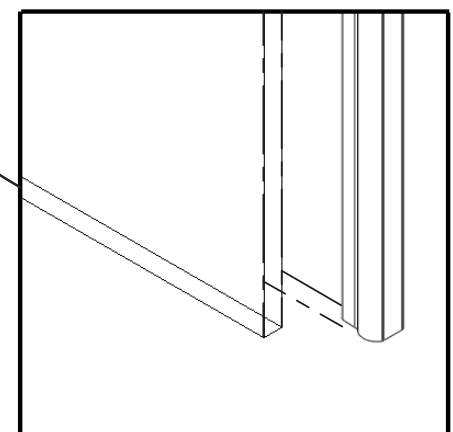
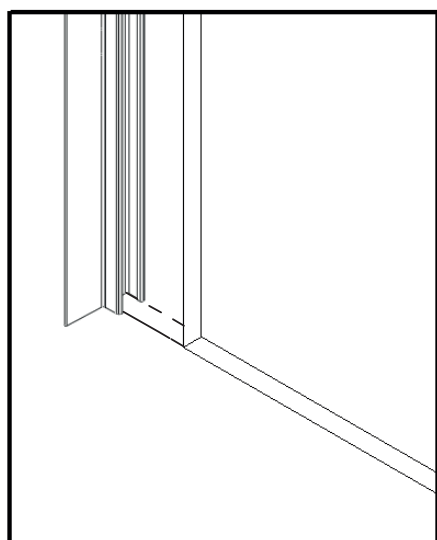
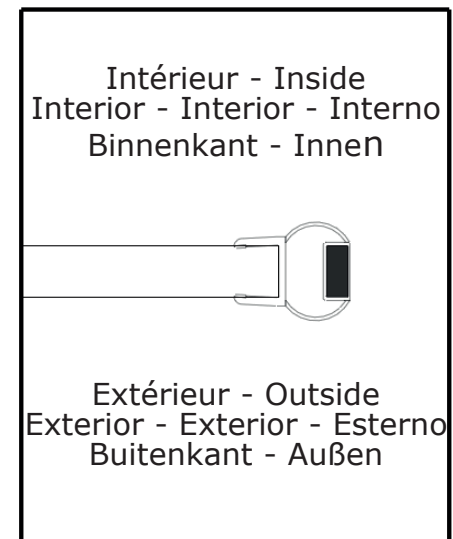
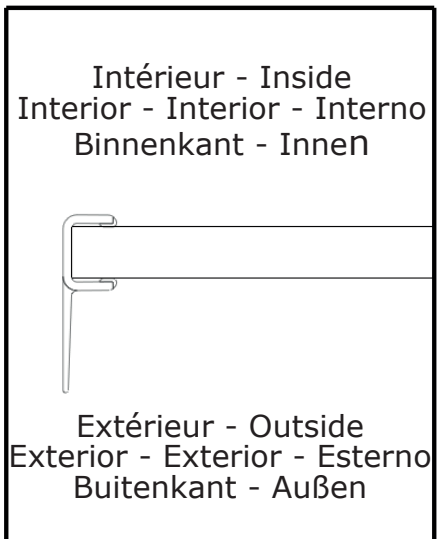
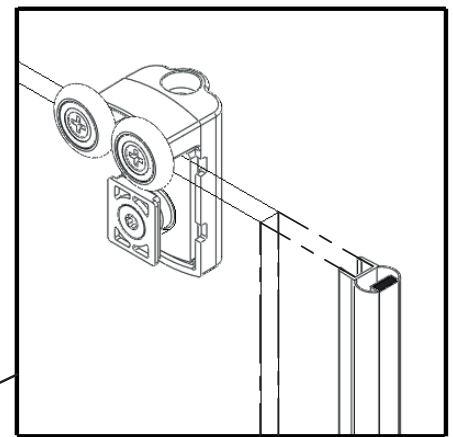
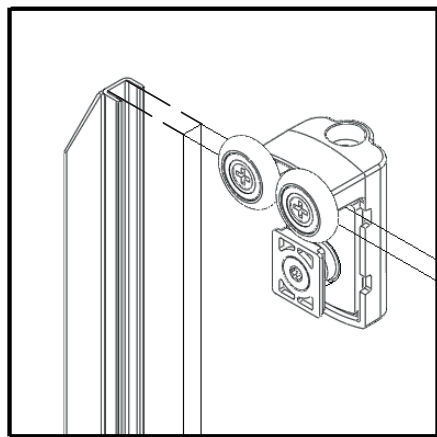

Extérieur - Outside - Exterior
 Esterno - Buitenkant - Außen

Intérieur - Inside - Interior
 Interno - Binnenkant - Innen

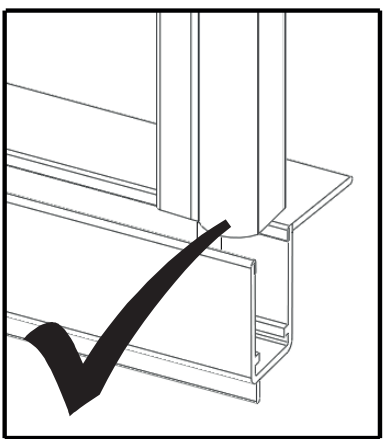
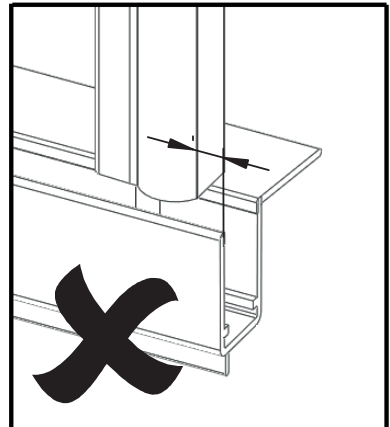
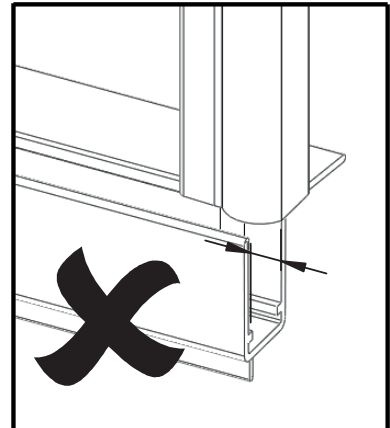
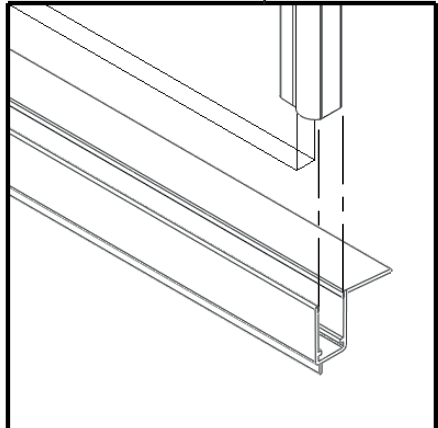
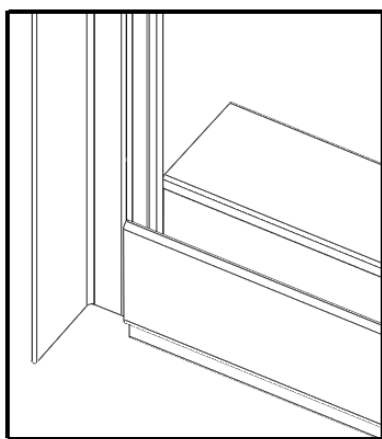
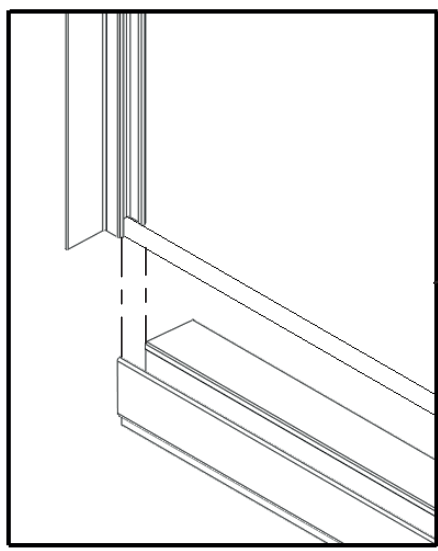
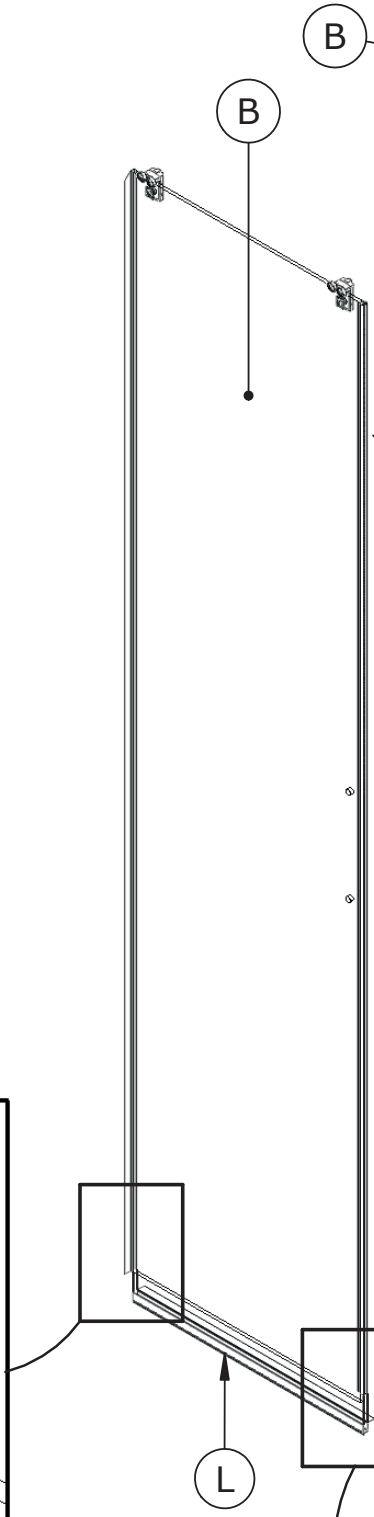
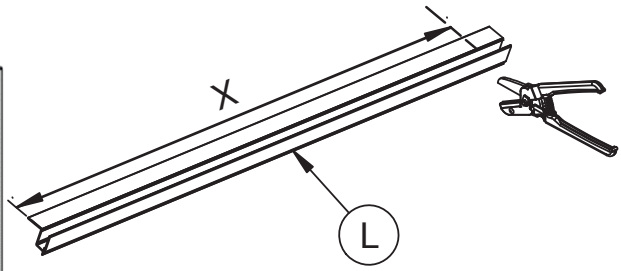
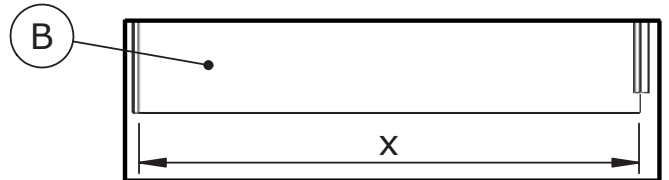

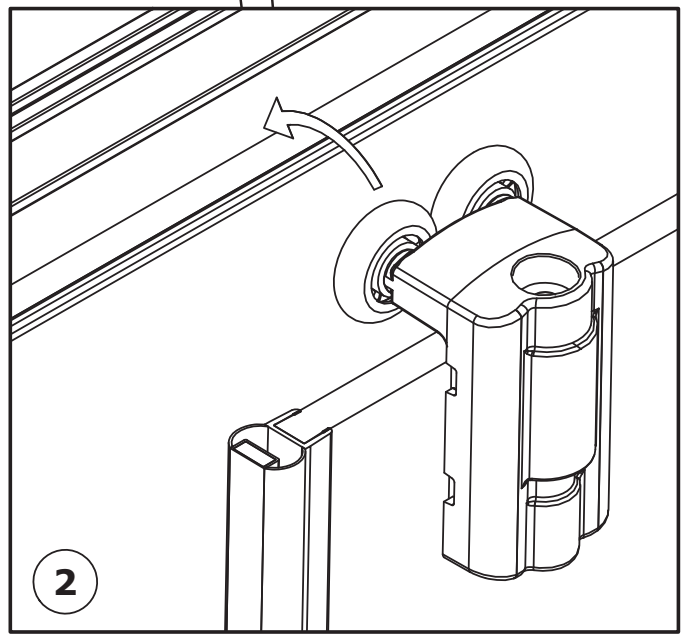
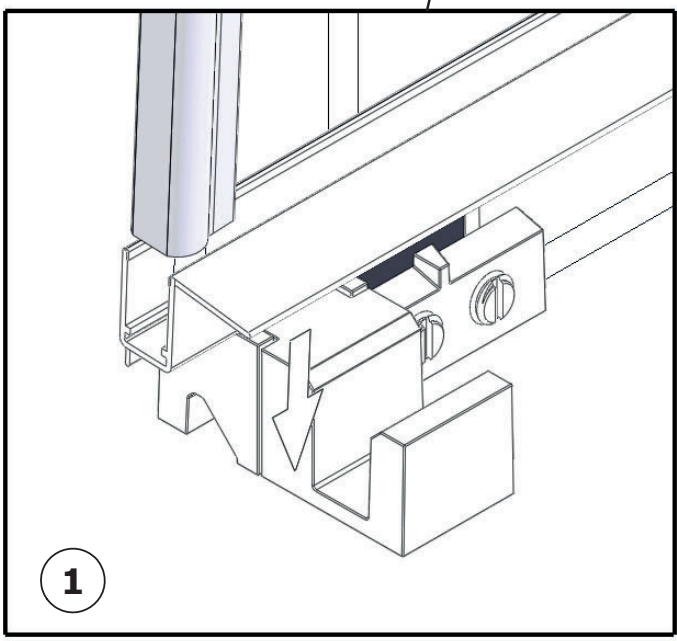
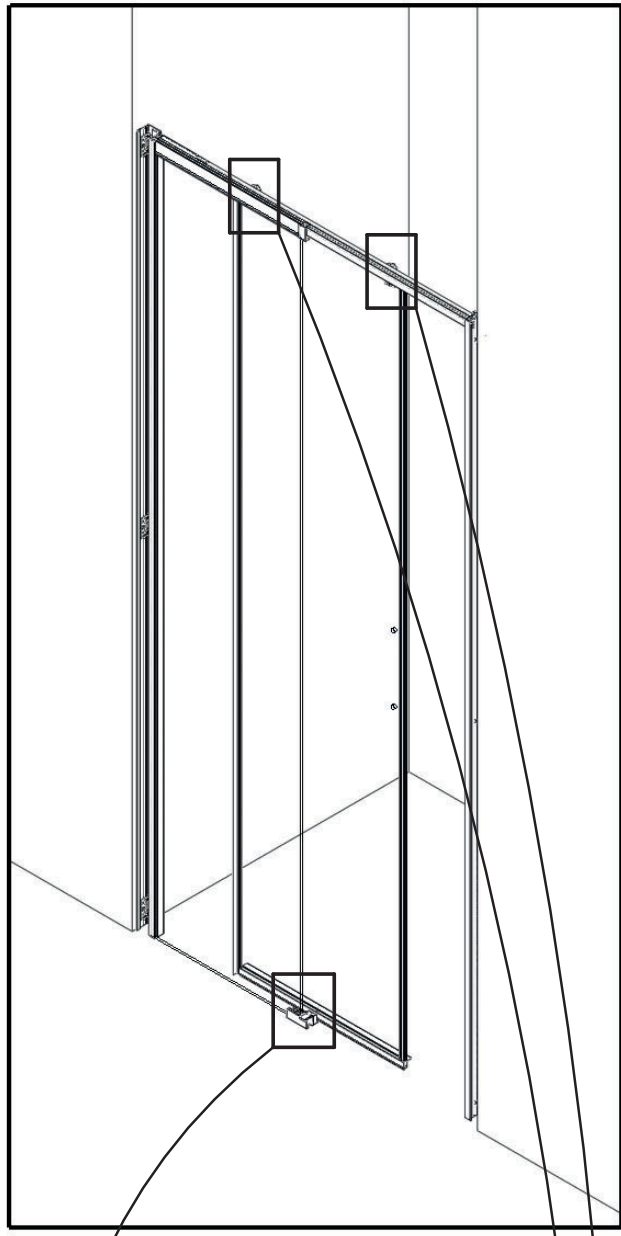

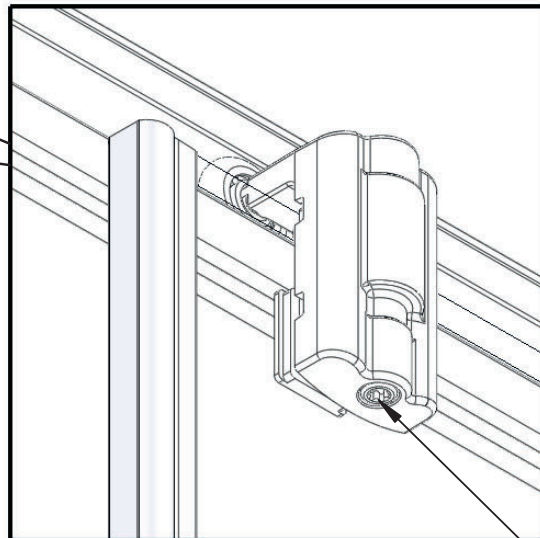

-Régler les portes afin qu'elles soient de niveau

-Adjust the doors so that they are level

-Ajustar las puertas de manera que estén niveladas

-Ajustar as portas de modo a que fiquem niveladas

-Regolare le porte in modo che siano in bolla

-Stel de deuren zodanig af zodat ze waterpas staan

-Türen waagrecht ausrichten

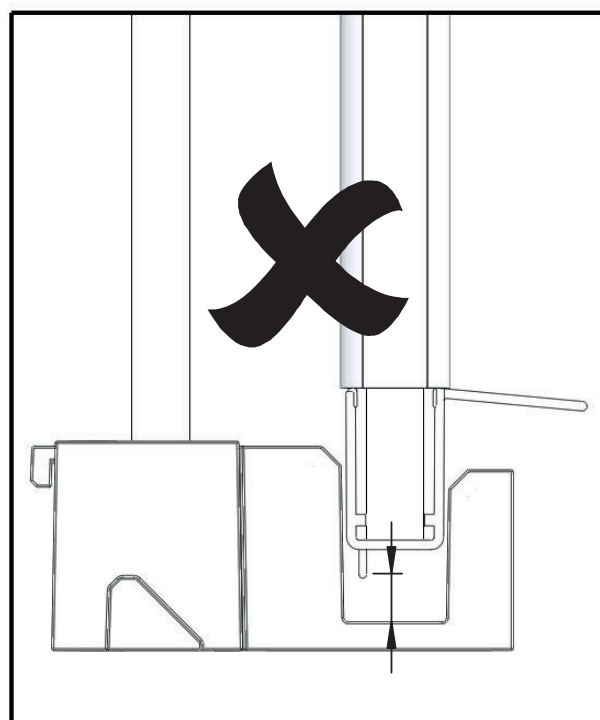
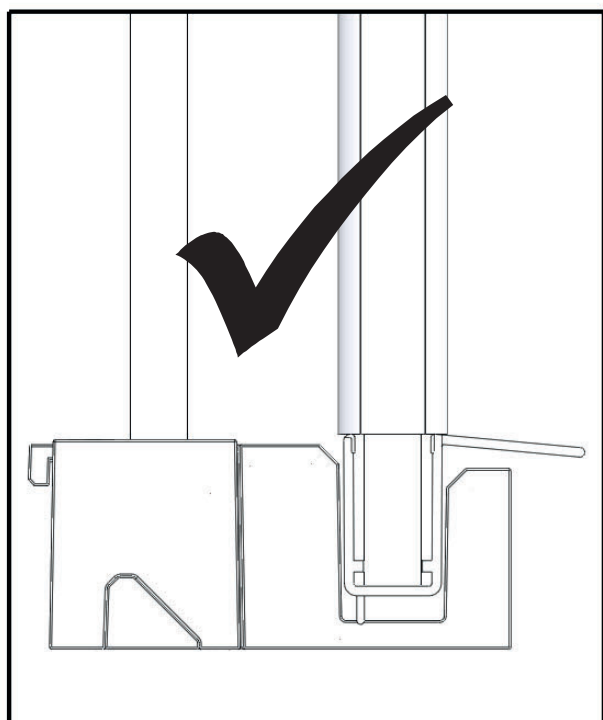

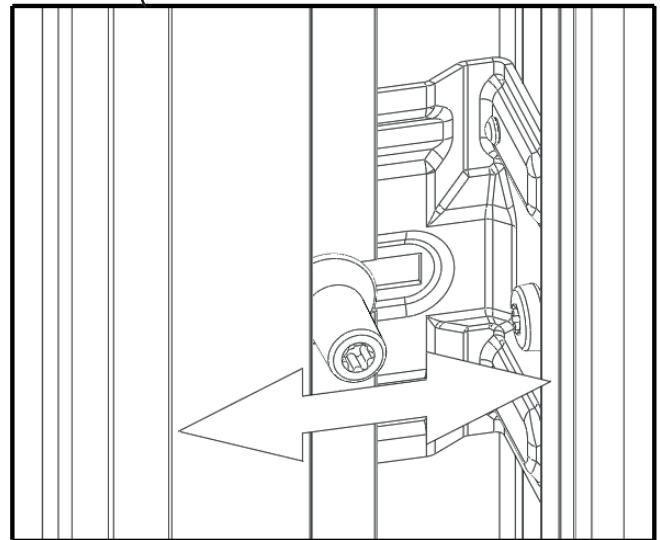
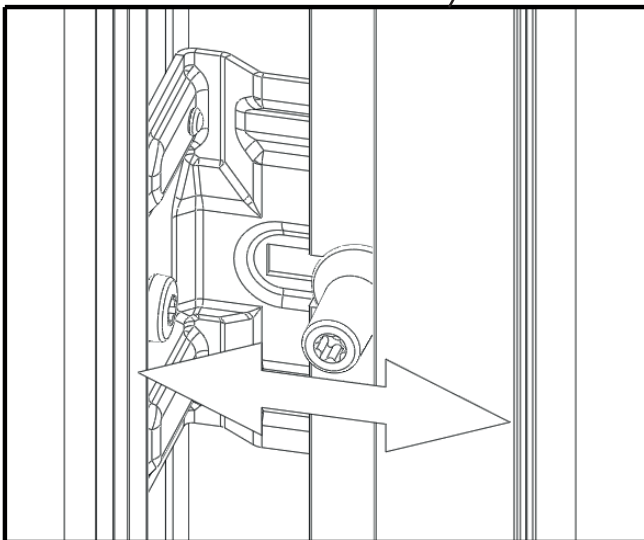
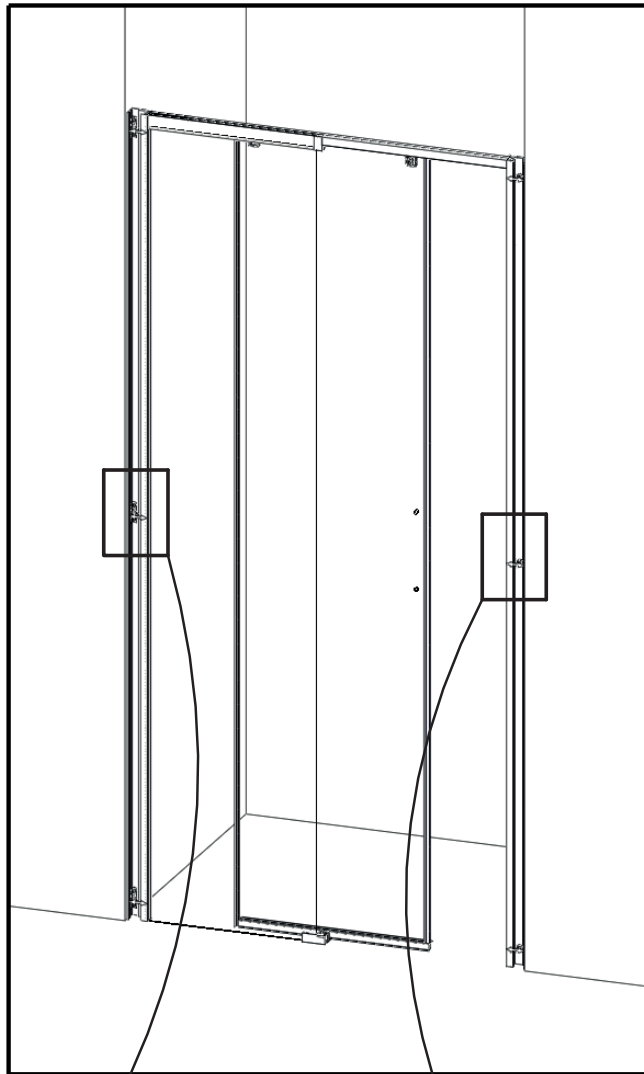

Si nécessaire, desserrer, régler puis resserrer
 If necessary, loosen, adjust and retighten
 Si es necesario, afloje, ajuste y apriete
 Se necessário, desaperte, ajuste e aperte
 Se necesario, allentare, regolare e stringere
 Draai los, indien nodig, stel af en draai vervolgens weer vast
 Falls erforderlich, lösen, einstellen und wieder festziehen

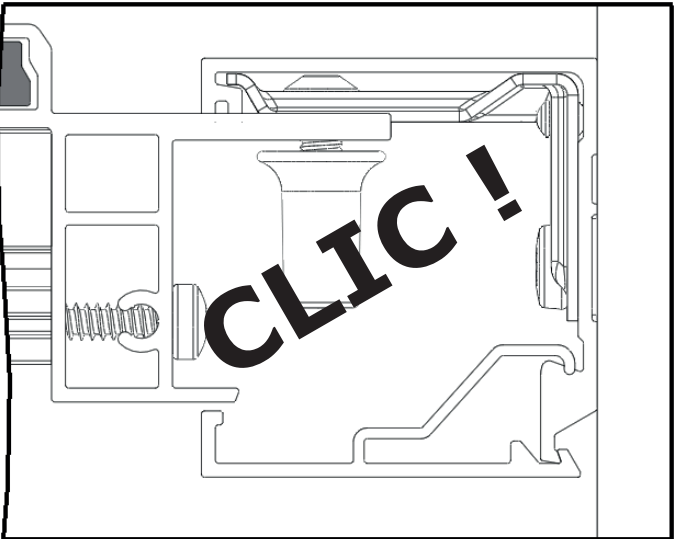
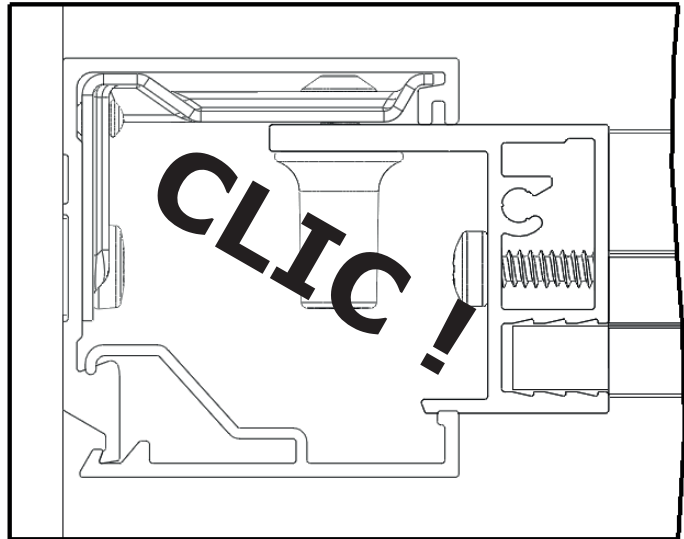
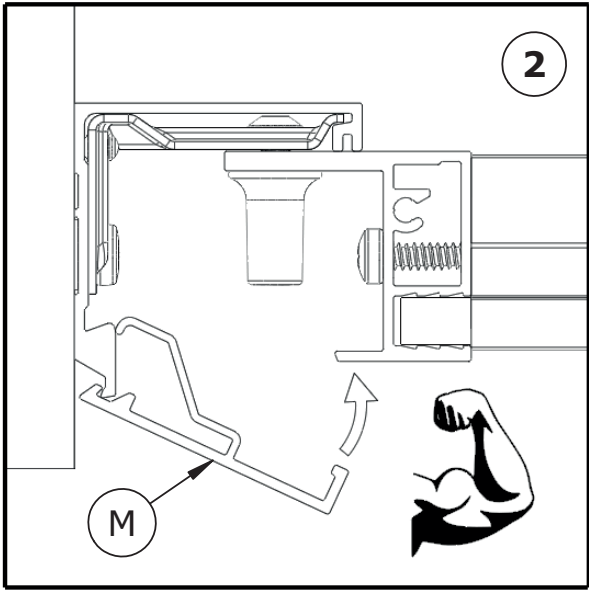
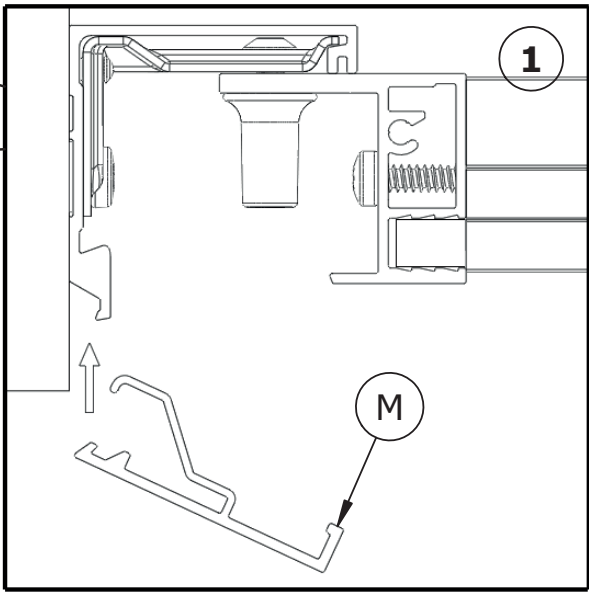
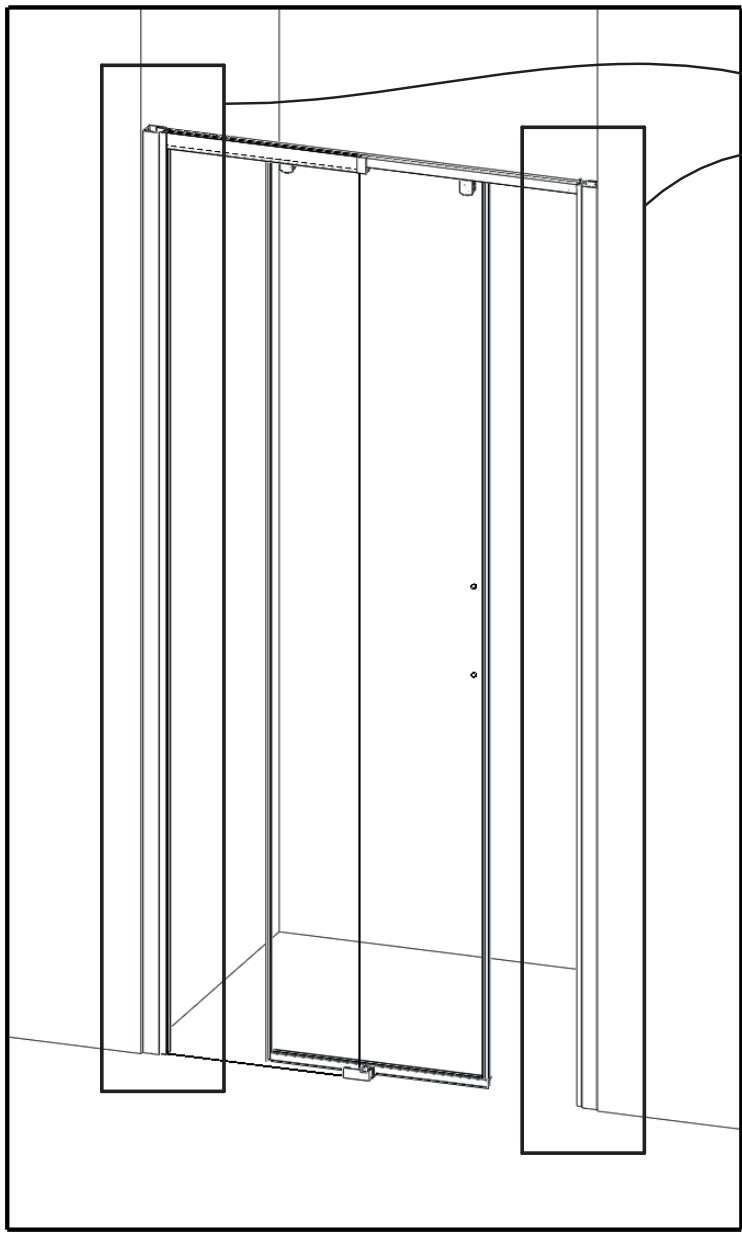

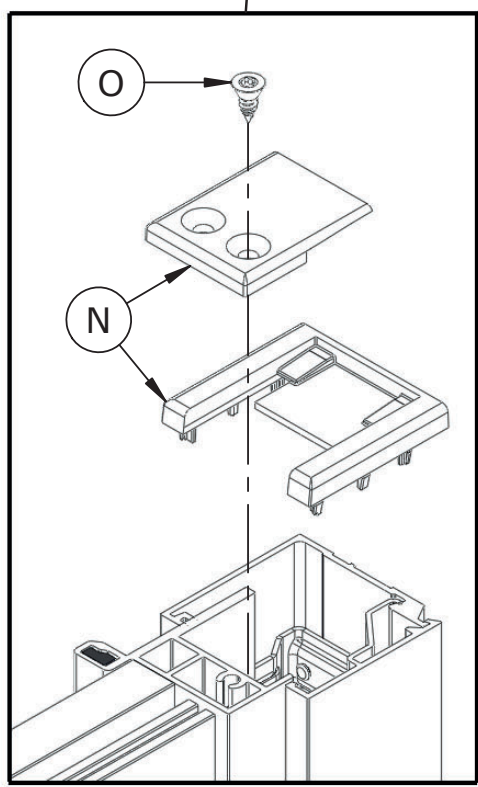
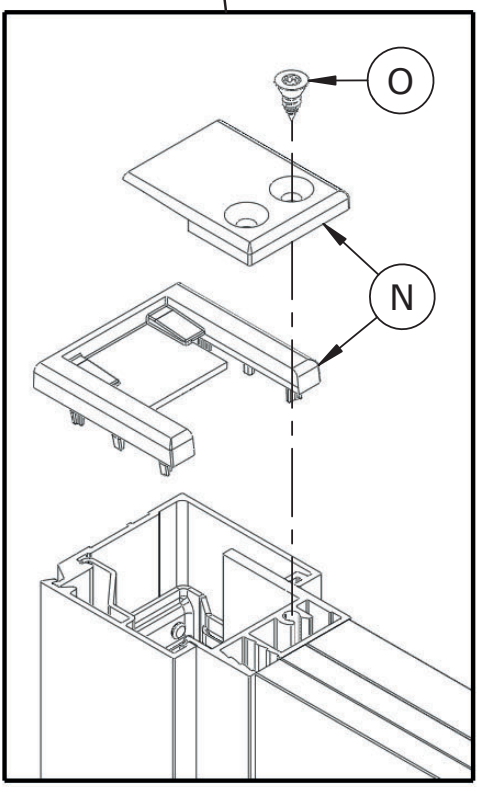
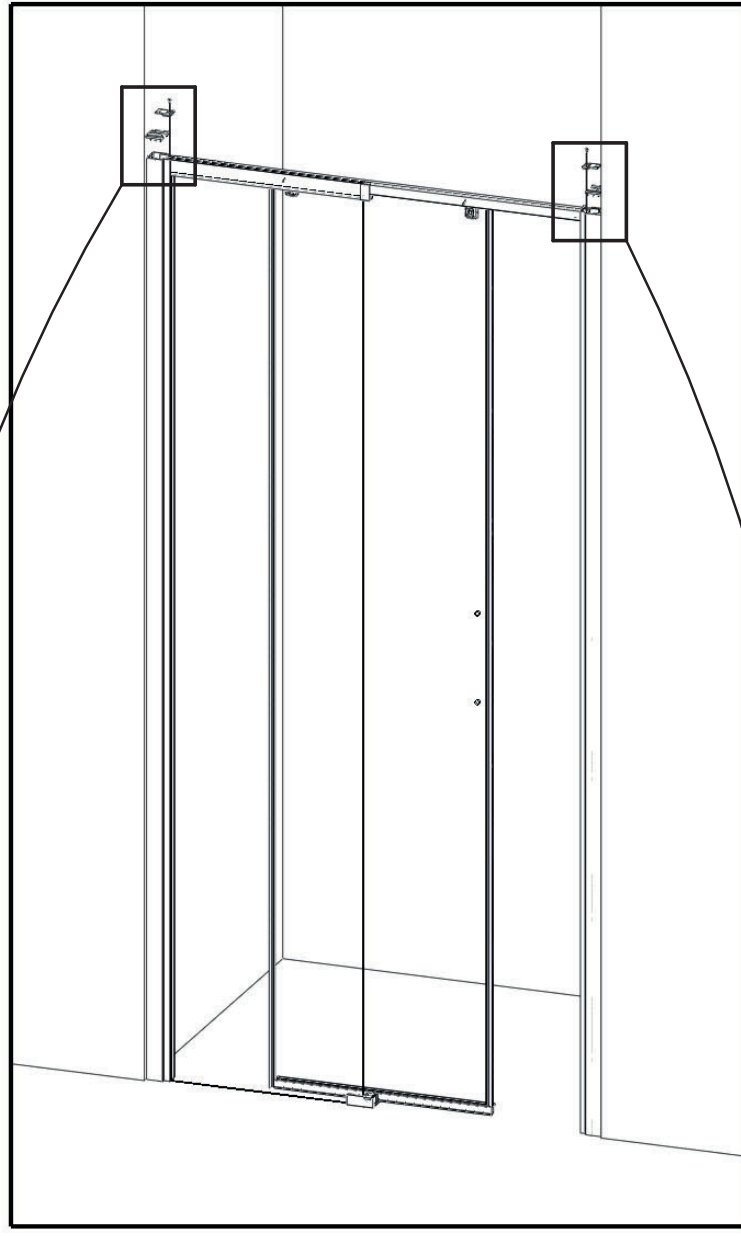

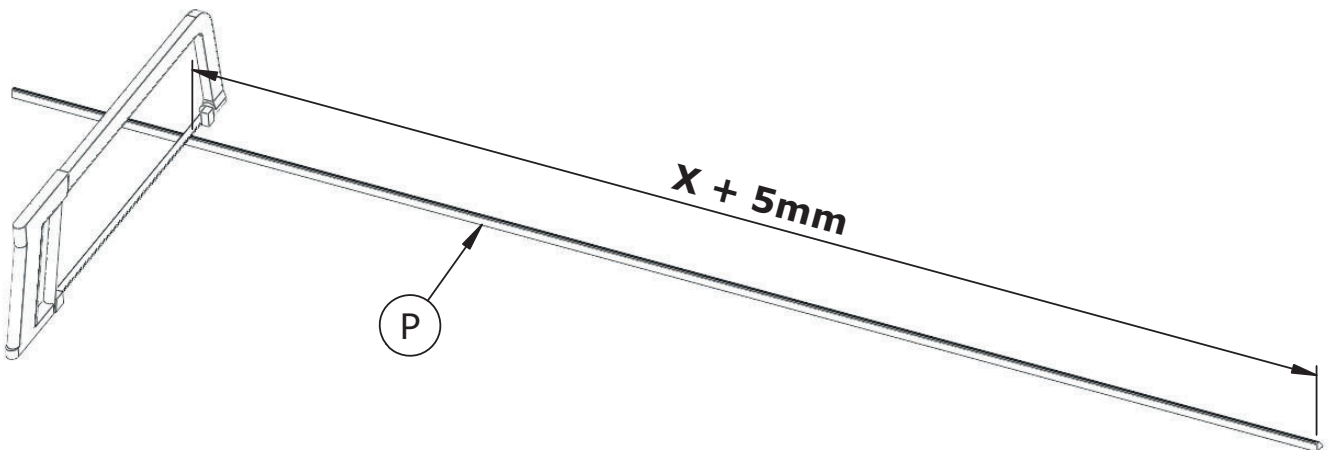
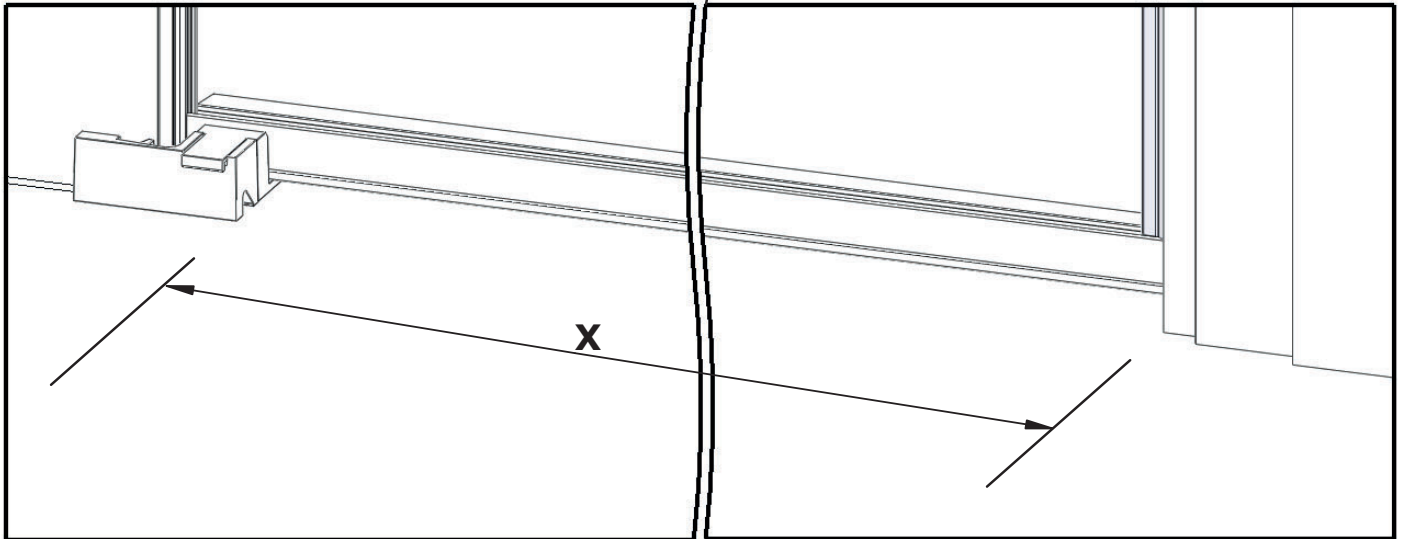
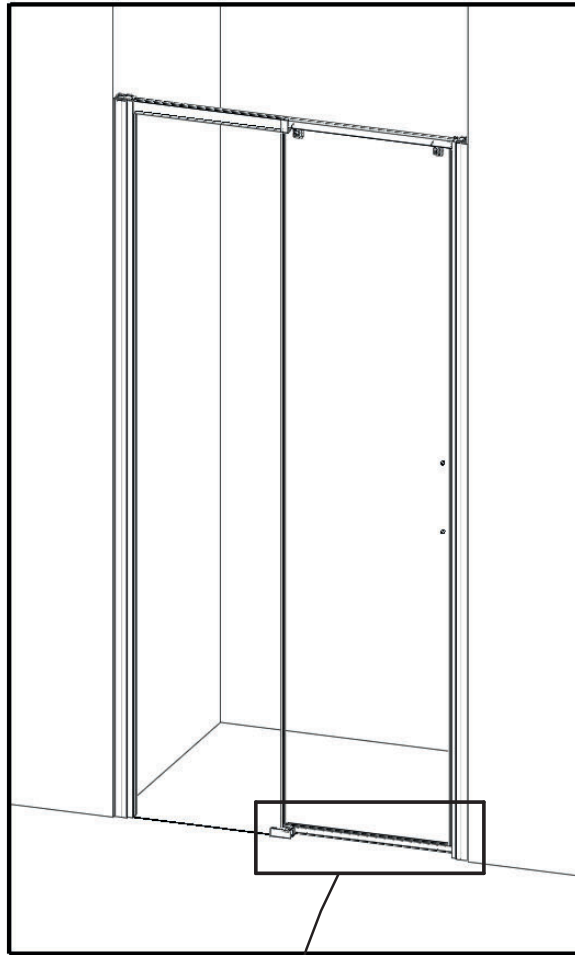

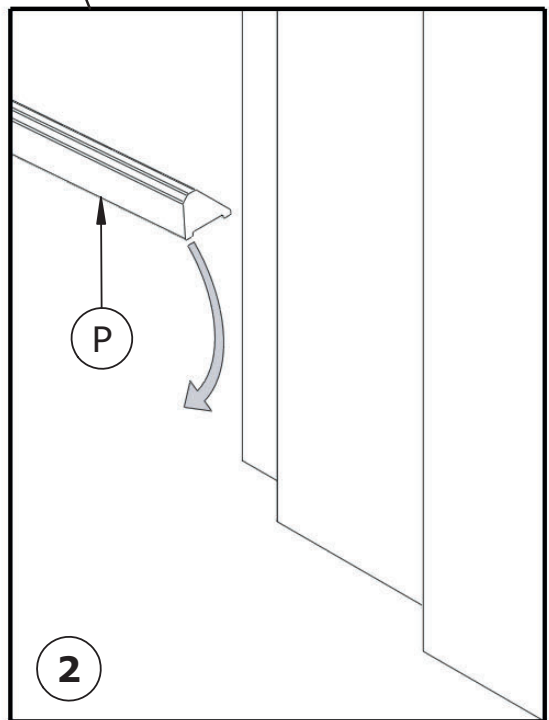
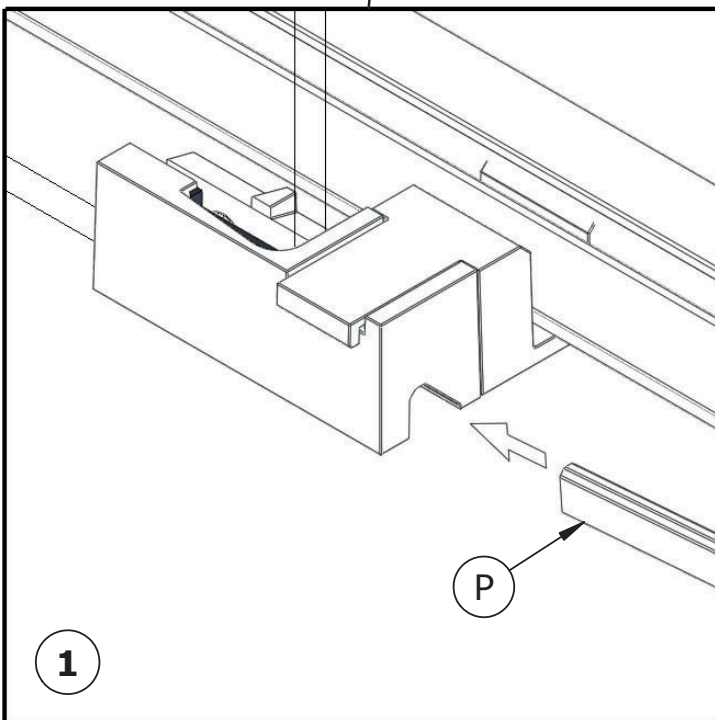
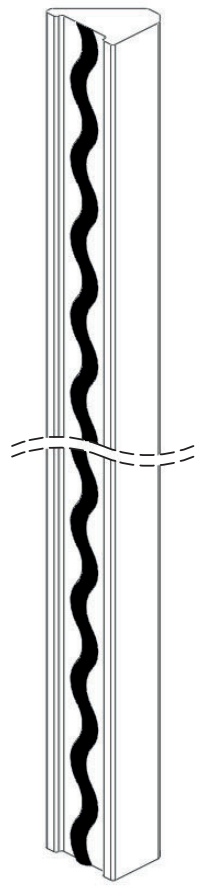
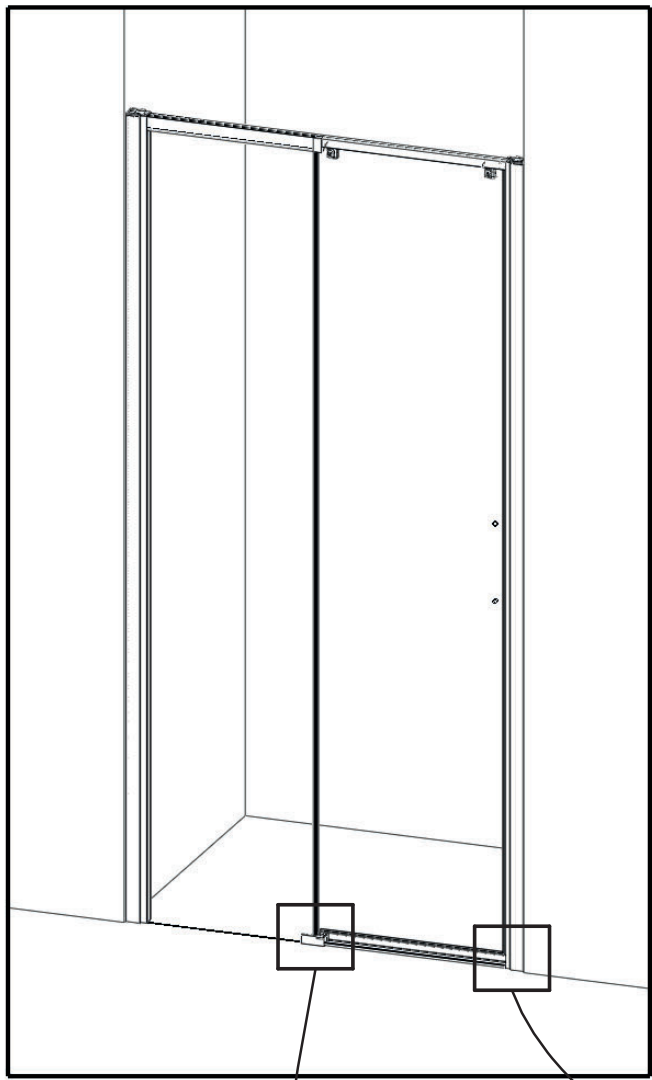

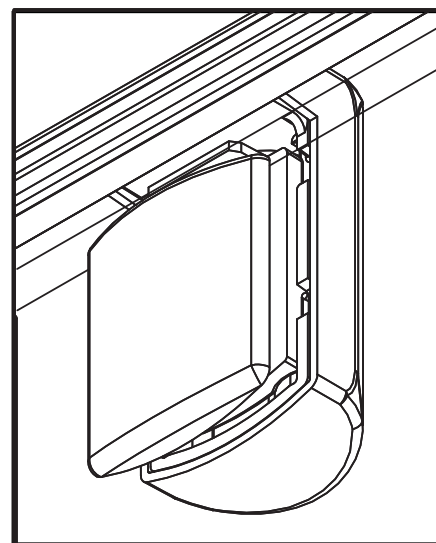
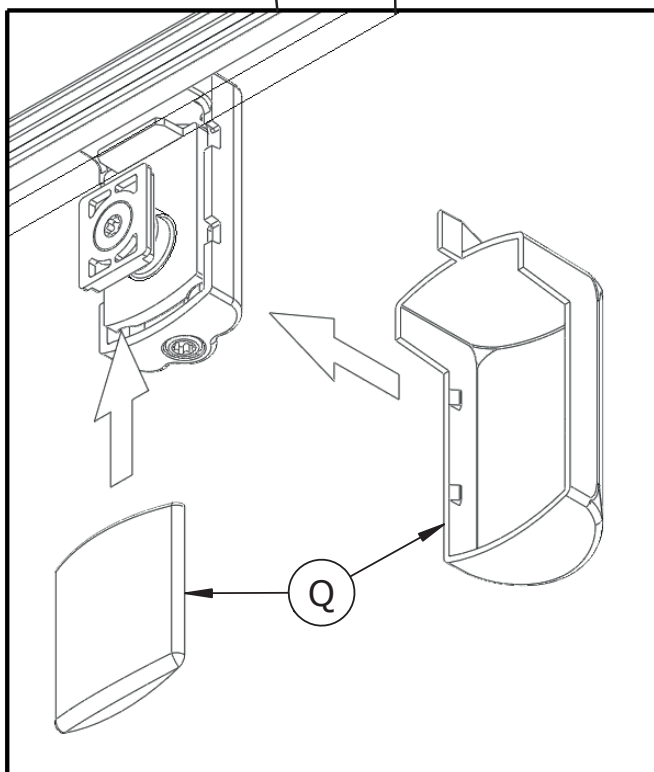
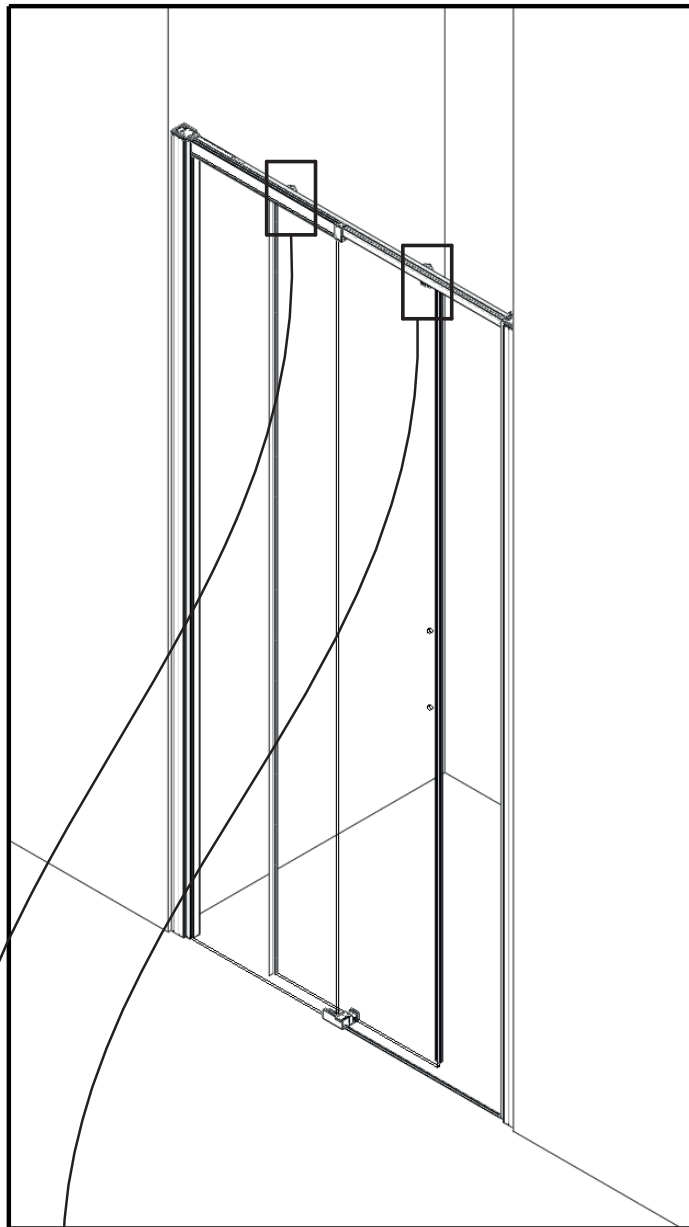

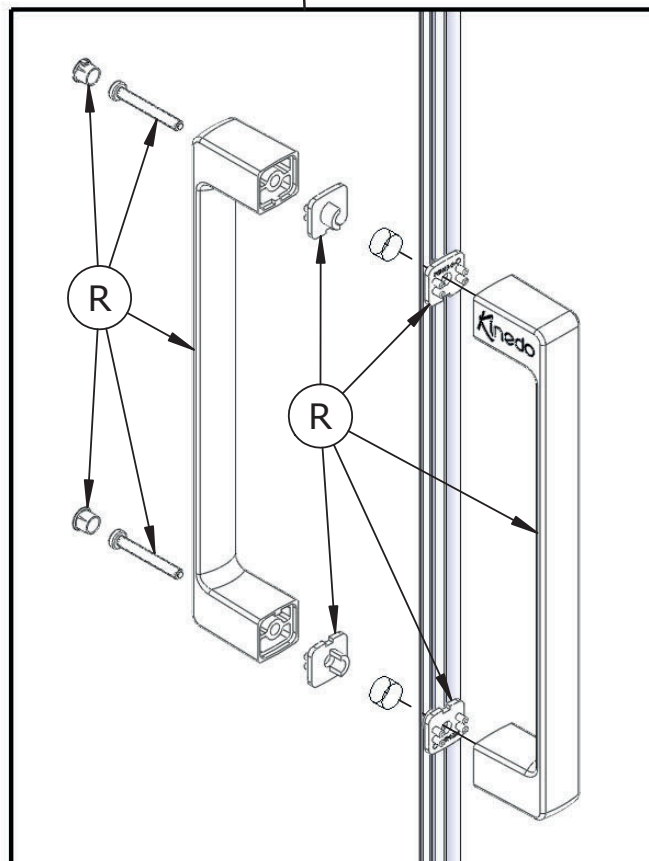
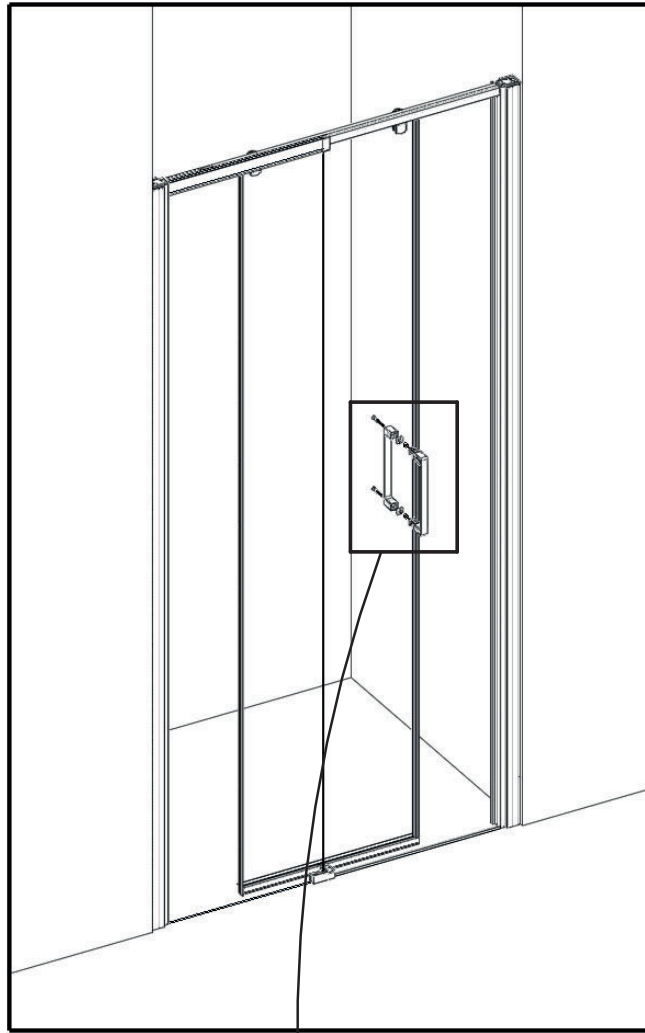

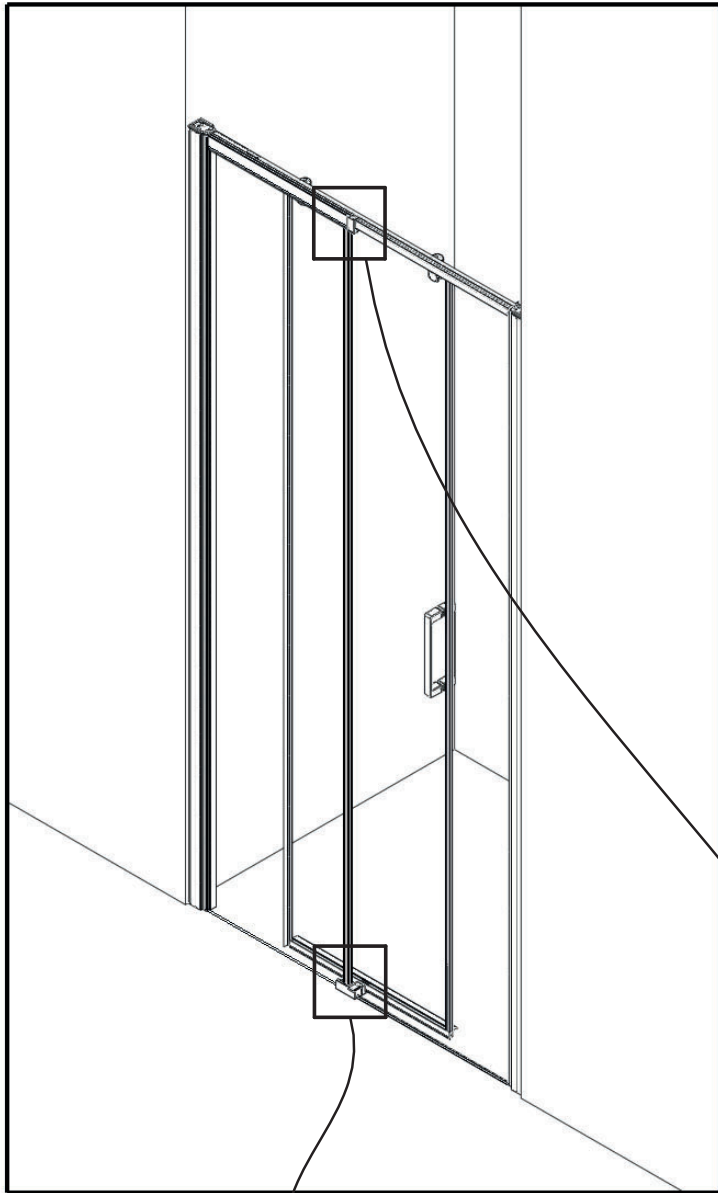



Intérieur - Inside
Interior - Interior - Interno
Binnenkant - Innen

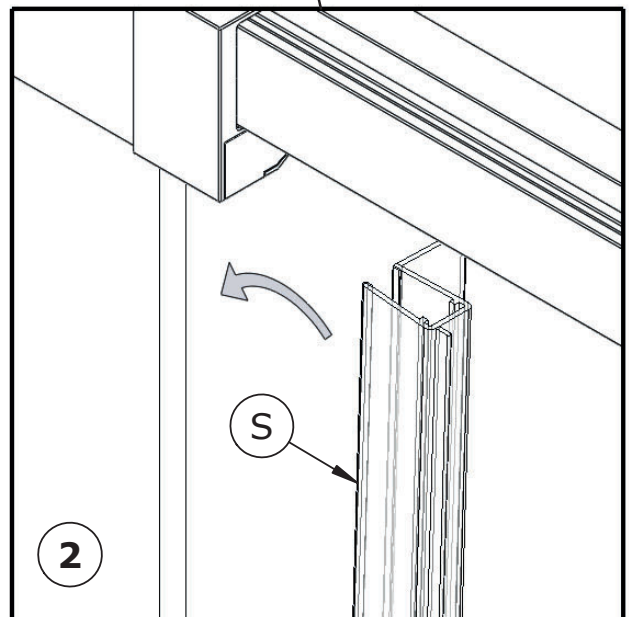
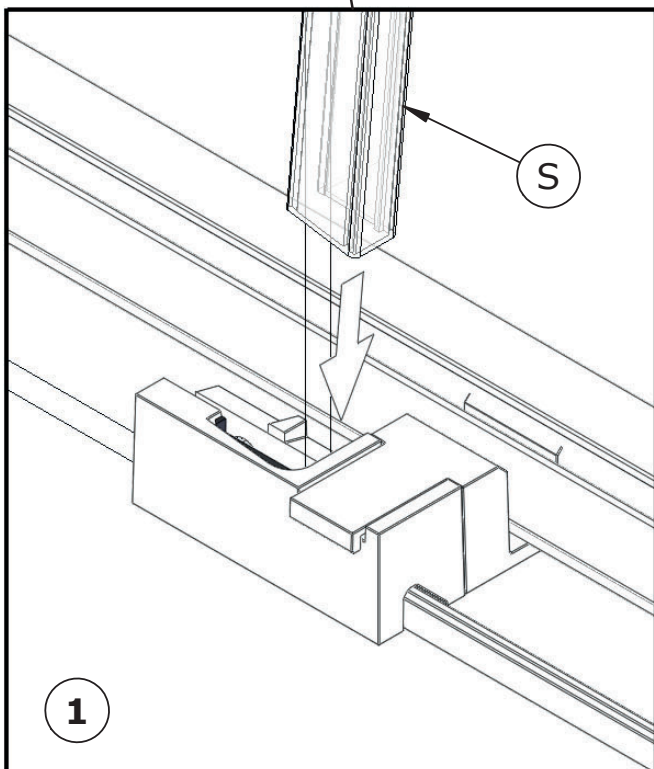

Extérieur - Outside
Exterior - Exterior - Esterno
Buitenkant - Außen

A legend box containing text in three languages (French, English, Italian/German) and a small cross-section diagram of a window frame profile. The diagram shows a horizontal profile with a vertical flange on the right side.

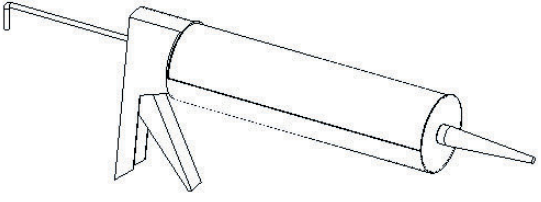

24H

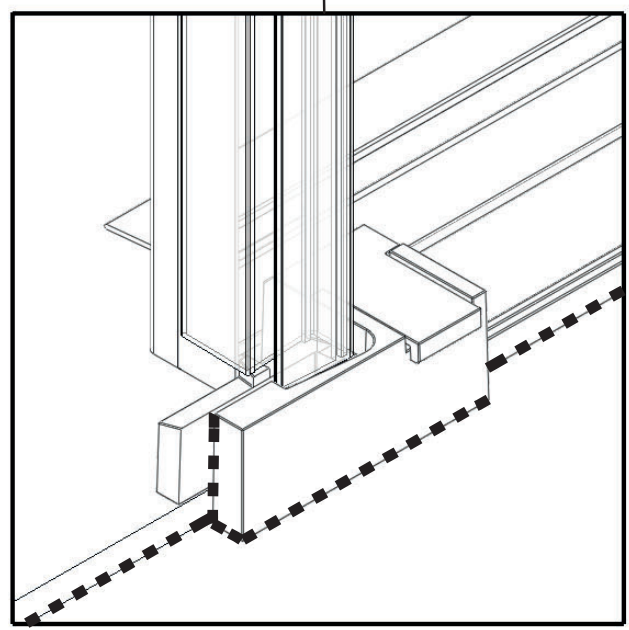
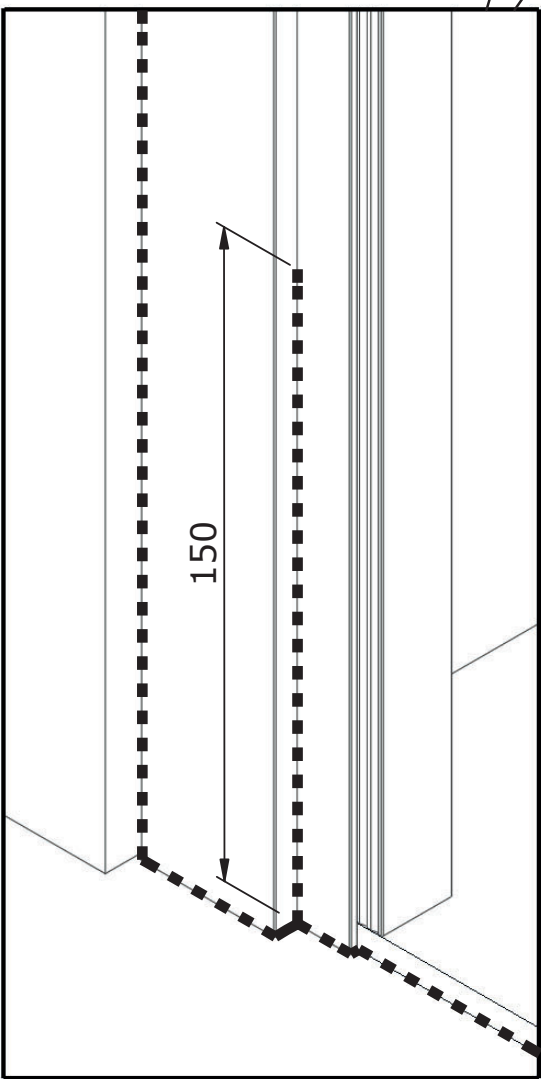
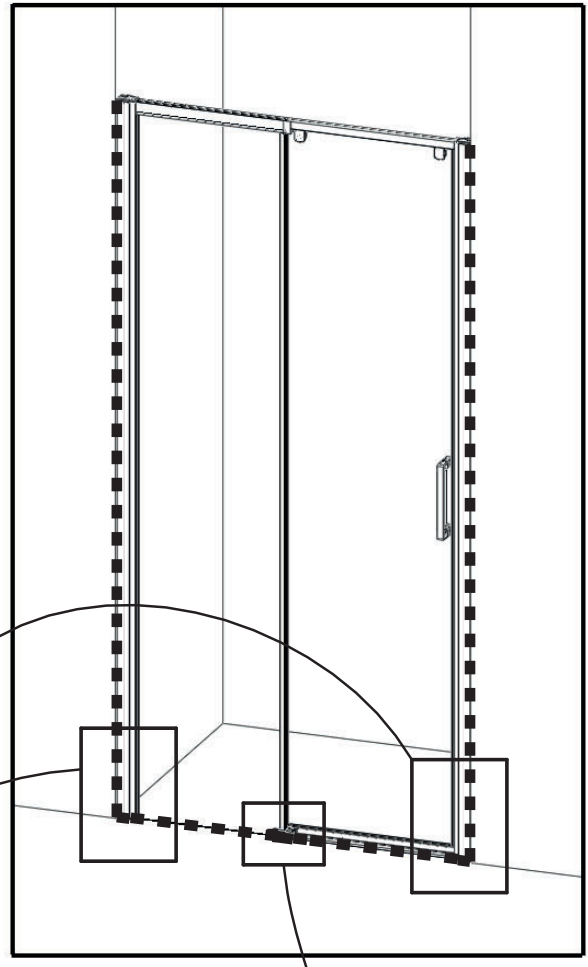



AQUAPRODUCTION, Site industriel,
F - 44680 Chaumes-en-Retz

18

EN 14428

Paroi de douche, fabriquée en verre de silicate
sodo-calcique de sécurité trempé thermiquement

Aptitude au nettoyage : réussite

Résistance à l'impact/propriétés de fragmentation : réussite

Durabilité : réussite



SERVICE APRÈS-VENTE AFTER-SALES SERVICE

FRANCE

+33 (0)2 40 21 29 45

UK

+44 (0)20 8842 0033

IRELAND

+353 04697 33102

DEUTSCHLAND

+49 (0) 6074 / 30928 0

ITALIA

+39 (0382) 6181

ÖSTEREICH

+43 1 710 60 70

SUISSE/SCHWEIZ

+41 (0)32 631 04 74

ESPAÑA

+34 93 544 60 76

NEDERLAND

+31 475 487 100

BELGIQUE/BELGIË

+31 475 487 100

РОССИЯ

+7 495 258-29-51

PORTUGAL

+351 219 112 785