

FAR TOOLS®

FR	Rénovateur extérieur (Notice originale)
EN	Exterior renovator (Original manual translation)
DE	Schleif- und Renoviergerät (Übersetzung aus der Originalanleitung)
ES	Fuera renovador (Traducción del manual de instrucciones originale)
IT	Restauratore di fuori (Traduzione dell'avvertenza originale)
PT	Fora renovador (Tradução do livro de instruções original)
NL	Buiten renovator (Vertaling van de originele instructies)
EL	έξω από ανακαινιστής (Μετάφραση από τις πρωτότυπες οδηγίες)
PL	Poza renowatora (Tłumaczenie z oryginalnej instrukcji)
FI	Ulkopuolella remontoijille (Käännös alkuperäisestä ohjeet)
SV	Utanför renovator (Översättning från originalinstruktioner)
BU	Извън обновител (Превод на оригиналната инструкция)
DA	Udenfor renovator (Oversættelse fra oprindelige brugsanvisning)
RO	În afara renovator (Traducere din instrucțiunile originale)
RU	Вне реставратора (Перевод с оригинальной инструкции)
TU	Yenileyen dışında (Orijinal talimatlar çeviri)
CS	Mimo renovátor (Překlad z originálního návodu)
SK	Mimo renovátor (Preklad z originálneho návodu)
HE	תוירוקמ תוארומה סוגרת) קינצופיש יוץחמ
AR	ةيلصأال تاميلعتلأا نم قمعرتلأا (حلصم جراخ)
HU	Kívül renovator (Fordítás az eredeti utasítások)
SL	Zunaj Obnovilac (Prevod iz izvirnih navodil)
ET	Õues renovator (Tõlge originaal juhiseid)
LV	Ārpus atjaunotājs (Tulkojumā no instrukcijas oriģinālvalodā)
LT	Už Restorer (Vertimas iš originalių instrukcijas)
HR	Vanjski renovator (Prijevod prema originalne upute)



REX200
Professional Machine



© FAR GROUP EUROPE



115015-D-20221025

fartools.com

FIG. A**FIG. C**

FIG. D

01



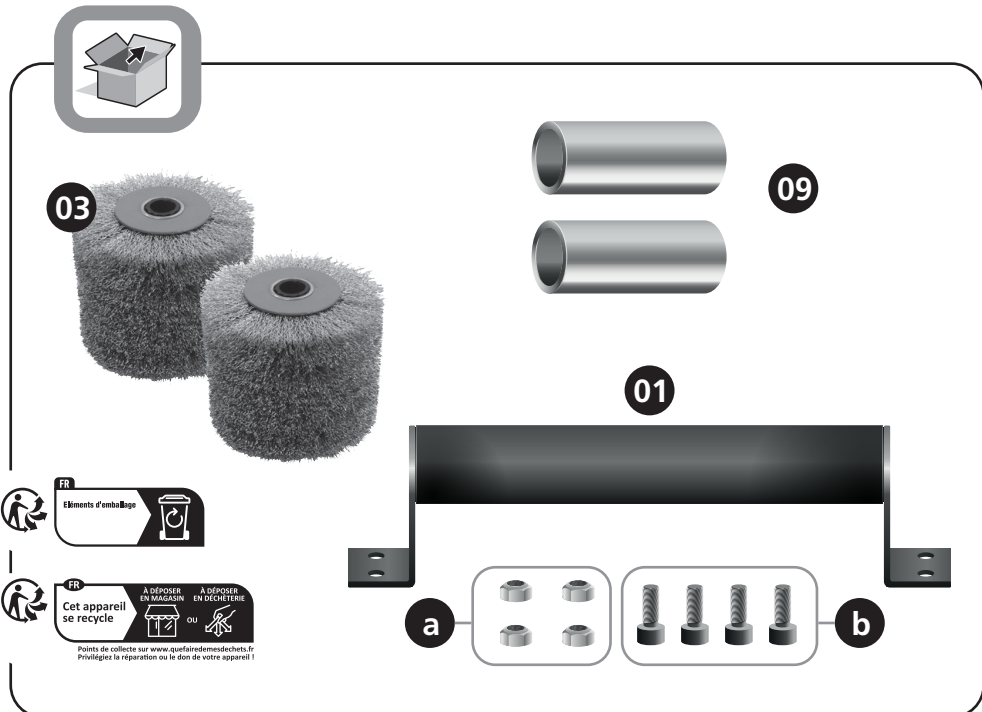
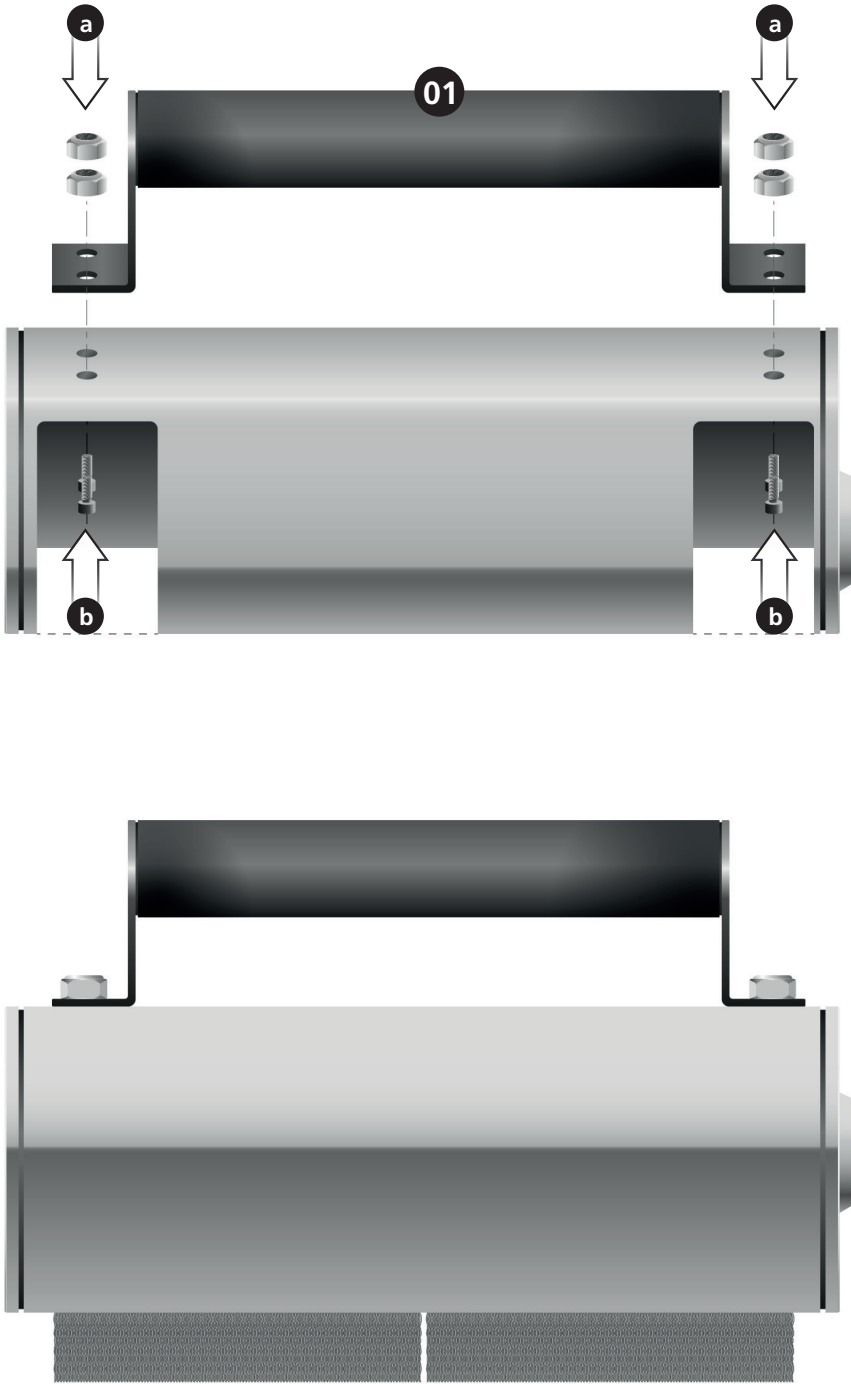
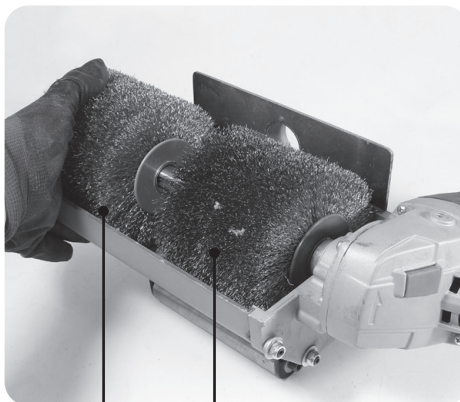
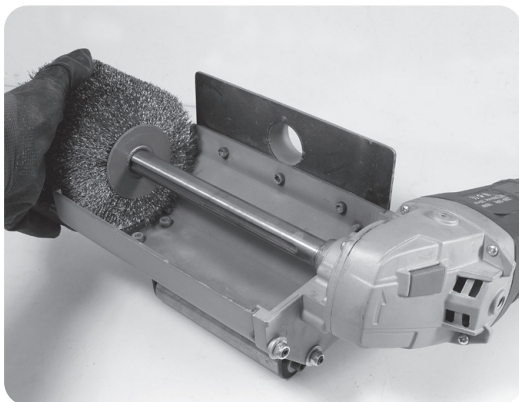
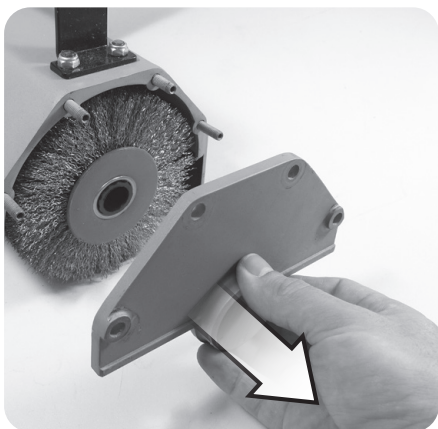
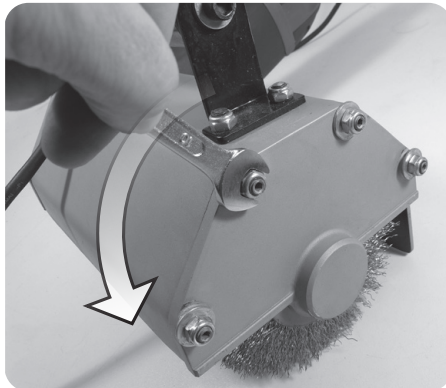

110885 :
Brosse fil laitonée 0,3 mm (x2)
Staalborstel messing 0,3 mm (x2)
0,3 mm cepillo de alambre de latón (x2)
0,3 milimetros escova de arame de bronze (x2)
0,3 millimetri spazzola metallica di ottone (x2)
0.3 mm brass wire brush (x2)

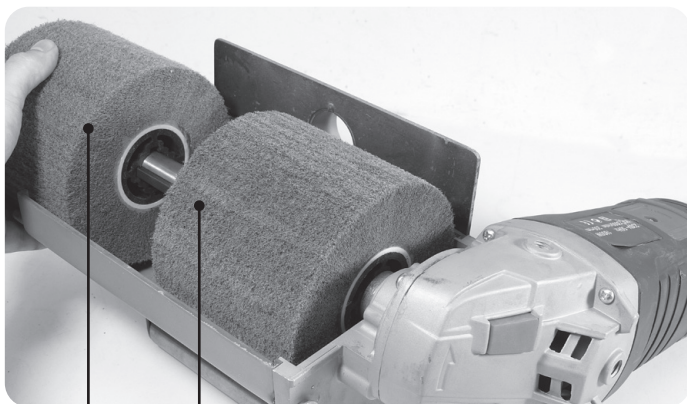

110873 :
Brosse fibre synthétique (x2)
Synthetische vezel penseel (x2)
Pincel de fibra sintética (x2)
Escova de fibra sintética (x2)
Pennello in fibra sintetica (x2)
Synthetic fiber brush (x2)

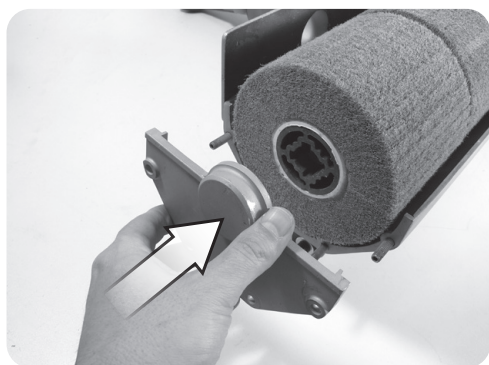



11 x2



A

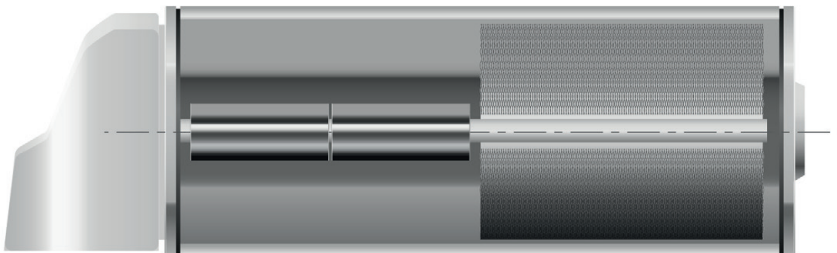

B

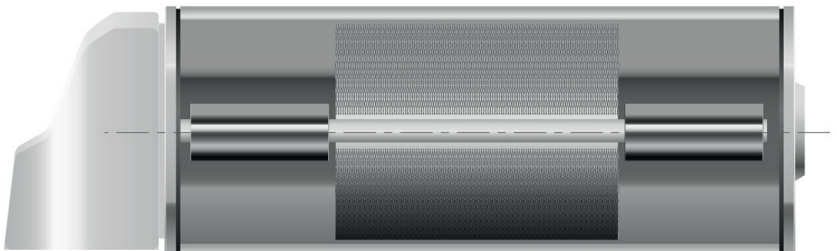

C

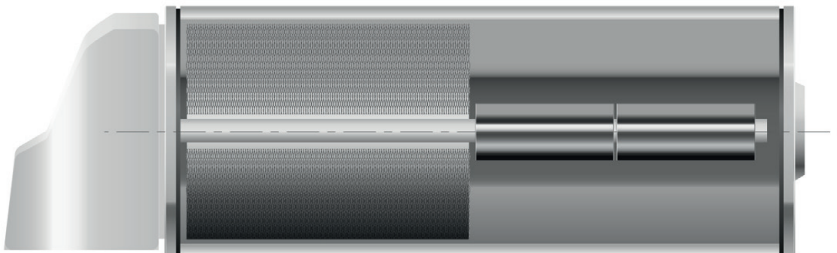

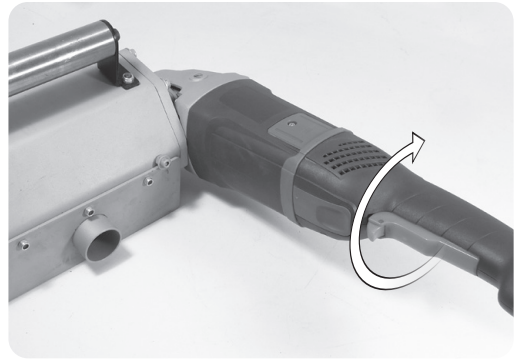
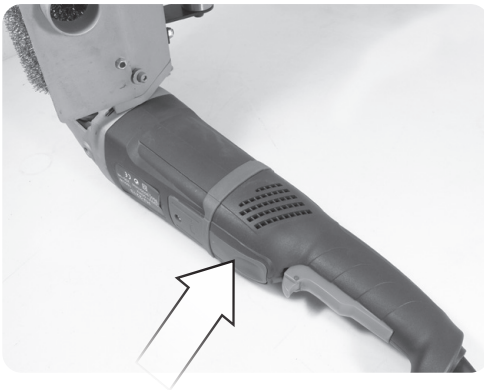
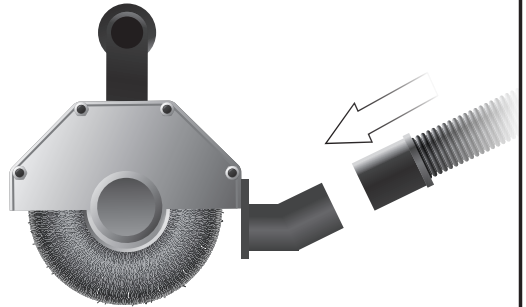
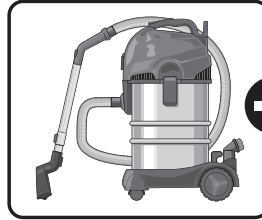

05

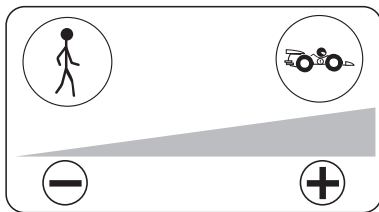

900 - 3200.min⁻¹

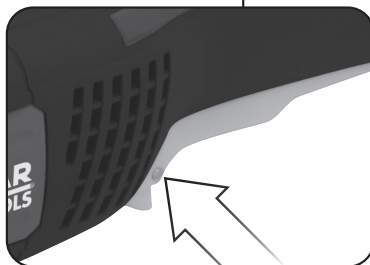

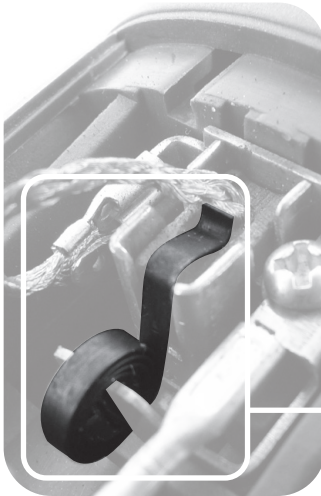
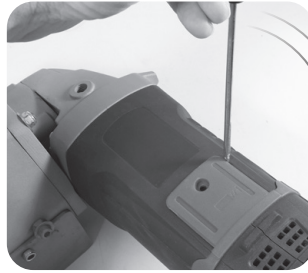
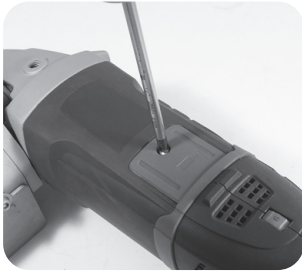

Retirer la lame du ressort de maintien
Verwijder de borgveer mes
Retire la hoja de resorte de retención
Remove a lâmina de mola de retenção
Rimuovere la lama molla di ritegno
Remove the retaining spring blade

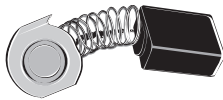
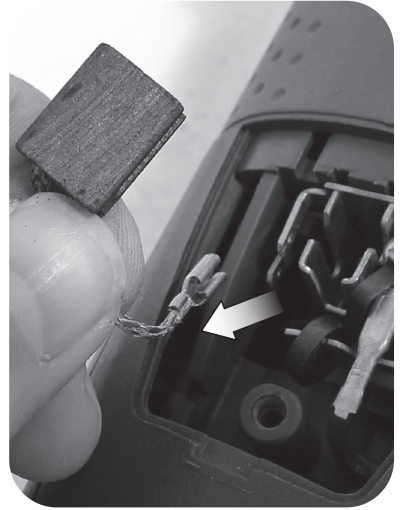
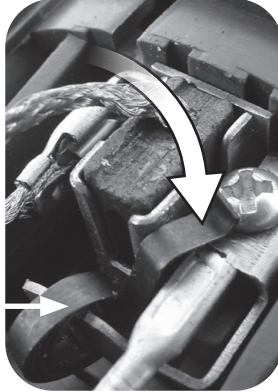



110873



110872

110886



110871

110885



110874

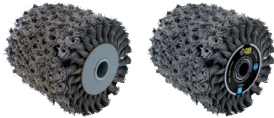

110866

110884



110867



110868







110869





Précaution ! Stockage au sec et à l'abri de la lumière !
Pozor! Shranjevanje v suhem in zaščiteno pred svetlobo!
¡Precaución! Almacenamiento en seco y protegido de la luz!
Cuidado! Armazenamento em seco e protegido da luz!
Attenzione! Stoccaggio in luogo asciutto e al riparo dalla luce!
Caution! Storage in dry and protected from light!

	<p>Tension et fréquence assignée: Nominal frequency and power: Spannung und Frequenz: Tensión y frecuencia fijada: Tensione e frequenza assegnata: Tensão e frequência fixa: Aangewezen spanning en frequentie: Ονομαστική τάση και συχνότητα: Napięcie i częstotliwość przydzielona: Jännite ja määrittäty taajuus: Angiven spänning och frekvens: Anført spænding og frekvens: Tensiune și frecvență de lucru:</p>	<p>Заданное напряжение и частота: Tahsis gerilimi ve frekansı: Stanovené napětí a frekvence: Stanovené napätie a frekvencia: מחאת ותדר מוקצב الفلطية والذبيبة المبرمجة. Névleges feszültség és frekvencia: Napetost in določena frekvenca: Консумирано напрежение и честота : Määratud pinge ja sagedus Nustatyta įtampa ir dažnis Noteiktais spriegums un frekvence.</p>	230 V ~ 50 Hz
	<p>Puissance assignée: Nominal power: Leerlaufdrehzahl: Potencia fijada: Potenza assegnata: Potência assinada: Onbelast toerental: Ονομαστική ισχύς : Prędkość na biegu jałowym: Teho: Angiven effekt: Anført styrke: Putere de lucru:</p>	<p>Заданная мощность: Tahsis edilen güç: Stanovený příkon: Predpísaný výkon: כוח מוקצב القدرة المبرمجة. Névleges teljesítmény : Določena jakost: Консумирана мощност: Määratud võimsus. Nustatyta galia Noteiktā jauda</p>	1800 W
	<p>Vitesse à vide: No-load speed: Drehzahl unbelastet: Velocidad vacía: Velocità a vuoto: Velocidade no vácuo: Leerlaufdrehzahl: Ταχύτητα στο κενό: Prędkość bez bciążenia: Tyhjääyntinopeus Tomgångshastighet: Hastighed i ubelastet tilstand: Viteza în gol:</p>	<p>Скорость вращения на холостом ходу: Boşalma hızı: Rychlost naprázdno: Rýchlost pri chode naprázdno: מהירות ריק. السرعة على الفارغ. Üres sebesség: Prosti tek: Скорост на празни обороти: Kiirus tühikäigul Tuščio prietaiso greitis Tukšgaitas ātrums</p>	900 - 3200 min⁻¹
	<p>Classe d'isolement : 2 Insulation class : 2 Isolierung klasse : 2 Aislamiento clase :2 Isolamento classe :2 Isolamento classe :2 Isolatie Klasse : 2 Εργαλειο τάξη : 2 Izolacija Klazy :2 Eristysluokka :2 Isolering Klass :2 Isoleringsklasse 2 Clasă izolație :2</p>	<p>Класс изоляции 2 : Yalıtım derecesi :2 Třída izolace :2 Izolačný systém 2 סוג בידוד 2. فئة العزل 2. Szigetelési osztály :2 Razred izolacije :2 Инструмент Клас :2 Isolatsiooniklass 2 Izoliācijas rūšis 2 Izolācijas klase 2</p>	X

	<p>Poids : Weight : Gewicht : Peso : Peso : Gewicht : Βάρος : Masa : Paino : Vikt : Vægt : Greutate :</p>	<p>Вес : Ağırlık : Hmotnost : Hmotnosť : משקל الوزن. Súly : Teža : Терло : Raskus Svoris Svars</p>	5,2 kg
	<p>Lire les instructions avant usage : Read the instructions before use : Vor Einsatz des Geräts Anweisung lesen : Léase las instrucciones antes de usar : Leggere le istruzioni prima dell'uso : Ler as instruções antes da utilização : Lees voor het gebruik de instructies : Διαβάστε τις οδηγίες χρήσης : Zapoznać się z instrukcją przed użyciem : Lue ohjeet ennen käyttöä : Läs anvisningarna före användning : Læs instruktionerne før brug Înainte de utilizare, citiți instrucțiunile :</p>	<p>Внимательно прочитайте следующие инструкции : Kullanmadan talimatları okuyunuz : Pozorně si přečtěte následující pokyny : Pred použitím si prečítajte pokyny : רם חילופי اقرأ التعلیمات قبل الاستخدام. használat előtt olvassuk el az utasítást : Pred uporabo preberite ustrezna navodila : Прочетете указанията за употреба : Enne kasutamist lugege instruksiooni Prieš naudojimą perskaityti instrukciją izlasīt instrukcijas pirms lietošanas</p>	X
	<p>Conformité européenne Conforms to EC standards : CE-Konformität : Cumple con las directivas CE : Conforme alle norme CE : Conforme às normas CE : Voldoet aan de EG-normen : Σύμφωνα με τα πρότυπα Zgodność z normami CE : EU-standardien mukainen : EU-standardien mukainen : Overholder EU standarderne : Conform cu normele europene:</p>	<p>соответствие европейским стандартам: Avrupa uygunluk : evropská shoda : európska dohoda : התאמה לתקנים האירופיים مطابق للمواصفات الأوروبية. evropska ustreznost : európai megfeleléség : Съответствие с европейските норми : Euroopa Liidu vastavusmärk Euroopiņu normu atitikima Atbilstība Eiropas standartiem</p>	X
	<p>Danger : Danger : Gefahr : Periglio : Pericolo : Perigo : Gevaar : Κιίνδος : Niebezpieczeństwo : Vaara : Fara : Fare : Pericol :</p>	<p>Опасно : Tehlike : Nebezpečí : Nebezpečnostvo : סכנה. خطر. Veszély : Nevarnost : Опасно : Oht Pavojus Bīstamība</p>	X

	Diamètre de brosse et largeur : Diameter of wheel and width : Bürsten Sie Durchmesser und Breite: Cepillar diámetro y anchura: Escovar diâmetro e largura: Spennellare diametro e larghezza: Borstel diameter en breedte: Диáμετρο δίσκου : Srednica tarczy i otwór : Leikkuuterän läpimitta ja kalviminen : Skivans diameter och innerdiameter : Skivens ydre og indre diameter : Diametru disc și alezaj :	Диаметр диска и пропила : Disk ve delik çapı : Průměr kotouče a vrtání : Priemer kotúča a vnútorný priemer : קוטר הדיסקה וקידח قطر الأسطوانة والتمجويف A tárcsa és a furat mérete : Premer diska in izvrtine : Диаметър на резеца : Ketta ja puurimise diameeter : Skersmuo : Diska un caurplūdes atvērums diametrs :	ø 120 mm x 100 mm
---	--	---	--------------------------



- Cet appareil n'est pas prévu pour être utilisé par des personnes (y compris les enfants) dont les capacités physiques, sensorielles ou mentales sont réduites, ou des personnes dénuées d'expérience ou de connaissance, sauf si elles ont pu bénéficier, par l'intermédiaire d'une personne responsable de leur sécurité, d'une surveillance ou d'instructions préalables concernant l'utilisation de l'appareil.

- Il convient de surveiller les enfants pour s'assurer qu'ils ne jouent pas avec l'appareil.

- Dit product is niet bedoeld voor gebruik door personen (inclusief kinderen) met een lichamelijke, zintuiglijke of geestelijke vermogens, of gebrek aan ervaring of kennis, tenzij ze zijn gegeven door door een persoon die verantwoordelijk is voor hun veiligheid, toezicht of instructies over het gebruik van het apparaat.

- Het moet toezicht houden op kinderen om ervoor te zorgen dat zij niet met het apparaat spelen.

- This product is not intended for use by persons (including children) with physical, sensory or mental capabilities, or lack of experience or knowledge, unless they have been given by through a person responsible for their safety, supervision or instruction concerning use of the device.

- It should supervise children to ensure they do not play with the device.

- Este producto no está diseñado para ser utilizado por personas (incluidos niños) con capacidades físicas, sensoriales o mentales, o la falta de experiencia o conocimiento, a menos que hayan sido dadas por través de una persona responsable de su seguridad, supervisión o instrucciones relativas al uso del dispositivo.

- Se debe supervisar a los niños para asegurarse de que no jueguen con el dispositivo.

- Este produto não é destinado ao uso por pessoas (incluindo crianças) com capacidades físicas, sensoriais ou mentais, ou falta de experiência ou conhecimento, a menos que tenham sido dadas por através de uma pessoa responsável pela sua segurança, supervisão ou instruções relativas à utilização do dispositivo.

- Deve vigiar as crianças para garantir que eles não brincam com o dispositivo.

	<p>Soumis à recyclage Subjected to recycling Sujeto a reciclaje Sottoposti a riciclaggio Sujeitos à reciclagem Não deite no lixo : Niet wegwerpen : Μην την πετάτε : Nie wyrzucas : Älä heitä pois luontoon : Batteriet får inte kastas : Bortkast det ikke: Nu le auncati :</p>	<p>Не выбрасывайте в мусорный ящик Atmayiniz : Nevyhazujte je do bežného odpadu : Neodhadzovat : אין לזרוק סוללות فلا ترمدها لهذا في القمامة. ne mečíte! Ne odvržite ga/jih vstran : Не го изхвърляйте : Ärge visake seda minema : Nemétykíte : Nemest : Podvrgnuto recikliranju</p>	X
---	--	--	---

Recyclage des déchets :

Les outils, accessoires et leur emballages doivent suivre une voie de recyclage adaptée. Conformément aux directives Européenne 2012/19/UE et 2006/66/CE, les composants d'un produit doivent être séparés, collectés, recyclés ou éliminés en conformité avec les réglementations environnementales en vigueur. Les appareils, batteries, piles, huiles, emballages devront être déposés dans les systèmes d'élimination des déchets spéciaux tels que déchetteries. Renseignez-vous auprès de votre commune pour connaître l'organisme le plus proche à même de retraiter ou de collecter ces déchets.

	<p>Recyclable, soumis au tri sélectif Recyclable, subject to recycling Recyclingfähige, unterliegen Recycling Reciclables, sujetos a reciclaje Riciclabili, soggetti a riciclaggio Recicláveis, sujeito à reciclagem Recycleerbare, onderworpen aan recycling Ανακυκλώσιμες συσκευασίες που υπόκεινται σε κύκλωση Opakowanie nadaje się do recyklingu podlegają recyklingu Kierrätettävien pakkausten kohteena kierrätys Återvinningsbara förpackningar omfattas återvinning Рециклиращи се опаковки подлежат на рециклиране Genanvendelig underlagt genbrug</p>	<p>Reciclabile sub rezerva reciclaré Повторно упаковка подлежит вторичной переработке Geri dönüşüm Geri dönüşdürülebilir ambalaj konusu Recyklovateľné podléhající recyklaci Recyklovateľné podliehajúce recyklácii הוחמל הוחמל הזיראה אשונ ریودنلا ها ایل ریوسنمت ریودنلا ها ایل تلبانزلا فحیل رتلاو قویب رتلا Újrahasznosítható csomagolás alá újrahasznosítás Reciklirati predmet recikliranja Pakendite suhtes ringlussevõtu Pärsträdājams iepakojuoms otrreizējai pārstrādei Perdirbamų taikomos perdirbimo Može se reciklirati, podložno selektivnom sortiranju</p>	X
---	---	---	---

	Porter des lunettes de sécurité : Wear protective eyewear : Schutzbrille tragen : Llevar puestas gafas protectoras : Portare de gli occhiali di sicurezza : Utilizar óculos de segurança : Draag een veiligheidsbril : Φορέστε Προστατευτικά γυαλιά : Zakładać okulary ochronne : Käytä suojalaseja : Använd skyddsglasögon : Der skal benyttes sikkerhedsbriller : Purtati ocelari de protectie :	Наденьте защитные очки : Güvenlik gözlükleri takın : Požívejte bezpečnostní brýle : Noste ochranné okuliare : תחייב יפקשמ ביכרהל אן חמל נזפארט ופאיי. Viseljen védőszemiveget : Nositi zaščitna očala : Да се използват защитни очила : Kandke kaitseprille Nešioti apsauginius akinius Valkāt aizsargbrilles Nositi zaštitne naočale:	X
---	--	--	---

	Porter un masque anti-poussière : Wear a dust mask : Staubschutzmaske tragen : Llevar puesta una careta de protección contra el polvo : Indossare una mascherina anti-polvere : Utilizar uma máscara anti-poeira : Draag een stofmasker : χρήση προστατευτική μάσκα : Zakładać maskę przeciwpyłową Käytä pölysuojust : Bär mask mot damm : Der skal benyttes beskyttelsesmaske mod støv: Purtati mască anti-praf :	Наденьте респиратор : Toza karşı maske takın : Používejte masku proti prachu : Noste ochrannú masku proti prachu : קבא דגנ הכסמ שובחל אן ליבס קנאע מוצאח ללעבאר. Viseljen porvédő maszkot Nositi zaščitno masko proti prahu: Да се използва защитна маска : Kandke tolmumaski. Dëvëti respiratoriq. Valkāt aizsarg masku pret putekļiem Nositi masku za zaštitu od prašine:	X
---	--	---	---

	Porter une protection auditive : Wear hearing protective equipment: Gehörschutz tragen: Llevar puesta una protección auditiva: Portare una protezione uditiva: Utilizar uma protecção auditiva: Draag gehoorbeschermers: Φορέστε Προστατευτικά ακουστικά Zakładać słuchawki ochronne Käytä kuulosuojaimia: Bär hörselskydd: Der skal benyttes høreværn: Purtati căști de protecție auz:	наденьте средства звуковой защиты: İşitsel koruma aleti takın: Používejte ochrannu sluchu: Noste ochranné slúchadlá: יש ל הרכיב הגנת שמיעה ליבס חוזה חרזש ללעבאר Viseljen fülvédőt Nositi zašito ušes: Да се използва слухови защитни средства: Kandke kõrvakaitset Nešioti apsaugā nuo triukšmo Valkāt dzirdes aizsarglīdzekli Nositi štítnike protiv buke:	X
--	---	--	---

	Porter des gants : Use rubber gloves : Schutzhandschuhe tragen : Llevar guantes de protección : Indossare i guanti di protezione : Utilizar luvas de protecção : Draag veiligheidshandschoenen : χρήση προστατευτικών γαντιών : Używać rękawic ochronnych : Käytä suojakäsineitä : Använd skyddshandskar : Der skal benyttes handsker : Purtati mănuși :	Наденьте перчатки : Eldiven takın : Noste rukavice : Noste rukavice : תופכ שובלל אן ליבס קפארזאט. Viseljen kesztyű t Nositi rokavice: а се използват предпазни ръкавици : Kandke kindaid Müvēti pirštines Valkāt cimdus Nositi zaštitne rukavice:	X
---	--	---	---

 L_{pA}	Niveau de pression acoustique : Acoustic pressure level : Schalldruckpegel : Nivel de presión acústica : Livello di pressione acustica : Nivel de pressão acústica : Niveau akoestische druk : Στάθμη Θορύβου : Poziom mocy akustycznej : Käytä kuulosuojaimia : Ljudtrycksnivå : Lydtryk : Nivel presiune acustică :	Уровень акустического давления. : Akustik basınç seviyesi : Hladina akustického tlaku : Hladina akustického tlaku : רמת לחץ אקוסטי. مستوى الضغط السمعي. A hangnyomás szintje : Nivo akustičnega pritiska: Равнище на акустично налягане : Helirõhu tase Akustinio spaudimo lygis Akustiskā spiediena līmenis	102 dB (A)
--	---	---	-------------------

 L_{WA}	Niveau de puissance acoustique : Acoustic power level : Schalleistungspegel : Nivel de potencia acústica : Livello di potenza acustica : Nivel de potência acústica : Niveau akoestisch vermogen : Στάθμη Ονομαστική Θορύβου : Poziom mocy akustycznej : Käytä suojalaseja : Ljudstyrkenivå : Lydstyrke : Nivel putere acustică :	уровень мощности звука : Akustik basınç seviyesi : Hladina zvukového výkonu : Hladina zvukového výkonu: רמת כוח אקוסטי. مستوى الصوتي. a hangnyomás szintje : Nivo akustične jakosti : Равнище на вибрации : Helirõhususe tase Triukšmo lygis Akustiskās jaudas līmenis	114 dB (A)
--	---	--	-------------------

NEVEAU SONORE D'EMISSION:

A VIDE

Pression acoustique LpA poste opérateur
Incertitude

102 dB
3

Puissance acoustique LWA
Incertitude

114 dB
3

Valeurs déterminées suivant le code d'essai de l'annexe B de la norme EN 61029-1 avec emploi des normes de base ISO 11201 et ISO 3744.

Les niveaux de pression acoustique obtenus in situ dépendent:

- Des niveaux réels de la machine considérées, en prenant en compte les incertitudes déclarées;
- Du local et de l'installation de la machine. Préférez une pièce dont l'acoustique est plus feutrée. Evitez les pièces vide à grande résonance. Placez vous auprès d'une fenêtre le cas échéant.
- Des outils montés, des pièces travaillées, des réglages choisis,...

 L_{WA}	Niveau de vibration : Hand/arm vibration level : Vibrationspegel Hand/Arm : Nivel de vibración mano/brazo : Livello di vibrazione mano/braccio : Nivel de vibração mão/braço : Trillingsniveau hand/arm : Στάθμη κρα'οσσωμών : Poziom wibracji rżka/ramiż : Tärinätaso: Vibrationsnivå hand/arm : Vibrationsniveau : Nivel vibrații :	Уровень вибрации : Titreşim seviyesi : Úroveň vibrací : Hladina vibrácií : רמת תנודות مستوى الارتجاج. Vibrációszint : Nivo vibracij : Равнище : Vibrācijas līmenis. Vibrācijas lygis Vibratsiooni nivo	3,2 m / s²
--	--	--	------------------------------

VIBRATIONS:

Total des valeurs de vibration (somme vectorielle des trois directions) déterminée selon EN 60745:

a

3,2 m/s²

Incertitude K

1,5 m/s²

L'amplitude d'oscillation peut être utilisée comme valeur de comparaison d'outils électroportatifs.

Attention: Si l'outil électroportatif est utilisé pour d'autres applications, avec d'autres outils de travail, l'amplitude d'oscillation peut être différente.

REX 200

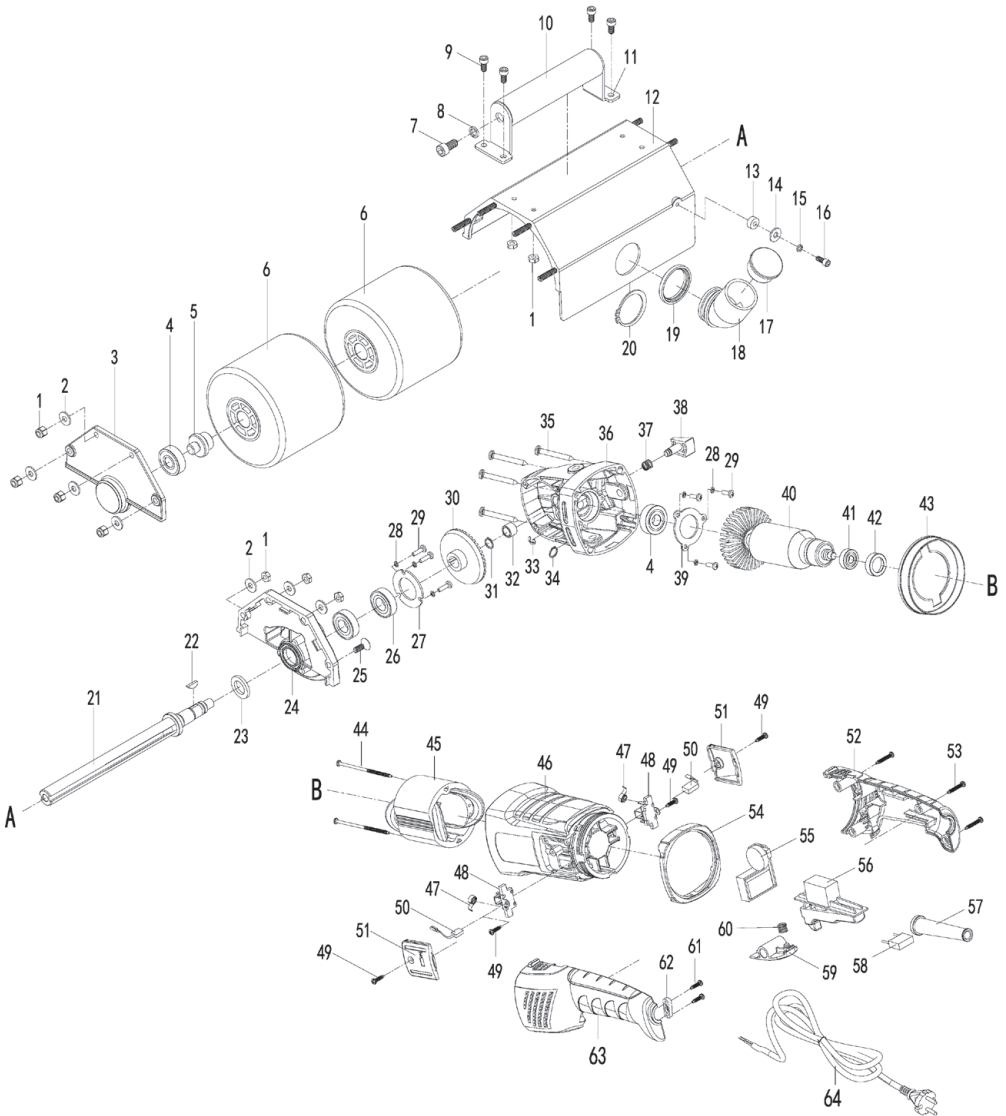



115015-Sticker-A-01-Normes.indd 1

27/02/2020 11:38



115015-Sticker-A-01-Normes.indd 2

27/02/2020 11:38



115015-Sticker-A-02-200mm.indd 1

27/02/2020 11:40

DECLARATION DE CONFORMITE
VERKLARING VAN OVEREENSTEMMING
DECLARACION DE CONFORMIDAD
DICHIARAZIONE DI CONFORMITA
KONFORMITÄSERKLÄRUNG
DECLARATION CONFORMITY
DECLARAÇÃO DE CONFORMIDADE
DEKLARACJA ZGODNOSCI Z NORMAMI
OM ÖVERENSSTÄMMELSE
VAATIMUSTENMUKAISUUSVAKUUTUS
ÖVERENSSTÄMMELSEERKLÄRUNG
ΔΗΛΩΣΗ ΣΥΜΜΟΡΦΩΣΗΣ
DECLARAȚIE DE CONFORMITATE

UYHLÁSENIE ZHODY
Декларация соответствия
הצהרת תאמת
Uygunluk beyanı
التصريح بالخطابفة
PROHLÁSENÍ SHODY
EGYEZŐSÉGI NYILATKOZAT
Декларация за съответствие с нормите
IZJAVA O SKLADNOSTI
DEKLARACIJA
ATITIKTIES DEKLARACIJA
KINNITUS
IZJAVA O SUKLADNOSTI

Le soussigné,
Ondergetekende,
Der Unterzeichner,
O abaixo assinado,
Undertecknad,
Долуподписаният
Undertegnede
Subsemnatul,
Ο κάτωθι υπογεγραμμένος,
Imzalayan,
Níže podepsany,
Toliau pasirašęs
El suscrito,

Déclare par la présente que,
Verklaart hiermede dat,
Erklärt hiermit daß,
Declara pela presente que,
Förklarar härmed att
Заявява с настоящото
erklærer hermed, at
Declar prin prezenta că,
Με το παρόν δηλώνει ότι,
Mevcut belgeyle beyan ediliyor ki,
tímto prohlašuje, že,
Pareiškia, kad,
Declara por la presente, que,

Personne autorisée à constituer
le dossier technique :
Ronan GULLIOT



FAR GROUP EUROPE
192, Avenue Yves Farge
37700 St. Pierre-des-Corps
FRANCE

Il sottoscritto,
The undersigned,
Ninej podpisany
Allékirjoittanut,
Oyttogegramm9enoz
Nižšie podpisany
החתום מטה
الجوقع أدناه
Alulírott,
Podpisani,
Apakšā parakstijies
allakirjutanu
Dolje potpisani,

Dichiare che,
Declares that,
OÖwiadcza niniejszym, że
Ilmoitetaan täten että,
Dhl9vnei me thn Paro9yasa
týmto vyhlasuje, že
מצהיר בזה כי
يصرح استنادا على ذلك
kijelentem, hogy a készülék Izjavlja da,
Pareiškia, kad,
Ar šo apliecina, ka,
Kinnitab, et
Izjavljuje u ovom dokumentu da je

Rénovateur extérieur / Exterior renovator / Schleif- und Renoviergerät / Fuera renovador / Restauratore di fuori / Fora renovador / Buiten renovator /
Έξω από ανακαινιστής / **Poza nowatora / Ulkopuoilella remontoijille / Utanför renovator / Извън обновител / Udenfor renovator / In afara renovator /**
Bue pecmasapoma / Yenileyen aşında / Mimo renovátor / Mimo renovátor / كينوايش مرمم / كرمم مرمم / Kivül renovator / Zunan Obnovilac / Önes renovator /
ārpus atjaunotājs / Už Restorer / Vanjski renovator

code

FARTOOLS / 115015 / REX 200 / S1P-HJ2213H

Est conforme et satisfait aux directives et normes CE,
In overeenstemming is met en Voldoet aan EG richtlijnen,
Den folgenden EU-Bestimmungen entspricht,
Respeita e está em conformidade com as normas CE,
Överensstämmer med och uppfyller EG-standarder,
Съответства и отговаря европейските норми
Er i överensstämelse med og overholder EU standarderne
Este conform și satisface normele CE
полностью соответствует и удовлетворяет требованиям стандартов EC
CE şartlara uygundur,
odpovídá normám ES.
Atitinka ir atitinka EB direktyvas ir standartus,
Cumple con la directivas de la CE,

È conforme alle direttive CEE,
Complies with the EEC directives and standards,
Odpowiada normom UE,
Täyttää EU-vaatimukset,
Συμμορφώνεται και πληροί τις οδηγίες και τα πρότυπα CE,
zodpovedá normám ES.
מתאים ועונה לתקני CE
بأن الجهاز يطابق ويالبي مجموعة الدول الأوروبية
kielegíti a CE szabványok előírásait.
Je v skladu z in izpolnjuje norme Evropske skupnosti.
Atbilst un atbilst EK direktīvas un standartus,
Vastab ja vastab EÜ direktīviudele ja standartitele,
Sukladan i ispunjava direktive i standarde CE,

2006/42/EC 2014/30/EU 2011/65/EU 2015/863/EU

EN62841-2-4:2014
EN62841-1:2015+AC:2015

EN IEC 55014-1:2021
EN IEC 55014-2:2021
EN IEC 61000-3-2:2019+A1:2021
EN61000-3-3:2013+A1:2019

Ronan GULLIOT,
Directeur général
25/10/2022
Fait à St. Pierre-des-Corps



FR. GARANTIE

Cet outil est garanti contractuellement contre tout vice de construction et de matière, à compter de la date de vente à l'utilisateur et sur simple présentation du ticket de caisse. La garantie consiste à remplacer les parties défectueuses. Cette garantie n'est pas applicable en cas d'exploitation non conforme aux normes de l'appareil, ni en cas de dommages causés par des interventions non autorisées ou par négligence de la part de l'acheteur. La garantie ne s'applique pas sur les dommages causés par une défaillance de l'outil.

DE. GARANTIE

Die Garantiezeit für dieses Gerät in Bezug auf Konstruktions- und Materialfehler beträgt lt. Vertrag bei Vorlage des Kassabons. Die Garantieleistung besteht im Ersatz schadhafter Teile. Die Garantie erlischt bei einem Einsatz des Geräts, der nicht normentsprechend ist, bei Schäden, die auf unsachgemäße Eingriffe zurückzuführen sind bzw. bei Nachlässigkeit seitens des Käufers. Die Garantie erstreckt sich nicht auf Schäden, die auf Fehlfunktionen des Geräts zurückzuführen sind.

IT. GARANZIA

Quest' attrezzo è garantito per contratto contro qualsiasi difetto di costruzione e di materia, a partire dalla data di vendita all' utente e su semplice presentazione dello scontrino. La garanzia consiste nel sostituire le parti difettose. Questa garanzia non è applicabile in caso di sfruttamento non conforme alle norme dell' apparecchio, né in caso di danni causati da interventi non autorizzati o da negligenza da parte dell' acquirente. La garanzia non si applica ai danni causati da un avaria dell' attrezzo.

EN. GARANTEE

This tool is guaranteed, in writing, against any defect in manufacture of parts from the date of sale, upon simple presentation of the sales slip. The guarantee is limited to the replacement of faulty parts. This guarantee is not applicable in the event of usage which is not conform with the intended usage of the apparatus, nor in the event of damage caused by unauthorised servicing or negligence on behalf of the purchaser. This guarantee does not apply to any damage caused by the failure of this tool.

ES. GARANTIA

Esta herramienta se garantiza contractualmente contra todo defecto de construcción y materia, a partir de la fecha de venta a l' usuario y sobre simple presentación del recibo de caja. La garantía consiste en sustituir a las partes defectuosas. Esta garantía no es aplicable en caso de explotación no conforme a las normas del aparato, ni en caso de daños causados por intervenciones no autorizadas o por negligencia por parte del comprador. La garantía no se aplica sobre los daños causados por un fallo del herramienta.

NL. GARANTIE

Dit gereedschap heeft een garantie tegen constructiefouten en materiaaldetecten, die geldig is vanaf de aankoopdatum door de gebruiker, op vertoning van de kassabon. De garantie betreft de vervanging van de defecte onderdelen. Deze garantie is niet van toepassing indien het apparaat niet volgens de normen gebruikt is, noch in geval van schade veroorzaakt door onregelmatig gebruik of nalatigheid van de koper. De garantie is niet van toepassing op schade voortvloeiend uit een defect van het gereedschap.

PT. GARANTIA

Esta ferramenta tem uma garantia contratual contra qualquer defeito de construção e de material, a partir da data de venda ao utilizador e sobre simples apresentação do talão da caixa. A garantia consiste em substituir as partes defeituosas. Esta garantia não é aplicável no caso de exploração não conforme as normas do aparelho, nem em caso de danos causados pelas intervenções não autorizadas ou por negligência da parte do comprador. A garantia não se aplica para os danos causados por uma falha da ferramenta.

EL. ΓΑΡΑΝΤΙΑ

ΑΥΤΟ ΤΟ ΕΡΓΑΛΕΙΟ ΕΙΝΑΙ ΣΥΜΒΑΤΙΚΑ ΕΓΓΥΗΜΕΝΟ ΓΙΑ ΟΠΟΙΟΔΗΠΟΤΕ ΚΑΤΑΣΚΕΥΑΣΤΙΚΟ ΚΑΙ ΥΛΙΚΟ ΕΛΑΤΤΩΜΑ, ΑΠΟ ΤΗΝ ΗΜΕΡΟΜΗΝΙΑ ΠΩΛΗΣΗΣ ΣΤΟΝ ΧΡΗΣΤΗ ΚΑΙ ΜΕ ΤΗΝ ΕΠΙΔΕΙΞΗ ΤΗΣ ΑΠΟΔΕΙΞΗΣ ΠΩΛΗΣΗΣ. Η ΕΓΓΥΗΣΗ ΣΥΝΙΣΤΑΤΑΙ ΣΤΗΝ ΑΝΤΙΚΑΤΑΣΤΑΣΗ ΤΩΝ ΕΛΑΤΤΩΜΑΤΙΚΩΝ ΕΞΑΡΤΗΜΑΤΩΝ. ΑΥΤΗ Η ΕΓΓΥΗΣΗ ΔΕΝ ΙΣΧΥΕΙ ΣΕ ΠΕΡΙΠΤΩΣΗ ΛΕΙΤΟΥΡΓΙΑΣ ΠΟΥ ΔΕΝ ΣΥΜΜΟΡΦΩΝΕΤΑΙ ΜΕ ΤΑ ΠΡΟΤΥΠΑ ΤΗΣ ΣΥΣΚΕΥΗΣ, ΟΥΤΕ ΣΕ ΠΕΡΙΠΤΩΣΗ ΖΗΜΙΑΣ ΠΟΥ ΠΡΟΚΑΛΕΙΤΑΙ ΑΠΟ ΜΗ ΕΞΟΥΣΙΟΔΟΤΗΜΕΝΕΣ ΕΠΕΜΒΑΣΕΙΣ Ή ΑΜΕΛΕΙΑ ΕΚ ΜΕΡΟΥΣ ΤΟΥ ΑΓΟΡΑΣΤΗ. Η ΕΓΓΥΗΣΗ ΔΕΝ ΙΣΧΥΕΙ ΓΙΑ ΖΗΜΙΕΣ ΠΟΥ ΠΡΟΚΑΛΟΥΝΤΑΙ ΑΠΟ ΑΣΤΟΧΙΑ ΕΡΓΑΛΕΙΟΥ.

PL. GWARANCJA

Narz dzie jest objte gwarancja na wszelkie wady konstrukcyjne i materiałowe, licząc od daty

sprzedaży u użytkownikowi i po okazaniu, paragonu, kasowego. Gwarancja obejmuje wymianę cz.ści wybrakowanych. Gwarancja nie znajduje zastosowania w przypadku użycowania niezgodnego z normami urządzenia, ani w przypadku szkód spowodowanych działaniami niedozwolonymi lub zaniedbaniami ze strony nabywcy. Gwarancja nie obejmuje szkód powstałych z powodu upadku urządzenia.

SV. GARANTI

Detta verktyg har en avtalsenlig garanti mot konstruktions och materialfel, från och med tidpunkten för användarens inköp och genom uppvisning av kassakvittot. Garantin består i att ersätta de bristfälliga delarna. Denna garanti gäller inte om användningen inte motsvarar apparatens standarder, inte heller vid skador som orsakas av ej tillätna ingrepp eller på grund av Koparens vårdslöshet. Garantin gäller inte forskador som orsakats av att verktyget fungerat bristfälligt.

FI. TAKUU

Tämän laitteen takuu on voimassa sopimusmukaisesti katkaen kaikki rakenne- ja materiaali- tai lukien ostopäivästä. Kassakuittia vastaan. Takuu sisältää viallisten osien korvaamisen. Takuu ei korvaa ohjeiden vastaista käyttöä eikä välttämättömyyden henkilöiden käsittelystä tai ostajan huolimattomuudesta aiheutuneita vahinkoja. Takuu ei vastaa myöskään toimintahäiriöistä aiheutuneita vahinkoja.

BU. Гаранция

Този инструмент е под договорна гаранция срещу всякакъв дефект в изработката и използваните материали, считано от датата на продажба на потребителя и само срещу представяне на касовата бележка. Гаранционното обслужване се състои в замяна на дефектните части. Настоящата гаранция не е валидна когато aparatът се използва по начин, несъответстващ на стандарта за работа с него, както и в случай на щети, нанесени от неоторизирани лица, или вследствие на проявена небрежност от страна потребителя.

Гаранцията не покрива щети, произтекли вследствие на техническа неизправност на апарата.

DA. GARANTI

Dette værktøj er dækket af en garantikontrakt for konstruktions- og materialefejl, som gælder fra købsdatoen ved visning af kassebonen. Garantien består i at udskifte de defekte dele. Garantien dækker ikke fejl opstået som følge af anvendelse, som ikke overholder standarderne for apparatet, eller

SERVICE APRÈS VENTE - AFTER SALE SERVICE

FARGROUP EUROPE - 192, Avenue Yves Farge - 37700 St. Pierre-des-Corps - FRANCE
fargroup@fargroup.net



skader opstået ved ikke autoriserede indgreb eller sløsethed fra brugerens side. Garantien dækker ikke skader opstået, fordi værktøjet har svigtet.

RO. GARANTIE

Acest aparat este garantat din punct de vedere contractual împotriva tuturor viciilor de construcție și de material, începând de la data vanzării lui către utilizator și la simpla prezentare a bunului de casă. Garanția constă în înlocuirea componentelor defecte. Această garanție nu se aplică în cazul exploatării în alt mod decât cel recomandat de normele aparatului și nici în caz de stricăciuni provocate de intervenții neautorizate sau prin neglijența cumpărătorului. Garanția nu se aplică asupra pagubelor cauzate de o defectare a aparatului.

RU. ГАРАНТИЯ

Данное изделие обладает измещенной силой гарантии, покрывающей все возможные дефекты изготовления и материала. Гарантия вступает в силу с даты продажи изделия пользователю, для этого достаточно сохранить и предъявить полученный в кассе чек. Гарантия обязывает изготовителя заменить дефектные части изделия. В случае не соответствующего нормам использования изделия, несанкционированного демонтажа или ремонта или небрежного обращения действие гарантии прекращается. Гарантия не покрывает ущерба, возникшего в результате сбоев в работе изделия.

TU. GARANTIJA

Bu araç, satış tarihinden itibaren, kullanıcının sadece vezne alındısını sunmasıyla tüm üretilen ve malzeme hatasına karşı garantilidir. Garanti eksik olan kısımları degistirmek icindir. Bu garanti aracin sartlarina uygun olmayan isleme durumunda, izin verilmeveyen kullanimlardan kaynaklanan, hasarlarda veya alicinin istegi durumunda uygulanmaz. Garanti malzemenin bir eksikliginden meydana gelen bir zararda uygulanmaz.

CS. ZÁRUKA

Pro tento nástroj platí smluvní záruka na všechny výrobní a materiálové vady od data prodeje uživateli a na základe predložení pokladního bloku. Záruka spocíva ve výmene vadných častí. Táto záruka neplatí v prípade použiti prístrojov, ktoré

neodpovídá normám, ani v případě škod způsobených nepovolenými zásahy nebo nedbalostí ze strany kupujícího. Záruka se nevztahuje na škody způsobené zavádou nástroje.

SK. ZÁRUKA

Pre tento nástroj platí zmluvná záruka na všetky výrobné a materiálové chyby od dátumu predaja užívateľovi a na základe predloženia pokladničného bloku. Záruka spocíva vo výmene chybných častí. Táto záruka neplatí v prípade použitia prístrojov, ktoré neodpovedajú normám, ani v prípade škod spôsobených nepovolenými zásahmi alebo nedbalosťou zo strany kupujúceho. Záruka sa nevztahuje na škody spôsobené poruchou nástroja

AR. الضمان

على محرم تقديم بطاقة لشراء يتغل في تاريخ البيع الى المشتري عمل وبراءا في التصدي عوفى الحواد، إعتباراً من الع رة مضمونه تغاردي من أي عيب في حالة تعرضه لآتلافات إن منه غير المطابق لمعاريي الجهان، ولا قبلًا للتطبيق في حالة الأستخدام العاطلة لآي لئون هذا الضمان الناتج عن عطل الضمان فاي ستيبذر المشتري لا ينطبق الضمان على البديل غير مخصصة أو في حالة الأمل من قبل ناتجة عن عطل يات تدخل

HU. GARANCIA

Erre a szerszámra szerződéses garanciát vállalunk bármilyen gyártási es anyaghiba felmerülése esetére a fogyasztó részere tartent eladás napjától számítva, a penztári blokk egyszerű felmütatása elleneben. A garancia a hibás alkatrészek cseréjére terjed ki. Ez a garancia nem érvényes, ha a készülék nem rendeltetésszerűen használtak, sem illetékeltlen beavatkozások, vagy a vásárló hanyagsága okozta károk esetén. A garancia nem fedezi azokat a károkat, melyeket a szerszám hibás működése okozott.

SL. GARANCIJA

To orodje je z garancijsko pogodbo zaščiteno proti vsem napakam v izdelavi in v sestavnem materialu od datuma prodaje naprej in ta velja ob predložitvi blagajniškega računa. Garancija velja za zamenjavo delov z napako. Ta garancija ne velja za uporabo orodja, ki ni v skladu z normami, predpisanimi za omejeno orodje in za primere okvar, ki nastanejo zaradi nedovoljenih posegov na orodju ali zaradi malomarnega rokovanja kupca. Garancija ne velja za škodo, ki jo lahko povzroci okvara orodja.

ET. GARANTII

See tööriist kuulub lepingu järgi garantiiremonti arvestades alates müümise päevast ja kasutajeksi alusel kasutajale koigi konstruktsiooni-

ja materjalivigade puhul. Garantii seisneb defektsete osade vahetamises. See garantii ei kehti paraaradi normide ebatavalise eiramise puhul ega ostja poolt keelatud viisil, kasutamises või hooletussejätmisest tulenevate kahjude korral. Garantii ei kehti seadme defektidest põhjustatud kahjude puhul

LV. GARANTIJA

Sis prietaisas yra uztkrinamas kaip itin geros kokybes, nup jo pardavimo datos iki jo panaudojimo, ir jam yra suteikiamas garantinis talonas. Garantijos metu galima pakeisti atsiradusius trumplajikius gedimus. Si garantija netaikoma esant netinkamam naudojimui ar nesilaikant reikiam sio aparato vartojimo instrukcijai, tai pat paciam pirkeiui ji sugadinus. Garantija taip pat netaikoma prietaisa naudojant ne pagal paskirti ir ji apgadinus

LT. GARANTIJA

Sim darbarikam ir liguma noteikta garantija visiem defektiem, kas saistās ar konstrukciju un materiālu, sakot ar pardosanas datumu, kad masinu parod lietotajam un vienkarši uzradot kases ceku. Garantija ieklaui bojato dalu nomainu. Si garantija nav deriga, ja aparats nav lietots saskaņā ar drošibas noteikumiem, ne gadijumos ja bojajumi radusies nesankcionetas lejauksanas gadijuma vai ari pirceja nolaidibas del. Garantija nav deriga, ja bojajumi radusies darbarika defekta del

HR. JAMSTVO

Ovaj alat ima ugovorno jamstvo u slucaju bilo kakvih nedostataka u konstrukciji i materijalu, od datuma prodaje korisniku uz jedinstavno predocenje racuna. Jamstvo se sastoji u zamjeni neispravnih dijelova. Ovo se jamstvo ne primjenjuje u slucaju uporabe i eksploatacije koja nije skladna standardima uređaja, niti u slucaju stete uzrokovane neovlaštenim intervencijama ili nemarkom kupca. Jamstvo se ne primjenjuje na stetu uzrokovanu nekim nedostatkom alata.

SERVICE APRÈS VENTE - AFTER SALE SERVICE

FARGROUP EUROPE - 192, Avenue Yves Farge - 37700 St. Pierre-des-Corps - FRANCE
fargroup@fargroup.net



FAR GROUP EUROPE

Une société du groupe **SIGMA**

192, Avenue Yves Farge
37700 St. Pierre-des-Corps
FRANCE

fartools.com

