

# FAR TOOLS®



## AE 850

Professional Machine

FR	Affleureuse électrique (Notice originale)
EN	Electric router (Original manual translation)
DE	Elektrische Oberfräse (Übersetzung aus dem Original-Anleitung)
ES	Anuradora eléctrica (Traducción del manual de instrucciones originale)
IT	Fresatrice elettrico (Traduzione dell'avvertenza originale)
PT	Tupia eléctrica (Tradução do livro de instruções original)
NL	Elektrische Bovenrees (Vertaling van de originele instructies)
EL	Ηλεκτρικός δρομολογητής (Αρχικές οδηγίες)
PL	Router elektryczny (Tłumaczenie z oryginalnej instrukcji)
FI	Sähköinen reititin (Käännös alkuperäisestä ohjeet)
SV	Elektrisk router (Översättning från originalinstruktioner)
BG	Електрически рутер (Превод на оригиналната инструкция)
DA	Elektrisk router (Oversættelse fra oprindelige brugsanvisning)
RO	Ruter electric (Traducere din instrucțiunile originale)
RU	Электрический маршрутизатор (Перевод с оригинальной инструкции)
TR	Elektrikli yönlendirici (Orijinal talimatlar çeviri)
CS	Elektrická horní frézka (Překlad z originálního návodu)
SK	Elektrická horná frézovačka na drevo (Preklad z originálneho návodu)
HE	לי (חותכן אריח חשמלי גוּם חשמלי (מדריך מקורי) גוּם חשמלי (מדריך מקורי))
AR	(في لصاأا اءاميل عءالا نم ءمء برءالا) يءأ برءك رءءوار
HU	Elektromos router (Fordítás az eredeti utasítások)
SL	Električni usmerjevalnik (Prevod iz izvirnih navodil)
ET	Elektriline ruuter (Tõlge originaal juhiseid)
LV	Elektriskais maršrutētājs (Tulkojumā no instrukcijas oriģinālvalodā)
LT	Elektrinis maršrutizatorius (Vertimas iš originalių instrukcijas)
HR	Električni usmjerivač (Prijevod prema originalne upute)



© FAR GROUP EUROPE

115400-A-20221128

# fartools.com



**5 min**





Description et repérage des organes de la machine  
Description and location of machine parts

# A



Contenu du carton  
Contents of box

# B

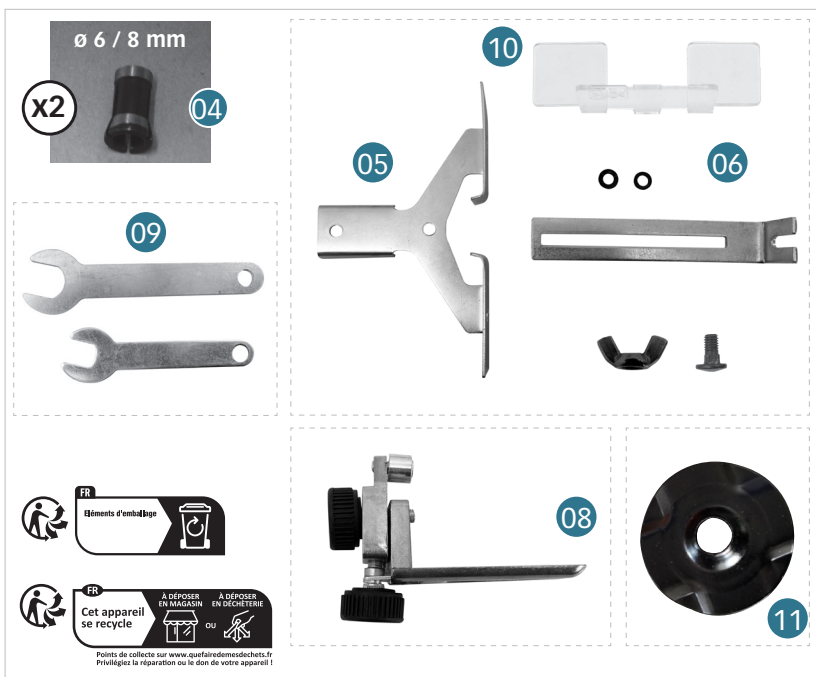

À DÉPOSER EN MAGASIN À DÉPOSER EN DÉCHÈTERIE  
OU  
Points de collecte sur [www.quefairede mesdechets.fr](http://www.quefairede mesdechets.fr)  
Privilégiez la réparation ou le don de votre appareil !



Assemblage de la machine  
 Assembly of the machine

C

01

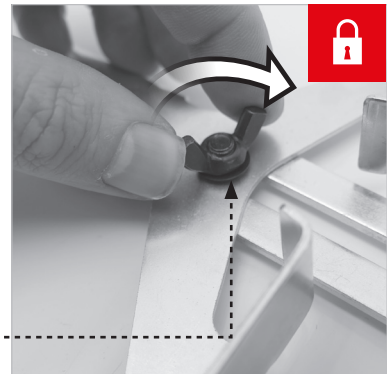
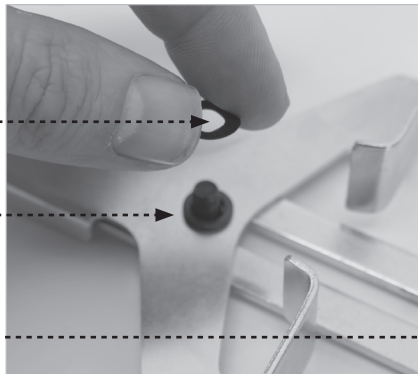
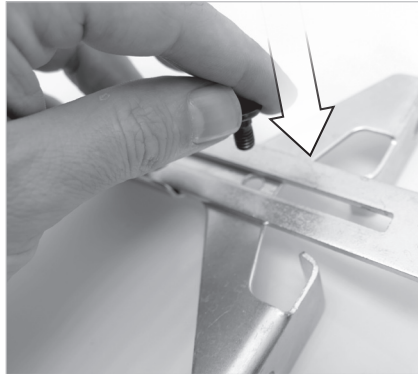
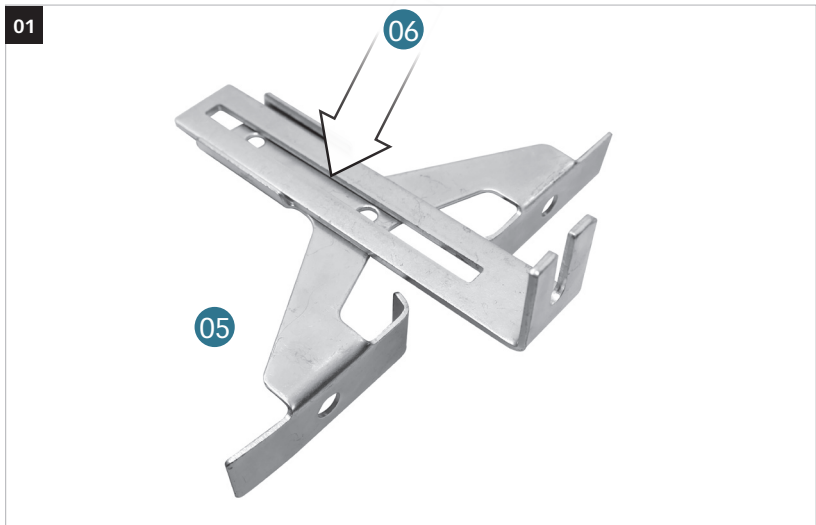



Assemblage de la machine  
Assembly of the machine

C

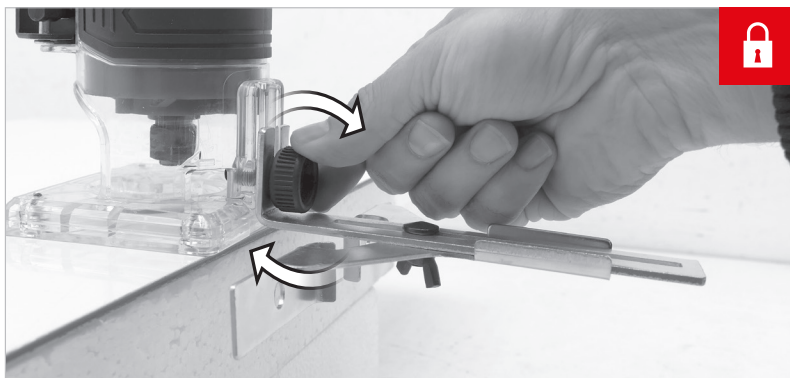



Assemblage de la machine  
Assembly of the machine

C

10

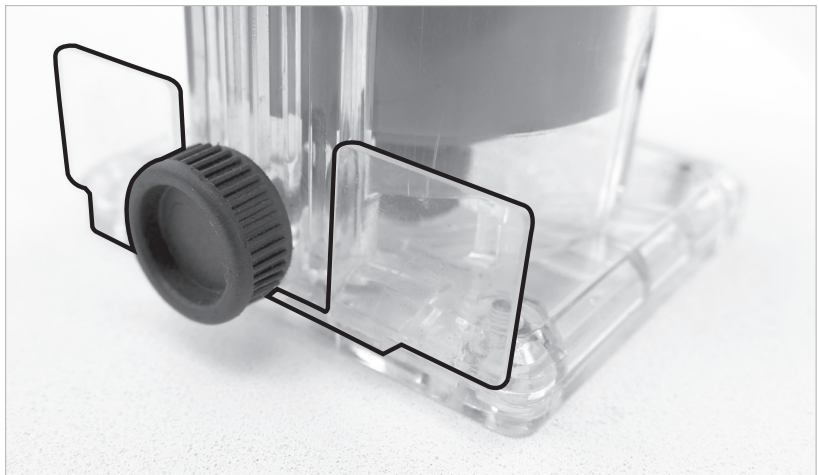
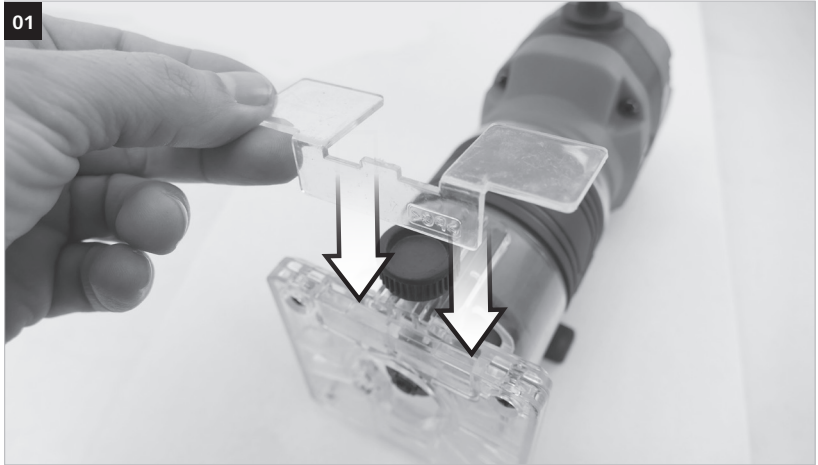



Réglages de la machine  
Machine settings

D

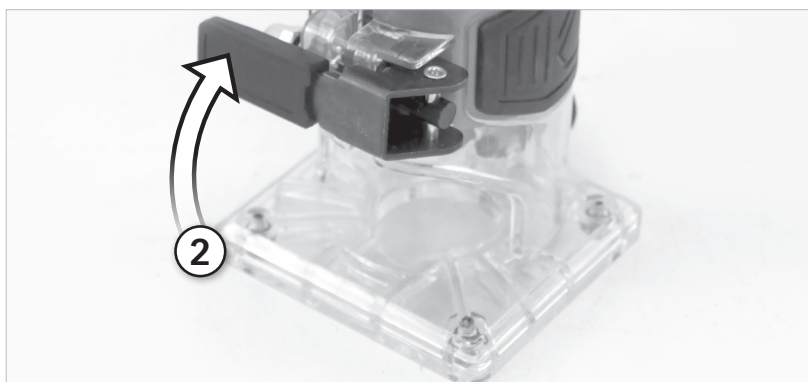



Réglages de la machine  
Machine settings

D

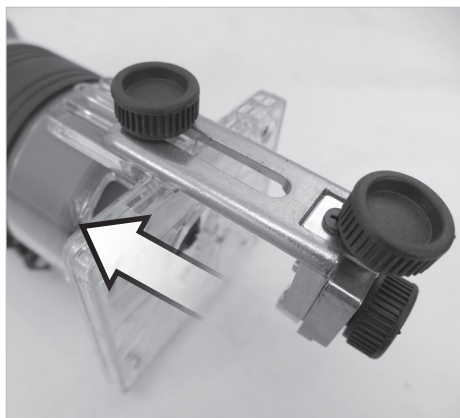
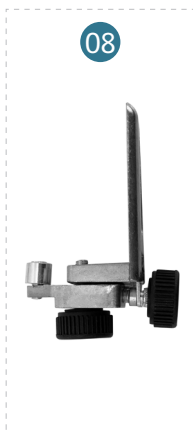
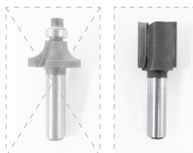

**Le guide de fraisage (08) sert à travailler des bords avec des fraises sans roulement à billes.**

De freesaanslag (08) wordt gebruikt om randen te bewerken met frezen zonder kogellagers.

La guía de fresado (08) se utiliza para trabajar los bordes con fresas sin cojinetes de bolas.

A guia fresa (08) é utilizada para trabalhar arestas com fresas sem rolamentos de esferas.

La guida di fresatura (08) serve per lavorare i bordi con frese senza cuscinetti a sfera.

The milling guide (08) is used to work edges with milling cutters without ball bearings.







Réglages de la machine  
Machine settings

D

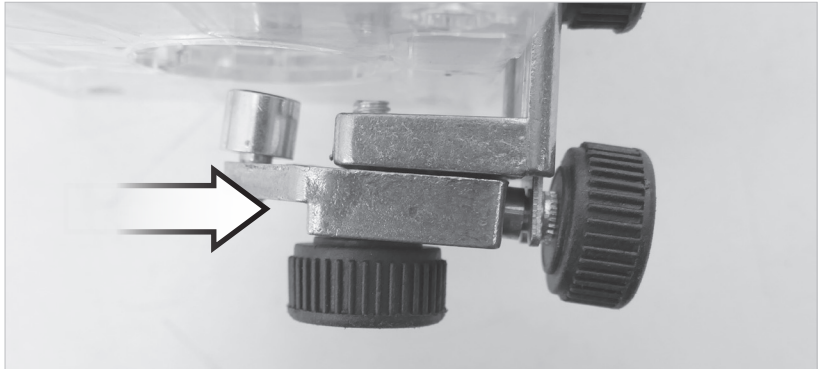
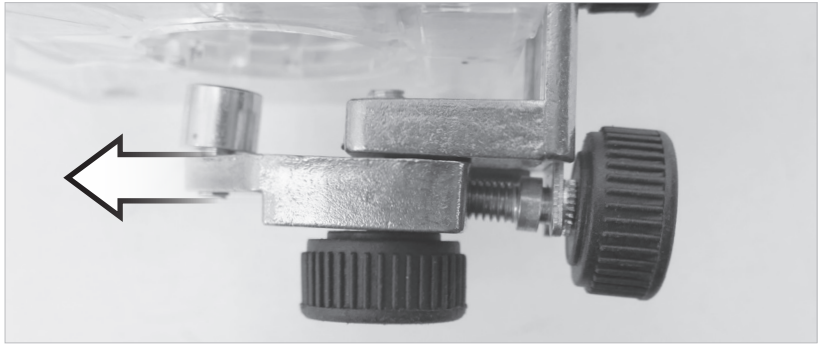
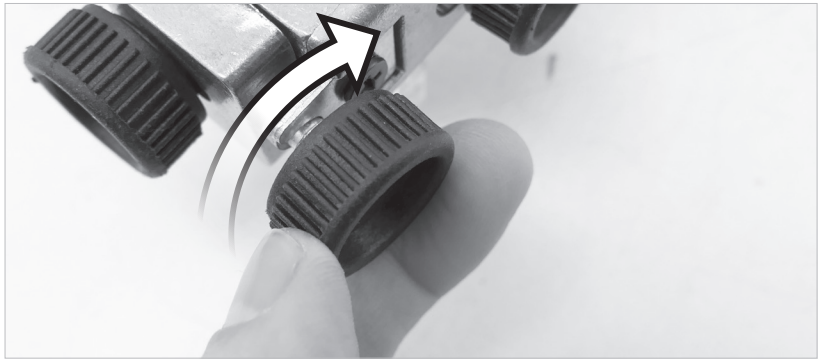



Réglages de la  
machine  
Machine settings

D

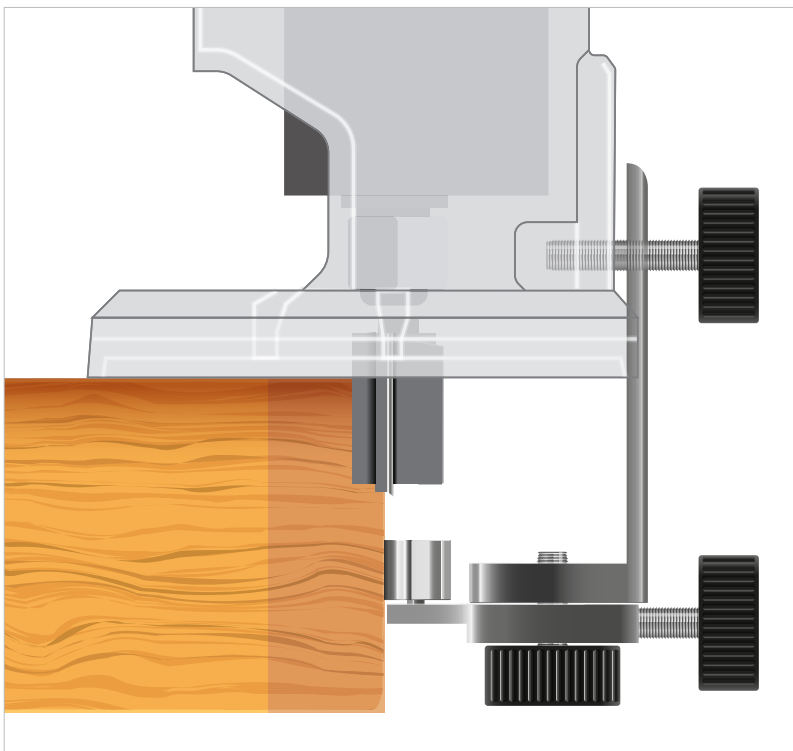
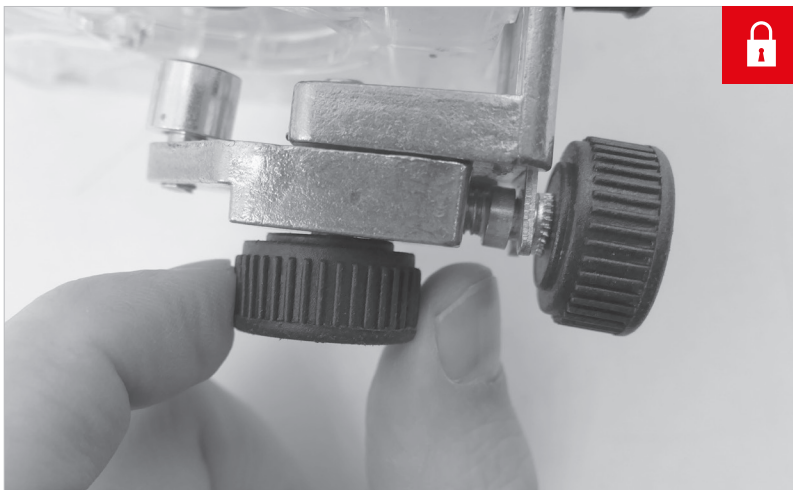

**Guidez l'affleureuse le long du bord de la pièce de bois en avançant régulièrement.**

Leid de trimmer langs de rand van het stuk hout en ga gestaag vooruit.

Guíe la recortadora a lo largo del borde de la pieza de madera, avanzando de manera constante.

Guíe o aparador ao longo da borda do pedaço de madeira, avançando de forma constante.

Guida il decespugliatore lungo il bordo del pezzo di legno, avanzando costantemente.

Guide the trimmer along the edge of the piece of wood, advancing steadily.





Fonctionnalité de la machine  
Functions of the machine

E

01

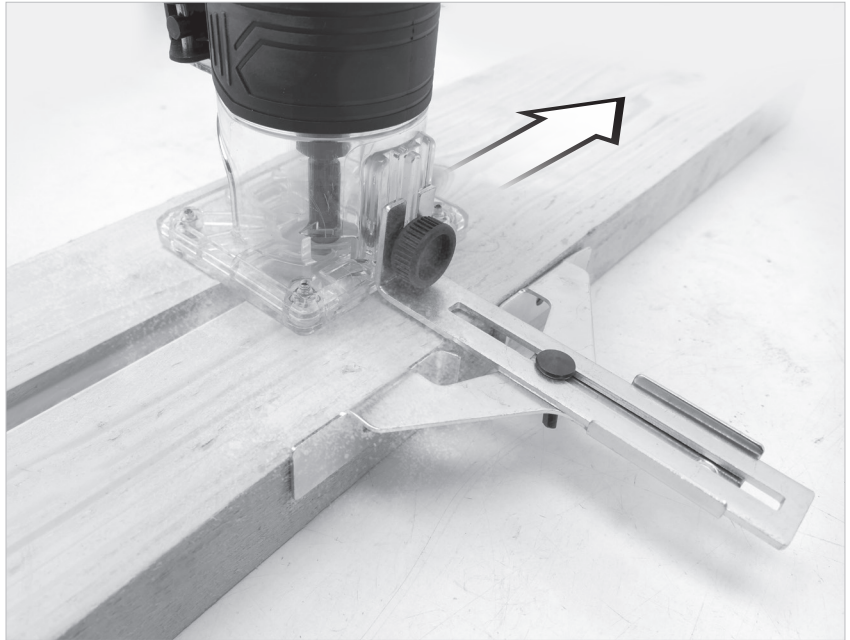
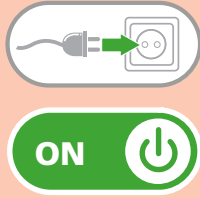



Fonctionnalité de la machine  
Functions of the machine

E



### Utilisation de la machine à main levée

De machine uit de vrije hand gebruiken

Usando la máquina a mano alzada

Usando a máquina à mão livre

Usando la macchina a mano libera

Using the machine freehand





Fonctionnalité de la machine  
Functions of the machine

E

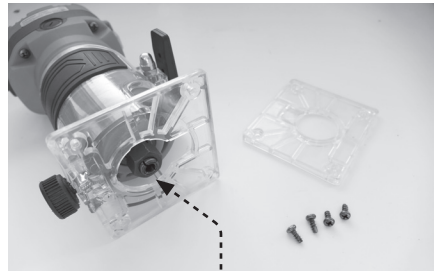
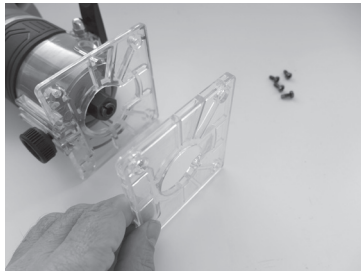
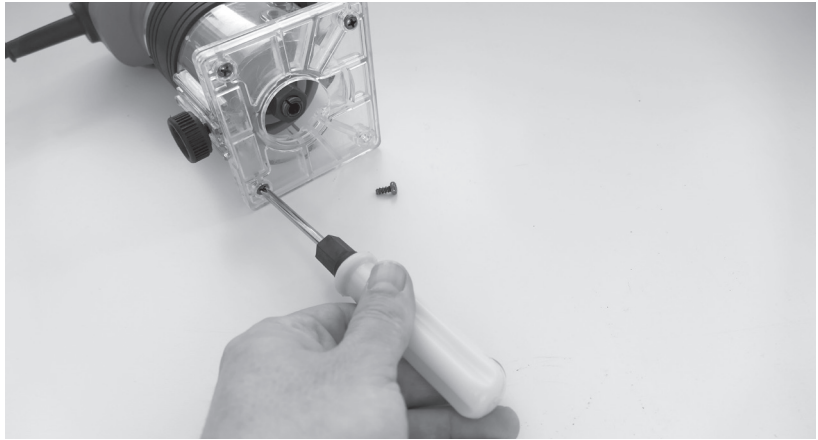
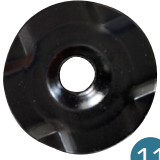

11

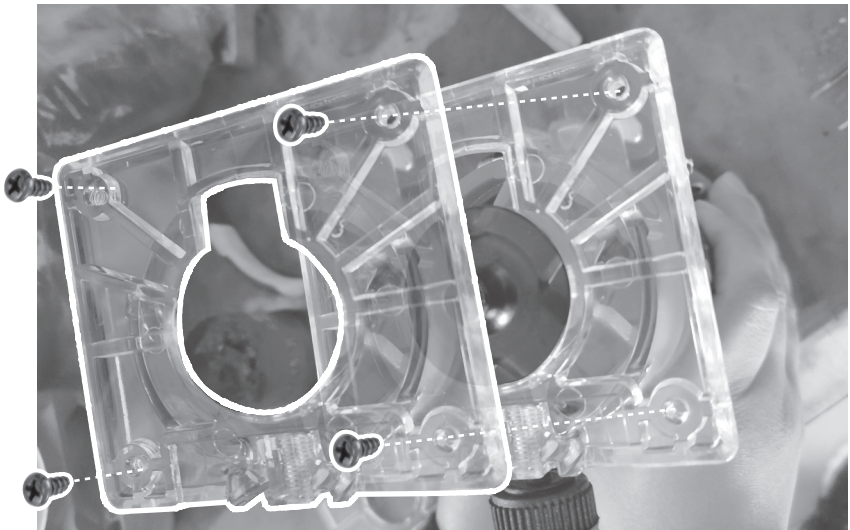
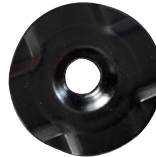



Fonctionnalité de la machine  
Functions of the machine

**E**

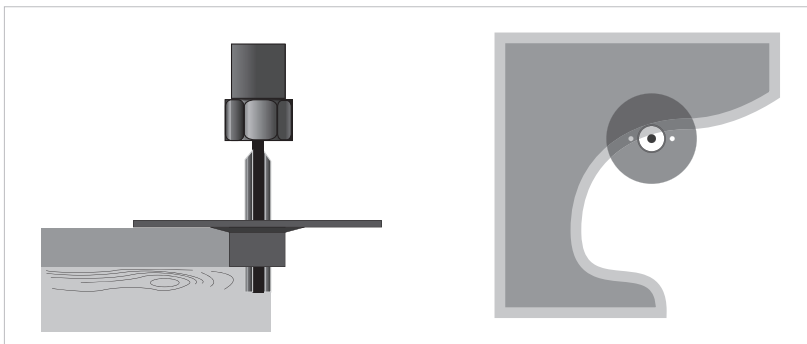

Gabarit  
Sjabloon  
Modelo  
Modelo  
Modello  
Template

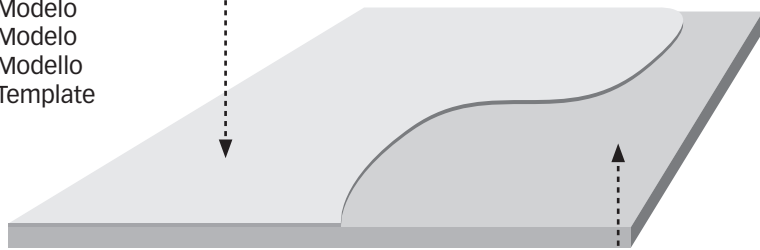

Pièce à travailler  
werkstuk  
pieza de trabajo  
peça de trabalho  
pezzo  
werkstuk

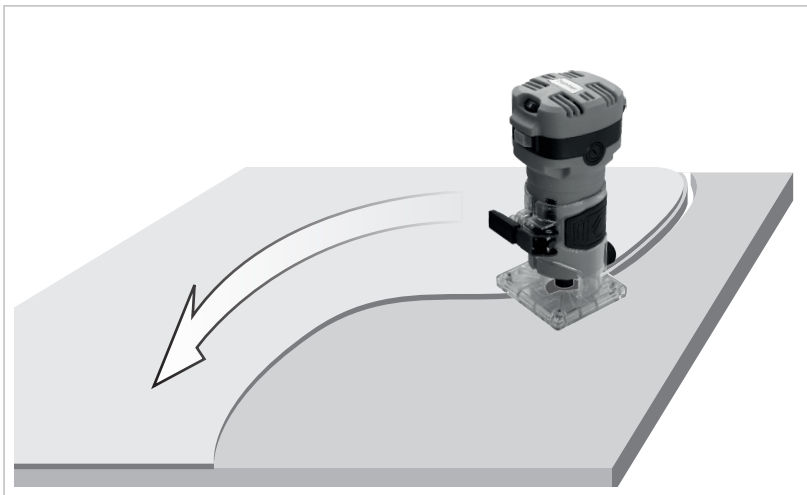

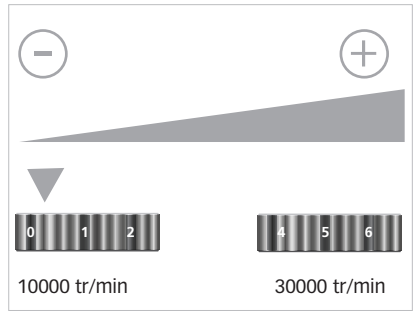

Remplacement des consommables  
Consumables replacing

F

01

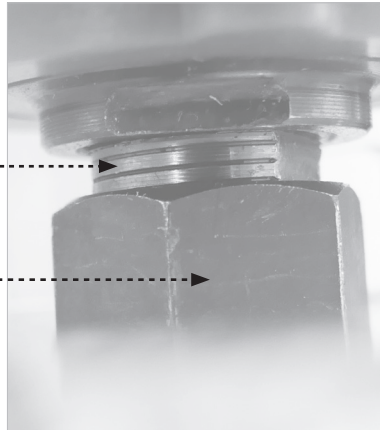
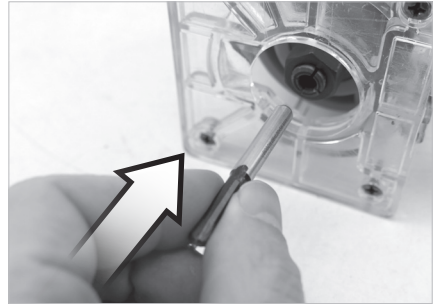
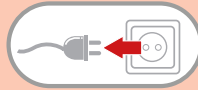



Remplacement des  
consommables  
Consumables  
replacing

**F**

09

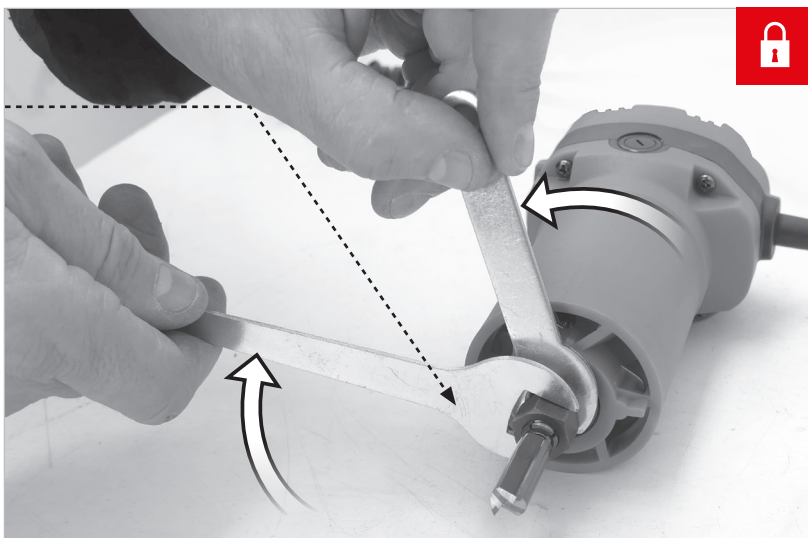
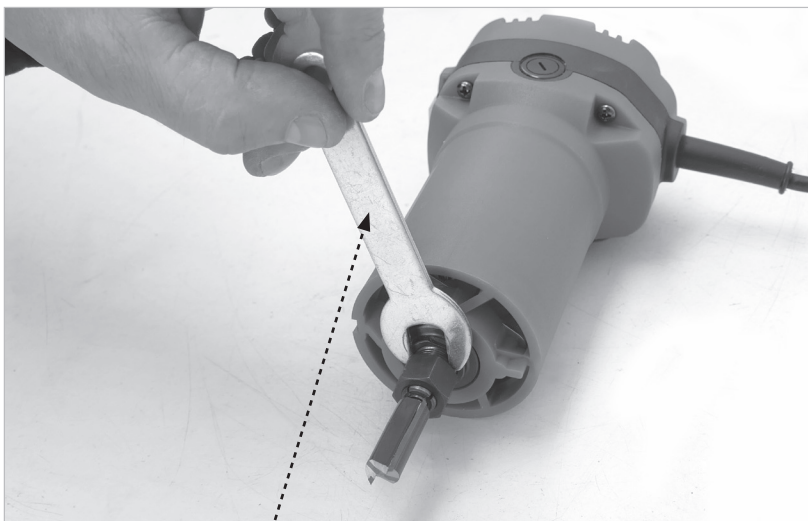

Option - Option - Option - Opțional - Opzione - Opção - Opție - Επιλογή - Opcja - Vallinnainen - Tillval -  
Допълнително - Ekstra udstyr - Opłtione - Оптация - seçenek / seçim - Volba - Volba - ראי-תע -  
Opció - Možnost - Valik - Opcija - Izvēle



**115804 :**

**Jeu de 12 fraises bois, ø 8 mm**

Set van 12 houtsnijders, ø 8 mm

Juego de 12 cortadores de madera, ø 8 mm

Conjunto de 12 cortadores de madeira, ø 8 mm

Set di 12 taglialegna, ø 8 mm

Set of 12 wood cutters, ø 8 mm







Remplacement des  
consommables  
Consumables  
replacing

**E**

02

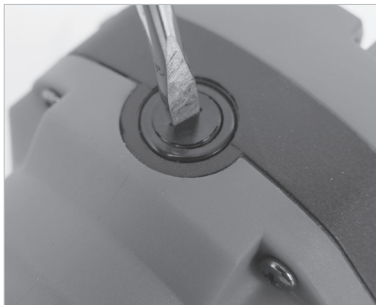
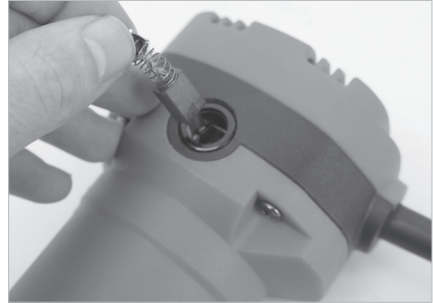
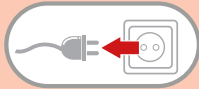



**Charbons non fournis !  
Koolborstels niet inbegrepen!  
Escobillas de carbón no incluidas!  
Escovas de carvão não incluídas!  
Spazzole di carbone non incluse!  
Carbon brushes not included!**





	<p>Tension et fréquence assignée : Nominal frequency and power: Spannung und Frequenz: Tensión y frecuencia fijada: Tensione e frequenza assegnata: Tensão e frequência fixa: Aangegeven spanning en frequentie: <b>Ονομαστική τάση και συχνότητα:</b> Napięcie i częstotliwość przydzielona: Jännite ja määrittäty taajuus: Angiven spänning och frekvens: Anført spænding og frekvens: Tensiune și frecvență de lucru:</p>	<p>Заданное напряжение и частота: Tahsis gerilimi ve frekansı: Stanovené napětí a frekvence: Stanovené napätie a frekvencia: מתח ומדר מוקצב الغلطية والذبذبة المبرمجة. Névfleges feszültség és frekvencia: Napetost in določena frekvenca: Консумирано напрежение и честота : Määratud pinge ja sagedus Nustatyta įtampa ir dažnis Noteiktāis spriegums un frekvence. Napon i nazivna frekvencija:</p>	<p>230 V ~ 50 Hz</p>
---	--	--	----------------------

	<p>Puissance assignée : Nominal power: Leerlaufdrehzahl: Potencia fijada: Potenza assegnata: Potência assinada: Onbelast toerental: <b>Ονομαστική ισχύς:</b> Prędkość na biegu jałowym: Teho: Angiven effekt: Anført styrke: Putere de lucru:</p>	<p>Заданная мощность: Tahsis edilen güç: Stanovený příkon: Predpísaný výkon: כוח מוקצב. القدرة المبرمجة. Névfleges teljesítmény : Določena jakost: Консумирана мощност: Määratud võimsus. Nustatyta galia Noteiktā jauda Nazivna snaga:</p>	<p>850 W</p>
---	---	---	--------------

	<p>Vitesse à vide : No-load speed: Drehzahl unbelastet: Velocidad vacía: Velocità a vuoto: Velocidade no vácuo: Leerlaufdrehzahl: <b>Ταχύτητα αδράνειας:</b> Prędkość bez bciążenia: Tyhjäkäyntinopeus Tomgånghastighet: Hastighed i ubelastet tilstand: Viteza în gol:</p>	<p>Скорость вращения на холостом ходу: Boşalma hızı: Rychlost naprázdno: Rýchlosť pri chode naprázdno: מהירות ריק. السرعة على الفارغ. Üres sebesség: Prosti tek: Скорост на празни обороти: Kiirus tühikäigul Tuščio prietaiso greitis Tukšgaitas ātrums Brzina praznog hoda:</p>	<p>10000 - 30000 min<sup>-1</sup></p>
---	---	---	---------------------------------------

	<p>Classe d'isolement : 2 Insulation class : 2 Isolierung Klasse : 2 Aislamiento clase :2 Isolamento classe :2 Isolamento classe :2 Isolatie Klasse : 2 <b>Κατηγορία μόνωσης: 2</b> Izolacja Klazy :2 Eristysluokka :2 Isolering Klass :2 Isoleringsklasse 2 Clasă izolație :2</p>	<p>Класс изоляции 2 : Yalıtım derecesi :2 Třída izolace :2 Izolačný systém 2 סוג בידוד :2 فئة العزل :2 Szigetelési osztály :2 Razred izolacije :2 Инструмент Клас :2 Isolatsiooniklass 2 Izolācijas rūšis 2 Izolācijas klase 2 Izolacija klasa: 2</p>	<p>X</p>
---	--	---	----------





		ø 6/8 mm
--	--	----------





		0-40 mm
--	--	---------

	<p>Lire les instructions avant usage :          Read the instructions before use :          Vor Einsatz des Geräts Anweisung lesen :          Léase las instrucciones antes de usar :          Leggere le istruzioni prima dell'uso :          Ler as instruções antes da utilização :          Lees voor het gebruik de instructies :  <b>Διαβάστε τις οδηγίες πριν από τη χρήση:</b>          Zapoznać się instrukcją przed użyciem :          Lue ohjeet ennen käyttöä :          Läs anvisningarna före användning :          læs instruktionerne før brug          Înainte de utilizare, cititi instructiunile :</p>	<p>Внимательно прочитайте следующие инструкции :          Kullanmadan talimatları okuyunuz :  <b>Pozorně si přečtete následující pokyny :</b>  <b>Pred použitím si prečítajte pokyny :</b>          זרם חילופי          اقرأ التعليمات قبل الاستخدام.  <b>használat előtt olvassuk el az utasítást :</b>  <b>Pred uporabo preberite ustrezna navodila :</b>          Прочетете указанията за употреба :          Enne kasutamist lugege instruksiooni          Prieš naudojimą perskaityti instrukciją          izlasīt instrukcijas pirms lietošanas          Pročitati upute prije uporabe:</p>	X
--	---	---	---

	<p>Conformité européenne :          Conforms to EC standards :          CE-Konformität :          Cumples con las directivas CE :          Conforme alle norme CE :          Conforme às normas CE :          Voldoet aan de EG-normen :  <b>Ευρωπαϊκή Συμμόρφωση:</b>          Zgodność z normami CE :          EU-standardien mukainen :          EU-standardien mukainen :          Overholder EU standarderne :          Conform cu normele europene:</p>	<p>соответствие европейским стандартам:          Avrupa uygunluk :          Evropská shoda :          Európska dohoda :          התאמה לתקנים האירופיים          مطابق للجواصفات الأوروبية.          Evropska ustreznost :          Európai megfeleléség :          Съответствие с европейските норми :          Euroopa Liidu vastavusmärk          Europinių normų atitikima          Atbilstība Eiropas standartiem          Europska sukladnost</p>	X
--	---	---	---

	<p>Poids :          Weight :          Gewicht :          Peso :          Peso :          Peso :          Gewicht :  <b>Βάρος :</b>          Masa :          Paino :          Vikt :          Vægt :          Greutate :</p>	<p>Бес :          Ağrlık :          Hmotnost :          Hmotnost :          משקל          الوزن.          Súly :          Teža :          Тегло :          Raskus          Svoris          Svarts          Težina:</p>	1,9 kg
--	---	--	--------



  	<p>Porter des lunettes de sécurité : Porter un masque anti-poussière: Porter une protection auditive: Wear protective eyewear : Wear a dust mask : Wear hearing protective equipment: Schutzbrille tragen : Staubschutzmaske tragen : Gehörschutz tragen: Llevar puestas gafas protectoras : Llevar puesta una careta de protección contra el polvo : Llevar puesta una protección auditiva: Portare de gli occhiali di sicurezza : Indossare una mascherina anti-polvere : Portare una protezione uditiva: Utilizar óculos de segurança : Utilizar uma máscara anti-poeira : Utilizar uma protecção auditiva: Draag een veiligheidsbril : Draag een stofmasker : Draag gehoorbeschermers: <b>Φοράτε προστατευτικά γυαλιά:</b> <b>Φορέστε μάσκα για τη σκόνη:</b> <b>Φοράτε προστασία ακοής:</b> Zakładać okulary ochronne : Zakładać maskę przeciwpyłową Zakładać słuchawki ochronne Käytä suojalaseja : Käytä pölysuojust : Käytä kuulosuojaimia: Använd skyddsglasögon : Bär mask mot damm : Bär hörselskydd: Der skal benyttes sikkerhedsbriller : Der skal benyttes beskyttelsesmaske mod støv: Der skal benyttes hørevern: Purtati ochelari de protecție : Purtati mască anti-praf : Purtati căști de protecție auz:</p>	<p>Наденьте защитные очки : Наденьте респиратор : наденьте средства звуковой защиты: Güvenlik gözlükleri takın : Toza karşı maske takın : İşitsel koruma aleti takın: Používejte bezpečnostní brýle : Používejte masku proti prachu : Používejte ochranu sluchu: Noste ochranné okuliare : Noste ochrannú masku proti prachu : Noste ochranné slúchadlá: תחייב יקשם ביכרהל אנ קבא דגנ הכסמ שובחל אנ יש ל הרכיב הגנת שמיעה حَمَلْ نَظارات وقاية. لبس قناع مضارخ للذغبار. لبس خوذة ضوضاء الضخيج. Viseljen védőszemüveget : Viseljen porvédő maszkot Viseljen fülvédőt Nositi zaščitna očala : Nositi zaščitno masko proti prahu: Nositi zašito ušes: Да се използват защитни очила : Да се използва защитна маска : Да се използва слухови защитни средства: Kandke kaitseprille Kandke tolmumaski. Kandke kõrvakaitset Nešioti apsauginius akinius Dėvėti respiratorių Nešioti apsaugą nuo triukšmo Valkāt aizsargbrilles Valkāt aizsarg masku pret putekļiem valkāt dzirdes aizsarglīdzekli Nositi zaštitne naočale: Nositi masku za zaštitu od prašine: Nositi štitnike protiv buke:</p>	X
	<p>Porter des gants : Use rubber gloves : Scchutzhandschuhe tragen : Llevar guantes de protección : Indossare i guanti di protezione : Utilizar luvas de protecção : Draag veiligheidshandschoenen : <b>Φορώντας γάντια:</b> Używać rękawic ochronnych : Käytä suojakäsineitä : Använd skyddshandskar : Der skal benyttes handsker : Purtati mănuși :</p>	<p>Наденьте перчатки : Eldiven takın : Noste rukavice : Noste rukavice : توففك شوبلا ان لبس قفازات. Viseljen kesztyű t Nositi rokavice: а се използват предпазни ръкавици : Kandke kindaid Müvēti pirštines Valkāt cimdus Nositi zaštitne rukavice:</p>	X







	<p>Soumis à recyclage Subjected to recycling Sujeto a reciclaje Sottoposti a riciclaggio Sujeitos à reciclagem Não deite no lixo Niet wegwerpen Υπόκειται σε ανακύκλωση Nie wyrzucac Älä heitä pois luontoon Batteriet får inte kastas Bortkast det ikke Nu le auncati</p>	<p>Подлежит переработке Atmayiniz Nevyhaziute je do bežného odpadu Neodhadzovat Gjennvinningspliktig فلا ترمدها هنا في القمامة. ne mečite1 Ne odvržite ga/jih vstran Taaskasutusse kuuluv Ärge visake seda minema Nemetykite Nemest Podvrgnuto recikliranju</p>	×
---	--	---	---

**Recyclage des déchets :**

Les outils, accessoires et leur emballages doivent suivre une voie de recyclage adaptée. Conformément aux directives Européenne 2012/19/UE et 2006/66/CE, les composants d'un produit doivent être séparés, collectés, recyclés ou éliminés en conformité avec les réglementations environnementales en vigueur. Les appareils, batteries, piles, huiles, emballages devront être déposés dans les systèmes d'élimination des déchets spéciaux tels que déchetteries. Renseignez-vous auprès de votre commune pour connaître l'organisme le plus proche à même de retraiter ou de collecter ces déchets.

	<p>Recyclable, soumis au tri sélectif Recyclable, subject to recycling Recyclingfähige, unterliegen Recycling Reciclables, sujetos a reciclaje Riciclabili, soggetti a riciclaggio Recicláveis, sujeito à reciclagem Recycleerbare, onderworpen aan recycling Ανακυκλώσιμο, υπόκειται σε επιλεκτική διαλογή Opakowanie nadaje się do recyklingu podlegają recyklingu Kierrätettävien pakkausten kohteena kierrätys Återvinningsbara förpackningar omfattas återvinning Рециклираци се опаковки подлежат на рециклиране Genanvendelig underlagt genbrug</p>	<p>Reciclabile sub rezerva reciclare Повторно упаковка подлежит вторичной переработке Geri dönüŝüm Geri dönüŝtürülebilir ambalaj konusu Recyklovateľné podliehajúci recyklácii Recyklovateľné podliehajúce recykláciiu Resirkulerbar, med forbehold om selektiv sortering ريوسللا خا مال غير ريوستلا خا مال لياؤلا نيل نيل او نوب نيل Újrahasznosítható csomagolás alá újrahasznosítás Reciklirati predmet recikliranja Pakendite suhtes ringlussevõtu Pärsträdājams iepakojumus otrreizējai pārstrādei Perdirbamų taikomos perdirbimo Može se reciklirati, podložno selektivnom sortiranju</p>	×
---	--	---	---



 <b>L<sub>pA</sub></b>	Niveau de pression acoustique :	Уровень акустического давления. :	81 dB (A)
	Acoustic pressure level :	Akustik basınç seviyesi :	
	Schalldruckpegel :	Hladina akustického tlaku :	
	Nível de presión acústica :	Hladina akustického tlaku :	
	Livello di pressione acustica :	רמת לחץ אקוסטי.	
	Nível de pressão acústica :	مستوى الضغط السمعي.	
	Niveau akoestische druk :	A hangnyomás szintje :	
	<b>Στάθμη ηχητικής πίεσης:</b>	Nivo akustičnega pritiska:	
	Poziom mocy akustycznej :	Равнище на акустично налягане :	
	Käytä kuulosoajimia :	Helirõhu nivoo	
Ljudtryksnivå :	Akustinio spaudimo lygis		
Lydtryk :	Akustiskā spiediena līmenis		
Nível presiune acustică :	Razina zvučnog tlaka:		

 <b>L<sub>wA</sub></b>	Niveau de puissance acoustique :	уровень мощности звука :	89 dB (A)
	Acoustic power level :	Akustik basınç seviyesi :	
	Schalleistungspegel :	Hladina zvukového výkonu :	
	Nível de potencia acústica :	Hladina zvukového výkonu :	
	Livello di potenza acustica:	רמת כוח אקוסטי.	
	Nível de potência acústica:	مستوى الصوتي.	
	Niveau akoestisch vermogen :	a hangnyomás szintje :	
	<b>Επίπεδο ισχύος ήχου:</b>	Nivo akustične jakosti :	
	Poziom mocy akustycznej :	Равнище на вибрации :	
	Käytä suojalaseja :	Helivõimsuse nivoo	
Ljudstyrkenivå :	Triukšmo lygis		
Lydstyrke :	Akustiskās jaudas līmenis		
Nível putere acustică :	Razina zvučne snage:		

NIVEAU SONORE D'ÉMISSION :

A VIDE

Pression acoustique L<sub>pA</sub> poste opérateur  
Incertitude

81 dB  
3

Puissance acoustique L<sub>wA</sub>  
Incertitude

89 dB  
3

Valeurs déterminées suivant le code d'essai de l'annexe B de la norme EN 61029-1 avec emploi des normes de base ISO 11201 et ISO 3744.

Les niveaux de pression acoustique obtenus in situ dépendent :

- Des niveaux réels de la machine considérées, en prenant en compte les incertitudes déclarées;
  - Du local et de l'installation de la machine. Préférez une pièce dont l'acoustique est plus feutrée.
- Evaluez les pièces vide à grande résonance. Placez vous auprès d'une fenêtre le cas échéant.
- Des outils montés, des pièces travaillées, des réglages choisis,...

 <b>L<sub>v</sub></b>	Niveau de vibration :	Уровень вибрации :	2,5 m / s <sup>2</sup>
	Hand/arm vibration level :	Titreşim seviyesi :	
	Vibrationspegel Hand/Arm :	Úroveň vibrací :	
	Nível de vibración mano/brazo :	Hladina vibrácií :	
	Livello di vibrazione mano/braccio :	רמת תנודות	
	Nível de vibração mão/braço :	مستوى الارتجاج.	
	Trillingsniveau hand/arm :	Vibrációsziint :	
	<b>Επίπεδο κραδασμών:</b>	Nivo vibracij :	
	Poziom wibracji rżka/ramię :	Равнище :	
	Tärinätsato:	Vibrācijas līmenis.	
Vibrationsnivå hand/arm :	Vibracijos lygis		
Vibrations niveau :	Vibratsioonini nivo		
Nível vibrații :	Razina vibracije:		

VIBRATIONS:

Total des valeurs de vibration (somme vectorielle des trois directions) déterminée selon EN 60745 :

a 2,5 m/s<sup>2</sup>  
Incertitude K 1,5 m/s<sup>2</sup>

L'amplitude d'oscillation peut être utilisée comme valeur de comparaison d'outils électroportatifs.

Attention : si l'outil électroportatif est utilisé pour d'autres applications, avec d'autres outils de travail, l'amplitude d'oscillation peut être différente.





AE 850

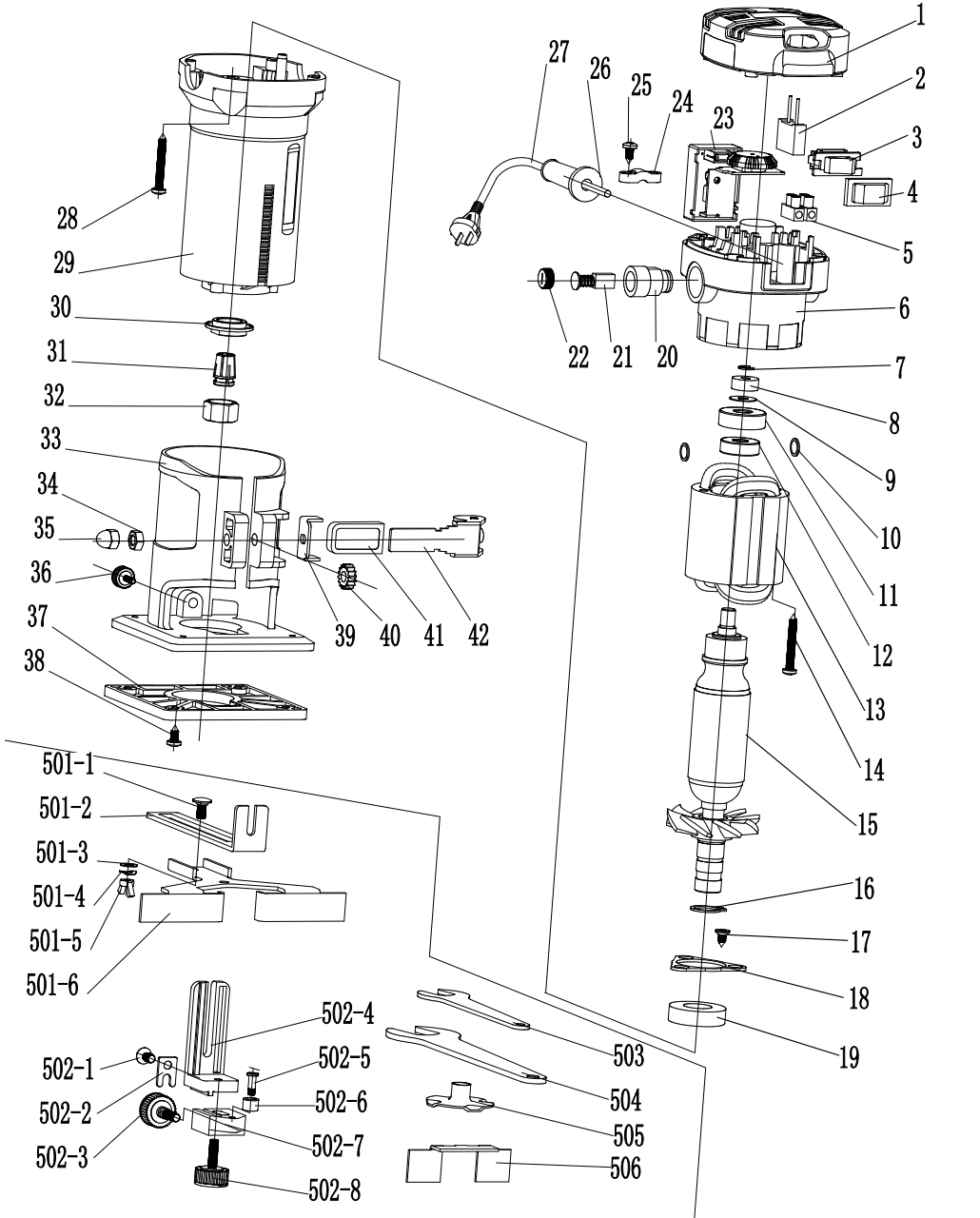

DECLARATION DE CONFORMITE  
VERKLARING VAN OVEREENSTEMMING  
DECLARACION DE CONFORMIDAD  
DICHIARAZIONE DI CONFORMITA  
KONFORMITÄSERKLÄRUNG  
DECLARATION OF CONFORMITY  
DECLARAÇÃO DE CONFORMIDADE  
DEKLARACJA ZGODNOSCI Z NORMAMI  
OM ÖVERENSSTÄMMELSE  
VAATIMUSTENMUKAISUUSVAKUUTUS  
ÖVERENSSTÄMMELSESERKLÄRING  
Dĭl'vsh symmŏrwvshzsymmŏrwvshz

DECLARAȚIE DE CONFORMITATE  
VYHLÁSENIE ZHODY  
Декларация соответствия  
SAMSVARERKLÆRING  
Uygünlük beyanı  
الخصمىح بالمطابق ة  
PROHLÁŠENÍ SHODY  
EGYZŐSÉGI NYILATKOZAT  
Декларация за съответствие с нормите  
IZJAVA O SKLADNOSTI  
DEKLARACIJA  
ATTITIKIES DEKLARACIJA  
KINNITUS  
IZJAVA O SUKLADNOSTI

Le soussigné,  
Ondergetekende,  
Der Unterzeichner,  
O abaixo assinado,  
Undertecknad,  
Долуподписаният  
Undertegnede  
Subsemnatul,  
Я, нижеподписавшийся,  
Imzalayan,  
Niže podepsany,  
Toliau pasirašęs

Personne autorisée à constituer  
le dossier technique :  
Christophe HUREL



FAR GROUP EUROPE  
192, Avenue Yves Farge  
37700 St. Pierre-des-Corps  
FRANCE

El suscrito,  
Il sottoscritto,  
The undersigned,  
Níneí podpísany,  
Allékirjoittanut,  
Ο κáτωθι υπογραμμένος,  
Nižsie podpísany  
Undertegnede,  
الخصمىع انداءه  
Alulírott,  
Podpisani,  
Apakša parakstijies  
allakirjutanu  
Dolje potpisani,

Declara por la presente que,  
Dichiare che,  
Declares that,  
Oowiadzca niniejszym, że  
Ilmoitetaan täten että,  
Dhlonei me thn Paroysa  
tynto vyhlasuje, že

يخصمىع اسبنداءا على ذلك  
kijelentem, hogy a készülék Izjavlja da,  
Pareiskia, kad,  
Ar šo apliecinā, ka,  
Kinnitab, et  
Izjavljuje u ovom dokumentu da je

Déclare par la présente que,  
Verklaart hiermede dat,  
Erklärt hiermit daß,  
Declara pela presente que,  
Förklarar härmed att  
Заявява с настоящото  
erklærer hermed, at  
Declara prin prezenta că,  
настоящим подтверждаю, что  
Mevcut belgeyle beyan ediliyor ki,  
tımto prohlasuje, že,  
Pareiskia, kad,

Affleureuse électrique / Electric trimmer / Elektrische Oberfräse / Anuradora eléctrico / Fresatrice elettrico / Тупіа електрична / Elektrische Bovenrees /  
Ηλεκτρικός βρομολογητής / Router elektryczny / Sähköinen reititin / Elektrisk router / Электрически рутер / Elektrisk router / Ruter electric /  
Электрический маршрутизатор / Elektrikli yönlendirici / Elektrická horní frézka / Elektrická horná frézovačka na drevo / إلمشع بنا / Elektrisk router /  
Električni usmerjevalnik / Elektriline ruuter / Elektriskais maršrutētājs / Elektrinis maršrutizatorius / Električni usmerjevač

## code

FARTOOLS / 115400 / AE 850 / 3106T

Est conforme et satisfait aux directives et normes CE,  
In overeenstemming is met en Voldoet aan EG richtlijnen,  
Den folgenden EU-Bestimmungen entspricht,  
Respeita e está em conformidade com as normas CE,  
Överensstämmer med och uppfyller EG-standarder,  
Съответства и отговаря европейските норми  
Er i overensstemmelse med og overholder EU standarderne  
Este conform și satisface normele CE  
полностью соответствует и удовлетворяет  
требованиям стандартов ЕС  
CE şartlara uygundur,  
odpovídá normám ES.  
Atitinka ir atitinka EB direktyvas ir standartus,

Cumple con la directivas de la CE,  
E conforme alle direttive CEE,  
Complies with the EEC directives and standards,  
Odpowiada normom UE,  
Täyttää EU-vaatimukset,  
Συμμορφώνεται και ικανοποιεί τις οδηγίες και τα πρότυπα CE,  
zodpovedá normám ES.  
Samsvarer med og tilfredsstiller CE-direktiver og standarder,  
بان الچهاز مطابق و یلدی معایبر مع جوهرة الدول الاوروبیة  
kielegiti a CE szabványok előírásait.  
Je v skladu z in izpolnjuje norme Evropske skupnosti.  
Atbilst un atbilst EK direktivas un standartus,  
Vastab ja vastab EU direktiividele ja standarditele,  
Sukladan i ispunjava direktive i standarde CE,

2006/42/EC 2014/30/EU 2011/65/EU 2015/863/EU

EN62841-1:2015+A11:2022  
EN62841-2-17:2017  
EN IEC55014-1:2021  
EN IEC55014-2:2021  
EN IEC61000-3-2:2019+A1:2021  
EN61000-3-3:2013+A1:2019+A2:2021

Christophe HUREL,  
Président Directeur Général  
19/12/2022  
Fait à St. Pierre-des-Corps





115400-Sticker-A-03-Logo.indd 14/12/2022 11:27



115400-Sticker-A-04-Features.indd 14/12/2022 11:26



115400-Sticker-A-05-Nomres.indd 1 15/12/2022 11:05



## GARANTIE - WARRANTY



### RO. GARANTIE

Acest aparat este garantat din punct de vedere contractual impotriva tuturor viciilor de constructie si de material, incepand de la data vanzarii lui catre utilizator si la simpla prezentare a bonului de casa. Garantia consta in inlocuirea componentelor defecte. Aceasta garantie nu se aplica in cazul exploatarii in alt mod decat cel recomandat de normele aparatului si nici in caz de stricaciuni provocate de interventii neautorizate sau prin neglijenta cumparatorului. Garantia nu se aplica asupra pagbelor cauzate de o defectare a aparatului.

### RU. ГАРАНТИЯ

Данное изделие обладает имеющей силой контракта гарантией, покрывающей все возможные дефекты изготовления материала. Гарантия вступает в силу с даты продажи изделия пользователю, для этого достаточно сохранить и предъявить полученный в кассе чек. Гарантия обязывает изготовителя заменить дефектные части изделия. В случае не соответствующего нормам использования изделия, несанкционированного демонтажа или ремонта или небрежного обращения действие гарантии прекращается. Гарантия не покрывает ущерба, возникшего в результате сбоя в работе изделия.

### TU. GARANTIA

Bu arac, satis tarihinden itibaren, kullanicinin sadesce vezne alindisini sunmasiyyla tum uretim ve malzeme hatasina karsi garantilidir. Garanti eksik olan kisimlari degistirir. Bu garanti aracin sartlarina uygun olmayan isleme durumunda, izin verilmeyen kullanimlardan kaynaklanan hasarlarda veya alcinin istegi durumunda uygulanmaz. Garanti malzemenin bir eksikliginden meydana gelen bir zararda uygulanmaz.

### CS. ZÁRUKA

Pro tento nástroj platí smluvní záruka na všechny výrobní a materiálové vady od data prodeje uživateli a na základě předložení pokladního bloku. Záruka spočívá ve výměně vadných částí. Tato záruka neplatí v případě použití přístroje, které neodpovídá normám, ani v případě škod způsobených nepovolenými zásahy nebo nedbalostí ze strany kupujícího. Záruka se nevztahuje na škody způsobené závadou nástroje.

### SK. ZÁRUKA

Pre tento nástroj platí zmluva

vná záruka na všechny výrobné a materiálové chyby od dátumu predaja užívateľovi a na základe predloženia pokladničného bloku. Záruka spočíva vo výmene chybných častí. Táto záruka neplatí v prípade použitia prístroja, ktoré nezodpovedá normám, ani v prípade škod spôsobených nepovolenými zásahmi alebo nedbalosťou zo strany kupujúceho. Záruka sa nevzťahuje na škody spôsobené poruchou nástroja.

### HE. GARANTIA

הצגת המכונה תהיה מוגנת באחריות-משמעה בחומר, החל מיום המכירה למשתמש עם אחריות לפי חוזה מפי כל לקי ביצור או על ידי התערבות תלם הי עלכל זה חלה שאינו מתאים לתקנים ובמקרה של נזק שנגרם זו אינה חלה במקרה של שימוש במכשיר תקלה בכלי. החלף תחלקם הקלויים אחריות האחריות אינה חלה על נזק שנגרם על ידי סמכות או על ידי רשלנות מאת הקונה.

### AR. الضمان

على مجرد تقديم بطاقة الشراء يتعلّق من تاريخ البيع إلى المستعمل وبنءا على فني التصنيّ عوفى الجوانب، اعتباراً أنّ هذه ألء دة مضمونة تعاقدياً من أي الجوانب، ولأ فسيءة تعرضه لتللفات الرءة الأساسيّة غير المطابق لمعايير الء يكون هذا الضمان قابلاً للتطبيق في ظلّ الضمان فءى سبب الء الءءاءة الءءة الء ينطبق الضمان على الضمير الءءء عن عرضة أو فسيءة الءءء من قبل المشتري بءءة عن علوءات تدخّل غير

### HU. GARANCIA

Erre a szerszámra szerződéses garanciát vállalunk bármilyen gyártási és anyaghiba felmerülése esetére, a fogyasztó részére történt eladás napjától számítva, a penztári blokk egyszerű felmutatása ellenében. A garancia a hibás alkatrészek cseréjére terjed ki. Ez a garancia nem érvényes, ha a készüléket nem rendeltetésszerűen használták, sem illetéktelen beavatkozások, vagy a vásárló hanyagsága okozta károk esetén. A garancia nem fedezi azokat a károkat, melyeket a szerszám hibás működése okozott.

### SI. GARANCIJA

To gorodje je z garancijsko pogodbo zašciteno proti vsem napakam v izdelavi in v sestavnem materialu od datuma prodaje naprej in ta velja ob predložitvi blagajniškega računa. Garancija velja za zamenjavo delov z napako. Ta garancija ne velja za uporabo orodja, kj ni v skladu z normami, predpisanimi za omenjeno orodje in za primere okvar, ki nastanejo zaradi nedovoljenih posegov na orodju ali zaradi malomarnega rokovanja kupca. Garancija ne velja za škodo, ki jo lahko povzroči okvara orodja.

### ET. GARANTII

See toorist kuulub lepingu järgi garantiiremonti arvestades alates muutmise päevast ja kassatseki alusel kasutajale koigi konstruktsiooni- ja materjalivigade puhul. Garantii

seisneb defektsete osade väljavahetamisest. See garantii ei kehti aparadi normide ebatavalise eiramise puhul ega ostja poolt keelatud viisil kasutamiseist või hooletussejätmisest tulenevate kahjude korral. Garantii ei kehti seadme defektidest põhjustatud kahjude puhul.

### LV. GARANTĪJA

Sis prietaisus yra uztikrinamas kaip itin geros kokybes, nuo jo pardavimo datos iki jo panaudojimo, ir jam yra suteikiamas garantinis taikomas. Garantijos metu galima pakeisti atsiradusius trumplaiakius gedimus. Si garantija netaikoma esant netinkamam naudojimui ar nesilaikant reikiam sio aparato vartojimo instrukciju, tai pat paciam pirkeju ji sugadinusi. Garantija taip pat netaikoma, prietaisa naudojant ne pagal paskirti ir ji apgadinus.

### LT. GARANTUJA

Sim darbarikam ir liguma noteikta garantija visiem defektiem, kas saistās ar konstrukciju un materiālu, sakot ar pārdošanas datumu, kad mašīnu, pardot lietotājam un vienkarši uzrādot kases čeku. Garantija iekļauj bojāto daļu nomaiņu. Si garantija nav derīga, ja aparāts nav lietots saskaņā ar drošības noteikumiem, ne gādājums ja bojājumi radusies nesāncionētas, iekļausanas gadijuma vai arī pircēja nolaidības dēļ. Garantija nav derīga, ja bojājumi radusies darbarikā defekta dēļ.

### HR. JAMSTVO

Ovaj alat ima ugovorno jamstvo u slucaju bilo kakvih nedostataka u konstrukciji i materijalu, od datuma prodaje korisniku uz jednostavno predocenje racuna. Jamstvo se sastoji u zamjeni neispravnih dijelova. Ovo je jamstvo ne primjenjuje u slucaju uporabe i eksploatacije koja nije sukladna standardima uređaja, niti u slucaju štete uzrokovane neovlaštenim intervencijama ili nemarkom kupca. Jamstvo se ne primjenjuje na štetu uzrokovanu nekim nedostatkom alata.

## SERVICE APRÈS VENTE - AFTER SALE SERVICE

FARGROUP EUROPE - 192, Avenue Yves Farge - 37700 St. PIERRE-des-CORPS - FRANCE  
fargroup@fargroup.net

## GARANTIE - WARRANTY



### FR. GARANTIE

Cet outil est garanti contractuellement contre tout vice de construction et de matière, à compter de la date de vente à l'utilisateur et sur simple présentation du ticket de caisse. La garantie consiste à remplacer les parties défectueuses. Cette garantie n'est pas applicable en cas d'exploitation non conforme aux normes de l'appareil, ni en cas de dommages causés par des interventions non autorisées ou par négligence de la part de l'acheteur. La garantie ne s'applique pas sur les dommages causés par une défaillance de l'outil.

### DE. GARANTIE

Die Garantiezeit für dieses Gerät in Bezug auf Konstruktions- und Materialfehler beträgt lt. Vertrag bei Vorlage des Kassabons. Die Garantieleistung besteht im Ersatz schadhafter Teile. Die Garantie erlischt bei einem Einsatz des Geräts, der nicht normentsprechend ist, bei Schäden, die auf unsachgemäße Eingriffe zurückzuführen sind bzw. bei Nachlässigkeit seitens des Käufers. Die Garantie erstreckt sich nicht auf Schäden, die auf Fehlfunktionen des Geräts zurückzuführen sind.

### IT. GARANZIA

Quest' attrezzo è garantito per contratto contro qualsiasi difetto di costruzione e di materia, a partire dalla data di vendita all'utente e su semplice presentazione dello scontrino. La garanzia consiste nel sostituire le parti difettose. Questa garanzia non è applicabile in caso di struttamento non conforme alle norme dell'apparecchio, né in caso di danni causati da interventi non autorizzati o da negligenza da parte dell'acquirente. La garanzia non si applica ai danni causati da un'avarìa dell'attrezzo.

### EN. GARANTIE

This tool is guaranteed, in writing, against any defect in manufacture or parts from the date of sale, upon simple presentation of the sales slip. The guarantee is limited to the replacement of faulty parts. This guarantee is not applicable in the event of usage which is not conform with the intended usage of the apparatus, nor in the event of damage caused by unauthorised servicing or negligence on behalf of the purchaser. This guarantee does not apply to any damage caused by the failure of this tool.

### ES. GARANTIA

Esta herramienta se garantiza contractualmente contra todo defecto de construcción y materia, a partir

de la fecha de venta a l' usuario y sobre simple presentación del recibo de caja. La garantía consiste en sustituir a las partes defectuosas. Esta garantía no es aplicable en caso de explotación no conforme a las normas del aparato, ni en caso de daños causados por intervenciones no autorizadas o por negligencia por parte del comprador. La garantía no se aplica sobre los daños causados por un fallo del herramienta.

### NL. GARANTIE

Dit gereedschap heeft een garantie tegen constructeurfouten en materiaaldefecten, die geldig is vanaf de aankoopdatum door de gebruiker, op vertoning van de kassabon. De garantie betreft de vervanging van de defecte onderdelen. Deze garantie is niet van toepassing indien het apparaat niet volgens de normen gebruikt is, noch in geval van schade veroorzaakt door onbegrijpelijk gebruik of nalatigheid van de koper. De garantie is niet van toepassing op schade voortvloeiend uit een defect van het gereedschap.

### PT. GARANTIA

Esta ferramenta tem uma garantia contratual contra qualquer defeito de construção e de material, a partir da data de venda ao utilizador e sobre simples apresentação do talão da caixa. A garantia consiste em substituir as partes defeituosas. Esta garantia não é aplicável no caso de exploração não conforme as normas do aparelho, nem em caso de danos causados pelas intervenções não autorizadas ou por negligência da parte do comprador. A garantia não se aplica para os danos causados por uma falha da ferramenta.

To ergale9io avt9o f9ere  
symbatik9h egg9yhsz gia  
oPoiod9hPote el9attvma  
kataskeyhz aP9o thn  
hmeromhyia p9vlihozh sto  
x9hstih me aP19h Prosk9omish  
thz aP9o-oeihz agor9az. H  
egg9yhsz aPotele9itai att9o  
thn antikata9oatoh tvn  
elattvmatik9vn tmhm9atvn.  
H Paro9yssa. egg9yhsz oep  
ewarm9ozetai se Per9iPvsh  
x9hshz mh szymvwnhz me  
ta Pr9otyPa thz syskem9hz.  
h se Per9iPtvszh zhmi9az.  
Poy Prok19hUkhe aP9o mh  
egkekrim9enn eP9embash  
9h aP9o am9eleia toy  
agorast9h. H egg9yhsz Ooeh  
ewarm9ozetai se zhmi9ez Poy  
Prokalo9yntai aP9o bl9abh toy  
ergale9ioy. Stavro9i keno9y  
Diasthmo2Par9embvysma

### PL. GWARANCJA

Narz dzie jest obte gwarancja na wszelkie wady konstrukcyjne i materialowe, liczac od daty sprzeday uytownikowi. I po okazaniu paragonu kasowego. Gwarancja obejmuje wymiany cz-Aci wybrakowanych. Gwarancja nie

znajduje zastosowania w przypadku uytkowania niezgodnego z normami urzadzenia, ani w przypadku szkod spowodowanych zaniedbaniami ze strony nabywcy. Gwarancja nie obejmuje szkod powstalych z powodu upadku urzadzenia.

### SV. GARANTI

Detta verktyg har en avtalsenlig garanti mot konstruktions- och materialfel, från och med tidpunkten för användarens inköp och genom uppvisning av kassakvittot. Garantin består i att ersätta de bristfälliga delarna. Denna garanti gäller inte om användningen inte följer apparatens standarder, inte heller vid skador som orsakas av ej tillåtna ingrepp eller på grund av koparens vårdslöshet. Garantin gäller inte forskador som orsakats av att verktyget fungerat bristfälligt.

### FI. TAKUU

Taman laitteen takuu on voimassa sopimuksenmukaisesti kattaen kaikki rakenne- ja materiaali- ja lukien ostopaivasta kassakuittia vastaan. Takuu sisältää viallisten osien korvaamisen. Takuu ei korvaa ohjeidenvastaista käyttöä eikä ylituuttamattomien henkilöiden käsittelystä tai ostajan huolimattomuudesta aiheutuneita vahinkoja. Takuu ei vastaa myöskään toimintahäiriöistä aiheutuneita vahinkoja.

Този инструмент е под договорна гаранция срещу всякакъв дефект в изработката и използваните материали, считано от датата на продажба на потребителя и само срещу представяне на касовата бележка. Гаранционното обслужване се състои в замяна на дефектните части. Настоящата гаранция не е валидна когато апаратът се използва по начин, несъответстващ на стандарта за работа с него, както и в случай на щети, нанесени от неотризири лица, или вследствие на проявена небрежност от страна на потребителя. Гаранцията не покрива щети, произтекли вследствие на техническа неизправност на апарата.

### DA. GARANTI

Dette værktøj er dækket af en garantikontrakt for konstruktions- og materialefejl, som gælder fra købsdatoen ved visning af kassebonen. Garantien består i at udskifte de defekte dele. Garantien dækker ikke fejl opstået som følge af anvendelse, som ikke overholder standarderne for apparatet, eller skader opstået ved ikke autoriserede indgreb eller sløshed fra brugerens side. Garantien dækker ikke skader opstået, fordi værktøjet har svigtet.

## SERVICE APRÈS VENTE - AFTER SALE SERVICE

FARGROUP EUROPE - 192, Avenue Yves Farge - 37700 St. PIERRE-des-CORPS - FRANCE

fargroup@fargroup.net



## FAR GROUP EUROPE

Une société du groupe **SIGMA**

192, Avenue Yves Farge  
37700 St. Pierre-des-Corps  
FRANCE

[fartools.com](http://fartools.com)

