



- FR** Mini meuleuse (Notice originale)
- EN** Mini grinder (Original manual translation)
- DE** Mini-Schleifmaschine
- ES** Mini esmeriladora (Traducción del manual de instrucciones originale)
- IT** Mini molatrice (Traduzione dell'avvertenza originale)
- PT** Mini esmerilador (Tradução do livro de instruções original)
- NL** Kleine slijpmachine
- EL** ΜΙΝΙ ΜΥΛΟΣ (ΑΥΘΕΝΤΙΚΟ ΕΓΧΕΙΡΙΔΙΟ)
- PL** Mini szlifierka
- FI** Pienoishiomakone
- SV** Miniatyrslipmaskin
- BU** МИНИ ТОЧИЛО
- DA** Mini slibemaskine
- RO** Minipolizor
- RU** МИНИ-шлифовальный станок
- TU** mini oğütücü
- CS** kufříková mini bruska
- SK** kufříková mini brúsk
- HE** הנחשם ינימ
- AR** قري غص ةخالج
- HU** Mini köszörűgép
- SL** Mini brusilni
- ET** Väikejahvatusmasin kohvris
- LV** Mini slīpmašīna somā
- LT** maža malimo mašinėlė
- HR** Mini brusilica (Originalni priručnik)



DCP 170
Professional Machine



© FAR GROUP EUROPE

115426-Manual-B-20220302



fartools.com



5 min





Description et repérage des organes de la machine
Description and location of machine parts

A



Contenu du carton
Contents of box

C

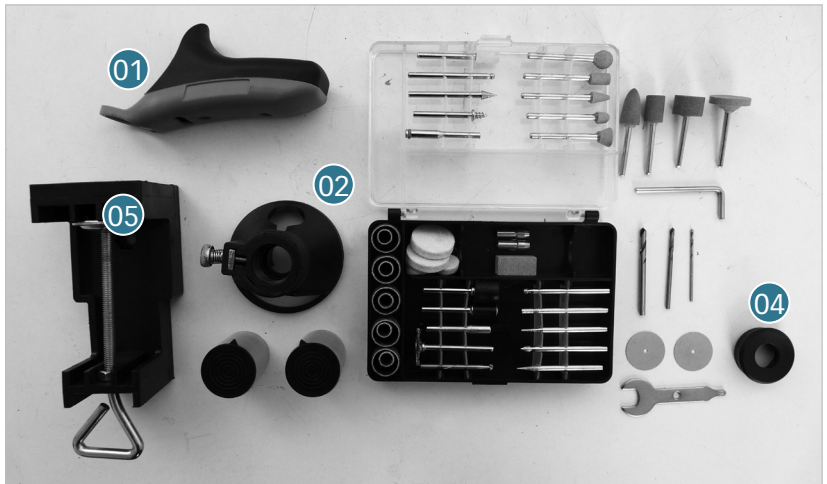

Points de collecte sur www.quefaire-demadchets.fr
Privilégiez la réparation ou le don de votre appareil !





Assemblage de la machine
Assembling the machine

D

DCP 170





Assemblage de la machine
Assembling the machine

D

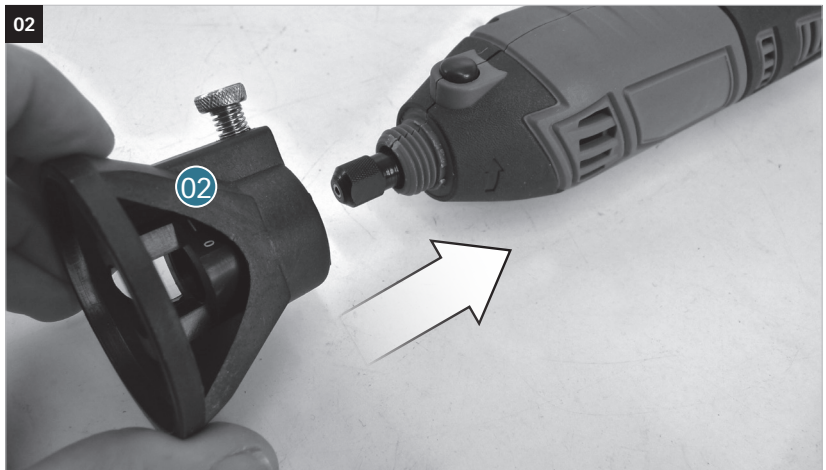



Assemblage de la machine
Assembling the machine

D

DCP 170

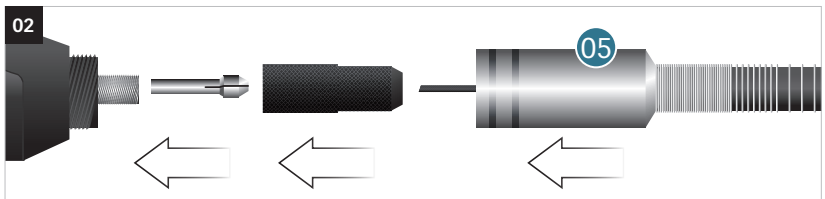
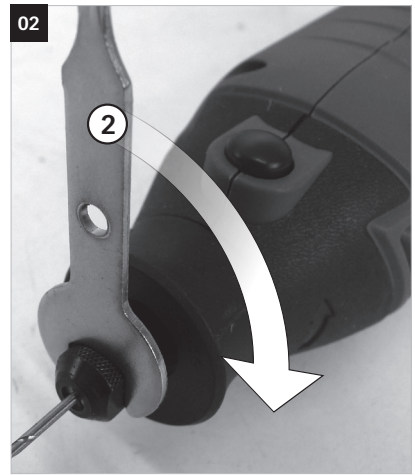
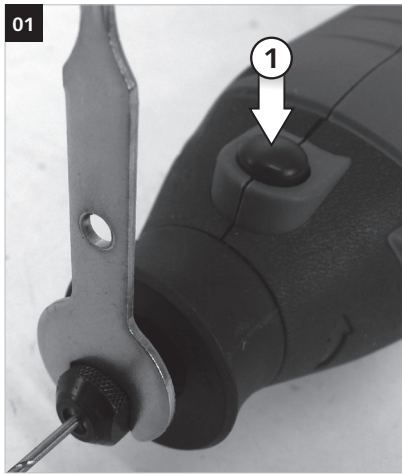



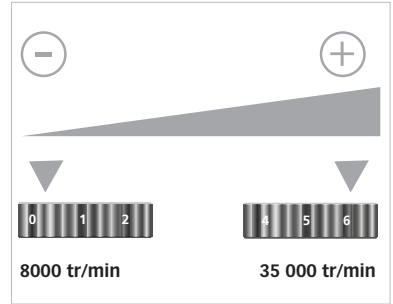
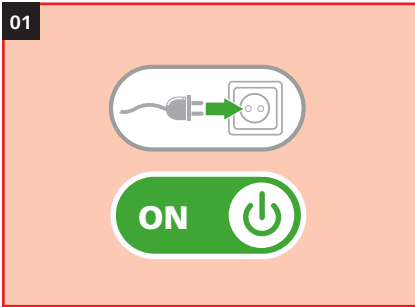

Fonctionnalité de la machine
Functions of the machine

E





	<p>Tension et fréquence assignée: Nominal frequency and power: Spannung und Frequenz: Tensión y frecuencia fijada: Tensione e frequenza assegnata: Tensão e frequência fixa: Aangewezen spanning en frequentie: ΟΝΟΜΑΣΤΙΚΗ ΤΑΣΗ ΚΑΙ ΣΥΧΝΟΤΗΤΑ: Napięcie i częstotliwość przydzielona: Jännite ja määrittäty taajuus: Angiven spänning och frekvens: Anført spænding og frekvens: Tensiune și frecvență de lucru:</p>	<p>Заданное напряжение и частота: Tahsis gerilimi ve frekans: Stanovené napětí a frekvence: Stanovené napätie a frekvencia: מתח ותדר מוקצב. الغلطية والذبذبة المبرمجة. Névleges feszültség és frekvencia: Napetost in določena frekvenca: Консумирано напрежение и честота : Määratud pinge ja sagedus Nustatyta įtampa ir dažnis Noteiktais spriegums un frekvence. Nazivni napon i frekvencija</p>	230 V ~ 50 Hz
---	--	--	---------------

	<p>Puissance assignée: Nominal power: Leerlaufdrehzahl: Potencia fijada: Potenza assegnata: Potência assinada: Onbelast toerental: ΟΝΟΜΑΣΤΙΚΗ ΙΣΧΥΣ: Prędkość na biegu jałowym: Teho: Angiven effekt: Anført styrke: Putere de lucru:</p>	<p>Заданная мощность: Tahsis edilen güç: Stanovený výkon: Predpísaný výkon: כוח מוקצב. القدرة المبرمجة. Névleges teljesítmény : Določena jakost: Консумирана мощност: Määratud võimsus. Nustatyta galia Noteiktā jauda Nazivna snaga:</p>	170 W
---	---	---	-------

	<p>Vitesse à vide: No-load speed: Drehzahl unbelastet: Velocidad vacía: Velocità a vuoto: Velocidade no vácuo: Leerlaufdrehzahl: ΤΑΧΥΤΗΤΑ ΑΔΡΑΝΕΙΑΣ: Prędkość bezciążenia: Tyhjääntinnopeus Tomgånhastighet: Hastighed i ubelastet tilstand: Viteza în gol:</p>	<p>Скорость вращения на холостом ходу: Boşalma hızı: Rychlost naprázdno: Rýchlosť pri chode naprázdno: מהירות ריק. السرعَة على الفارغ. Üres sebesség: Prosti tek: Скорост на празни обороти: Kiirus tühikäigul Tuščio prietaiso greitis Tukšgaitas ātrums Brzina u praznom hodu:</p>	8000 - 35000 min ⁻¹
---	---	--	--------------------------------

	<p>Classe d'isolement : 2 Insulation class : 2 Isolierung klasse : 2 Aislamiento clase :2 Isolamento classe :2 Isolamento classe :2 Isolatie Klasse : 2 ΚΑΤΗΓΟΡΙΑ ΜΟΝΩΣΗΣ: 2 Izolacja Klazy :2 Eristysluokka :2 Isolering Klass :2 Isoleringssklasse 2 Clasă izolatție :2</p>	<p>Класс изоляции 2 : Yalıtım derecesi :2 Třída izolace :2 Izolačný systém 2 סוג בידוד :2 فئة العزل :2 Szigetelési osztály :2 Razred izolacije :2 Инструмент Клас :2 Isolatsiooniklass 2 Izolācijas rūšis 2 Izolācijas klase 2 Klasa izolacije: 2</p>	X
---	---	---	---





	<p>Conformité européenne Conforms to EC standards : CE-Konformität : Cumples con las directivas CE : Conforme alle norme CE : Conforme às normas CE : Voldoet aan de EG-normen : ΕΥΡΩΠΑΪΚΗ ΣΥΜΜΟΡΦΩΣΗ Zgodność z normami CE : EU-standardien mukainen : EU-standardien mukainen : Overholder EU standarderne : Conform cu normele europene:</p>	<p>соответствие европейским стандартам: Avrupa uygunluk : evropská shoda : európska dohoda : התאמה לתקנים האירופיים مطابق للمواصفات الأوروبية. evropska ustreznost : európai megfeleléség : Съответствие с европейските норми : Euroopa Liidu vastavusmärk Europinių normų atitikima Atbilstība Eiropas standartiem Europska sukladnost</p>	X
---	---	---	---

	<p>Lire les instructions avant usage : Read the instructions before use : Vor Einsatz des Geräts Anweisung lesen : Léase las instrucciones antes de usar : Leggere le istruzioni prima dell'uso : Ler as instruções antes da utilização : Lees voor het gebruik de instructies : ΔΙΑΒΑΣΤΕ ΤΙΣ ΟΔΗΓΙΕΣ ΠΡΙΝ ΑΠΟ ΤΗ ΧΡΗΣΗ: Zapoznać się z instrukcją przed użyciem : Lue ohjeet ennen käyttöä : Läs anvisningarna före användning : læs instruktionerne før brug Înainte de utilizare, citiți instrucțiunile :</p>	<p>Внимательно прочитайте следующие инструкции : Kullanmadan talimatları okuyunuz : Pozorně si přečtete následující pokyny : Pred použitím si prečítajte pokyny : דרום חילופי اقرأ التعليمات قبل الاستخدام. használat előtt olvassuk el az utasítást : Pred uporabo preberite ustrezna navodila Прочетете указанията за употреба : Enne kasutamist lugege instruksiooni Prieš naudojimą perskaityti instrukciją izlasīt instrukcijas pirms lietošanas Prije uporabe pročítajte upute:</p>	X
---	--	---	---

	<p>Danger : Danger : Gefahr : Peligro : Pericolo : Perigo : Gevaar : ΚΙΝΔΥΝΟΣ: Niebezpieczeństwo : Vaara : Fara : Fare : Pericol :</p>	<p>Опасно : Tehlike : Nebezpečí : Nebezpečnost : סכנה. خطر. Veszély : Nevarnost: Опасност : Oht Pavojus Bistamība opasnost :</p>	X
---	--	--	---



	Poids :	Bec :	0,7 kg
	Weight :	Agirlik :	
	Gewicht :	Hmotnost :	
	Peso :	Hmotnosť :	
	Peso :	משקל	
	Peso :	الوزن.	
	Gewicht :	Súly :	
	ΒΑΡΟΣ :	Teža :	
	Masa :	Терно :	
	Paino :	Raskus	
	Vikt :	Svoris	
	Vægt :	Svars	
	Greutate :	Težina :	

	Soumis à recyclage	Не выбрасывайте в мусорный ящик	X
	Subjected to recycling	Atmayiniz :	
	Sujeto a reciclaje	Nevyhazujte je do běžného odpadu :	
	Sottoposti a riciclaggio	Neodhadzovat :	
	Sujeitos à reciclagem	אין לזרוק סוללות	
	Não deite no lixo :	فلا ترمدها هكذا في القمامة.	
	Niet wegwerpen :	ne mečite!	
	ΜΗΝ ΤΗΝ ΠΙΤΕΤΕ :	Ne odvržite ga/jih vstran :	
	Nie wyrzucac :	Не го изхвърляйте :	
	Älä heitä pois luontoon :	Ärge visake seda minema :	
	Batteriet får inte kastas :	Nemětykíte :	
	Bortkast det ikke:	Nemest :	
	Nu le auncati :	Podliježe recikliranju	

FR-Recyclage des déchets:

Les outils, accessoires et leur emballages doivent suivre une voie de recyclage adaptée. Conformément aux directives Européenne 2002/96/CE et 91/157/CEE, les composants d'un produit doivent être séparés, collectés, recyclés ou éliminés en conformité avec les réglementations environnementales en vigueur. Les appareils, batteries, piles, huiles, emballages devront être déposés dans les systèmes d'élimination des déchets spéciaux tels que déchetteries. Renseignez vous auprès de votre commune pour connaître l'organisme le plus proche à même de retraiter ou de collecter ces déchets.

EN-Waste recycling:

The tools, accessories and their packaging must use an appropriate recycling channel. In compliance with European Directives 2002/96/EC and 91/157/EEC, a product's components must be separated, collected, recycled or eliminated in accordance with the environmental regulations in force. The appliance, batteries, oils and packaging must be deposited in the special waste elimination systems such as the waste collection centres. Ask your commune for information on the nearest organisation in a position to reprocess or collect this waste

ES-Reciclado de los residuos:

Las herramientas, los accesorios y los envases tienen que seguir la vía de reciclaje adecuada. En virtud de las directivas europeas 2002/96/CE y 91/157/CEE, los componentes de un producto deben separarse, recogerse, reciclarse o eliminarse de acuerdo con las reglamentaciones medioambientales vigentes. Los aparatos, baterías, pilas, aceites, envases deberán llevarse a los centros de eliminación de residuos especiales tales como los ecoparques. Pedir información al municipio para conocer el centro más cercano apto para reciclar o recoger dichos residuos.

IT-Riciclaggio dei rifiuti:

Gli apparecchi, i loro accessori ed imballaggi devono essere sottoposti ad un processo di riciclaggio appropriato. In conformità con le direttive europee 2002/96/CE e 91/157/CEE, i componenti di un prodotto devono essere separati, raccolti, riciclati o smaltiti in conformità con le normative ambientali in vigore. Gli apparecchi, le batterie, le pile, gli oli, gli imballaggi dovranno essere conferiti nei sistemi di smaltimento dei rifiuti speciali come le isole ecologiche. Informarsi presso il proprio comune per sapere qual è l'ente più vicino in grado di fare il trattamento o la raccolta differenziata di questi rifiuti

PT-Reciclagem do lixo:

As ferramentas, acessórios e suas embalagens devem seguir um canal de reciclagem adaptado. Confrontemente às diretivas europeias 2002/96/CE e 91/157/CEE, os componentes de um produto devem ser separados, recolhidos, reciclados ou eliminados de acordo com as regulamentações ambientais em vigor. Os aparelhos, baterias, pilhas, óleos e embalagens deverão ser depositados nos sistemas de eliminação de detritos especiais, tais como unidades de triagem de detritos. Informar-se junto ao seu concelho municipal para conhecer o órgão mais próximo habilitado a evacuar ou recolher estes detritos.





	<p>Porter des lunettes de sécurité : Wear protective eyewear : Schutzbrille tragen : Llevar puestas gafas protectoras : Portare de gli occhiali di sicurezza : Utilizar óculos de segurança : Draag een veiligheidsbril : ΦΟΡΑΤΕ ΓΥΑΛΙΑ ΑΣΦΑΛΕΙΑΣ: Zakładać okulary ochronne : Käytä suojalaseja : Använd skyddsglasögon : Der skal benyttes sikkerhedsbriller : Purtati ochelari de protectie :</p>	<p>Наденьте защитные очки : Güvenlik gözlükleri takın : Používejte bezpečnostní brýle : Noste ochranné okuliare : תחבו יפקשמ ביכרהל אנ حمل نظارات وقائية. Viseljen védőszemüveget : Nositi zaščitna očala : Да се използват защитни очила : Kandke kaitseprille Nešioti apsauginius akinius Valkät aizsargbrilles Nosite zaštitne naočale:</p>	<p>X</p>
---	--	--	----------

	<p>Porter un masque anti-poussière: Wear a dust mask : Staubschutzmaske tragen : Llevar puesta una careta de protección contra el polvo : Indossare una mascherina anti-polvere : Utilizar uma máscara anti-poeira : Draag een stofmasker : ΧΡΗΣΗ ΠΡΟΣΤΑΤΕΥΤΙΚΗ ΜΑΣΚΑ : Zakładać maskę przeciwpylową Käytä pölysuojust : Bär mask mot damm : Der skal benyttes beskyttelsesmaske mod støv: Purtati mască anti-praf :</p>	<p>Наденьте респиратор : Toza karşı maske takın : Používejte masku proti prachu : Noste ochrannú masku proti prachu : קבא דגג הכבס שובחל אנ لبس قناع خضاض للغبارة. Viseljen porvédó maszkot Nositi zaščitno masko proti prahu: Да се използва защитна маска : Kandke tolmmaski. Dėvėti respiratorių Valkät aizsarg masku pret putekljem Nosite masku za prašinu</p>	<p>X</p>
---	--	---	----------

	<p>Porter une protection auditive: Wear hearing protective equipment: Gehörschutz tragen: Llevar puesta una protección auditiva: Portare una protezione uditiva: Utilizar uma protecção auditiva: Draag gehoorbeschermers: ΦΟΡΑΤΕ ΠΡΟΣΤΑΣΙΑ ΑΚΟΗΣ: Zakładać słuchawki ochronne Käytä kuulosuojaimia: Bär hörselskydd: Der skal benyttes høreværn: Purtati căști de protecție auz:</p>	<p>наденьте средства звуковой защиты: İşitsel koruma aleti takın: Používejte ochranu sluchu: Noste ochranné slúchadlá: יש ל הרכיב הגנת שמיעה لبس خوذة خضاض الخضجيج. Viseljen fülvédőt Nositi zašito ušes: Да се използва слухови защитни средства: Kandke kõrvakaitset Nešioti apsaugą nuo triukšmo valkät dzirdes aizsarglīdzekli Nosite zaštitu za sluh:</p>	<p>X</p>
---	---	--	----------

	<p>Porter des gants : Use rubber gloves : Schutzhandschuhe tragen : Llevar guantes de protección : Indossare i guanti di protezione : Utilizar luvas de protecção : Draag veiligheidshandschoenen : ΧΡΗΣΗ ΠΡΟΣΤΑΤΕΥΤΙΚΩΝ ΓΑΝΤΙΩΝ : Używać rękawic ochronnych : Käytä suojakäsineitä : Använd skyddshandskar : Der skal benyttes handsker : Purtati mănuși :</p>	<p>Наденьте перчатки : Eldiven takın : Noste rukavice : Noste rukavice : תופבב שובכל אנ لبس قفازات. Viseljen kesztyű t Nositi rokavice: а се използва предпазни ръкавици : Kandke kindaid Mūvēti pirštines Valkät cimds Nošenje rukavica:</p>	<p>X</p>
---	---	---	----------





Niveau de puissance acoustique : Acoustic power level : Schalleistungspegel : Nivel de potencia acústica : Livello di potenza acustica: Nivel de potência acústica: Niveau akoestisch vermogen : ΕΠΙΠΕΔΟ ΙΣΧΥΟΣ ΗΧΟΥ: Poziom mocy akustycznej : Käytä suojalaseja : Ljudstyrkenivå : Lydstyrke : Nivel putere acustică :	уровень мощности звука : Akustik basınç seviyesi : Hladina zvukového výkonu: Hladina zvukového výkonu: רמת כוח אקוסטי. מסתوى الضجيج. a hangnyomás szintje : Nivo akustične jakosti : Равнище на вибрации : Helivõimsuse nivoo Triukšmo lygis Akustiskās jaudas līmenis Razina zvučne snage:	83,5 dB (A)
--	---	--------------------

Niveau de pression acoustique : Acoustic pressure level : Schalldruckpegel : Nivel de presión acústica : Livello di pressione acustica : Nivel de pressão acústica : Niveau akoestische druk : ΣΤΑΘΜΗ ΗΧΗΤΙΚΗΣ ΠΙΕΣΗΣ: Poziom mocy akustycznej : Käytä kuulosuojaimia: Ljudtrycksnivå : Lydtryk : Nivel presiune acustică :	Уровень акустического давления. : Akustik basınç seviyesi : Hladina akustického tlaku : Hladina akustického tlaku : רמת לחץ אקוסטי. מסתوى الضغط المرصومي. A hangnyomás szintje : Nivo akustičnega pritiska: Равнище на акустично налягане : Helirõhu nivoo Akustinio spaudimo lygis Akustiskā spiediena līmenis Razina zvučnog tlaka:	72,5 dB (A)
---	--	--------------------

NIVEAU SONORE D'EMISSION:

A VIDE

Pression acoustique LpA poste opérateur
 Incertitude

72,5 dB
 3

Puissance acoustique LWA
 Incertitude

83,5 dB
 3

Valeurs déterminées suivant le code d'essai de l'annexe B de la norme EN 61029-1 avec emploi des normes de base ISO 11201 et ISO 3744.

Les niveaux de pression acoustique obtenus in situ dépendent:

- Des niveaux réels de la machine considérées, en prenant en compte les incertitudes déclarées;
- Du local et de l'installation de la machine. Préférez une pièce dont l'acoustique est plus feutrée. Evitez les pièces vide à grande résonance. Placez vous auprès d'une fenêtre le cas échéant.
- Des outils montés, des pièces travaillées, des réglages choisis,...

Niveau de vibration : Hand/arm vibration level : Vibrationspegel Hand/Arm : Nivel de vibración mano/brazo : Livello di vibrazione mano/braccio : Nivel de vibração mão/braço : Trillingsniveau hand/arm : ΕΠΙΠΕΔΟ ΚΡΑΔΑΣΜΩΝ: Poziom wibracji rózka/ramióz : Tärinätaso: Vibrationsnivå hand/arm : Vibrationsniveau : Nivel vibrații :	Уровень вибрации : Titreşim seviyesi : Úroveň vibrací : Hladina vibrácií : רמת תנודות מסתوى الارتجاج. Vibrációs szint : Nivo vibracij : Равнище : Vibrācijas līmenis. Vibrācijas lygis Vibratsiooninivo Razina vibracija:	3,74 m / s²
--	---	-------------------------------

VIBRATIONS:

Total des valeurs de vibration (somme vectorielle des trois directions) déterminée selon EN 60745:

a 3,74 m/s²
 Incertitude K_{cw} 1,5 m/s²

L'amplitude d'oscillation peut être utilisée comme valeur de comparaison d'outils électroportatifs.

Attention: Si l'outil électroportatif est utilisé pour d'autres applications, avec d'autres outils de travail, l'amplitude d'oscillation peut être différente.





DCP 170

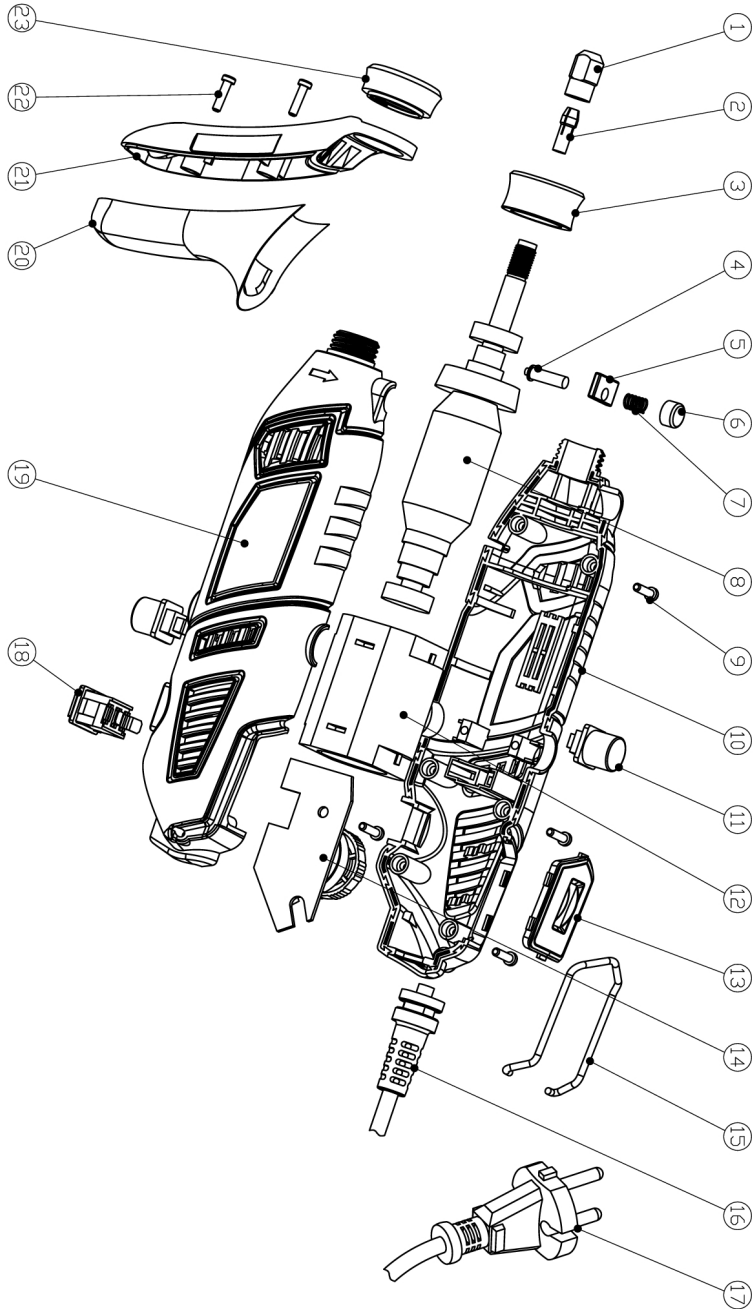

DECLARATION DE CONFORMITE
DECLARATION OF CONFORMITY
KONFORMITÄTSEKLRÄRUNG
DECLARACIÓN DE CONFORMIDAD
DICHIARAZIONE DI CONFORMITÀ
DECLARAÇÃO DE CONFORMIDADE
CONFORMITEITSVERKLARING
ΔΗΛΩΣΗ ΣΥΜΜΟΡΦΩΣΗΣ
DEKLARACJA ZGODNOŚCI
VAATIMUSTENMUKAISUUSILMOITUS
FÖRKLARING OM ÖVERENSSTÄMMELSE
ДЕКЛАРАЦИЯ ЗА СЪОТВЕТСТВИЕ
ÖVERENSSTÄMMELSESEKLRÆRING

DECLARATIE DE CONFORMITATE
ДЕКЛАРАЦИЯ СООТВЕТСТВИЯ
UYGUNLUK BEYANI
PROHLÁŠENÍ O SHODĚ
VYHLÁŠENIE O ZHODE
המאתה תרצה
التصديق بالمطابقة
MEGFELELŐSÉGI NYILATKOZAT
IZJAVA O SKLADNOSTI
VASTAVUSDEKLARATSIOON
ATBILSTĪBAS DEKLARĀCIJA
ATITIKTIES DEKLARACIJA
IZJAVA O SUKLADNOSTI

Le soussigné,
The undersigned,
Die Unterzeichnenden,
El suscrito,
Il sottoscritto,
O abaixo assinado,
De ondergetekende,
Ο ΚΑΤΩΘΙ ΥΠΟΓΡΑΦΜΕΝΟΣ,
Nizej podpisany,
Allékirjoittanut,
Den underteignede,
долуподписаният,
Undertegnede,

Declare par la présente que,
Hereby declares that,
erklärt hiermit,
Por la presente declara que,
Con la presente dichiara che,
Declara que,
verklaart hierbij dat,
ΔΙΑ ΤΟΥ ΠΑΡΟΝΤΟΣ ΔΗΛΩΝΕΙ ΟΤΙ,
Niniejszym oświadczam, że:
Täten julistaa, että
förklarar härmed att,
С настоящото декларира, че
Erklærer hermed, at

Personne autorisée à constituer
le dossier technique :
Ronan GUILLIOT



FAR GROUP EUROPE
192, Avenue Yves Farge
37700 St. Pierre-des-Corps
FRANCE

Subsemnatul,
Нижеподписавшиися,
Asağida imzaşya olan,
Podpisany,
Podpisany,
الذم مؤتمه
أناذنا نؤ قؤدملا,
Alulifrott,
Podpisani,
Allakirjoittanu,
Apakša parakštijies,
Tolliau pasirašes,
Nize potpisani,

Prin prezenta declară că,
Настоящим заявляет, что,
Burada beyan eder ki,
Tímto prohlašuje, že
Tymto vyhlasuje, že
כך תאזב ריהצמ
أذہ ب جوبہ نل عت
Ezennél kijelenti, hogy
s tem izjavlja, da
Käesolevaga teatab, et
Ar šo paziņo, ka
Šiuo pareiškia, kad
Ovime izjavljuje da,

Mini meuleuse / Mini grinder / Mini-Schleifmaschine / Mini esmeriladora / Mini molatrice / Mini esmerilador / Kleine slijpmachine / ΜΙΝΙ ΜΥΛΟΣ /
Mini szifrierka / Pienošiomaikone / Miniatyrslipmaskin / **МИНИ ТОЧИЛО / Mini slibemaskine / Minipolizor / МИНИ-ШИЛФОВАЛЬНЫЙ СТАНОК / mini őgütűcő /**
kufriková mini bruska / kufriková mini bruska / **החשמל ינימ / قري عوص ؤخالج / Mini koszörűgép / Mini bruslini / Väikejalvatusmasin kohvris /**
Mini slijpmašina somä / mäza mälmo masinële / Mini brusilica

code

FARTOOLS / 115426 / DCP 170 / DM-170B

Est conforme et satisfait aux directives et normes CE,
Complies with and satisfies CE directives and standards,
Entspricht und erfüllt die CE-Richtlinien und -Normen,
Cumple y satisfice las directivas y normas CE,
Conforme e soddisfa le direttive e gli standard CE,
Cumpre e satisfaz as directivas e padrões CE,
Voldoet aan en voldoet aan de CE-richtlijnen en normen,
ΣΥΜΜΟΡΦΩΝΕΤΑΙ ΚΑΙ ΙΚΑΝΟΠΟΙΕΙ ΤΙΣ ΟΔΗΓΙΕΣ ΚΑΙ ΤΑ ΠΡΟΤΥΠΑ CE,
Spełnia i spełnia dyrektywy i normy CE,
Täyttää ja täyttää CE-direktiivit ja -standardit,
Överensstämmer med och uppfyller CE-direktiv och standarder,
Съответства и отговаря на CE директивите и стандартите,
Overholder og opfylder CE-direktiver og standarder,

Respectă și îndeplinește directivele și standardele CE,
Соответствует и удовлетворяет директивам и стандартам CE,
CE direktiflerine ve standartlarına uygun ve tatmin edici,
Vyhovuje a splňuje směrnice a normy CE,
Vyhovuje a splňa smernice a normy CE,
Ykqro tuiqnab dmoqo CE,
اهي بلقو CE ري اي عوب تاهي عوت عم قفاوتى
Megfelel és megfelel a CE irányelveknek és szabványoknak,
Ustrezja in izpolnjuje CE direktive in standarde,
Vastab ja vastab CE direktiividele ja standarditele,
Atbilst un atbilst CE direktivām un standartiem,
Atitinka ir atitinka CE direktivas ir standartus,
Udovljava i zadovoljava CE direktive i standarde,

2006/42/EC, 2014/30/EU, 2015/863/EU, 2011/65/UE

EN60745-1 :2009+A11:2010
EN60745-2-23:2013
EN55014-1 :2021
EN55014-2 :2021
ENIEC61000-3-2 :2019/A1:2021
ENIEC61000-3-3 :2013+A1:2019

Ronan GUILLIOT,
Directeur général
27/12/2021
Fait à St. Pierre-des-Corps



Plaques signalétiques - naamplaatjes - placas de identificación - placas de identificação - targhette - machine labels

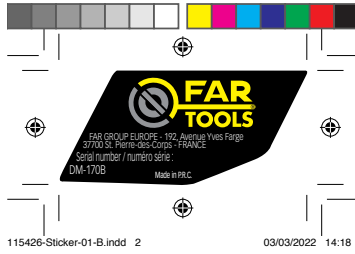
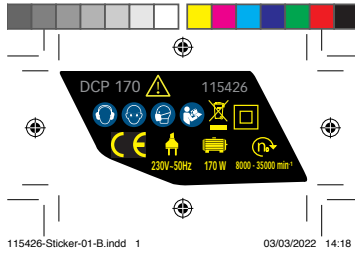



FR. GARANTIE

Cet outil est garanti contractuellement contre tout vice de construction et de matière, à compter de la date de vente à l'utilisateur et sur simple présentation du ticket de caisse. La garantie consiste à remplacer les parties défectueuses. Cette garantie n'est pas applicable en cas d'exploitation non conforme aux normes de l'appareil, ni en cas de dommages causés par des interventions non autorisées ou par négligence de la part de l'acheteur. La garantie ne s'applique pas sur les dommages causés par une défaillance de l'outil.

DE. GARANTIE

Die Garantiezeit für dieses Gerät in Bezug auf Konstruktions- und Materialfehler beträgt lt. Vertrag bei Vorlage des Kassensbons. Die Garantieleistung besteht im Ersatz schadhafter Teile. Die Garantie erlischt bei einem Einsatz des Geräts, der nicht normentsprechend ist, bei Schäden, die auf unsachgemäße Eingriffe zurückzuführen sind bzw. bei Nachlässigkeit seitens des Käufers. Die Garantie erstreckt sich nicht auf Schäden, die auf Fehlfunktionen des Geräts zurückzuführen sind.

IT. GARANZIA

Quest' attrezzo è garantito per contratto contro qualsiasi difetto di costruzione e di materia, a partire dalla data di vendita all' utente e su semplice presentazione dello scontrino. La garanzia consiste nel sostituire le parti difettose. Questa garanzia non è applicabile in caso di sfruttamento non conforme alle norme dell' apparecchio, né in caso di danni causati da interventi non autorizzati o da negligenza da parte dell' acquirente. La garanzia non si applica ai danni causati da un' avaria dell' attrezzo.

EN. GARANTIE

This tool is guaranteed, in writing, against any defect in manufacture of parts from the date of sale, upon simple presentation of the sales slip. The guarantee is limited to the replacement of faulty parts. This guarantee is not applicable in the event of usage which is not conform with the intended usage of the apparatus, nor in the event of damage caused by unauthorised servicing or negligence on behalf of the purchaser. This guarantee does not apply to any damage caused by

the failure of this tool.

ES. GARANTIA

Esta herramienta se garantiza contractualmente contra todo defecto de construcción y materia, a partir de la fecha de venta a l' usuario y sobre simple presentación del recibo de caja. La garantía consiste en sustituir a las partes defectuosas. Esta garantía no es aplicable en caso de explotación no conforme a las normas del aparato, ni en caso de daños causados por intervenciones no autorizadas o por negligencia por parte del comprador. La garantía no se aplica sobre los daños causados por un fallo del herramienta.

NL. GARANTIE

Dit gereedschap heeft een garantie tegen constructiefouten en materiaaldefecten, die geldig is vanaf de aankoopdatum door de gebruiker, op vertoning van de kassabon. De garantie betreft de vervanging van de defecte onderdelen. Deze garantie is niet van toepassing indien het apparaat niet volgens de normen gebruikt is, noch in geval van schade veroorzaakt door oneigenlijk gebruik of nalatigheid van de koper. De garantie is niet van toepassing op schade voortvloeiend uit een defect van het gereedschap.

PT. GARANTIA

Esta ferramenta tem uma garantia contratual contra qualquer defeito de construção e de material, a partir da data de venda ao utilizador e sobre simples apresentação do talão da caixa. A garantia consiste em substituir as partes defeituosas. Esta garantia não é aplicável no caso de exploração não conforme às normas do aparelho, nem em caso de danos causados pelas intervenções não autorizadas ou por negligência da parte do comprador. A garantia não se aplica para os danos causados por uma falha da ferramenta.

EL. ΕΓΓΥΗΣΗ

ΑΥΤΟ ΤΟ ΕΡΓΑΛΕΙΟ ΕΙΝΑΙ ΣΥΜΒΑΤΙΚΑ ΕΓΓΥΗΜΕΝΟ ΓΙΑ ΟΠΟΙΟΔΗΠΟΤΕ ΚΑΤΑΣΚΕΥΑΣΤΙΚΟ ΚΑΙ ΥΛΙΚΟ ΕΛΑΤΤΩΜΑ, ΑΠΟ ΤΗΝ ΗΜΕΡΟΜΗΝΙΑ ΠΩΛΗΣΗΣ ΣΤΟΝ ΧΡΗΣΤΗ ΚΑΙ ΜΕ ΤΗΝ ΕΠΙΔΕΙΞΗ ΤΗΣ ΑΠΟΔΕΙΞΗΣ ΠΩΛΗΣΗΣ. Η ΕΓΓΥΗΣΗ ΣΥΝΙΣΤΑΤΑΙ ΣΤΗΝ ΑΝΤΙΚΑΤΑΣΤΑΣΗ ΤΩΝ ΕΛΑΤΤΩΜΑΤΙΚΩΝ ΕΞΑΡΤΗΜΑΤΩΝ. ΑΥΤΗ Η ΕΓΓΥΗΣΗ ΔΕΝ ΙΣΧΥΕΙ ΣΕ ΠΕΡΙΠΤΩΣΗ ΛΕΙΤΟΥΡΓΙΑΣ ΠΟΥ ΔΕΝ ΣΥΜΜΟΡΦΩΝΕΤΑΙ ΜΕ ΤΑ ΠΡΟΤΥΠΑ ΤΗΣ ΣΥΣΚΕΥΗΣ, ΟΥΤΕ ΣΕ ΠΕΡΙΠΤΩΣΗ ΖΗΜΙΑΣ ΠΟΥ ΠΡΟΚΑΛΕΙΤΑΙ ΑΠΟ ΜΗ ΕΞΟΥΣΙΟΔΟΤΗΜΕΝΕΣ ΕΠΕΜΒΑΣΕΙΣ Η ΑΜΕΛΕΙΑ ΕΚ ΜΕΡΟΥΣ ΤΟΥ ΑΓΟΡΑΣΤΗ. Η ΕΓΓΥΗΣΗ ΔΕΝ ΙΣΧΥΕΙ ΓΙΑ ΖΗΜΙΕΣ ΠΟΥ ΠΡΟΚΑΛΟΥΝΤΑΙ ΑΠΟ ΑΣΤΟΧΙΑ ΕΡΓΑΛΕΙΟΥ.

PL. GWARANCJA

Narz dzie jest obj te gwarancja

na wszelkie wady konstrukcyjne i materiałowe, licząc od daty sprzedaży u użytkownika i po okazaniu paragonu kasowego. Gwarancja obejmuje wymianę cz. Aci wybrakowanych. Gwarancja nie znajduje zastosowania w przypadku u użytkownika niezgodnego z normami urządzenia, ani w przypadku szkód spowodowanych działaniami niedozwolonymi lub zaniedbaniami ze strony nabywcy. Gwarancja nie obejmuje szkód powstałych z powodu upadku urządzenia.

SV. GARANTI

Detta verktyg har en avtalsenlig garanti mot konstruktions och materialfel, från och med tidpunkten för användarens inköp och genom uppvisning av kassakvittot. Garantin består i att ersätta de bristfälliga delarna. Denna garanti gäller inte om användningen inte motsvarar apparatens standarder, inte heller vid skador som orsakas av ej tillätna ingrepp eller på grund av köparens vårdslöshet. Garantin gäller inte förskador som orsakats av att verktyget fungerat bristfälligt.

FI. TAKUU

Tämän laitteen takuu on voimassa sopimusmenumukaisesti kattaen kaikki rakenne- ja materiaali- ja lukien ostopäivästä kassakuittia vastaan. Takuu sisältää viallisten osien korvaamisen. Takuu ei korvaa ohjeiden vastaista käyttöä eikä valtuuttamattomien henkilöiden kassittelyä tai ostajan huolimattomuudesta aiheutuneita vahinkoja. Takuu ei vastaa myöskään toimintahäiriöistä aiheutuneita vahinkoja.

BU. Гаранция

Този инструмент е под договорна гаранция срещу всякакъв дефект в изработката и използваните материали, считано от датата на продажба на потребителя и само срещу представяне на касовата бележка. Гаранционното обслужване се състои в замяна на дефектните части. Настоящата гаранция не е валидна когато апаратът се използва по начин, несъответстващ на стандарта за работа с него, както и в случай на щети, нанесени от неоторизирани лица, или вследствие на проявена небрежност от страна потребителя. Гаранцията не покрива щети, произтекли вследствие на техническа неизправност на апарата.

DA. GARANTI

Dette værktøj er dækket af en garantikontrakt for konstruktions- og materialefej, som gælder fra købsdatoen ved visning af kassabonen. Garantien består i at udskifte de defekte dele. Garantien dækker ikke fejl opstået som følge af anvendelse, som ikke overholder

SERVICE APRÈS VENTE - AFTER SALE SERVICE

FARGROUP EUROPE - 192, Avenue Yves Farge - 37700 St. Pierre-des-Corps - FRANCE

fargroup@fargroup.net

GARANTIE - WARRANTY



standarderne for apparatet, eller skader opstået ved ikke autoriserede indgreb eller sløshed fra brugerens side. Garantien dækker ikke skader opstået, fordi værktøjet har svigtet.

RO. GARANTIE

Acest aparat este garantat din punct de vedere contractual împotriva tuturor vicilor de construcție și de material, începând de la data vânzării lui către utilizator și la simpla prezentare a bonului de casa. Garanția constă în înlocuirea componentelor defecte. Această garanție nu se aplică în cazul exploatarei în alt mod decât cel recomandat de normele aparatului și nici în caz de stricăciuni provocate de intervenții neautorizate sau prin neglijența cumpărătorului. Garanția nu se aplică asupra pagbelor cauzate de o defectare a aparatului.

RU. ГАРАНТИЯ

Данное изделие обладает силой контракта гарантии, покрывающей все возможные дефекты изготовления и материала. Гарантия вступает в силу с даты продажи изделия пользователю, для этого достаточно сохранить и предъявить полученный в кассе чек. Гарантия обязывает изготовителя заменить дефектные части изделия. В случае не соответствующего нормам использования демонтажа или ремонта или небрежного обращения действие гарантии прекращается. Гарантия не покрывает ущерба, возникшего в результате сбоев в работе изделия.

TU. GARANTI

Bu arac, satis tarihinden itibaren, kullanıcının sağdece vezne alindisini sunmasiya tum uretim ve malzeme hatasina karsi garantilidir. Garanti eksik olan kisimlari degistirmek icindir. Bu garanti aracin sartlarina uygun olmayan isleme durumunda, izin verilmeyen kullanimlardan kaynaklanan, hasarlarda veya alicinin istegi durumunda uygulanmaz. Garanti malzemenin bir eksikliginden meydana gelen bir zararda uygulanmaz.

CS. ZÁRUKA

Pro tento nástroj platí smluvní záruka na všechny výrobní a materiálové vady od data prodeje uživateli a na základě předložení pokladního bloku. Záruka spočívá ve výměně vadných částí. Tato záruka neplatí

v případě použití přístroje, které neodpovídá normám, ani v případě škod způsobených nepovolenými zásahy nebo nedbalostí ze strany kupujícího. Záruka se nevztahuje na škody způsobené závadou nástroje.

SK. ZÁRUKA

Pre tento nástroj platí zmluvná záruka na všetky výrobné a materiálové chyby od dátumu predaja užívateľovi a na základe predloženia pokladničného bloku. Záruka spočíva vo výmene chybných častí. Táto záruka neplatí v prípade použitia prístroja, ktoré nezodpovedá normám, ani v prípade škod spôsobených nepovolenými zásahmi alebo nedbalosťou zo strany kupujúceho. Záruka sa nevztahuje na škody spôsobené poruchou nástroja.

HE. תְּחִיבָה

ימגב לכל תיחוב תיחוב הסוכמ הז לכ שמתשל הרכימה מימ ומוחוה רוצייה תללכ תיחובה. הפוקה שגך תנקהב הניא הז תיחובה. סימוגה סיכלה תפלקה סינקת דמוע וניאש דויב שומיש לע להח יתלב תברעתהמ האצותכ סרגנש קזנ לו וא הנוקה דצמ תונלשר וא תישרומ לשצמ האצותכ סרגנש קזנ הסכמ הניא לכב

AR. الضمان

على مجرد توديم نطاق الشراء يتغل في تاريخ البيع الى المستهلك وبيناء عيب فني التصدي عوفي الجواند اعترابا ان هذه الاع دة مضمونة شعاقديا من ان الاجزاء، ولا فسيح الة تعرضه لتلفات حالة الاستخدام غير المطابق لمعايير لا يكون هذا الضمان قابلا للتطبيق فني علل الضمان فسي سببدال الاجزاء الاعطلة لا ينطبق الضمان على الخرد الزاتج عن مخرجة او فسي حالة الاملال من قبل المشتري باحثة عن عمليات تدخل عوي

HU. GARANCIA

Erre a szerszámra szerződéses garanciát vállalunk bármilyen gyártási és anyaghibá felmerülése esetére a fogvaszto részere törtent eladás napjától számítva, a penztári blokk egyszerű felmütatása elleneben. A garancia a hibás alkatrészek cserejére terjed ki. Ez a garancia nem érvényes, ha a készüleket nem rendelteszszervez használtak, sem illetéktelen beavatkozások, vagy a vásároló hanyagsága okozta károk esetén. A garancia nem fedezi azokat a károkat, melyeket a szerszám hibás működése okozott.

SL. GARANCIA

To orodje je z garancijsko pogodbo zaščiteno proti vsem napakam v izdelavi in v sestavnem materialu od datuma prodaje naprej in ta velja ob predložitvi blagajniškega računa. Garancija velja za zamenjavo delov z napako. Ta garancija ne velja za uporabo orodja, ki ni v skladu z normami, predpisanimi za omejeno orodje in za primere okvar, ki nastanejo zaradi nedovoljenih posegov

na orodju ali zaradi malomarnega rokovanja kupca. Garancija ne velja za škodo, ki jo lahko povzroci okvara orodja.

ET. GARANTII

See tööriist kuulub lepingu järgi garantiiremonti arvestades alates müumise päevast ja kassatseki alusel kasutatajale koigi konstruktsioonilja materjalivigade puhul. Garantii seisneb defektsete osade välja vahetamises. See garantii ei kehti aparaadi normide ebatavalise eiramise puhul ega ostja poolt keelatud viisil kasutamisest või hooletusseajtmisest tulenevate kahjude korral. Garantii ei kehti seadme defektidest põhjustatud kahjude puhul

LV. GARANTĪJA

Šis prietaisys yra uztikrinamas kaip itin geros kokybes, nuo jo pardavimo datos iki jo panaudojimo. Ir jam yra suteikiama garantinis talonas. Garantijos metu galima pakeisti atsiradusius trumplataikius gedimus. Ši garantija netaikoma esant netinkamam naudojimui ar nesilaikant reikiam šio aparato vartojimo instrukcijai, tai pat pačiame virkelyje ji sugadinus. Garantija taip pat netaikoma, prietaisa naudojant ne pagal paskirti ir ji apgadinus

LT. GARANTUJA

Šim darbarikam ir ligumá noteikta garantija visiem defektiem, kas saistas ar konstrukciju un materialu, sākot ar pardošanas datumu, kad masinu pardoj lietotajam vienkarši uzradot kases ceku. Garantija iekļauj bojoto daļu nomainu. Ši garantija nav derīga, ja aparāts nav lietots saskaņā ar drošības noteikumiem, ne gadījumos ja bojājumi radusies nesānkcionētas lejauksanas gadījumā vai arī pierceja nolaidības del. Garantija nav derīga, ja bojājumi radusies darbarika defekta del

HR. JAMSTVO

Ovaj alat ima ugovorno jamstvo u slucaju bilo kakvih nedostataka u konstrukciji i materijalu, od datuma prodaje korisniku uz jednostavno predocenje racuna. Jamstvo se sastoji u zamjeni neispravnih dijelova. Ovo se jamstvo ne primjenjuje u slucaju uporabe i eksploatacije koja nije sukladna standardima uređaja, niti u slucaju stete uzrokovane neovlastenim intervencijama ili nemarom kupca. Jamstvo se ne primjenjuje na štetu uzrokovanu nekim nedostatkom alata.

SERVICE APRÈS VENTE - AFTER SALE SERVICE

FARGROUP EUROPE - 192, Avenue Yves Farge - 37700 St. Pierre-des-Corps - FRANCE

fargroup@fargroup.net



FAR GROUP EUROPE

Une société du groupe **SIGMA**

192, Avenue Yves Farge
37700 St. Pierre-des-Corps
FRANCE

fartools.com

