

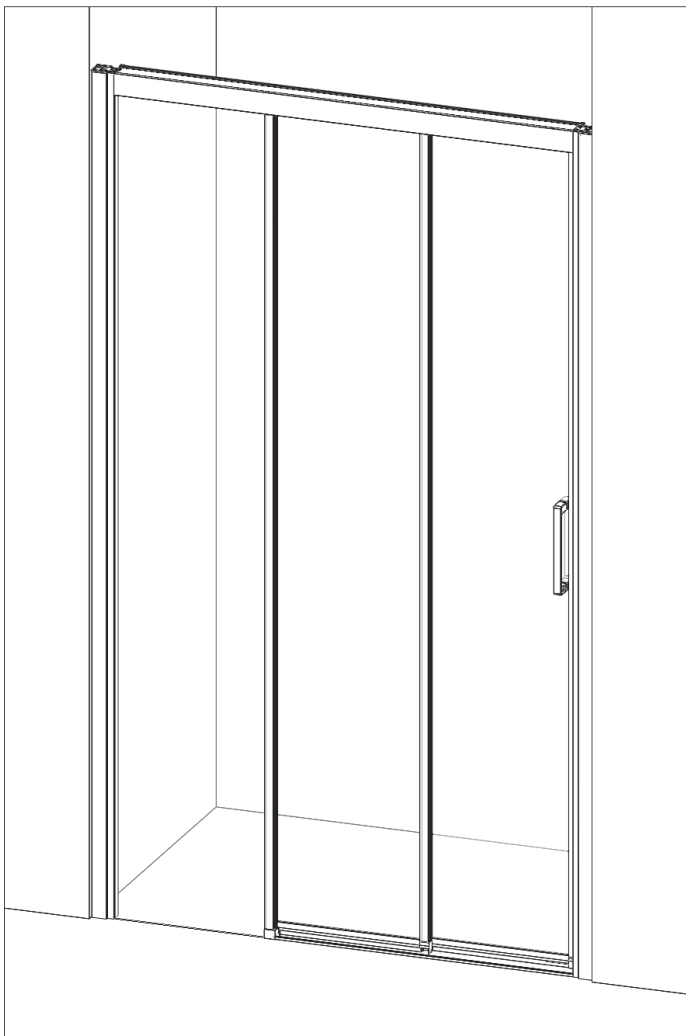

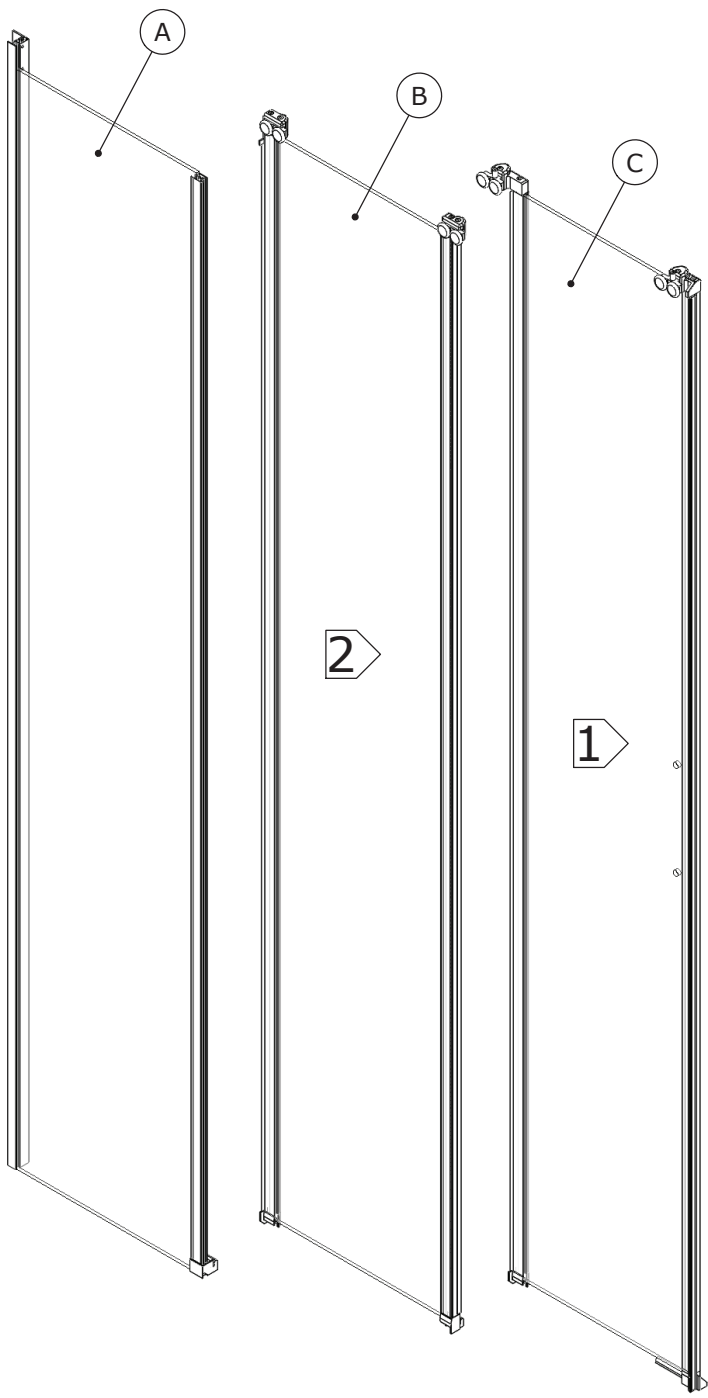

- F Notice de montage ● GB Installation instructions
- E Manual de instalación ● I Istruzioni di montaggio
- NL Montage-instructies ● D Montageanleitung

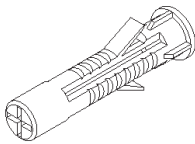
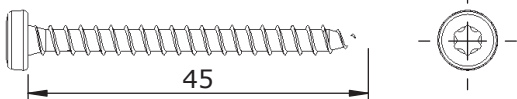
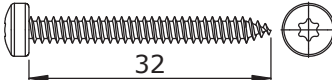
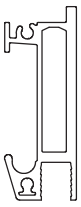
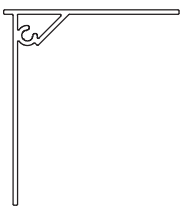
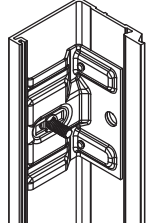
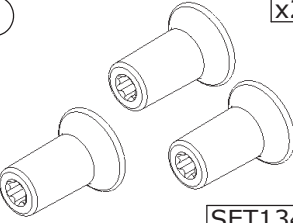

- F Attention aux étapes :
- GB Check installation steps :
- E Atención a los pasos :
- I Attenzione ai passi :
- NL Aandacht voor de stappen :
- D Achtung vor den Schritten :

P. 8 - 12 - 27

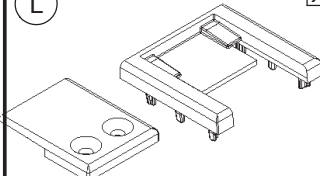

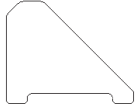
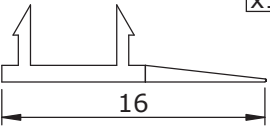
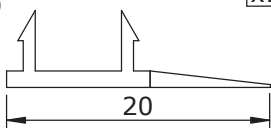
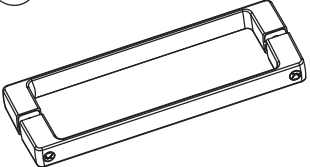
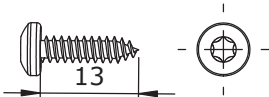
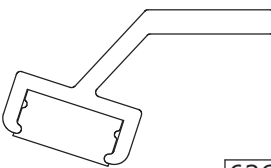
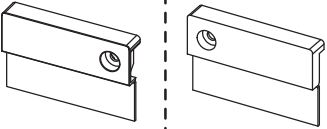
<p>D x6</p>  <p>CHE02</p>	<p>E Ø4 x6</p>  <p>45</p> <p>VIS231</p>		
<p>F Ø3.5 x4</p>  <p>32</p> <p>VIS214</p>	<p>G x1</p>  <p>6332</p>	<p>H x1</p>  <p>6333</p>	
<p>I x2</p>  <p>6268</p>	<p>J x2</p>  <p>SET134</p>	<p>K x2</p>  <p>6270</p>	
<p>L x2</p>  <p>SET137</p>	<p>M Ø3.5 x2</p>  <p>9,50</p> <p>VIS261</p>	<p>N x1</p>  <p>6285</p>	
<p>O x1</p>  <p>16</p> <p>Lg=1922mm JOI304-01 Lg=1938mm JOI304-02</p>	<p>P x1</p>  <p>20</p> <p>Lg=1900mm JOI312-01 Lg=1922mm JOI312-02</p>	<p>Q x1</p>  <p>PGN49</p>	
<p>R Ø3.5 x7</p>  <p>13</p> <p>VIS217</p>	<p>S x1</p>  <p>6264</p>	<p>T x1</p>  <p>PPL1323 PPL1324</p>	

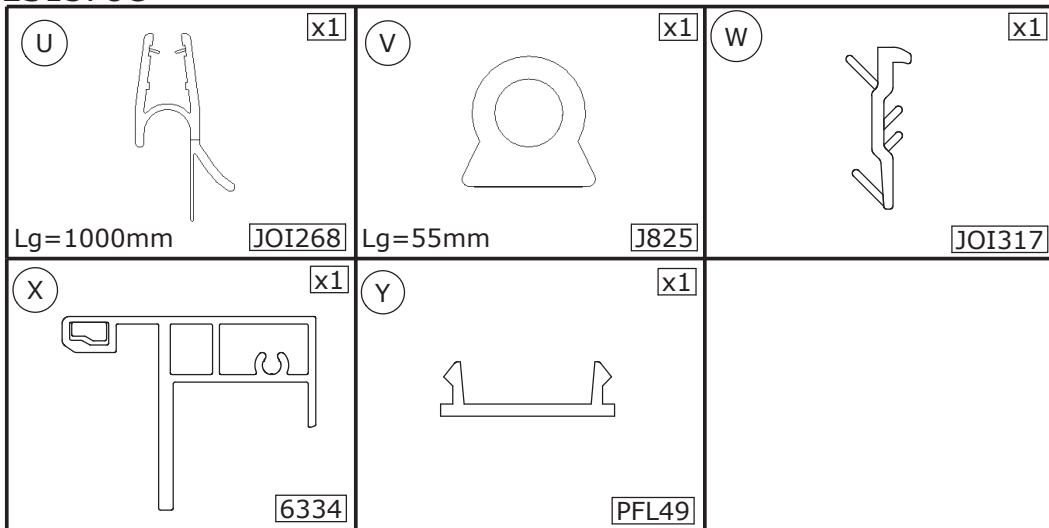

- Les quantités données sont les quantités utiles au montage. les sachets fournis contiennent des pièces supplémentaires.
 - The quantities given are what are required for the installation. There may be some surplus in the package provide.
- Las cantidades indicadas son las cantidades necesarias para el montaje. Las bolsitas incluidas contienen piezas suplementarias.
 - Le quantità fornite sono le quantità necessarie al montaggio. I sacchetti forniti contengono pezzi supplementari.
 - De aangegeven aantallen zijn vereist voor de montage. De verpakking bevat extra onderdelen.
- Die Mengenangaben beziehen sich auf die für die Montage nötigen Teile. Eventuell weitere beige packte Teile ignorieren.

● Outillage nécessaire ● Tools required ● Equipamiento necesario
 ● Attrezzatura necessaria ● Benodigde gereedschap ● Werkzeuge erforderlich

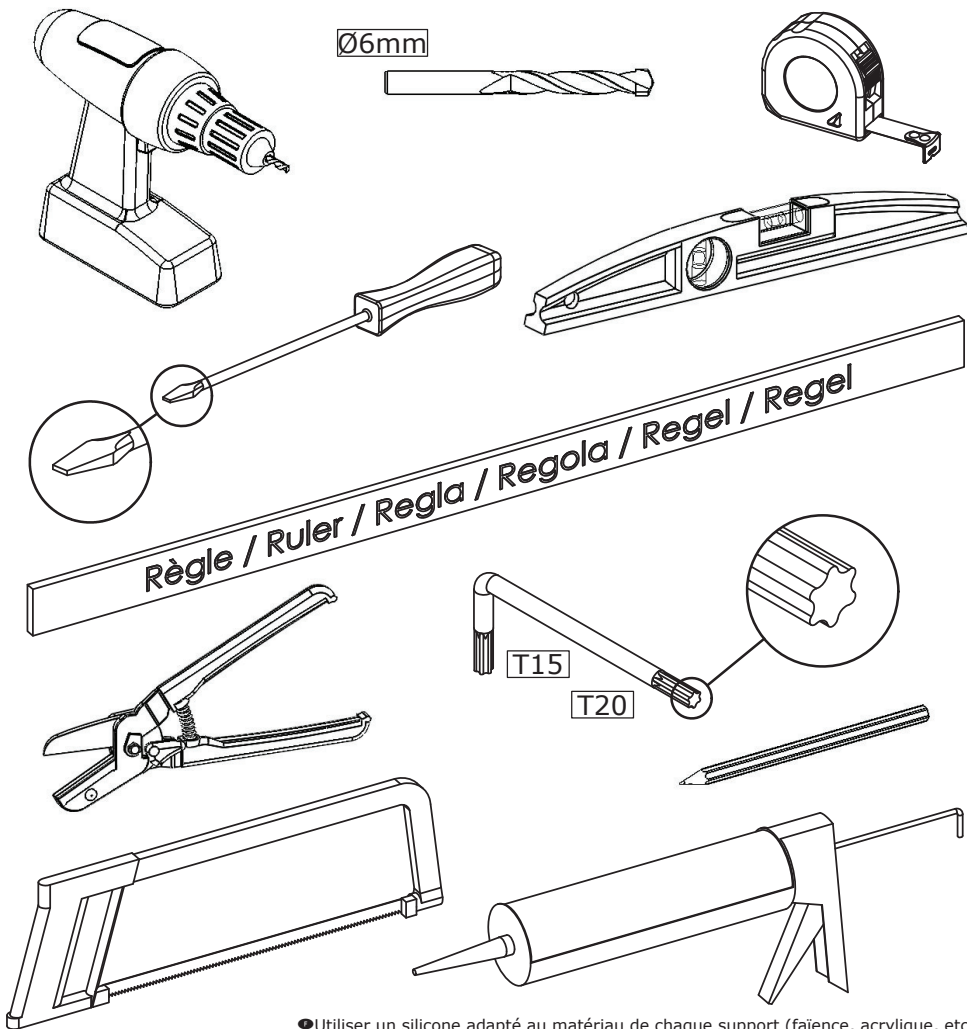

- Utiliser un silicone adapté au matériau de chaque support (faïence, acrylique, etc.)
- Use a silicone sealant that is intended for the surrounding materials (ceramic, acrylic, etc.)
- Usar una silicona adecuada para cada tipo de material (loza, acrílico, etc.)
- Utilizzare un silicone adatto a qualsiasi materiale (ceramica, acrilico, ecc.)
- Gebruik siliconenkit die geschikt is voor iedere ondergrond (tegelwerk, acryl, etc.)
- Für das jeweilige Trägermaterial (Stein, Acryl usw.) geeignetes Silikon verwenden.



● Réversibilité ● Reversibility ● Reversibilidad
 ● Reversibilidad ● Omkeerbaarheid ● Wahlweise Montage

● Montage à gauche
 ● Left hand
 ● Montaje a la izquierda
 ● Montaggio a sinistra
 ● Montage links
 ● Montage links

● Montage à droite
 ● Right hand
 ● Montaje a la derecha
 ● Montaggio a destra
 ● Montage rechts
 ● Montage rechts

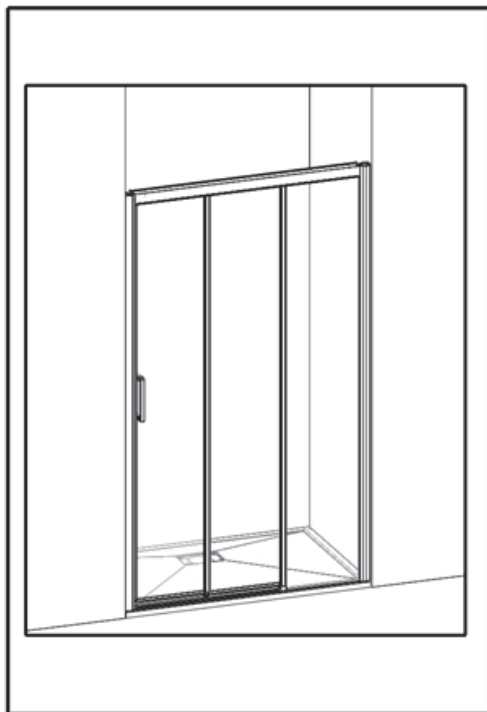
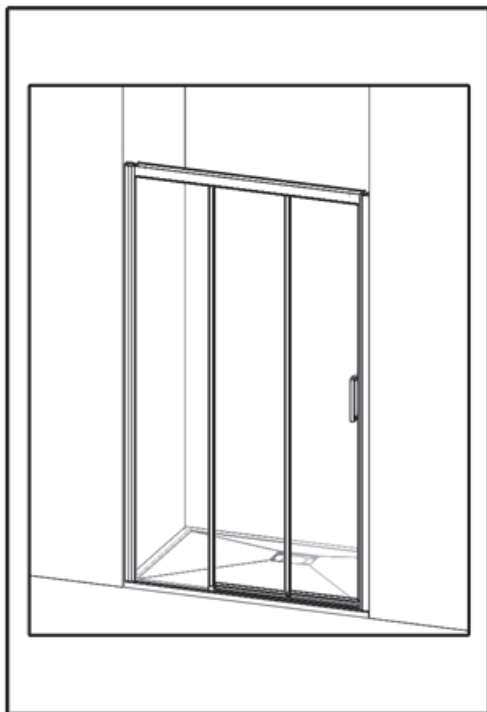

● Vous avez la possibilité de réaliser un montage à droite ou un montage à gauche. Notre notice d'installation décrit un montage à gauche. Si vous voulez réaliser un montage à droite, il vous suffit d'inverser le montage.

● This cubicle can be installed either left or right hand. These installation instructions show a left hand installation.

● Puede realizar un montaje a la derecha o un montaje a la izquierda. Nuestro folleto de instalación describe un montaje a la izquierda. Si desea montar su cabina a la derecha sólo tendrá que realizar el montaje al contrario.

● Avete la possibilità di effettuare il montaggio a destra o a sinistra. Il nostro manuale descrive il montaggio a sinistra. Se volete realizzare il montaggio a destra è sufficiente invertire varie fasi di montaggio.

● U kunt de douchecabine rechts of links monteren. Onze handleiding beschrijft de links montage van de cabine. Keer de montage om als u de cabine rechts wilt monteren.

● Sie haben die Möglichkeit, eine Montage auf der linken Seite oder eine Montage auf der rechten Seite durchzuführen. Unsere Montageanleitung beschreibt eine Montage auf der linken Seite. Wenn Sie die Montage lieber auf der rechten Seite durchführen wollen, müssen Sie nur den Montageprozess umkehren.

- Dans le cas d'une installation en **ANGLE** ● In case of an **ANGLED** installation
- Para una instalación **ÁNGULO** ● In caso di installazione ad **ANGOLO**
- In het geval van een installatie in **ANGLE** ● Im Falle einer Installation in **ANGLE**

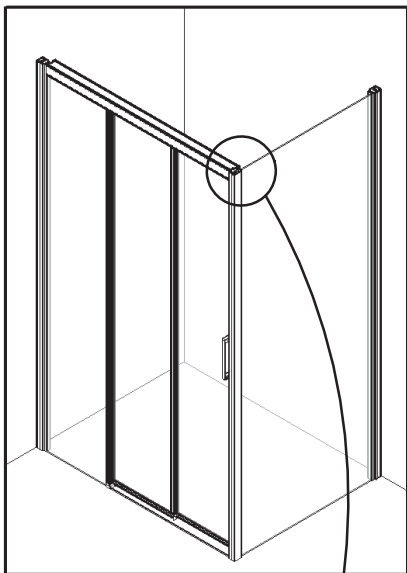

- PFL49 dans colis **PORTE**
- Part PFL49 as supplied with the **DOOR** package
- PFL49 en el bulto **PUERTA**
- PFL49 nel collo della **PORTA**
- PFL49 in **DOOR**-pakket
- PFL49 im **DOOR**-Gehäuse

- PFL49 dans colis **FIXE**
- Part PFL49 as supplied with the **FIXED** package
- PFL49 en el bulto **FIJO**
- PFL49 nel collo della **FISSO**
- PFL49 in **FIXED** pakket
- PFL49 im **FIXED**-Gehäuse

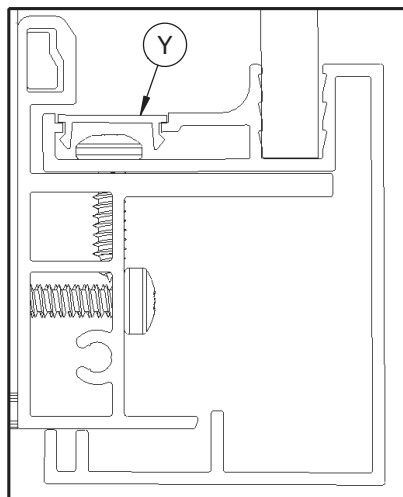
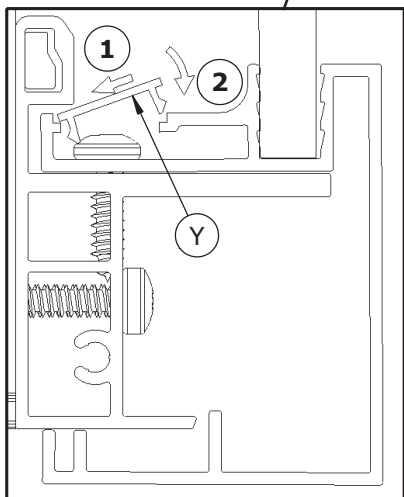
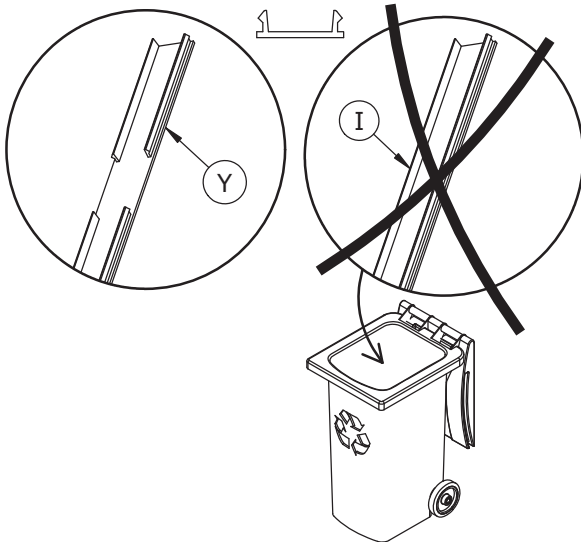

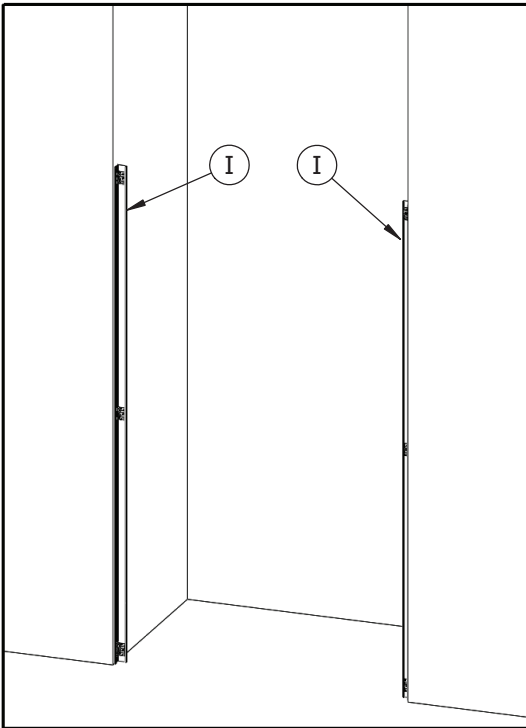

- Si receveur ● If shower tray
- Si plato ● Se piatto
- Als douchebak
- Wenn Duschanne

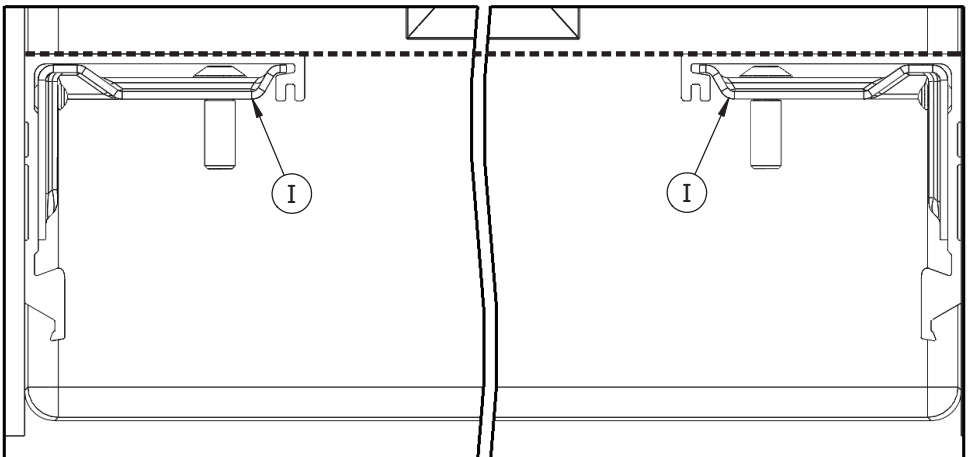
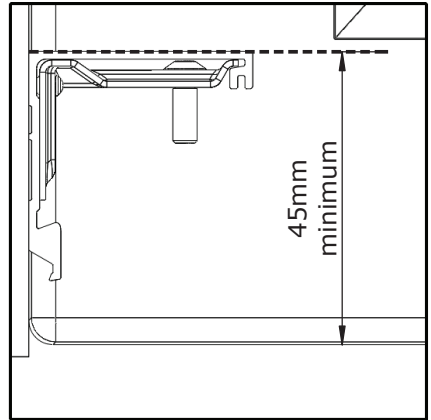

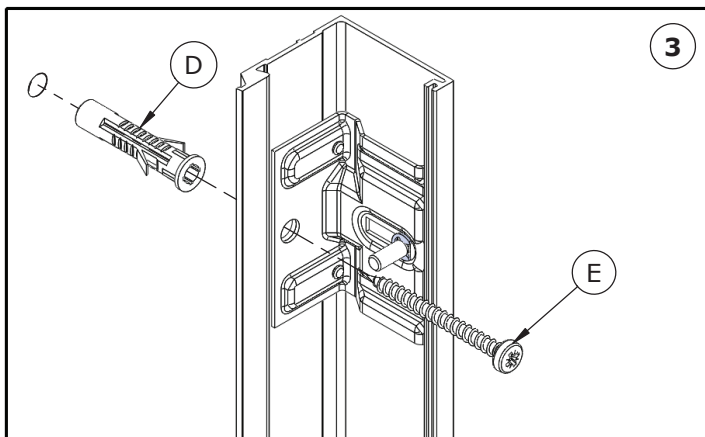
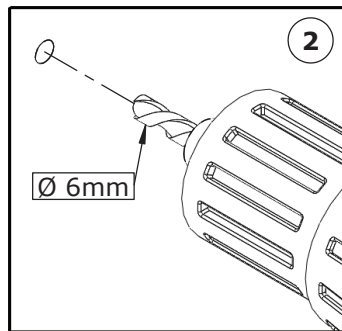
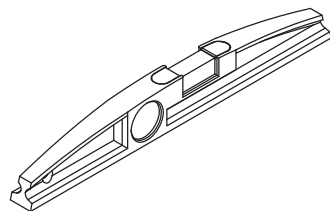
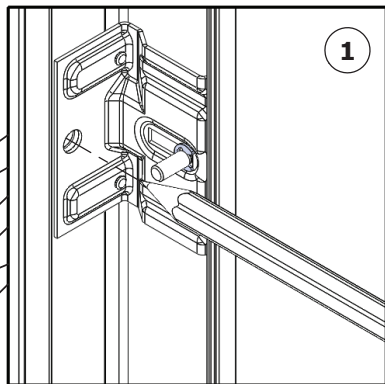
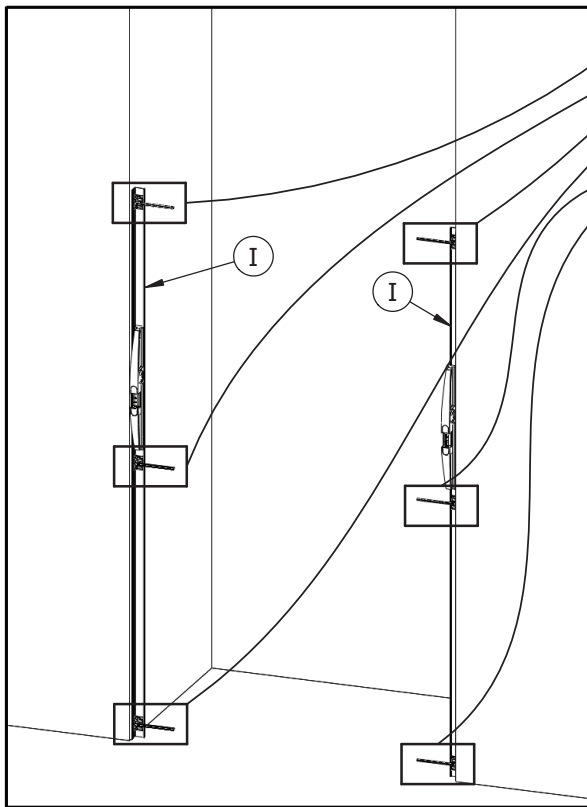

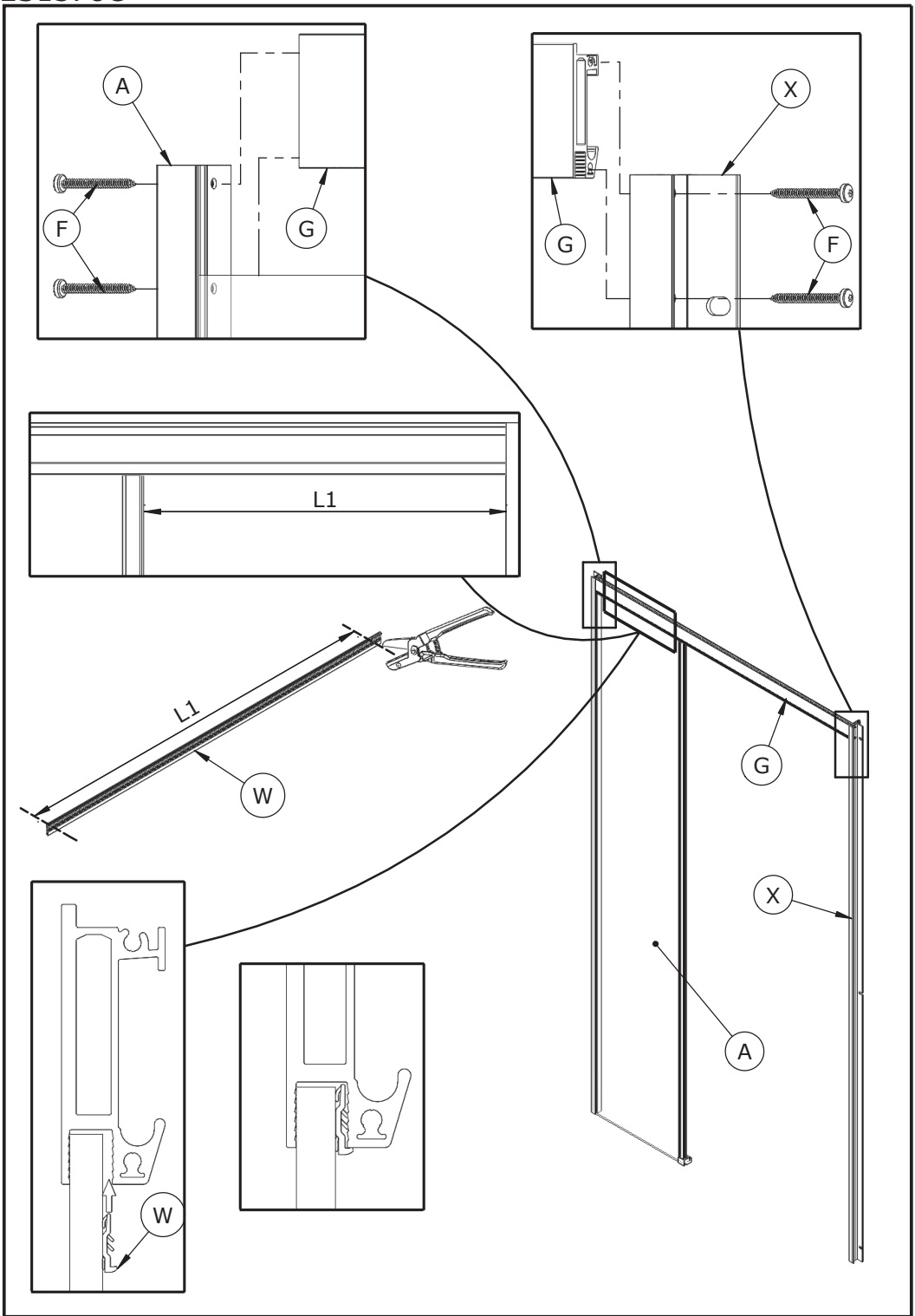

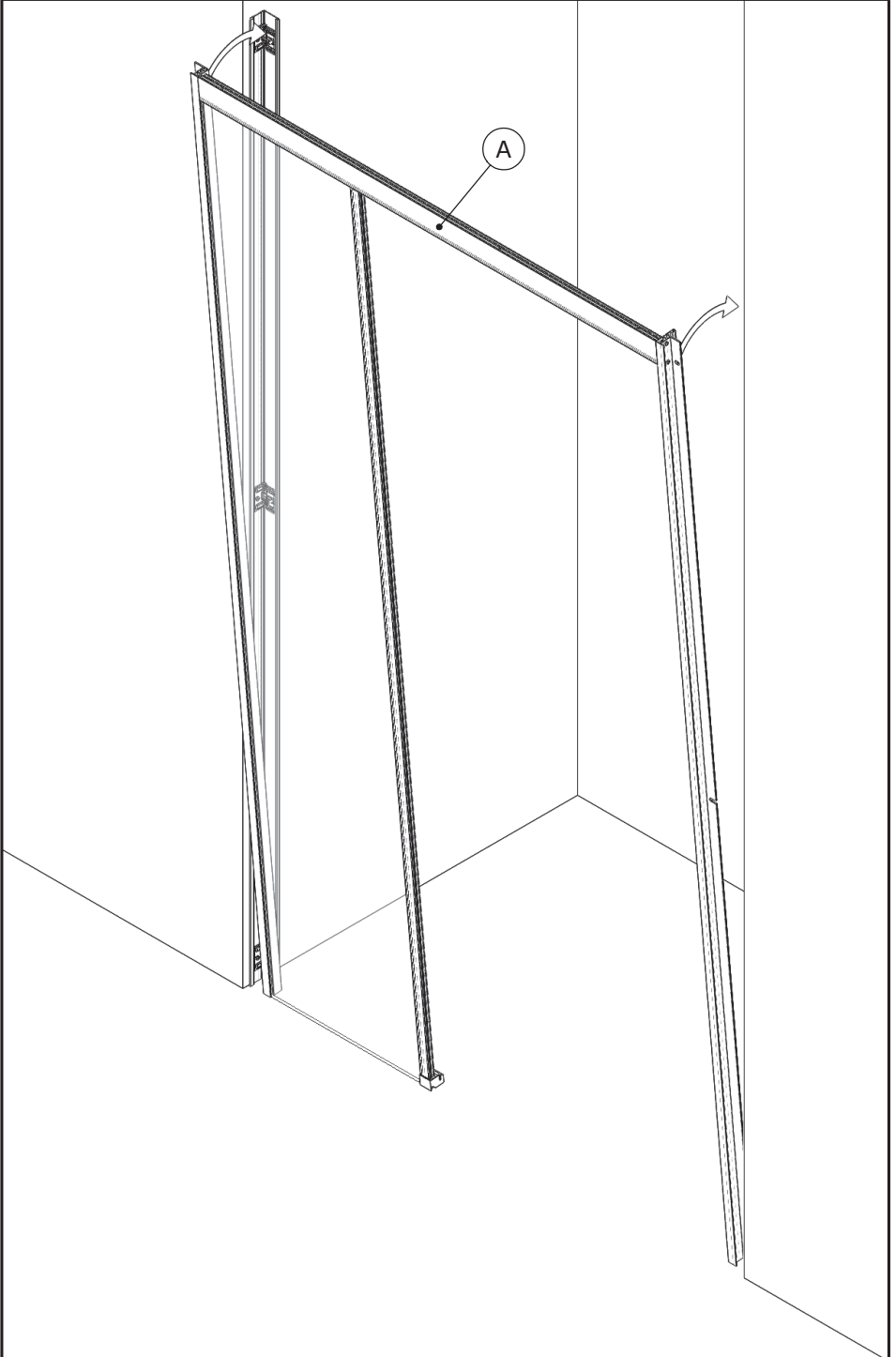

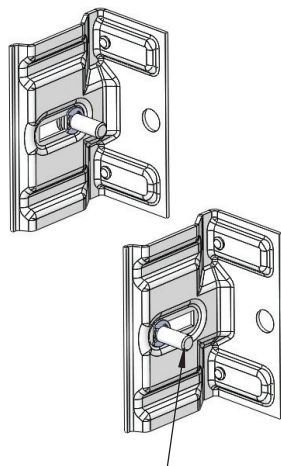
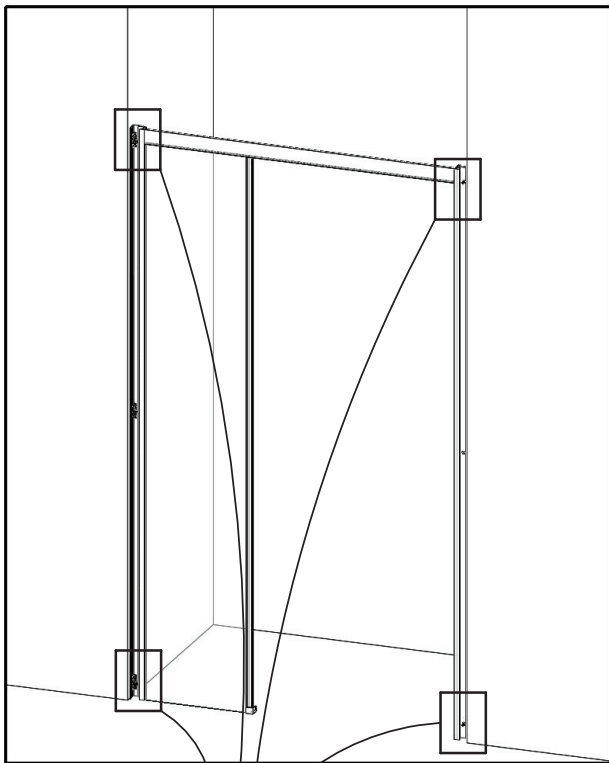

- Si nécessaire, desserrer, régler puis resserrer
- If necessary, loosen, adjust and retighten
- Si es necesario, afloje, ajuste y apriete
- Se necesario, allentare, regolare e stringere
- Draai los, indien nodig, stel af en draai vervolgens weer vast
- Falls erforderlich, lösen, einstellen und wieder festziehen

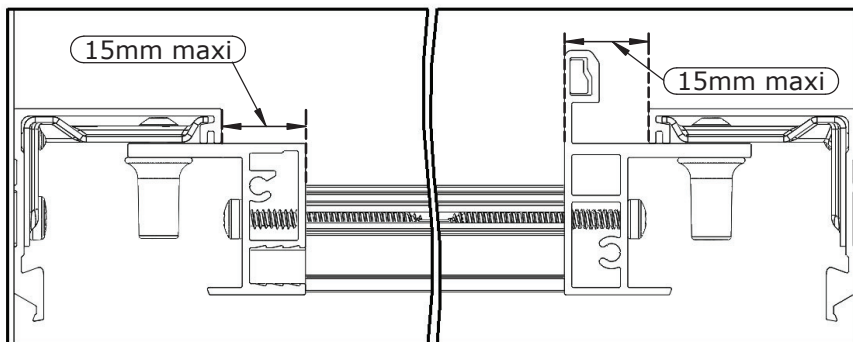
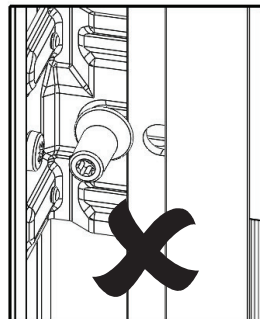
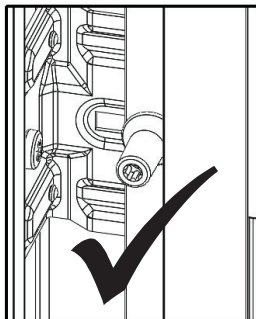
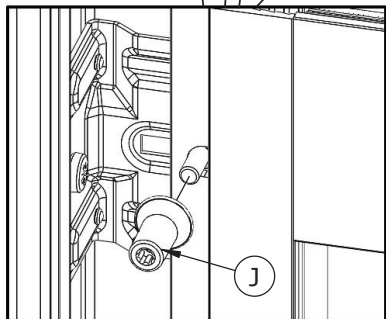

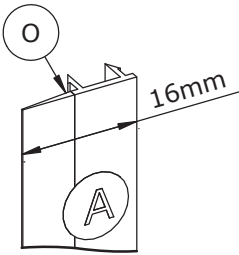

Lg=1938mm

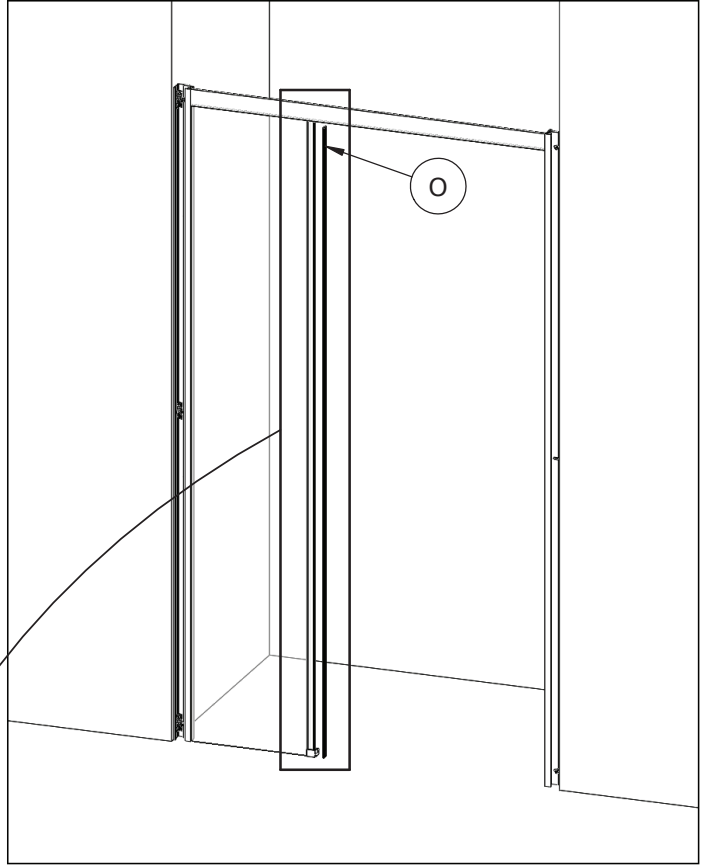

● Vue intérieur ● Interior view ● Vista interior
 ● Vista interna ● Binnen aanzicht ● Innenansicht

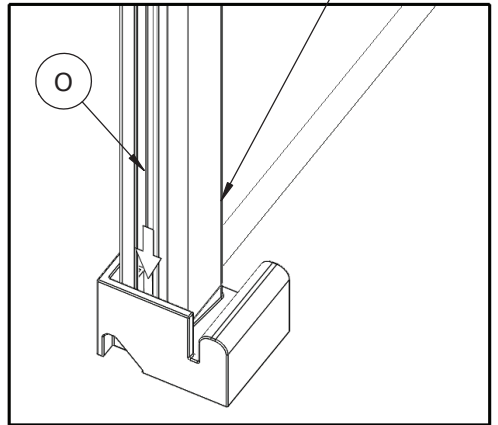
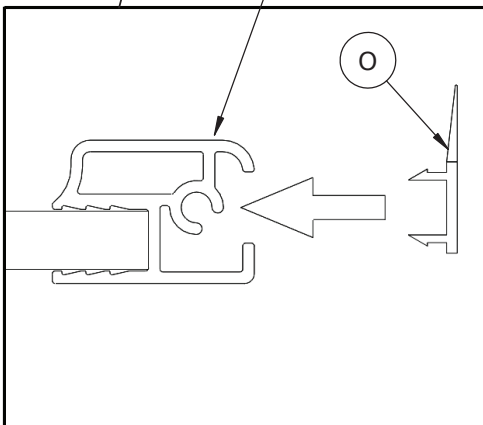

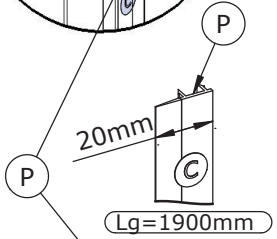
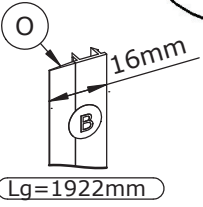
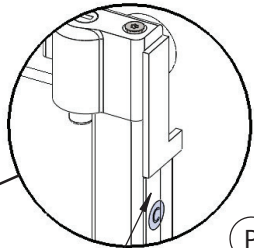
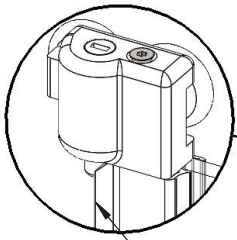

2

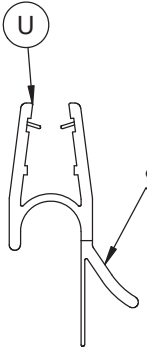
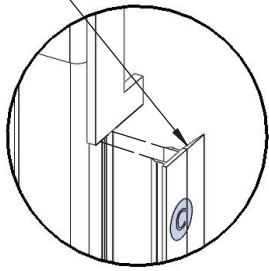
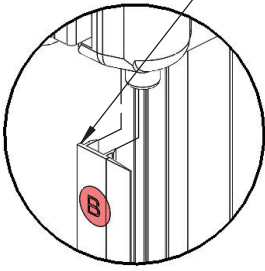

● Intérieur ● Inside
 ● Interior ● Interno
 ● Binnenkant ● Innen

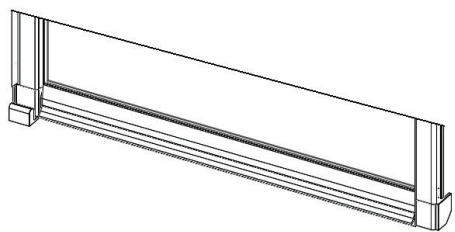
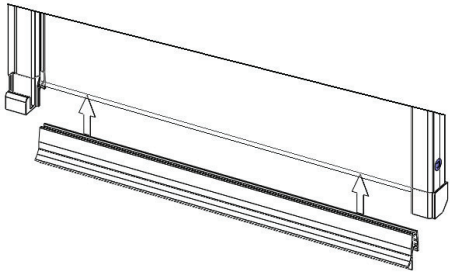
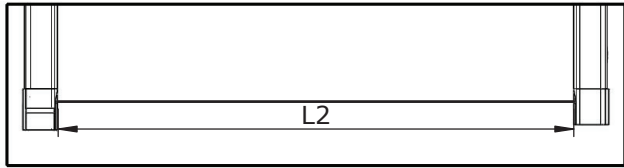

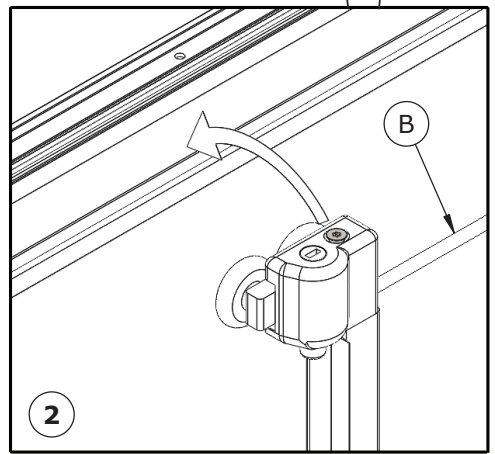
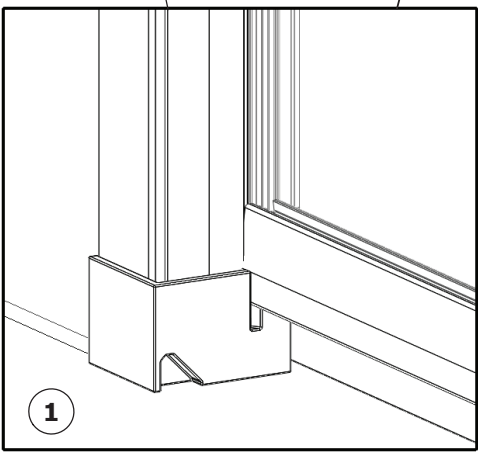
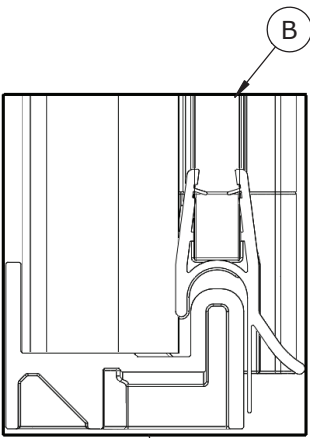
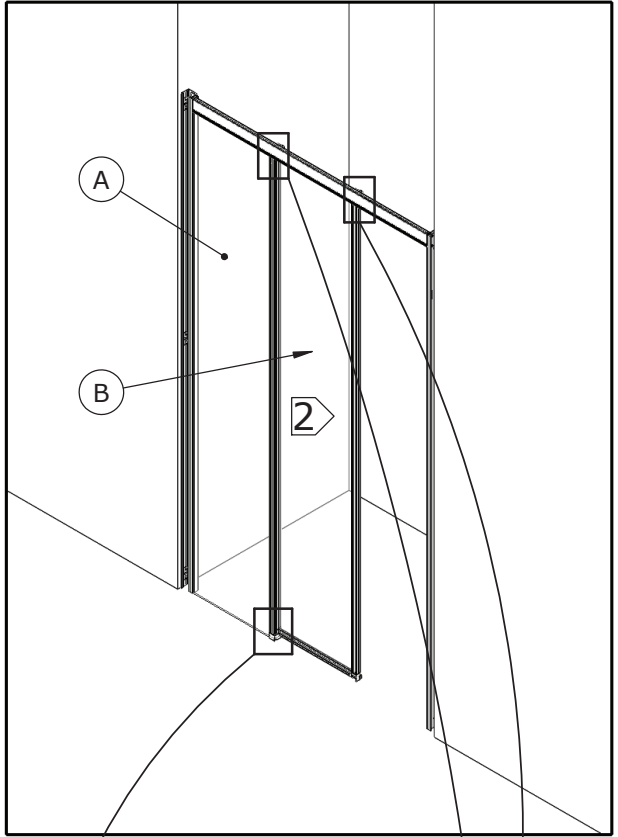

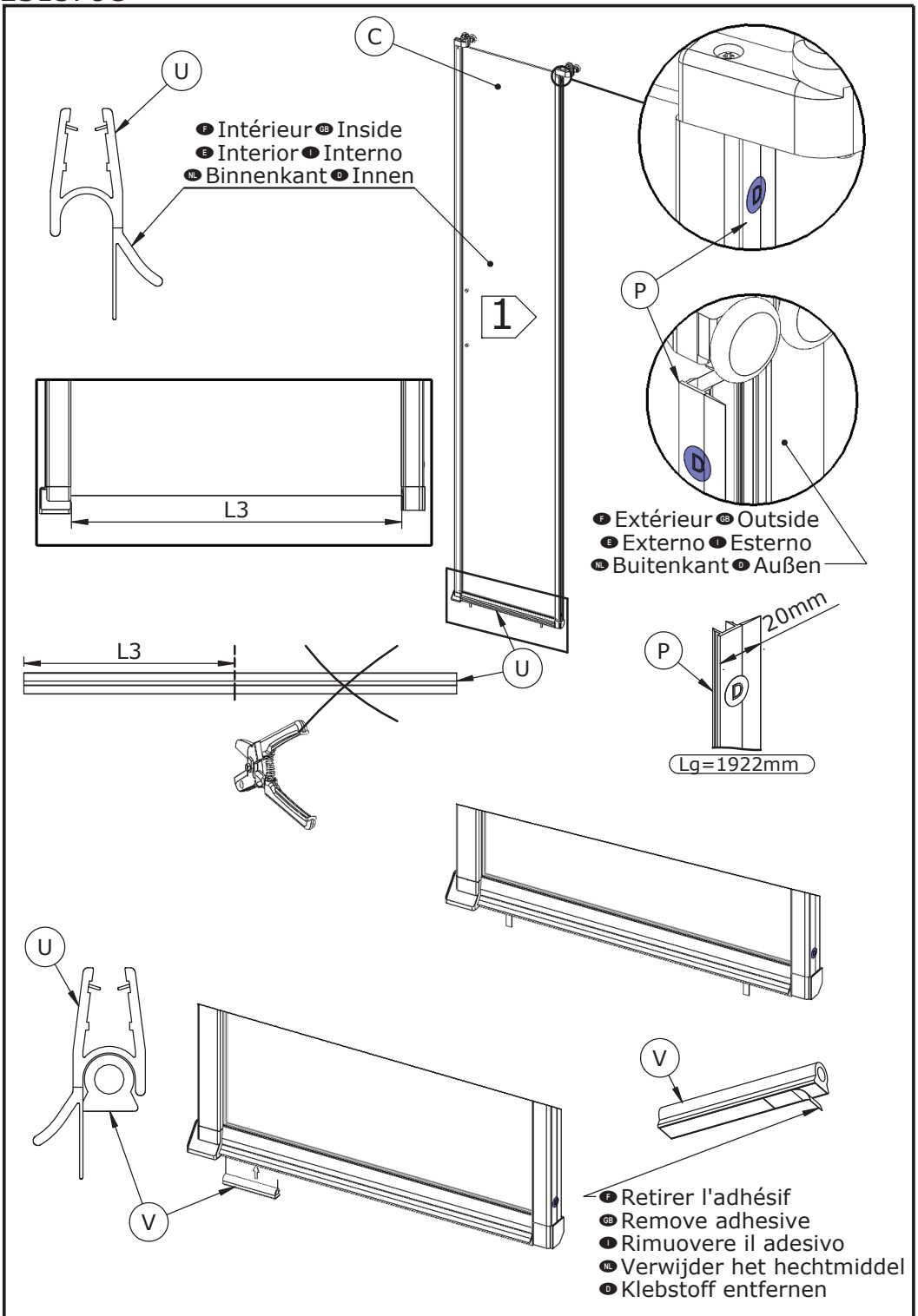

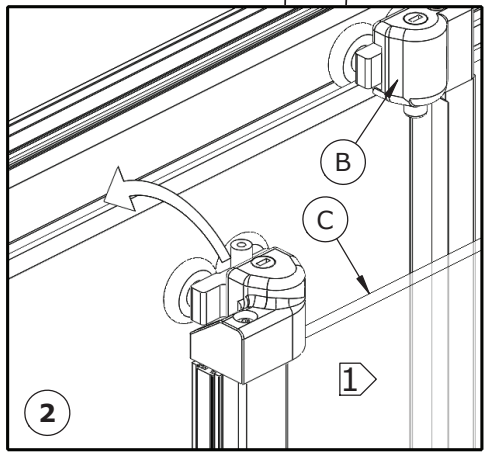
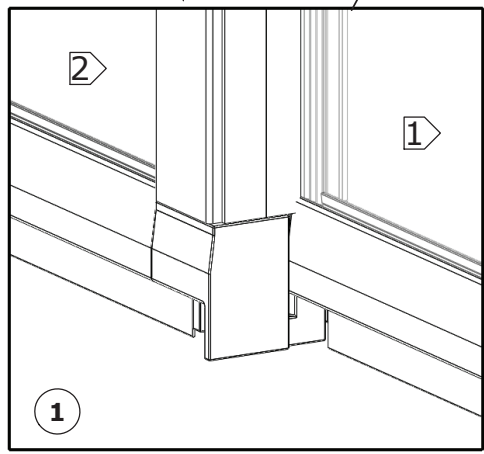
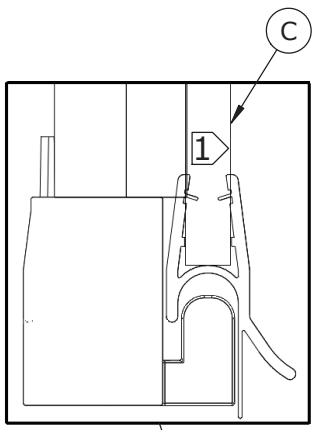
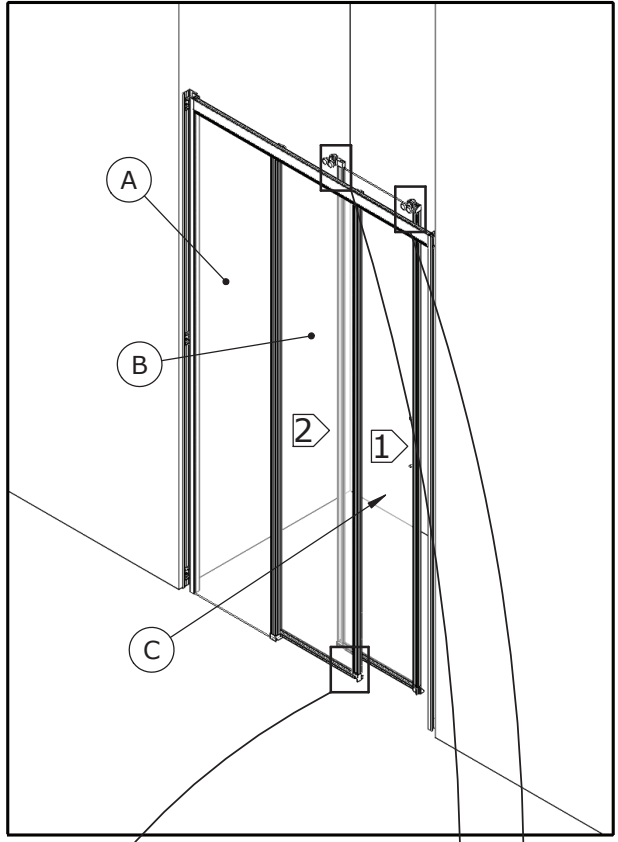

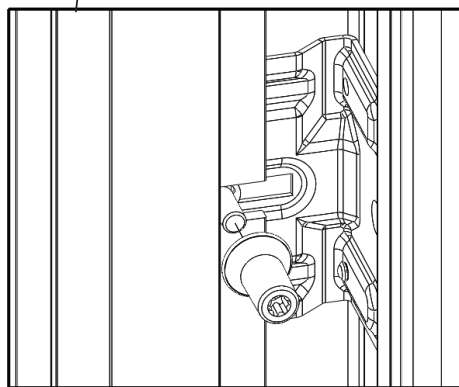
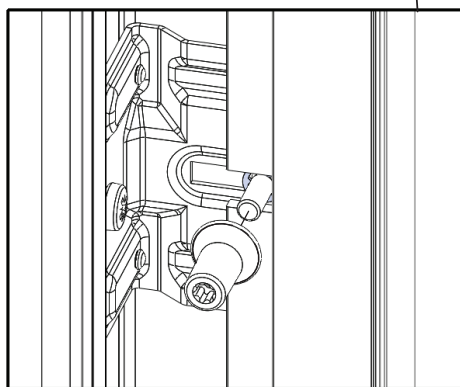
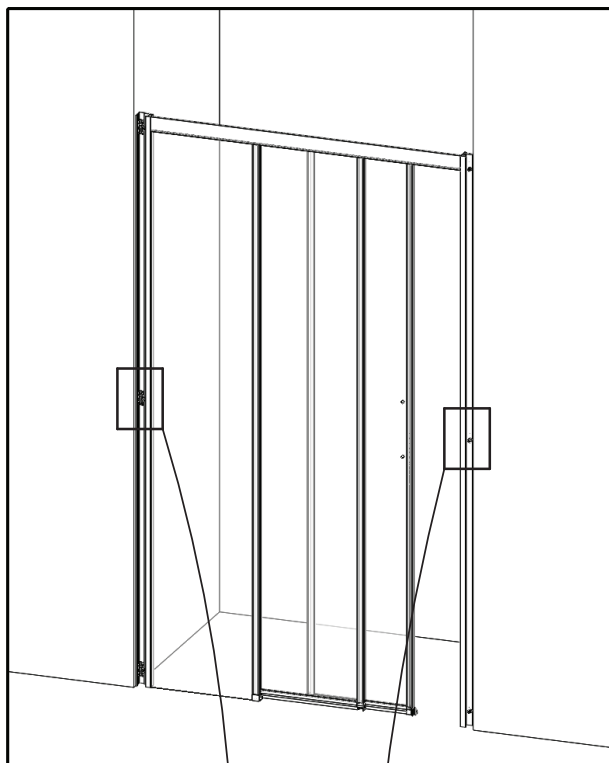
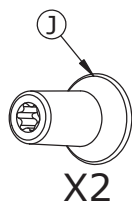

- Si nécessaire, desserrer, régler puis resserrer
- If necessary, loosen, adjust and retighten
- Si es necesario, afloje, ajuste y apriete
- Se necesario, allentare, regolare e stringere
- Draai los, indien nodig, stel af en draai vervolgens weer vast
- Falls erforderlich, lösen, einstellen und wieder festziehen

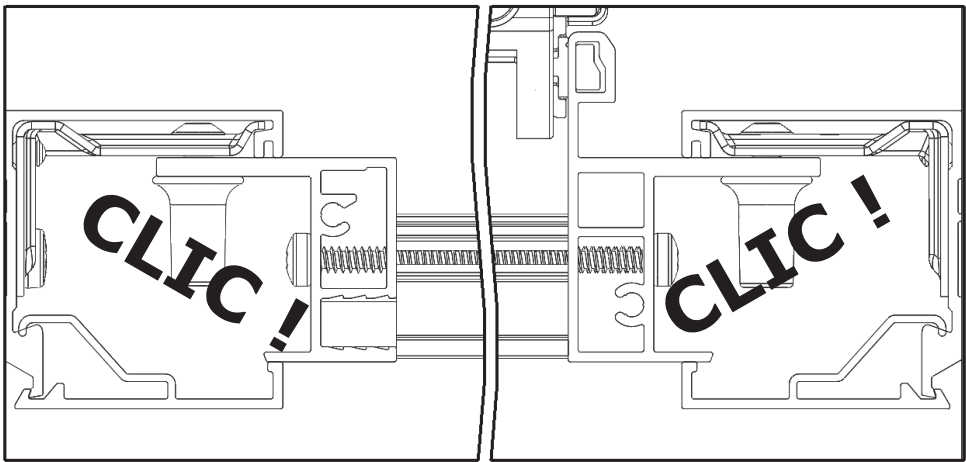
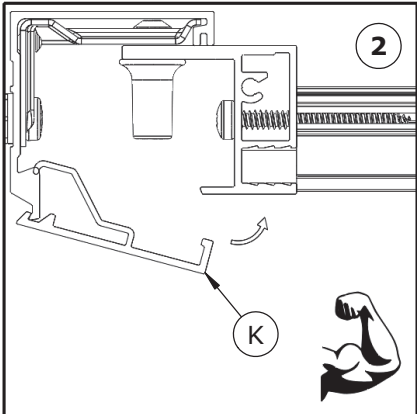
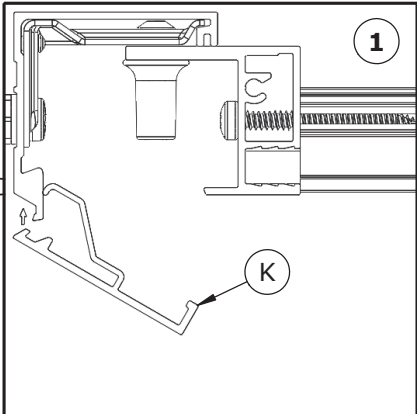
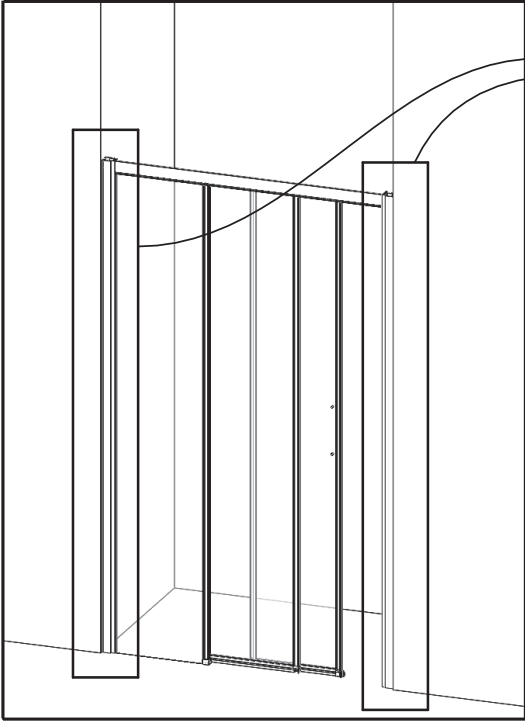

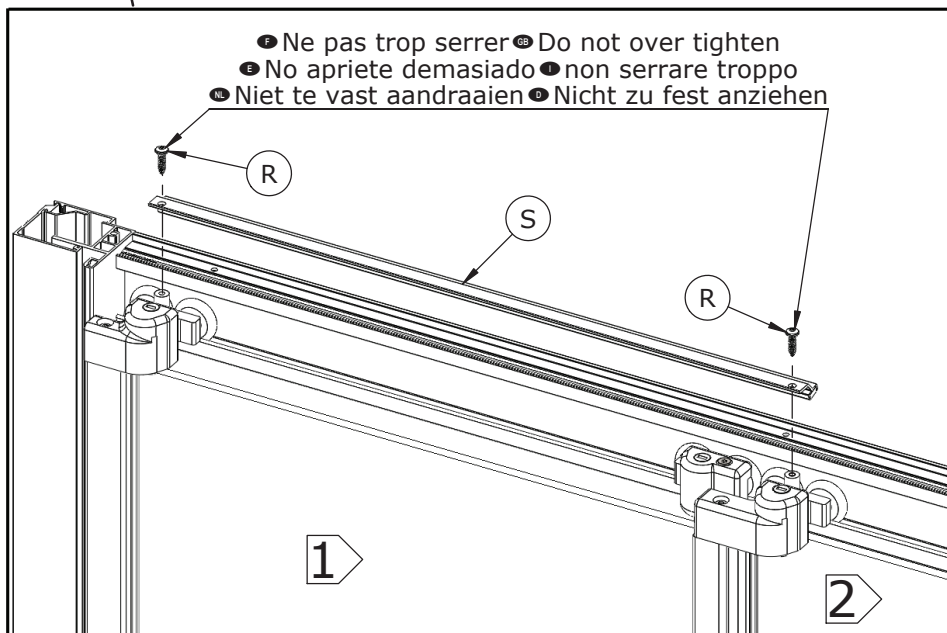
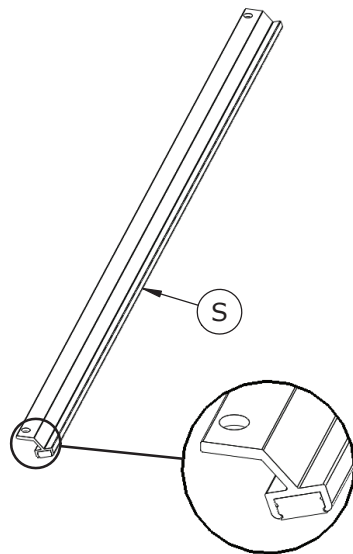
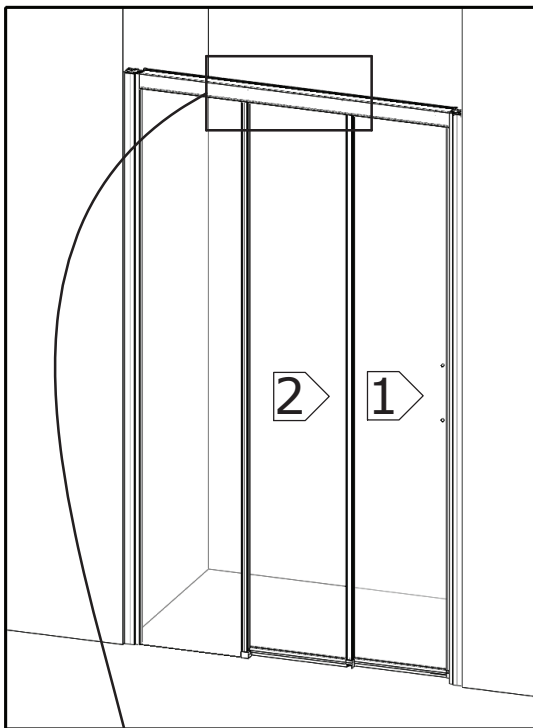

- Réglage des portes
- Door adjustment
- Regulación de puerta
- Regolazione porte
- Deuren afstellen
- Ausrichten und Einstellen

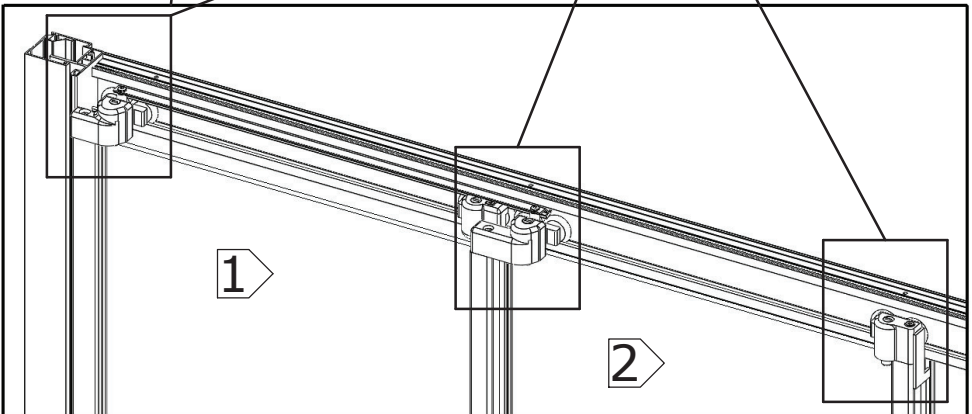
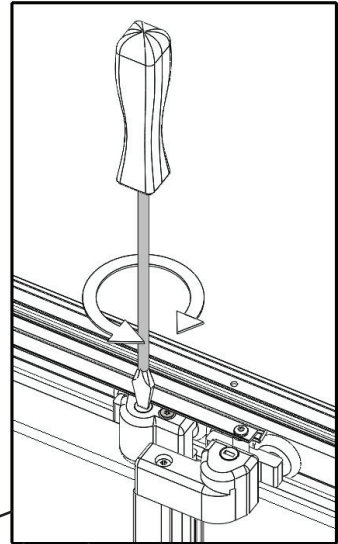
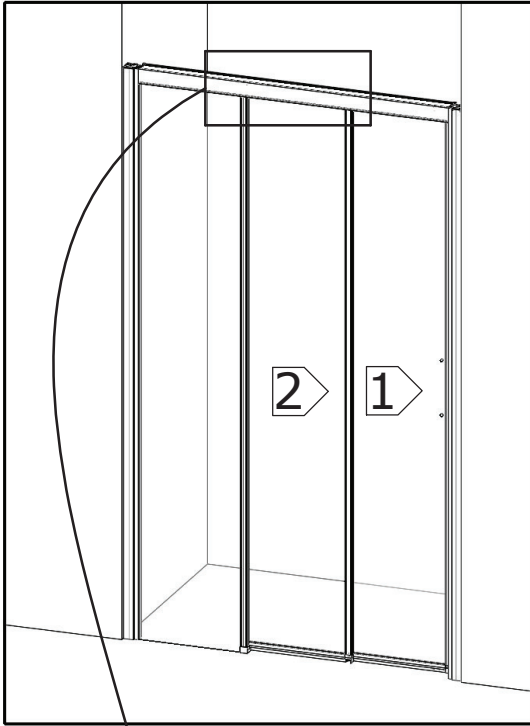

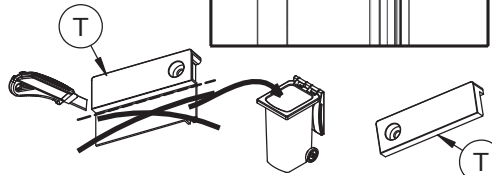
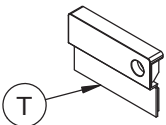
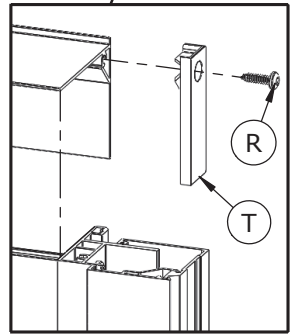
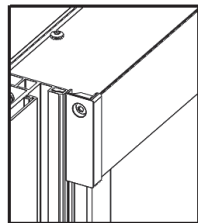
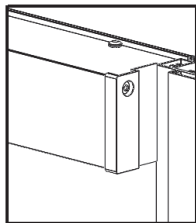
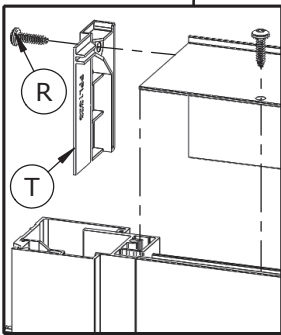
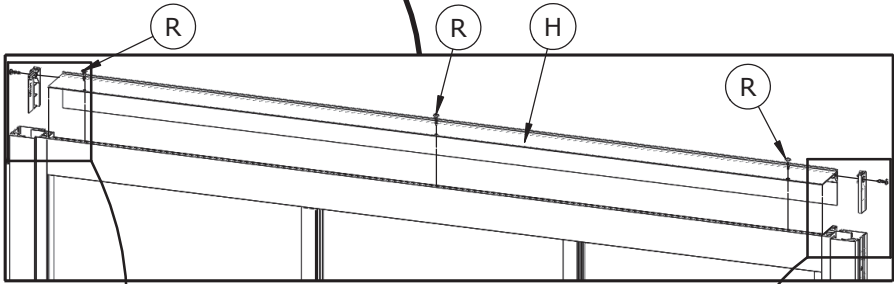
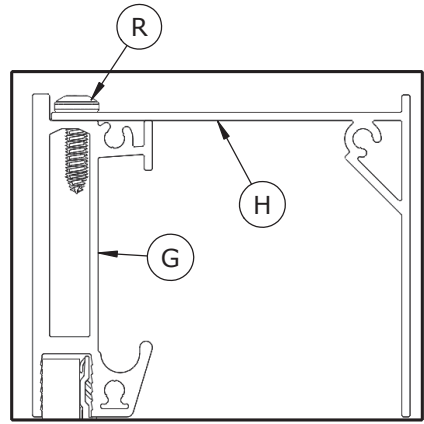
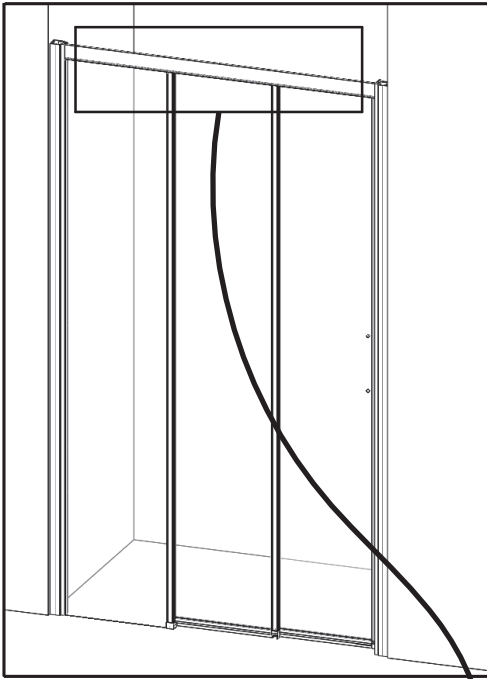

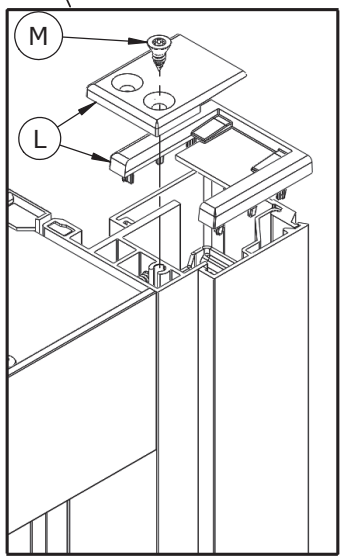
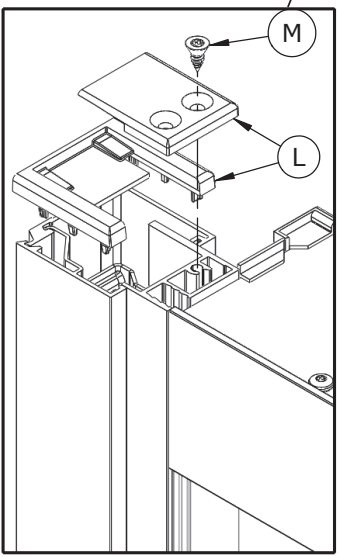
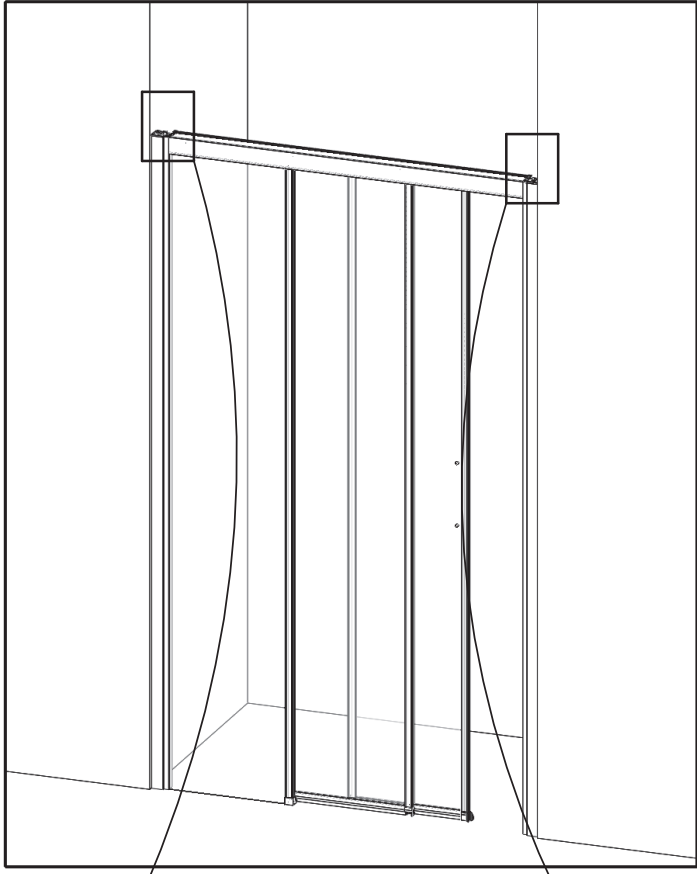

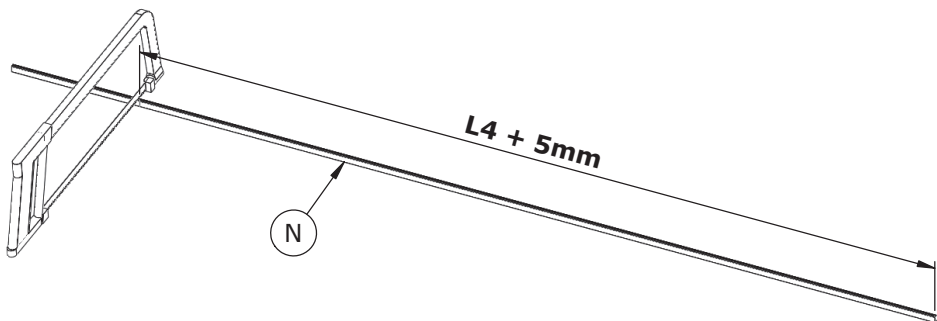
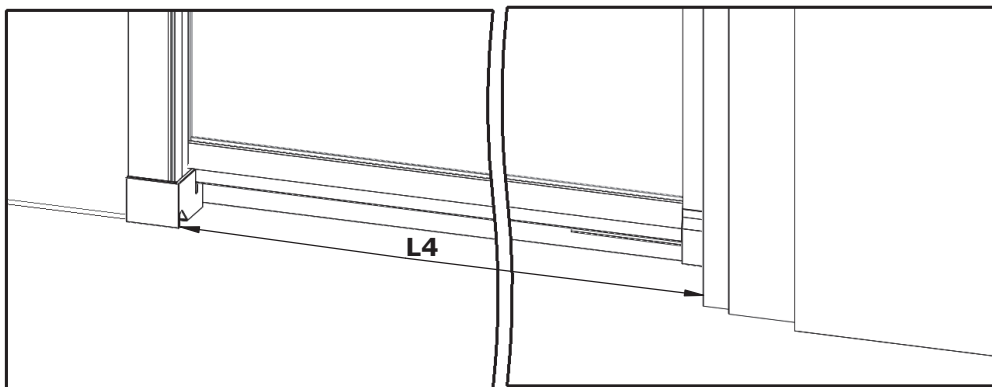
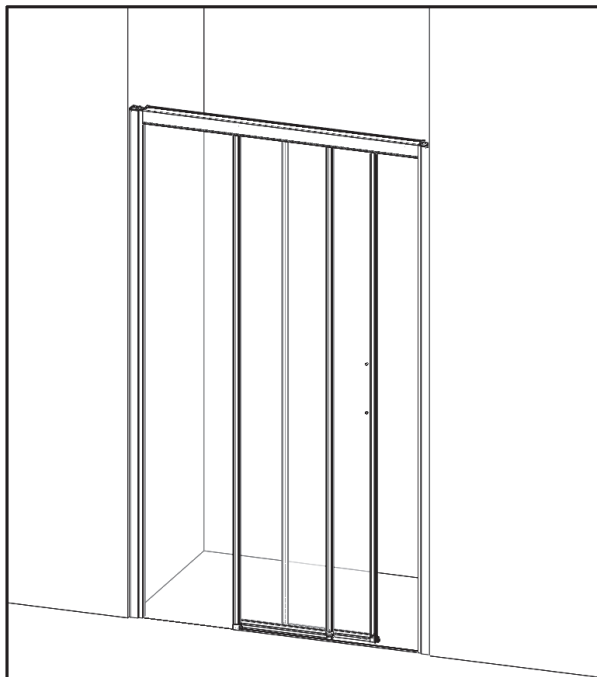

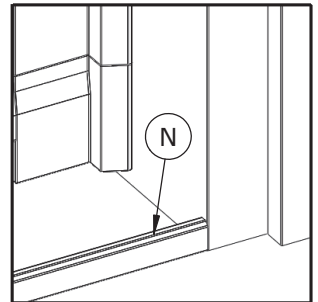
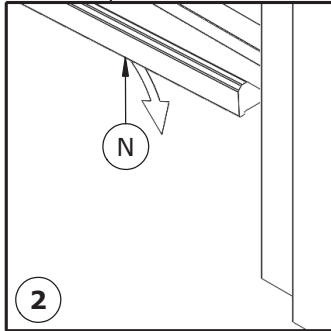
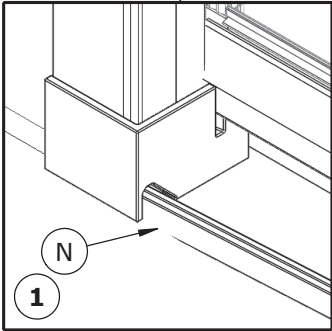
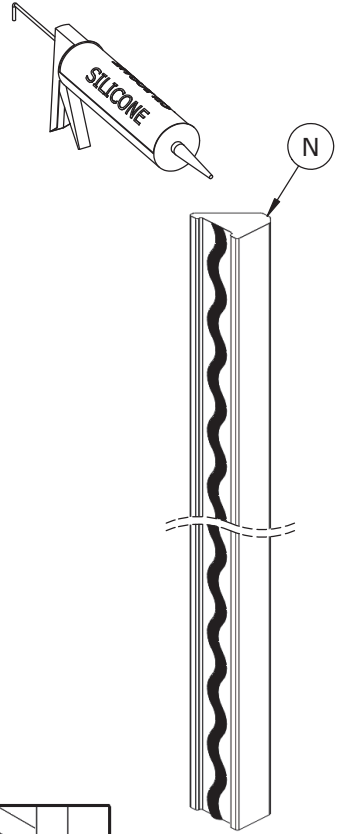
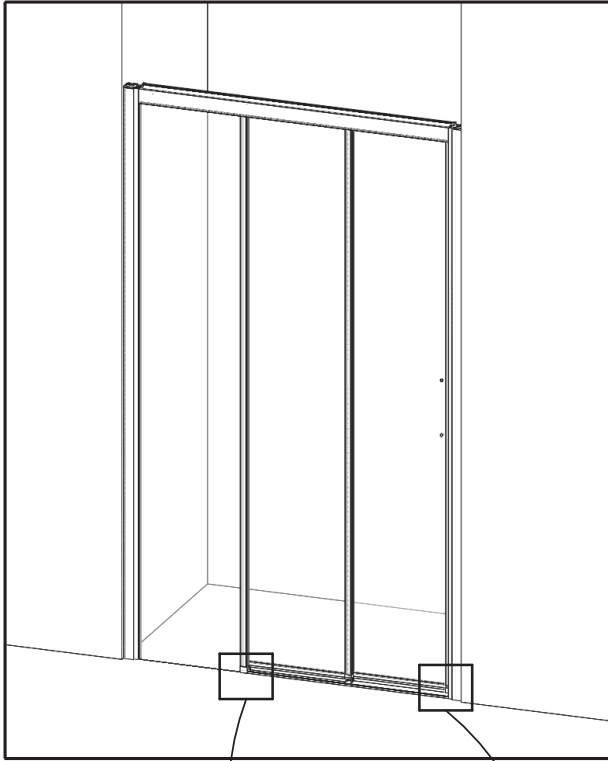

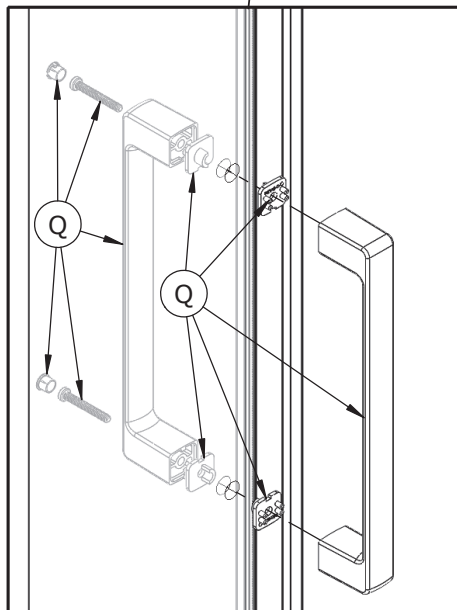
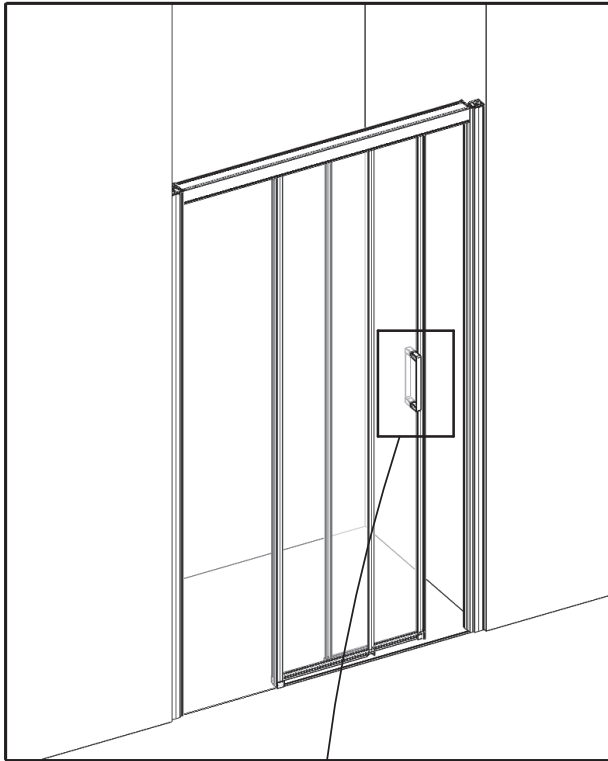

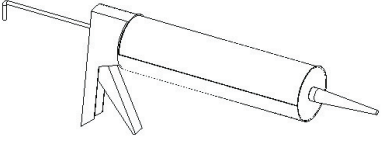

24H

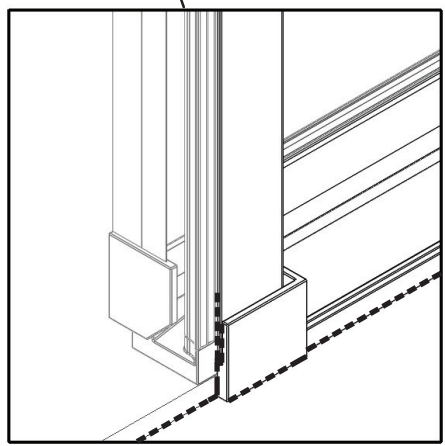
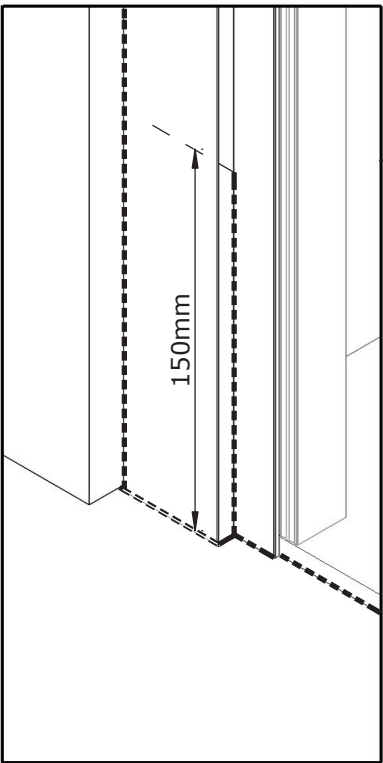
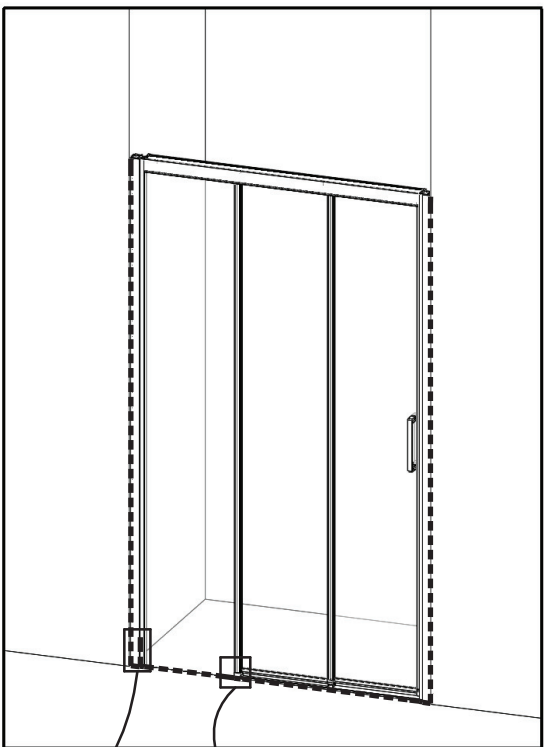



SAV
SERVICE HELPLINES
ASSISTENZA POST-VENTITA
SERVICIO POSTVENTA

FRANCE

02 40 21 29 45

UK

020 8842 0033

IRELAND

04697 33102

DEUTSCHLAND

+49 (0) 6074 / 30928 0

ITALIA

(0382) 6181

OSTEREICH

+43 1 710 60 70

SCHWEIZ

(01) 748 17 44

ESPANA

93 544 60 76

NEDERLAND

+31 475 487 100

BELGIE

+31 475 487 100

BELGIQUE

+31 475 487 100

РОССИЯ

963 19 40, 773 67 22



AQUAPRODUCTION, Site industriel,
 F - 44680 Chaumes-en-Retz

18

EN 14428

Paroi de douche, fabriquée en verre de silicate
 sodo-calcique de sécurité trempé thermiquement

Aptitude au nettoyage : réussite

Résistance à l'impact/propriétés de fragmentation : réussite

Durabilité : réussite

28