

FAR one® TOOLS

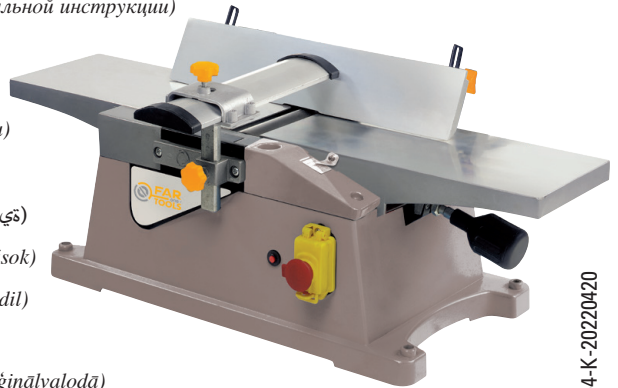

RB 1800D Simple Machine

- FR** *Dégauchisseuse (Notice originale)*
- EN** *Jointer (Original manual translation)*
- DE** *Elektrohobel (Übersetzung aus dem Original-Anleitung)*
- ES** *Pialla elettrica (Traducción del manual de instrucciones originale)*
- IT** *Pialla a filo (Traduzione dell'avvertenza originale)*
- PT** *Maquina de Aplinar (Tradução do livro de instruções original)*
- NL** *Elektrische Schaafmachine (Vertaling van de originele instructies)*
- EL** *Ηλεκτρική Πλεάνη (Μεταφραση από τις πρωτότυπες οδηγίες)*
- PL** *Strugarka Elektryczna (Tłumaczenie z oryginalnej instrukcji)*
- FI** *Sähköhöylä (Käännös alkuperäisestä ohjeet)*
- SV** *Elhyvel (Översättning från originalinstruktioner)*
- BU** *Електрическо ренде. (Превод на оригиналната инструкция)*
- DA** *Elektrisk høvl (Oversættelse fra oprindelige brugsanvisning)*
- RO** *Rindea electric (Traducere din instrucțiunile originale)*
- RU** *Электрический строг (Перевод с оригинальной инструкции)*
- TU** *Elektrikli rende (Orijinal talimatlar çeviri)*
- CS** *Srovnávací (Překlad z originálního návodu)*
- SK** *Porovnávacie (Preklad z originálneho návodu)*
- HE** *תירוקמ תוארומה סוגרת). תילמשח העוצקמ*
- AR** *(تعليمات العمل) من قمت العمل). يئالبرك رجنم*
- HU** *Elektromos gyalu (Fordítás az eredeti utasítások)*
- SL** *Elektrini nadrezkar (Prevod iz izvornih navodil)*
- ET** *Freesimispink (Tõlge originaal juhiseid)*
- LV** *Stacionārā ēvele (Tulkojumā no instrukcijas oriģinālvalodā)*
- LT** *Stacionarus oblius (Vertimas iš originalių instrukcijas)*
- HR** *Mistrija (Vertimas iš originalių instrukcijas)*



© FAR GROUP EUROPE

113395-4-K-20220420

fartools.com

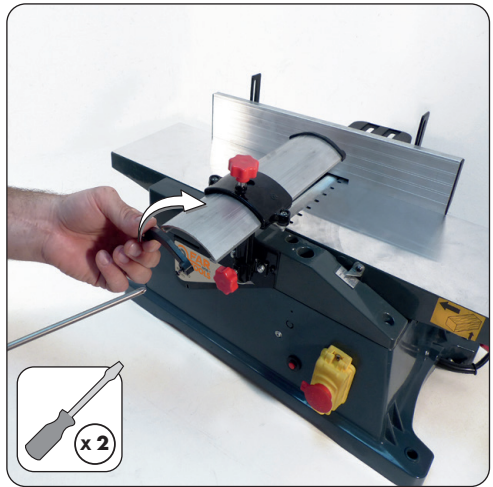
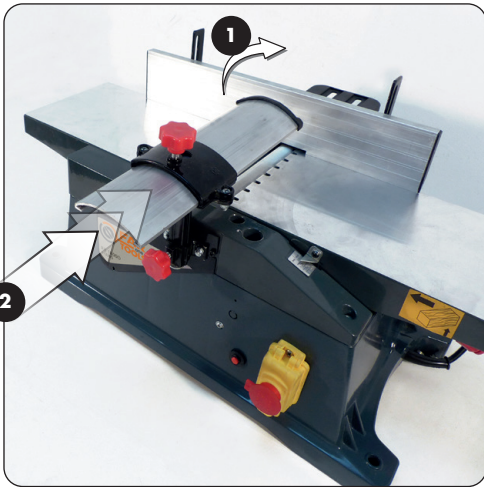
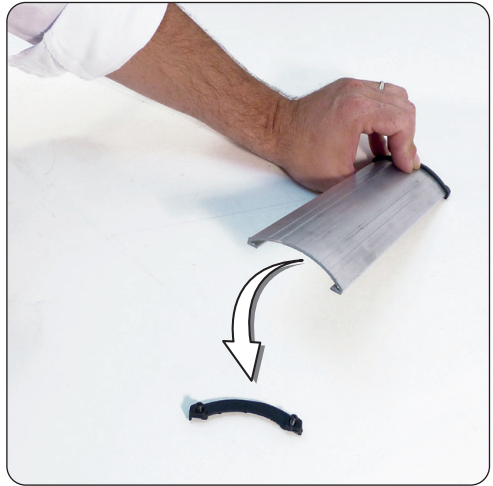



FR
 Cet appareil
 et ses accessoires
 se recyclent

À DÉPOSER
 EN MAGASIN

À DÉPOSER
 EN DÉCHÈTERIE

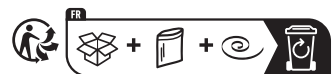

 OU
 

Points de collecte sur www.quefairede mesdechets.fr
 Privilégiez la réparation ou le don de votre appareil !

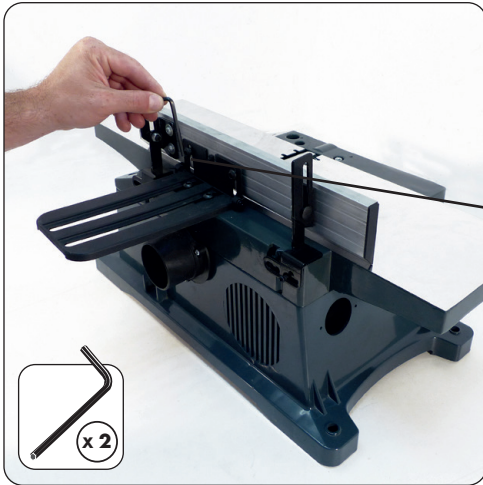

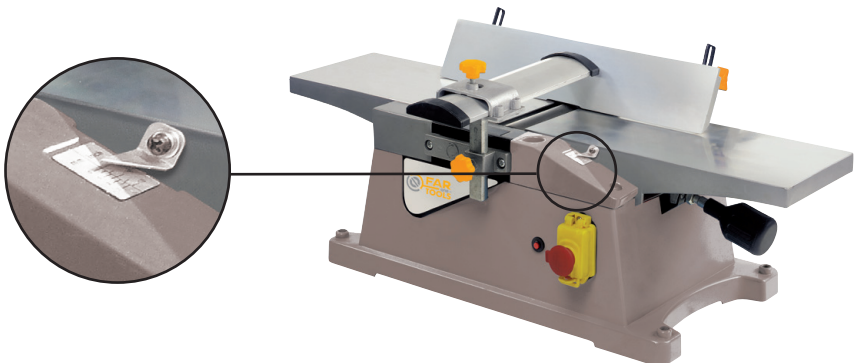
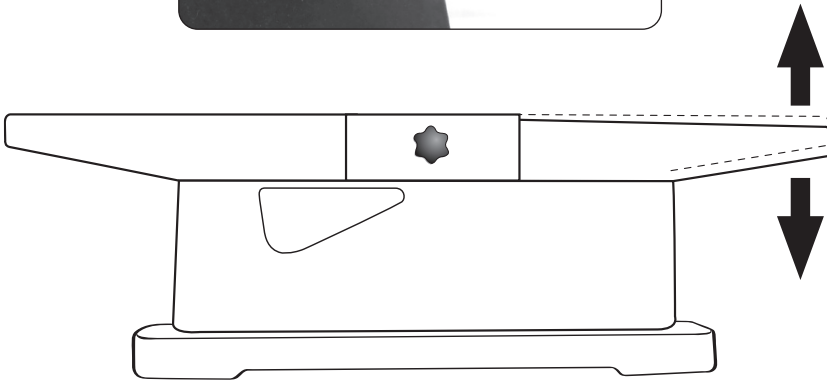
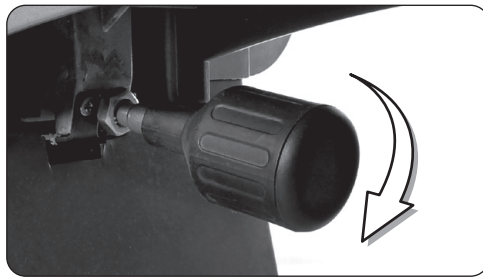
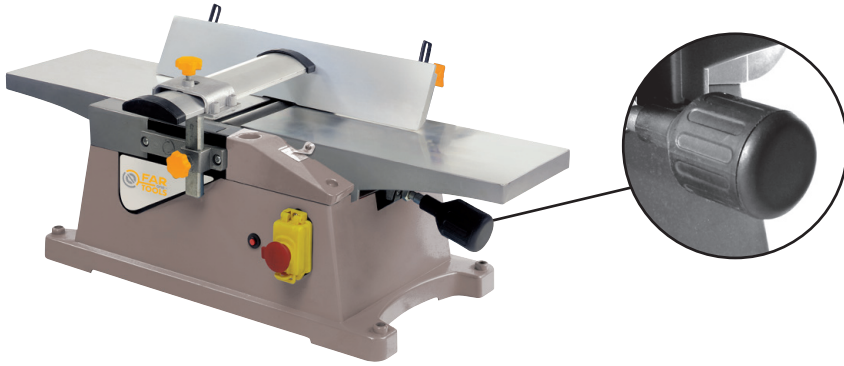

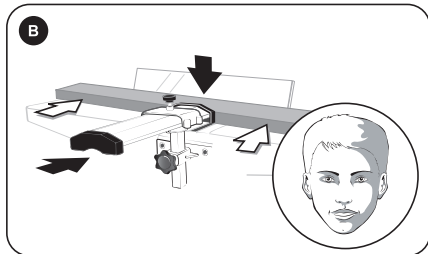
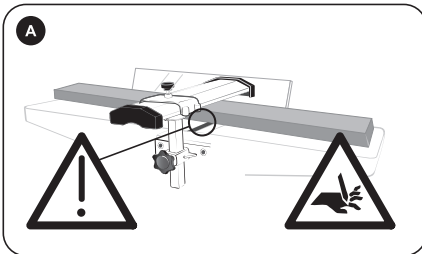
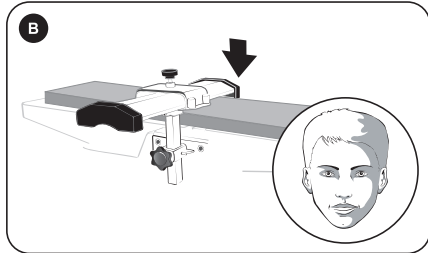
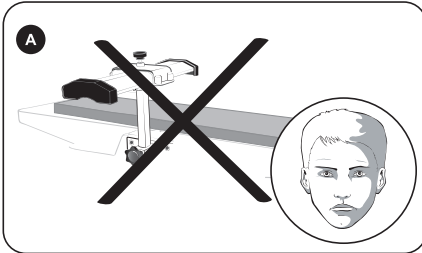
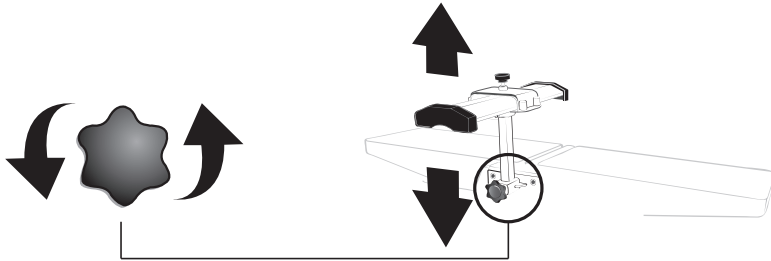
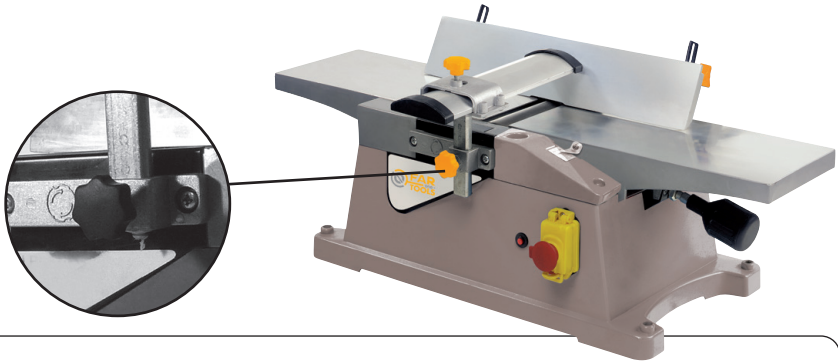



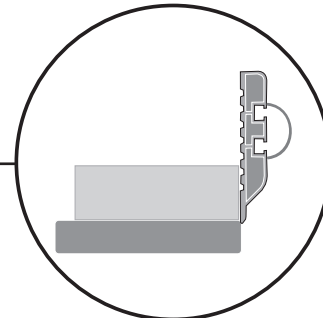
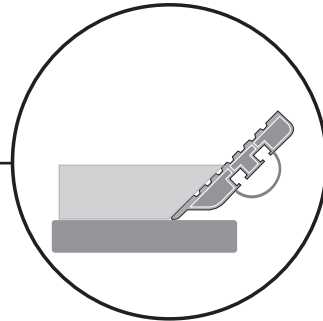
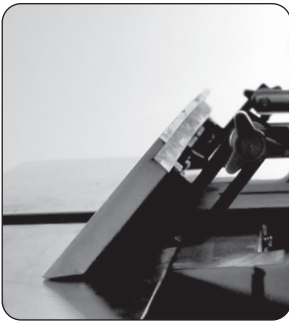
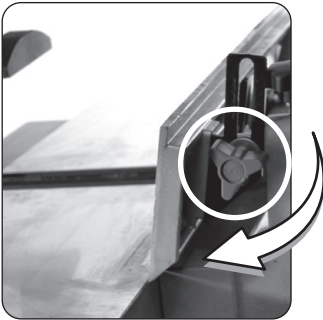
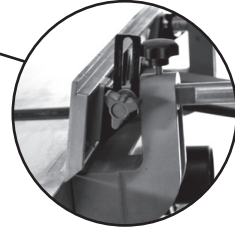
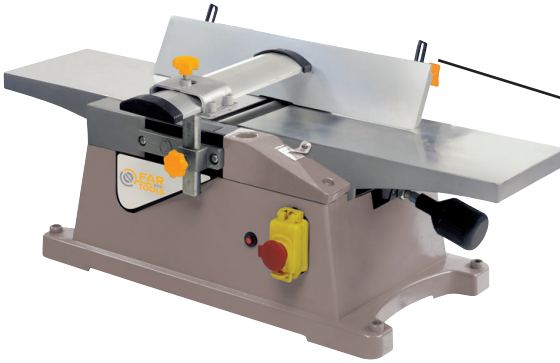

ATTENTION! / WARNING!

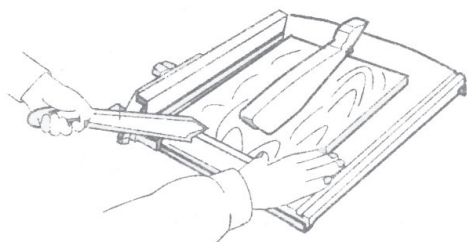
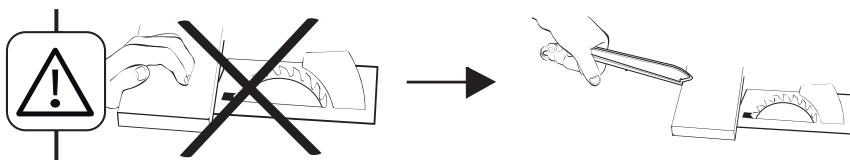

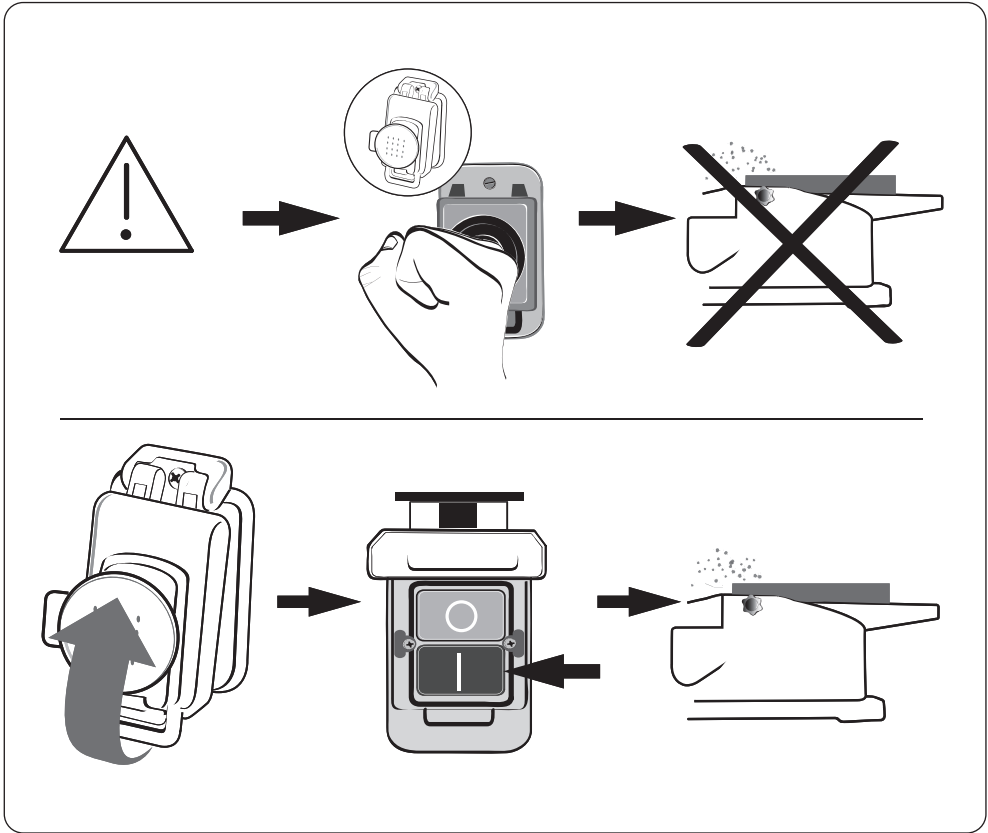
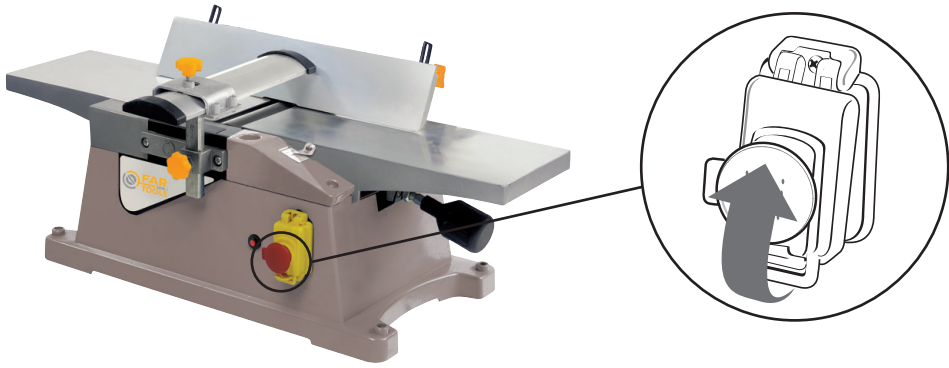

Protection thermique - Thermische beveiliging - La protección térmica -
A proteção térmica - Protezione termica - Thermal protection

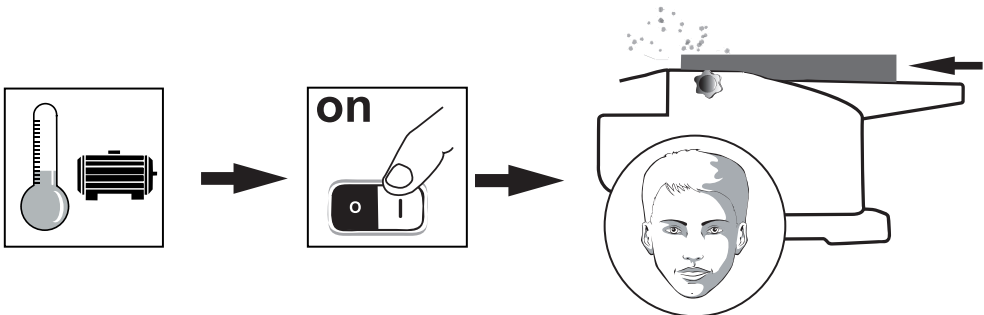
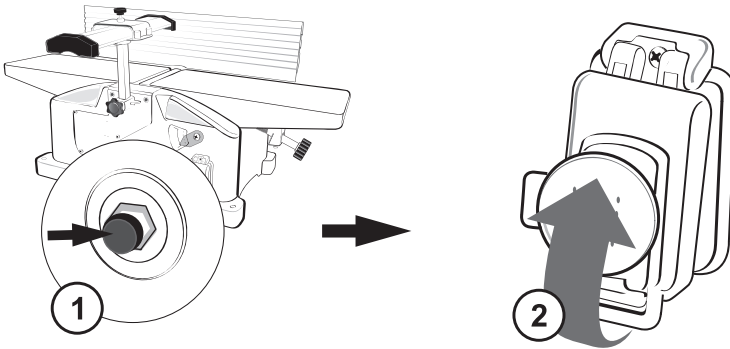
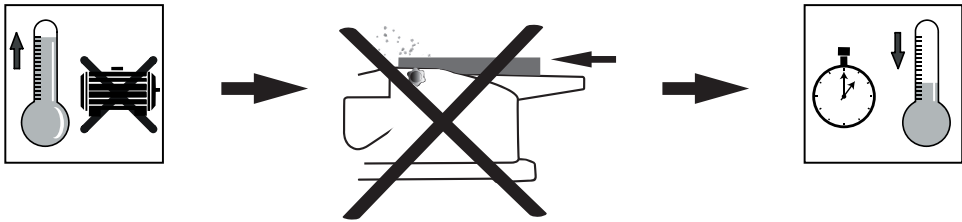
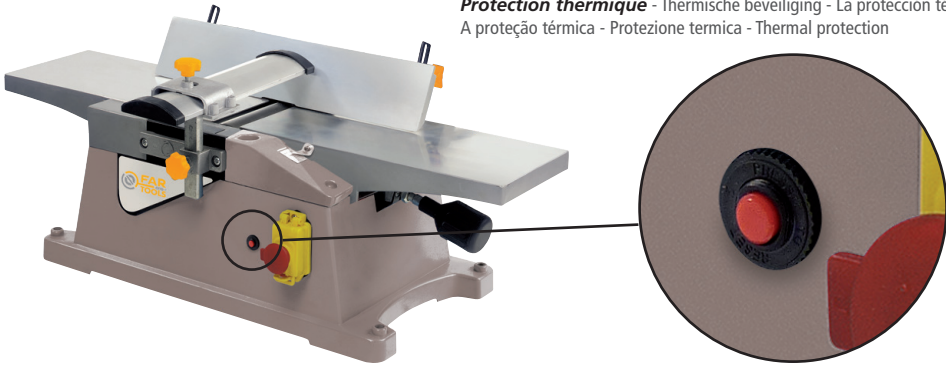

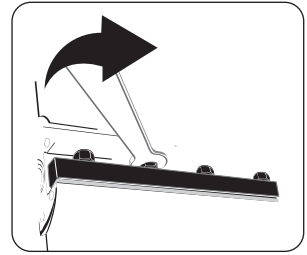
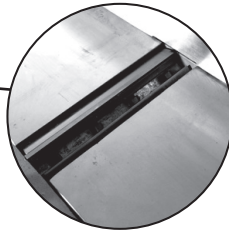
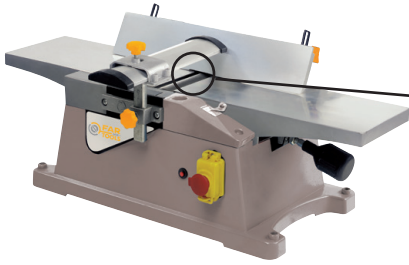



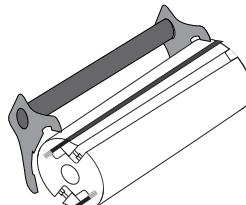
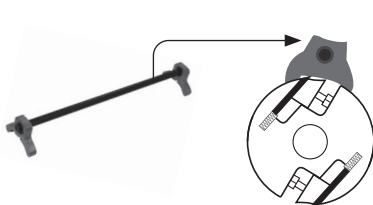
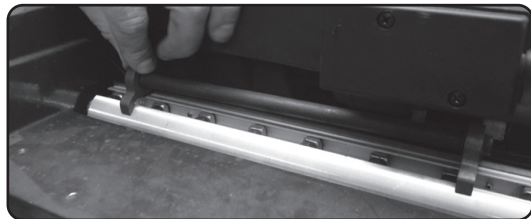
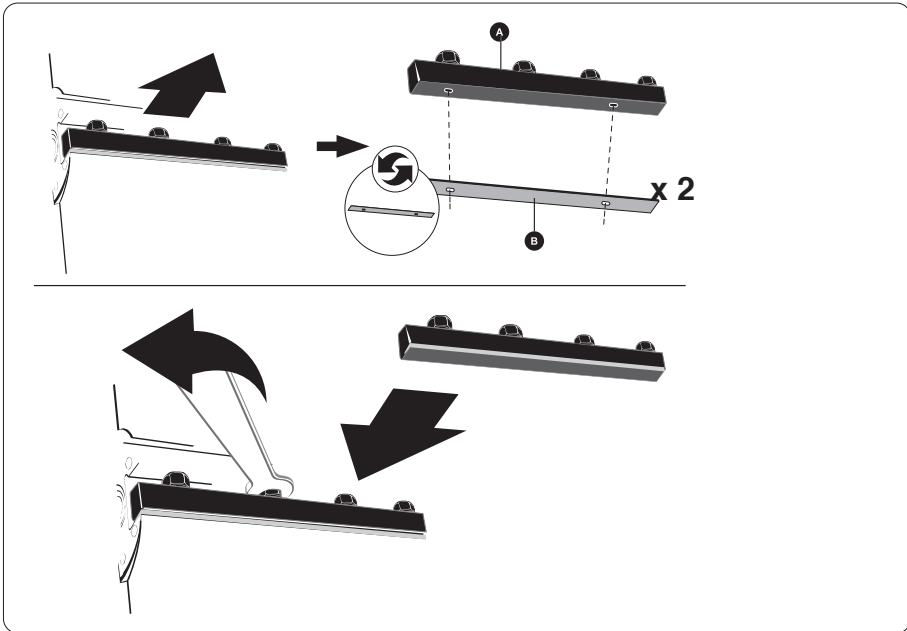

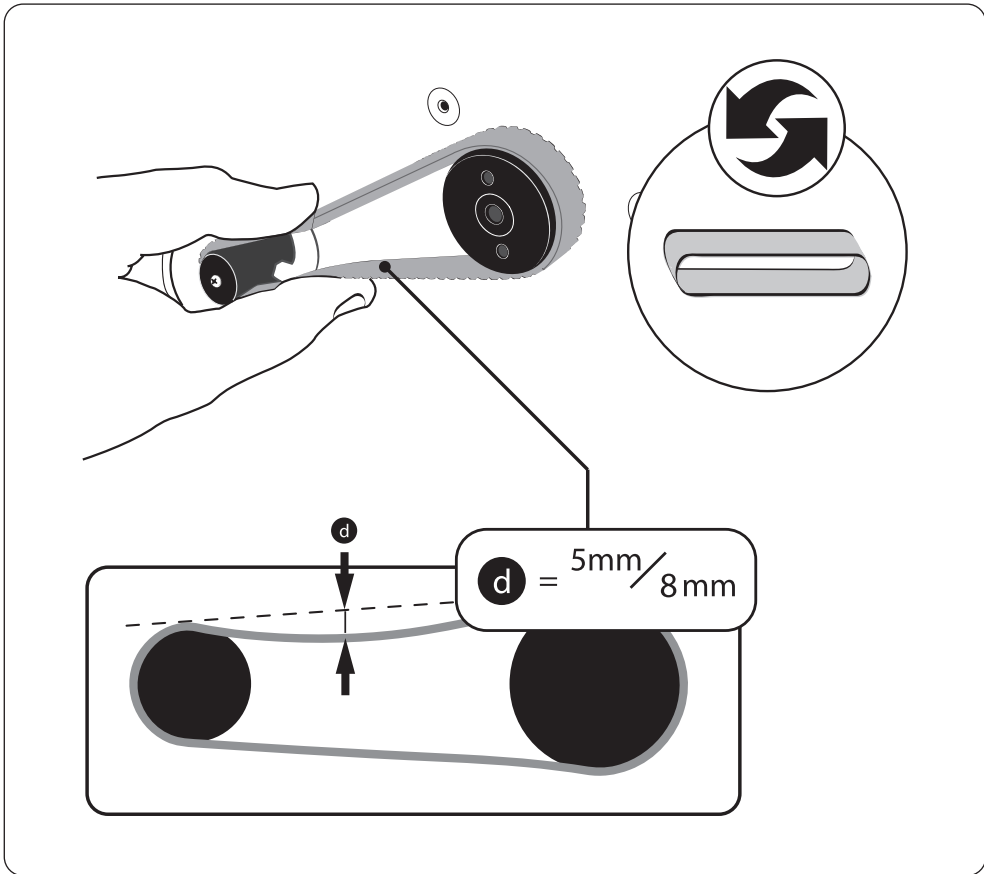
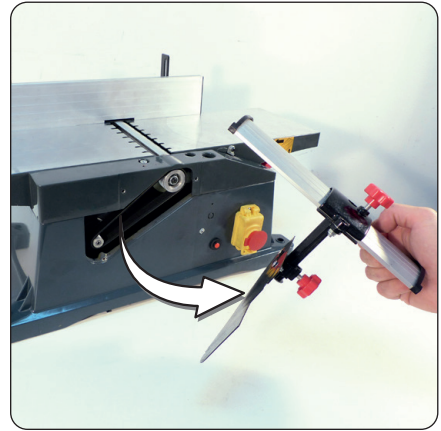
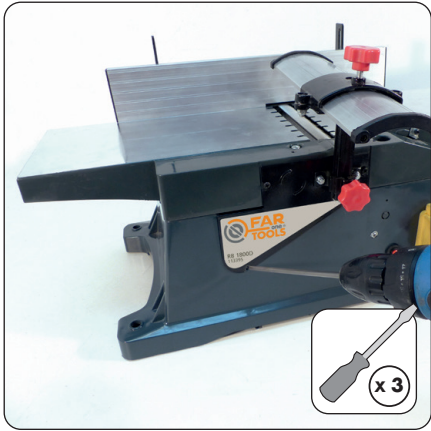
113899
155 x 20 x 3 mm
Lame - Blade - Lama
Cuchilla - Lâmina - Plaatje

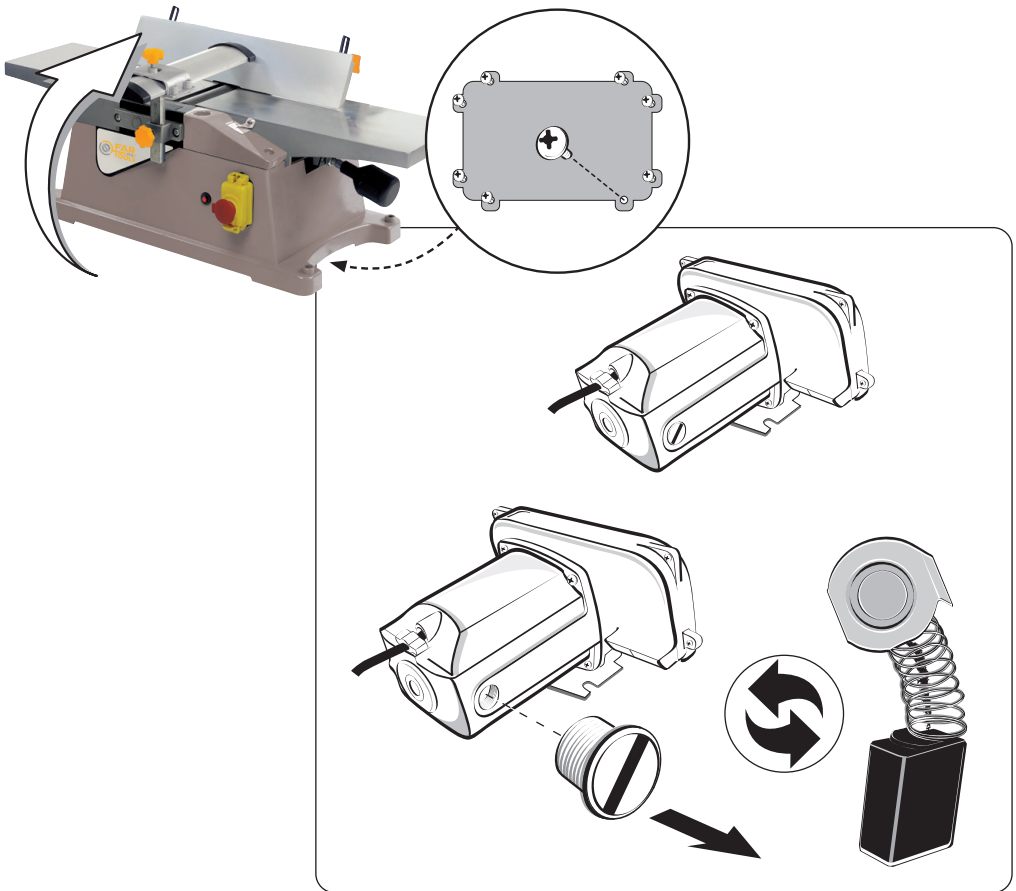
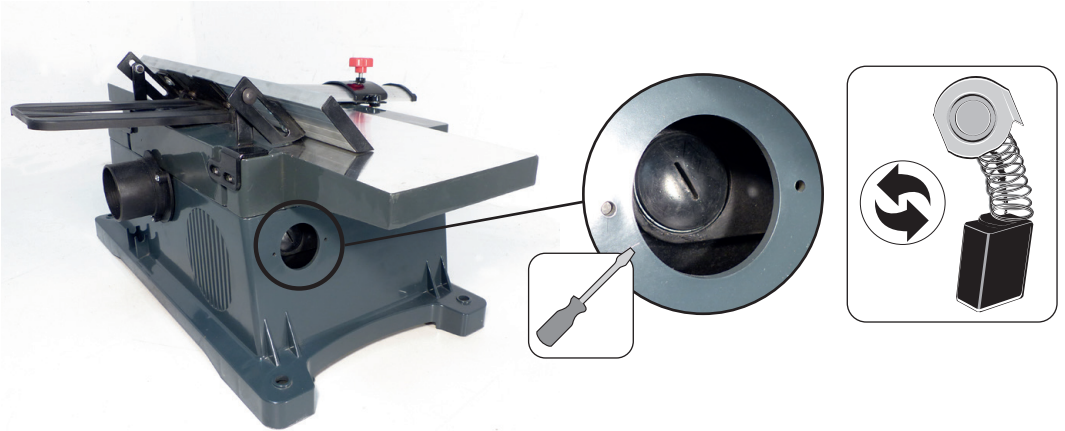







	<p>Tension et fréquence assignée: Nominal frequency and power: Nennspannung und Nennfrequenz : Tensión y frecuencia fijada: Tensione e frequenza assegnata: Tensão e frequência fixa: Aangewezen spanning en frequentie: ΟΝΟΜΑΣΤΙΚΗ ΤΑΣΗ ΚΑΙ ΣΥΧΝΟΤΗΤΑ: Napięcie i częstotliwość przydzielona: Jännite ja määrittäty taajuus: Angiven spänning och frekvens: Anført spænding og frekvens: Tensiune și frecvență de lucru:</p>	<p>Заданное напряжение и частота: Tahsis gerilimi ve frekansı: Stanovené napětí a frekvence: Stanovené napätie a frekvencia: Merkespenning og merkefrekvens: الغليظة والذبذبة الجبرمجة. Névleges feszültség és frekvencia: Napetost in določena frekvenca: Консумирано напрежение и честота : Määratud pinge ja sagedus Nustatytą įtampą ir dažnįs Noteiktais spriegums un frekvence. Napon i nazivna frekvencija:</p>	<p>230 V ~ 50 Hz</p>
	<p>Puissance assignée: Nominal power: Nennleistung: Potencia fijada: Potenza assegnata: Potência assinada: ΟΝΟΜΑΣΤΙΚΗ ΙΣΧΥΣ: Prędkość na biegu jałowym: Teho: Angiven effekt: Anført styrke: Putere de lucru:</p>	<p>Заданная мощность: Tahsis edilen güç: Stanovený výkon: Predpísaný výkon: Merkeeffekt: القدرة الجبرمجة. Névleges teljesítmény : Določena jakost: Консумирана мощност: Määratud võimsus. Nustatytą galia Noteiktā jauda Nazivna snaga:</p>	<p>1800 W</p>
	<p>Vitesse à vide: No-load speed: Leerlaufdrehzahl: Velocidad vacía: Velocità a vuoto: Velocidade no vácuo: Leerlaufdrehzahl: ΤΑΧΥΤΗΤΑ ΑΔΡΑΝΕΙΑΣ: Prędkość bez bciążenia: Tyhjäkäyntinopeus Tomgångshastighet: Hastighed i ubelastet tilstand: Viteza în gol:</p>	<p>Скорость вращения на холостом ходу: Boşalma hızı: Rychlost naprázdno: Rýchlosť pri chode naprázdno: Tomgångshastighet: السرعة على الفارغ. Üres sebesség: Prosti tek: Скорост на празни обороти: Kiirus tühikäigul Tušćio prietaiso greitis Tukšgaitas ātrums Brzina praznog hoda:</p>	<p>12000 min⁻¹</p>
	<p>Dimensions table : Dimensions of table : Tischabmessungen : Dimensiones mesa : Dimensioni tabella : Dimensões da mesa : Afmetingen tafel : ΔΙΑΣΤΑΣΕΙΣ ΤΡΑΠΕΖΙΟΥ : Wymiary stołu : Mittapöytä : Bordets storlek : Bordets mål : Dimensiuni masă :</p>	<p>Размеры стола : Tablo boyutu : Rozměr stolu : Rozmery dosky : מידת שולחן أبعاد الطاولة Az asztal mérete: Dimenzije ventilatorja: Размери на плота : Ketta suurus : Stovo matmenys : Galda izmēri : Dimenzije stola:</p>	<p>360 x 155 mm (x2)</p>

		0 - 3 mm
---	--	----------

	90° : 0-155 mm 45° : 0-100 mm	155 mm
---	----------------------------------	--------

	<p> Classe d'isolement : 2 Insulation class : 2 Isolierklasse : 2 Aislamiento clase :2 Isolamento classe :2 Isolamento classe :2 Isolatīe Klasse : 2 ΚΑΤΗΓΟΡΙΑ ΜΟΝΩΣΗΣ: 2 Izolacija Klazy :2 Eristysluokka :2 Isolering Klass :2 Isoleringssklasse 2 Clasă izolație :2 </p> <p> Класс изоляции 2 : Yalitim derecesi :2 Třída izolace :2 Izolačný systém 2 Isolasjonsklasse: 2 فئة العزل :2 Szigetelési osztály :2 Razred izolacije :2 Инструмент Клас :2 Isolatsiooniklass 2 Izolācijas rūšis 2 Izolācijas klase 2 Izolacija klasa: 2 </p>	X
---	--	---

		154,5 x 16,5 x 1,8 mm
---	--	-----------------------

 L_{pA}	Niveau de pression acoustique : Acoustic pressure level : Schalldruckpegel : Nível de presión acústica : Livello di pressione acustica : Nível de pressão acústica : Niveau akoestische druk : ΣΤΑΘΜΗ ΗΧΗΤΙΚΗΣ ΠΙΕΣΗΣ: Poziom mocy akustycznej : Käytä kuulosuojaimia: Ljudtrycksnivå : Lydtryk : Nível presiune acustică :	Уровень акустического давления. : Akustik basınç seviyesi : Hladina akustického tlaku : Hladina akustického tlaku : Lydtrykknivå: مستوى الضغط السمعي. A hangnyomás szintje : Nivo akustičnega pritiska: Равнище на акустично налягане : Helirõhu tase Akustinio spaudimo lygis Akustiskā spiediena līmenis Razina zvučnog tlaka:	99,7 dB (A)

 L_{wA}	Niveau de puissance acoustique : Acoustic power level : Schalleistungspegel : Nível de potencia acústica : Livello di potenza acustica: Nível de potência acústica: Niveau akoestisch vermogen : ΕΠΙΠΕΔΟ ΙΣΧΥΟΣ ΗΧΟΥ: Poziom mocy akustycznej : Käytä suojalaseja : Ljudstyrkenivå : Lydstyrke : Nível putere acustică :	уровень мощности звука : Akustik basınç seviyesi : Hladina zvukového výkonu: Hladina zvukového výkonu: Lydeffektnivå: مستوى الصوتي. a hangnyomás szintje : Nivo akustične jakosti : Равнище на вибрации : Helivõimsuse tase Triukšmo lygis Akustiskās jaudas līmenis Razina zvučne snage:	114,2 dB (A)

NIVEAU SONORE D'ÉMISSION :

A VIDE

Pression acoustique L_{pA} poste opérateur
Incertitude

99,7 dB
3

Puissance acoustique L_{wA}
Incertitude

114,2 dB
3

Valeurs déterminées suivant le code d'essai de l'annexe B de la norme EN 61029-1 avec emploi des normes de base ISO 11201 et ISO 3744.

Les niveaux de pression acoustique obtenus in situ dépendent:

- Des niveaux réels de la machine considérées, en prenant en compte les incertitudes déclarées;
- Du local et de l'installation de la machine. Préférez une pièce dont l'acoustique est plus feutrée. Evitez les pièces vides à grande résonance. Placez vous auprès d'une fenêtre le cas échéant.
- Des outils montés, des pièces travaillées, des réglages choisis,...

	Niveau de vibration : Hand/arm vibration level : Vibrationspegel Hand/Arm : Nível de vibración mano/brazo : Livello di vibrazione mano/braccio : Nível de vibração mão/braço : Trillingsniveau hand/arm : ΕΠΙΠΕΔΟ ΚΡΑΔΑΣΜΩΝ: Poziom vibracji rżka/ramiż : Tärinätaso: Vibrationsnivå hand/arm : Vibrationsniveau : Nível vibrații :	Уровень вибрации : Titreşim seviyesi : Úroveň vibrací : Hladina vibrácií : Vibrasjonsnivå: مستوى الارتجاج. Vibrációsintzint : Nivo vibracij : Равнище : Vibrācijas līmenis. Vibracijos lygis Vibratsiooni nivo Razina vibracije:	2,6 m / s ²

VIBRATIONS:

Total des valeurs de vibration (somme vectorielle des trois directions) déterminée selon EN 60745 :

a
Incertitude K

2,6 m/s²
1,5 m/s²

L'amplitude d'oscillation peut être utilisée comme valeur de comparaison d'outils électroportatifs.

Attention : si l'outil électroportatif est utilisé pour d'autres applications, avec d'autres outils de travail, l'amplitude d'oscillation peut être différente.

	<p>Lire les instructions avant usage : Read the instructions before use : Vor Einsatz des Geräts Anweisung lesen : Léase las instrucciones antes de usar : Leggere le istruzioni prima dell'uso : Ler as instruções antes da utilização : Lees voor het gebruik de instructies : ΔΙΑΒΑΣΤΕ ΤΙΣ ΟΔΗΓΙΕΣ ΠΡΙΝ ΑΠΟ ΤΗ ΧΡΗΣΗ: Zapoznać się instrukcją przed użyciem : Lue ohjeet ennen käyttöä : Läs anvisningarna före användning : læs instruktionerne før brug Înainte de utilizare, cititi instructiunile :</p>	<p>Внимательно прочитайте следующие инструкции : Kullanmadan talimatları okuyunuz : Pozorně si přečtete následující pokyny : Pred použitím si prečítajte pokyny : Les bruksanvisningen før bruk: اقرأ التعليمات قبل الاستخدام. használat előtt olvassuk el az utasítást : Pred uporabo preberite ustrezna navodila Прочетете указанията за употреба : Enne kasutamist lugege instruksiooni Prieš naudojimą perskaityti instrukciją izlasīt instrukcijas pirms lietošanas Pročitati upute prije uporabe:</p>	X
---	--	---	---

	<p>Conformité européenne Conforms to EC standards : CE-Konformität : Cumple con las directivas CE : Conforme alle norme CE : Conforme às normas CE : Voldoet aan de EG-normen : ΕΥΡΩΠΑΪΚΗ ΣΥΜΜΟΡΦΩΣΗ Zgodność z normami CE : EU-standardien mukainen : EU-standardien mukainen : Overholder EU standarderne : Conform cu normele europene:</p>	<p>соответствие европейским стандартам: Avrupa uygunluk : evropská shoda : európska dohoda : Europeisk konformitet مطابق للمواصفات الأوروبية. evropska ustreznost : európai megfeleléség : Съответствие с европейските норми : Euroopa liidu vastavusmärk Europinių normų atitikima Atbilstība Eiropas standartiem Europska sukladnost</p>	X
---	--	--	---

	<p>Danger : Danger : Gefahr : Peligro : Pericolo : Perigo : Gevaar : ΚΙΝΔΥΝΟΣ: Niebezpieczeństwo : Vaara : Fara : Fare : Pericol :</p>	<p>Опасно : Tehlike : Nebezpečí : Nebezpečnost : Fare: خطر. Veszély : Nevarnost: Опасност : Oht Pavojus Bistamība Opasnost:</p>	X
--	--	---	---

	<p>Poids : Weight : Gewicht : Peso : Peso : Peso : Gewicht : ΒΑΡΟΣ : Masa : Paino : Vikt : Vægt : Greutate :</p>	<p>Бес : Ağırlık : Hmotnost : Hmotnosť : Vekt: الوزن. Súly : Teža : Terho : Raskus Svoris Svarts Težina</p>	8,5 kg
---	--	---	--------

	<p>Porter des lunettes de sécurité : Wear protective eyewear : Schutzbrille tragen : Llevar puestas gafas protectoras : Portare de gli occhiali di sicurezza : Utilizar óculos de segurança : Draag een veiligheidsbril : ΦΟΡΑΤΕ ΠΡΟΣΤΑΤΕΥΤΙΚΑ ΓΥΑΛΙΑ: Zakładać okulary ochronne : Käytä suojalaseja : Använd skyddsglasögon : Der skal benyttes sikkerhedsbriller : Purtati ochelari de protectie :</p>	<p>Наденьте защитные очки : Güvenlik gözlükleri takın : Používejte bezpečnostní brýle : Noste ochranné okuliare : Bruk vernebriller: حامل نظارات وقاية. Viseljen védőszemüveget : Nositi zaščitna očala : Да се използват защитни очила : Kandke kaitseprille Nešioti apsauginius akinius Valkät aizsargbrilles Nositi zaštitne naočale:</p>	×
---	--	--	---

	<p>Porter un masque anti-poussière : Wear a dust mask : Staubschutzmaske tragen : Llevar puesta una careta de protección contra el polvo : Indossare una mascherina anti-polvere : Utilizar uma máscara anti-poeira : Draag een stofmasker : ΦΟΡΕΣΤΕ ΜΑΣΚΑ ΓΙΑ ΤΗ ΣΚΟΝΗ: Zakładać maskę przeciwpylową Käytä pölysuojust : Bär mask mot damm : Der skal benyttes beskyttelsesmaske mod støv: Purtati mască anti-praf :</p>	<p>Наденьте респиратор : Toza karşı maske takın : Používejte masku proti prachu : Noste ochrannú masku proti prachu : Bruk en støvmaske: لبس قناع مضاد للتلوث. Viseljen porvédő maszkot Nositi zaščitno masko proti prahu: Да се използва защитна маска : Kandke tolmumaski. Dėvėti respiratorių Valkät aizsarg masku pret putekljem Nositi masku za zaštitu od prašine:</p>	×
---	---	--	---

	<p>Porter une protection auditive : Wear hearing protective equipment: Gehörschutz tragen: Llevar puesta una protección auditiva: Portare una protezione uditiva: Utilizar uma protecção auditiva: Draag gehoorbeschermers: ΦΟΡΑΤΕ ΠΡΟΣΤΑΣΙΑ ΑΚΟΗΣ: Zakładać słuchawki ochronne Käytä kuulusoajimia: Bär hörselskydd: Der skal benyttes høreværn: Purtati căști de protecție auz:</p>	<p>наденьте средства звуковой защиты: İşitsel koruma aleti takın: Používejte ochranu sluchu: Noste ochranné slúchadlá: Bruk hørselsvern: لبس عوذة خضض الخرجي Viseljen fülvédőt Nositi zašito ušes: Да се използват слухови защитни средства: Kandke kōrvakaitset Nešioti apsaugą nuo triukšmo Valkät dzirdes aizsarglīdzekli Nositi štítnike protiv buke:</p>	×
---	---	---	---

	<p>Porter des gants : Use rubber gloves : Scchutzhandschuhe tragen : Llevar guantes de protección : Indossare i guanti di protezione : Utilizar luvas de protecção : Draag veiligheidshandschoenen : ΦΟΡΩΝΤΑΣ ΓΑΝΤΙΑ: Używać rękawic ochronnych : Käytä suojakäsineitä : Använd skyddshandskar : Der skal benyttes handsker : Purtati mănuși :</p>	<p>Наденьте перчатки : Eldiven takın : Noste rukavice : Noste rukavice : Bruk hansker: لبس قفازات. Viseljen kesztyű t Nositi rokavice: а се използват предпазни ръкавици : Kandke kindaid Mūvēti pirštines Valkät cimds Nositi zaštitne rukavice:</p>	×
---	--	---	---

	<p>Soumis à recyclage Subjected to recycling Sujeto a reciclaje Sottoposti a riciclaggio Sujeitos à reciclagem Não deite no lixo : Niet wegwerpen : ΥΠΟΚΕΙΤΑΙ ΣΕ ΑΝΑΚΥΚΛΩΣΗ Nie wyrzucac : Älä heittää pois luontoon : Batteriet får inte kastas : Bortkast det ikke: Nu le auncati :</p>	<p>Подлежит переработке Atmayiniz : Nevyhadzujte je do bežného odpadu : Neodhadzovat : Gjenvinningspliktig فلا ترمدها لهذا في القمامة. ne mečíte1 Ne odvržite ga/jih vstran : Taaskasutusse kuuluv Ärge visake seda minema : Nemétykite : Nemest : Podvrgnuto recikliranju</p>	×
---	---	--	---

Recyclage des déchets :

Les outils, accessoires et leur emballages doivent suivre une voie de recyclage adaptée. Conformément aux directives Européenne 2012/19/UE et 2006/66/CE, les composants d'un produit doivent être séparés, collectés, recyclés ou éliminés en conformité avec les réglementations environnementales en vigueur. Les appareils, batteries, piles, huiles, emballages devront être déposés dans les systèmes d'élimination des déchets spéciaux tels que déchetteries. Renseignez-vous auprès de votre commune pour connaître l'organisme le plus proche à même de retraiter ou de collecter ces déchets.

	<p>Recyclable, soumis au tri sélectif Recyclable, subject to recycling Recyclingfähige, unterliegen Recycling Reciclables, sujetos a reciclaje Riciclabili, soggetti a riciclaggio Recicláveis, sujeito à reciclagem Recycleerbare, onderworpen aan recycling ΑΝΑΚΥΚΛΩΣΙΜΟ, ΥΠΟΚΕΙΤΑΙ ΣΕ ΕΠΙΛΕΚΤΙΚΗ ΔΙΑΛΟΓΗ Opakowanie nadaje się do recyklingu podlegają recyklingu Kierrätettävien pakkausten kohteena kierrätys Återvinningsbara förpackningar omfattas återvinning Рециклиращи се опаковки подлежат на рециклиране Genanvendelig underlagt genbrug</p>	<p>Reciclabile sub rezerva reciclare Повторно упаковка подлежит вторичной переработке Geri dönüŝüm Geri dönüŝtürülebilir ambalaj konusu Recyklovateľné podležajúci recyklaci Recyklovateľné podliehajúce recyklácii Resirkulerbar, med förbehold om selektiv sortering ريودنلا فادال يضرئت ريودنلا فادال فليانلا فليانلا و قوب عتلا Újrahasznosítható csomagolás alá újrahasznosítás Reciklirati predmet recikliranje Pakendite suhtes ringlussevõtu Pärsträdajams iepakojuoms otrreizējai pārstrādei Perdirbamų taikomos perdirbimo Može se reciklirati, podložno selektivnom sortiranju</p>	×
---	--	---	---

RB 1800D

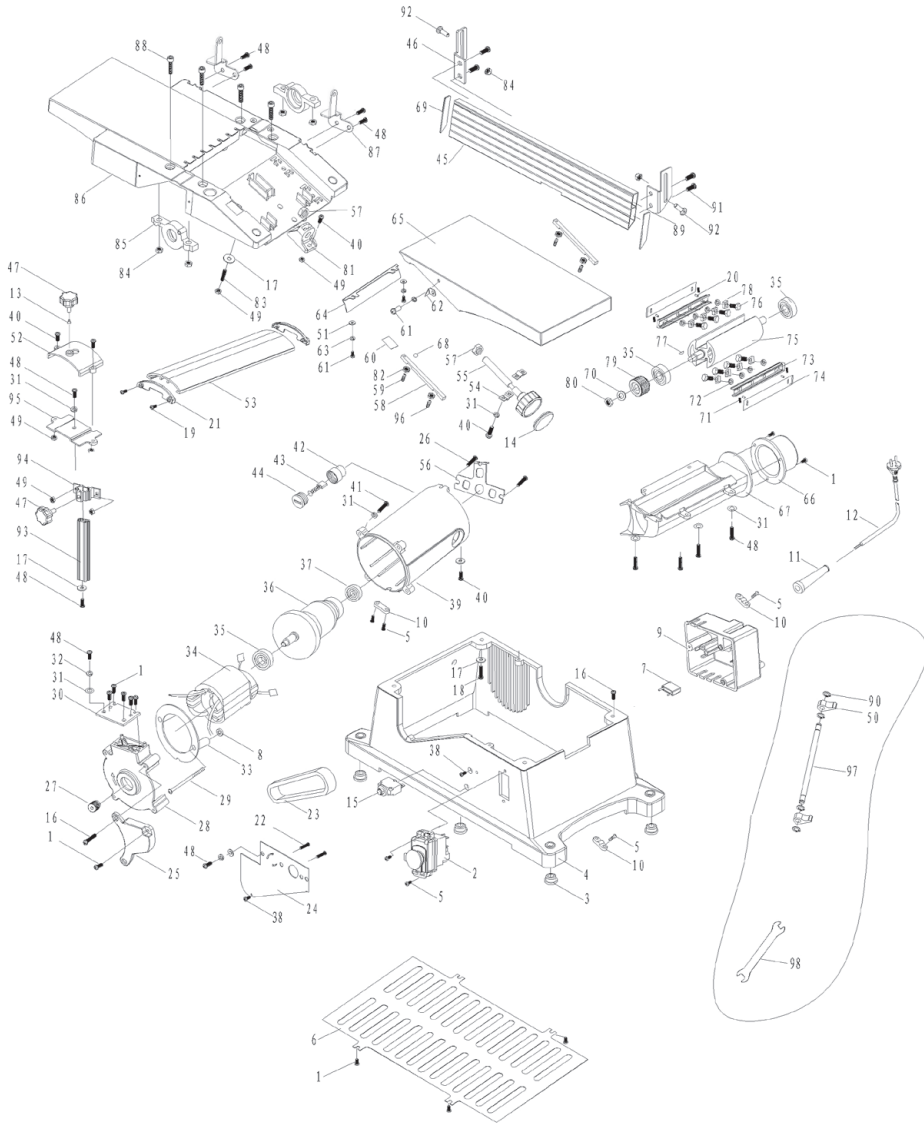

DECLARATION DE CONFORMITE
 VERKLARING VAN OVEREENSTEMMING
 DECLARACION DE CONFORMIDAD
 DICHIARAZIONE DI CONFORMITA
 KONFORMITÄSERKLÄRUNG
 DECLARATION CONFORMITY
 DECLARAÇÃO DE CONFORMIDADE
 DEKLARACJA ZGODNOSCI Z NORMAMI
 OM ÖVERENSSTÄMMELSE
 VAATMUSTENMUKAISUUSVAKUUTUS
 ÖVERENSSTEMMELSESERKLÄRING
 Δήλωση συμμόρφωσης/συμμόρφωση

DECLARAȚIE DE CONFORMITATE
 VYHLÁSENIE ZHODY
 Декларация соответствия
 הצהרת תואמת
 Uygunluk beyanı
 التصريح بالخطابفة
 PROHLÁŠENÍ SHODY
 EGYZESÉGI NYILATKOZAT
 Декларация за съответствие с нормите
 IZJAVA O SKLADNOSTI
 DEKLARACIJA
 ΑΠΗΚΤΙΕΣ ΔΕΚΛΑΡΑCΙΑ
 KINNITTUS
 IZJAVA O SUKLADNOSTI

Le soussigné,
 Ondergetekende,
 Der Unterzeichner,
 O abaixo assinado,
 Undertecknad,
 Долуподписаният
 Undertegnede
 Subsemnatul,
 Я, нижеподписавшийся,
 Imzalayan,
 Níže podepsaný,
 Toliau pasirašęs

Déclare par la présente que,
 Verklaart hiermede dat,
 Erklärt hiermit daß,
 Declara pela presente que,
 Förklarar härmed att
 Заявляя с настоящото
 erklærer hermed, at
 Declar prin prezenta că,
 настоящим подтверждаю, что
 Mecvut belgeyle beyan ediliyor ki,
 timto prohlášeje, že,
 Pareiškia, kad,

Personne autorisée à constituer
 le dossier technique :
 Ronan GUILLIOT



FAR GROUP EUROPE
 192, Avenue Yves Farge
 37700 St. Pierre-des-Corps
 FRANCE

El suscrito,
 Il sottoscritto,
 The undersigned,
 Nínej podpisany
 Allekirjoittanut,
 Ουπτογεγραμμένος
 Nižšie podpísaný
 המחתום הט
 الحقوق أدناه
 Alulírott,
 Podpisani,
 Apakšā parakstīties
 allakirjutanu
 Dolje potpisani,

Declara por la presente, que,
 Dichiare che,
 Declares that,
 Oöviadcaz na miejszym, że
 Ilmoitetaan täten että,
 Δηλώνει με την Παράστα
 týmto vyhlasuje, že
 מצהיר בה כי
 يصرح استنادا على ذلك
 kijelentem, hogy a Készülék Izjavlja da,
 Pareiškia, kad,
 Ar šo apliecina, ka,
 Kinnitab, et
 Izjavljuje u ovom dokumentu da je

Dégauchisseuse / Jointer / Elektrohobel / Pialla elettrica / Pialla a filo / Máquina de Aplinar / Elektrische Schaafmachine /
 Hlektrikβ Πλάνη / Strugarka Elektryczna / sähköhöylä / elhyvel / Электрическо ренде. / Elektrisk høvl / Rindea electrică /
 Электрический строг / Elektrikli rende / Elektrický hoblík / Elektrický hoblík / תלכושח תעצקמ / تجي.أبرهك رتيم / Elektromos gyalu
 / Električni oblič / Freesimispink / Stacionārā ēvele / Stacionarus oblius

code

FARTOOLS / 113395 / RB 1800D / M1B-LS-1558

Est conforme et satisfait aux directives et normes CE,
 In overeenstemming is met en Voldoet aan EG richtlijnen,
 Den følgende EU-Bestimmungen entspricht,
 Respeita e está em conformidade com as normas CE,
 Överensstämmer med och uppfyller EG-standarder,
 Съответства и отговаря европейските норми
 Er i overensstemmelse med og overholder EU standarderne
 Este conform și satisfase normele CE
 полностью соответствует и удовлетворяет
 требованиям стандартов EC
 CE şartlara uygundur,
 odpovídá normám ES.
 Atitinka ir atitinka EB direktyvas ir standartus,

Cumple con la directivas de la CE,
 E conforme alle direttive CEE,
 Complies with the EEC directives and standards,
 Odpowiada normom UE,
 Täyttää EU-vaatimukset,
 Είναι συμμόρφωσο και ανταΠοκρίνεται στα Πρωτόλλα CE
 zodpovedá normám ES.
 CE מתאיים ועונה לתקני CE
 بان الرجهاز يطابق و يجلي معايير مجموعة الدول الأوروبية
 kielęgiti a CE szabványok előírásait.
 Je v skladu z in izpolnjuje norme Evropske skupnosti.
 Atbilst un atbilst EK direktīvas un standartus,
 Vastab ja vastab EÜ direktiividele ja standarditele,
 Sukladan i ispunjava direktive i standarde CE,

Attestation de type (EC type) N° BM50330730001

TUV Rheinland LGA Products GmbH - Tillystraße 2 - 90431 Nürnberg
 Accredited by Zentralstelle der Länder für Sicherheitstechnik (ZLS).
 Notified under No. 0197 to the EC Commission.

Rapport (report) N° 14717618003

2014/30/EU 2006/42/EC 2011/65/EU 2015/863/EU

EN 61029-1 : 2009 + A11
 EN 61029-2-3 : 2011
 EN 55014-1 : 2017
 EN 55014-2 : 2015
 EN IEC 61000-3-2 : 2019
 EN 61000-3-11 : 2000

Ronan GUILLIOT,
 Directeur général
 10/01/2022
 Fait à St. Pierre-des-Corps





FR. GARANTIE

Cet outil est garanti contractuellement contre tout vice de construction et de matière, à compter de la date de vente à l'utilisateur et sur simple présentation du ticket de caisse. La garantie consiste à remplacer les parties défectueuses. Cette garantie n'est pas applicable en cas d'exploitation non conforme aux normes de l'appareil, ni en cas de dommages causés par des interventions non autorisées ou par négligence de la part de l'acheteur. La garantie ne s'applique pas sur les dommages causés par une défaillance de l'outil.

DE. GARANTIE

Die Garantiezeit für dieses Gerät in bezug auf Konstruktions- und Materialfehler beträgt lt. Vertrag bei Vorlage des Kassensbons. Die Garantieleistung besteht im Ersatz schadhafter Teile. Die Garantie erlischt bei einem Einsatz des Geräts, der nicht normentsprechend ist, bei Schäden, die auf unsachgemäße Eingriffe zurückzuführen sind bzw. bei Nachlässigkeit seitens des Käufers. Die Garantie erstreckt sich nicht auf Schäden, die auf Fehlfunktionen des Geräts zurückzuführen sind.

IT. GARANTIA

Quest' attrezzo è garantito per contratto contro qualsiasi difetto di costruzione e di materia, a partire dalla data di vendita all' utente e su semplice presentazione dello scontrino. La garanzia consiste nel sostituire le parti difettose. Questa garanzia non è applicabile in caso di sfruttamento non conforme alle norme dell' apparecchio, né in caso di danni causati da interventi non autorizzati o da negligenza da parte dell' acquirente. La garanzia non si applica ai danni causati da un avaria dell' attrezzo.

EN. GARANTIE

This tool is guaranteed, in writing, against any defect in manufacture of parts from the date of sale, upon simple presentation of the sales slip. The guarantee is limited to the replacement of faulty parts. This guarantee is not applicable in the event of usage which is not conform with the intended usage of the apparatus, nor in the event of damage caused by unauthorised servicing or negligence on behalf of the purchaser. This guarantee does not apply to any damage caused by

the failure of this tool.

ES. GARANTIA

Esta herramienta se garantiza contractualmente contra todo defecto de construcción y materia, a partir de la fecha de venta a l' usuario y sobre simple presentación del recibo de caja. La garantía consiste en sustituir a las partes defectuosas. Esta garantía no es aplicable en caso de explotación no conforme a las normas del aparato, ni en caso de danos causados por intervenciones no autorizadas o por negligencia por parte del comprador. La garantía no se aplica sobre los danos causados por un fallo del herramienta.

NL. GARANTIE

Dit gereedschap heeft een garantie tegen constructiefouten en materiaaldefecten, die geldig is vanaf de aankoopdatum door de gebruiker, op vertoning van de kassabon. De garantie betreft de vervanging van de defecte onderdelen. Deze garantie is niet van toepassing indien het apparaat niet volgens de normen gebruikt is, noch in geval van schade veroorzaakt door oneigenlijk gebruik of nalatigheid van de koper. De garantie is niet van toepassing op schade voortvloeiend uit een defect van het gereedschap.

PT. GARANTIA

Esta ferramenta tem uma garantia contratual contra qualquer defeito de construção e de material, a partir da data de venda ao utilizador e sobre simples apresentação do talão da caixa. A garantia consiste em substituir as partes defeituosas. Esta garantia não é aplicável no caso de exploração não conforme as normas do aparelho, nem em caso de danos causados pelas intervenções não autorizadas ou por negligência da parte do comprador. A garantia não se aplica para os danos causados por uma falha da ferramenta.

EL. ΓΑΡΑΝΤΙΑ

ΑΥΤΟ ΤΟ ΕΡΓΑΛΕΙΟ ΕΙΝΑΙ ΣΥΜΒΑΤΙΚΑ ΕΓΓΥΗΜΕΝΟ ΓΙΑ ΟΠΟΙΟΔΗΠΟΤΕ ΚΑΤΑΣΚΕΥΑΣΤΙΚΟ ΚΑΙ ΥΛΙΚΟ ΕΛΑΤΤΩΜΑ, ΑΠΟ ΤΗΝ ΗΜΕΡΟΜΗΝΙΑ ΠΩΛΗΣΗΣ ΣΤΟΝ ΧΡΗΣΤΗ ΚΑΙ ΜΕ ΤΗΝ ΕΠΙΔΕΙΞΗ ΤΗΣ ΑΠΟΔΕΙΞΗΣ ΠΩΛΗΣΗΣ. Η ΕΓΓΥΗΗ ΣΥΝΙΣΤΑΤΑΙ ΣΤΗΝ ΑΝΤΙΚΑΤΑΣΤΑΣΗ ΤΩΝ ΕΛΑΤΤΩΜΑΤΙΚΩΝ ΕΞΑΡΤΗΜΑΤΩΝ. ΑΥΤΗ Η ΕΓΓΥΗΗ ΔΕΝ ΙΣΧΥΕΙ ΣΕ ΠΕΡΙΠΤΩΣΗ ΛΕΙΤΟΥΡΓΙΑΣ ΠΟΥ ΔΕΝ ΣΥΜΜΟΡΦΩΝΕΤΑΙ ΜΕ ΤΑ ΠΡΟΤΥΠΑ ΤΗΣ ΣΥΣΚΕΥΗΣ, ΟΥΤΕ ΣΕ ΠΕΡΙΠΤΩΣΗ ΖΗΜΙΑΣ ΠΟΥ ΠΡΟΚΑΛΕΙΤΑΙ ΑΠΟ ΜΗ ΕΠΕΘΥΣΙΟΔΟΤΗΜΕΝΕΣ ΕΠΕΜΒΑΣΕΙΣ Ή ΑΜΕΛΕΙΑ ΚΑΙ ΜΕΡΟΥΣ ΤΟΥ ΑΓΟΡΑΣΤΗ. Η ΕΓΓΥΗΗ ΔΕΝ ΙΣΧΥΕΙ ΓΙΑ ΖΗΜΙΕΣ ΠΟΥ ΠΡΟΚΑΛΟΥΝΤΑΙ ΑΠΟ ΑΣΤΟΧΙΑ ΕΡΓΑΛΕΙΟΥ.

PL. GWARANCJA

Narz dzie jest objte gwarancja na wszelkie wady konstrukcyjne i materiałowe, licząc od daty

sprzedaży u użytkownikowi i po okazaniu paragonu kasowego. Gwarancja obejmuje wymianę cz.ści wybrakowanych. Gwarancja nie znajduje zastosowania w przypadku u.ýtowania niezgodnego z normami urzadzzenia, ani w przypadku szkod spowodowanych działaniami niedozwolonymi lub zaniedbaniami ze strony nabywcy. Gwarancja nie obejmuje szkod powstałych z powodu upadku urzadzzenia.

SV. GARANTI

Detta verktyg har en avtalsenlig garanti mot konstruktions och materialfel, från och med tidpunkten för användarens inköp och genom uppvisning av kassakvittot. Garantin består i att ersätta de bristfälliga delarna. Denna garanti gäller inte om användningen inte motsvarar apparatens standarder, inte heller vid skador som orsakas av ej tillåtna ingrepp eller på grund av köparens vårdslöshet. Garantin gäller inte förskador som orsakats av att verktyget fungerat bristfälligt.

FI. TAKUU

Tämän laitteen takuu on voimassa sopimusmukaisesti kattaen kaikki rakenne- ja materiaali- tai lukien ostopäivästä kassakuittia vastaan. Takuu sisältää viallisten osien korvaamisen. Takuu ei korvaa ohjeiden vastaista käyttöä eikä välttämättömyyden henkilöiden kasittelystä tai ostajan huolimattomuudesta aiheutuneita vahinkoja. Takuu ei vastaa myöskään toimintahäiriöistä aiheutuneita vahinkoja.

BU. ГАРАНЦИЯ

Този инструмент е под договорна гаранция срещу всякакъв дефект в изработката и използваните материали, считано от датата на продажба на потребителя и само срещу представяне на касовата бележка. Гаранционното обслужване се състои в замяна на дефектните части. Настоящата гаранция не е валидна когато апаратът се използва по начин, несъответстващ на стандарта за работа с него, както и в случай на щети, нанесени от неоторизирани лица, или вследствие на проявена небрежност от страна потребителя.

Гаранцията не покрива щети, произтекли вследствие на техническа неизправност на апарата.

DA. GARANTI

Dette værktøj er dækket af en garantikontrakt for konstruktions- og materialefejl, som gælder fra købsdatoen ved visning af kassebonen. Garantien består i at udskifte de defekte dele. Garantien dækker ikke fejl opstået som følge af anvendelse, som ikke overholder standarderne for apparatet, eller

SERVICE APRÈS VENTE - AFTER SALE SERVICE

FARGROUP EUROPE - 192, Avenue Yves Farge - 37700 St. Pierre-des-Corps - FRANCE
fargroup@fargroup.net



skader opstået ved ikke autoriserede indgreb eller sløsethed fra brugerens side. Garantien dækker ikke skader opstået, fordi værktøjet har svigtet.

RO. GARANTIE

Acest aparat este garantat din punct de vedere contractual împotriva tuturor viciilor de construcție și de material, începând de la data vânzării lui către utilizator și la simpla prezentare a bonului de casă. Garanția constă în înlocuirea componentelor defecte. Această garanție nu se aplică în cazul exploatării în alt mod decât cel recomandat de normele aparatului și nici în caz de stricăciuni provocate de intervenții neautorizate sau prin neglijența cumpărătorului. Garanția nu se aplică asupra pagubelor cauzate de o defectare a aparatului.

RU. ГАРАНТИЯ

Данное изделие обладает определенной силой контракта гарантии, покрывающей все возможные дефекты изготовления и материала. Гарантия вступает в силу с даты продажи изделия пользователю, для этого достаточно сохранить и предъявить полученный в кассе чек. Гарантия обязывает изготовителя заменить дефектные части изделия. В случае не соответствующего нормам использования изделия, несанкционированного демонтажа или ремонта или небрежного обращения действие гарантии прекращается. Гарантия не покрывает ущерба, возникшего в результате сбоев в работе изделия.

TU. GARANTI

Bu arac, satis tarihinden itibaren, kullanicinin sadece vezne alindisini sunmasyyla tum uretim ve malzeme hatasina karsi garantidir. Garanti eksik olan kisimlari degistirmek icindir. Bu garanti aracin sartlarina uygun olmayan isleme durumunda, izin verilmeveyen kullanilardan kaynaklanan hasarlarda veya alicinin istegi durumunda uygulanmaz. Garanti malzemenin bir eksikliginden meydana gelen bir zararda uygulanmaz.

CS. ZÁRUKA

Pro tento nástroj platí smluvní záruka na všechny výrobní a materiálové vady od data prodeje uživateli a na základě předložení pokladního bloku. Záruka spočívá ve výměně vadných částí. Tato záruka neplatí v případě použití přístroje, které

neodpovídá normám, ani v případě škod způsobených nepovolenými zásahy nebo nedbalostí ze strany kupujícího. Záruka se nevztahuje na škody způsobené zavádou nástroje.

SK. ZÁRUKA

Pre tento nástroj platí zmluvná záruka na všetky výrobné a materiálové chyby od dátumu predaja užívateľovi a na základe predloženia pokladničného bloku. Záruka spočíva vo výmene chybných častí. Táto záruka neplatí v prípade použitia prístroja, ktoré nezodpovedá normám, ani v prípade škod spôsobených nepovolenými zásahmi alebo nedbalosťou zo strany kupujúceho. Záruka sa nevztahuje na škody spôsobené poruchou nástroja

AR. الضمان

في لغتي ءارشلاقطاب ميديقت درجم بلع ءانبو بعنسملا بلا عيلا خيرات نم ارايعنا ،اواملايفوق ينصتلا يف بيع نا نم ايداعنا قنومضم دد علا هذه نا ،تافاللتال هضرعت ءلاخف الو ،زاهجلا زيناعمل قناملار ربع مارتحسلا ءلاخ يف قنيطتل الباق نامضلا انه نوكي ال ءلطاعلا ءازجالا لاديسن ياف نامضلا للتح كم جتاننار رضلا بلع نامضلا قنيطني ال يرشمتلا ليق نم لامهالا ءلاخ يف وا فصرنوم ربع لحدث تابلعم نع مجتان

HU. GARANCIA

Erre a szerszámra szerződéses garanciát vállalunk bármilyen gyártási es anyagi hibára felmerülő esetre, a fogvasztó részére történt eladás napjától számítva, a penztári blokk egyszerű felmutatása elleneben. A garancia a hibás alkatrészek cseréjére terjed ki. Ez a garancia nem érvényes, ha a készleket nem rendelteszserűen használták, sem illetéktelen beavatkozások vagy a vásárló hanyagsága okozta károk eseten. A garancia nem fedezi azokat a károkat, melyeket a szerszám hibás működése okozott.

SI. GARANCIJA

To orodje je z garancijsko pogodbo zašciteno proti vsem napakam v izdelavi in v sestavnem materialu od datuma prodaje naprej in ta velja ob predložitvi blagajniškega racuna . Garancija velja za zamenjavo delov z napako. Ta garancija ne velja za uporabo orodja, ki nj v skladu z normami, predpisanimi za omejeno orodje in za primere okvar, ki nastanejo zaradi nedovoljenih posegov na orodju ali zaradi malomarnega rokovanja kupca. Garancija ne velja za škodo, ki jo lahko povzroci okvara orodja.

ET. GARANTII

See tooriist kuulub lepingu järgi garantiiremonti arvestades alates müumise päevast ja kassatseki alusel kasutajale koigi konstruktsiooni- ja materjali vigade puhul. Garantii seisneb defektsete osade välja-

vahetamises. See garantii ei kehti aparaadi normide ebatavalise eiramise puhul ega ostja poolt keelatud viisil kasutamisesest või hooletussejätmisest tulenevate kahjude korral. Garantii ei kehti seadme defektidest põhjustatud kahjude puhul

LV. GARANTIJA

Sis prietaisās yra uztikrinamas kaip itin geros kokybės, nuo jo pardavimo datos iki jo panaudojimo, ir jam yra suteikiamas garantinis taloņas. Garantijos metu galima pakeisti atsiradusius trumplataikius gedimus. Si garantija netaikoma esant netinkamam naudojimui ar nesilaikant reikiam šio aparato vartojimo instrukcijų, tai pat paciam virkejui jį sugadinus. Garantija taip pat netaikoma, prietaisa naudojant ne pagal paskirti ir jį apgadinus

LT. GARANTIJA

Sim darbarikam ir liguma noteikta garantija visiem defektuim, kas saistās ar konstrukciju un materialu, sakot ar pardosanas datumu, kad masinu pardod lietotajam un vienkarsi uzradot kases ceku. Garantija ieklauj bojato dalu nomainu. Si garantija nav deriga, ja aparats nav lietoats saskana ar drošibas noteikumiem, ne gadijums ja bojajumi radusies nesankcionetas ,tejauskasas gadijuma vai ar pierceja nolaidibas del. Garantija nav deriga, ja bojajumi radusies darbarika defekta del

HR. JAMSTVO

Ovaj alat ima ugovorno jamstvo u slucaju bilo kakvih nedostataka u konstrukciji i materijalu, od datuma prodaje korisniku uz jednostavno procenjenje racuna. Jamstvo se sastoji u zamjeni neispravnih dijelova. Ovoj se jamstvo ne primjenjuje u slucaju uporabe i eksploatacije koja nije sukladna standardima uređaja, niti u slucaju stete uzrokovane neovlaštenim intervencijama ili nemarkom kupca. Jamstvo se ne primjenjuje na stetu uzrokovanu nekim nedostatkom alata.

SERVICE APRÈS VENTE - AFTER SALE SERVICE

FARGROUP EUROPE - 192, Avenue Yves Farge - 37700 St. Pierre-des-Corps - FRANCE
fargroup@fargroup.net



FAR GROUP EUROPE

Une société du groupe **SIGMA**

192, Avenue Yves Farge
37700 St. Pierre-des-Corps
FRANCE

fartools.com

