

FAR one[®] TOOLS

- FR** Malaxeur (Notice originale)
- EN** Mixer (Original manual translation)
- DE** Mischer (Übersetzung aus dem Original-Anleitung)
- ES** Malaxadora (Traducción del manual de instrucciones originale)
- IT** Impastatrice (Traduzione dell'avvertenza originale)
- PT** Misturador (Tradução do livro de instruções original)
- NL** Mengmachine (Vertaling van de originele instructies)
- EL** Συσκευή μαλάξεων (Μετάφραση από τις πρωτότυπες οδηγίες)
- PL** Malakser (Tłumaczenie z oryginalnej instrukcji)
- FI** Sekoittaja (Käännös alkuperäisestä ohjeet)
- SV** Blandare (Översättning från originalinstruktioner)
- BU** машина за месене (Превод на оригиналната инструкция)
- DA** Blandemaskine (Oversættelse fra oprindelige brugsanvisning)
- RO** Malaxor (Traducere din instrucțiunile originale)
- RU** мешалка (Перевод с оригинальной инструкции)
- TU** Karıştırıcı (Orijinal talimatlar çeviri)
- CS** Míchací stroj (Překlad z originálního návodu)
- SK** Miešací stroj (Preklad z originálneho návodu)
- HE** בקמ שיטפ (מכשיר לחיתוך לחיות)
- AR** (فيصل أصل تاميلعلعل نلم قلمجرتل) باشخألأ رشن قنلنلم
- HU** Keverő (Fordítás az eredeti utasítások)
- SL** Mešalnik (Prevod iz izvornih navodil)
- ET** Mikser (Tõlge originaal juhiseid)
- LV** Maisītājs (Tulkojumā no instrukcijas oriģinālvalodā)
- LT** Maišytuvas (Vertimas iš originalių instrukcijos)
- HR** Mikser (Prijevod prema originalne upute)



MI 1200P Professional Machine



© FAR GROUP EUROPE

116554-Manual-B-20221206



fartools.com



5 min

Description et repérage des organes de la machine
 Description and location of machine parts

A



Assemblage de la machine
 Assembling the machine

D

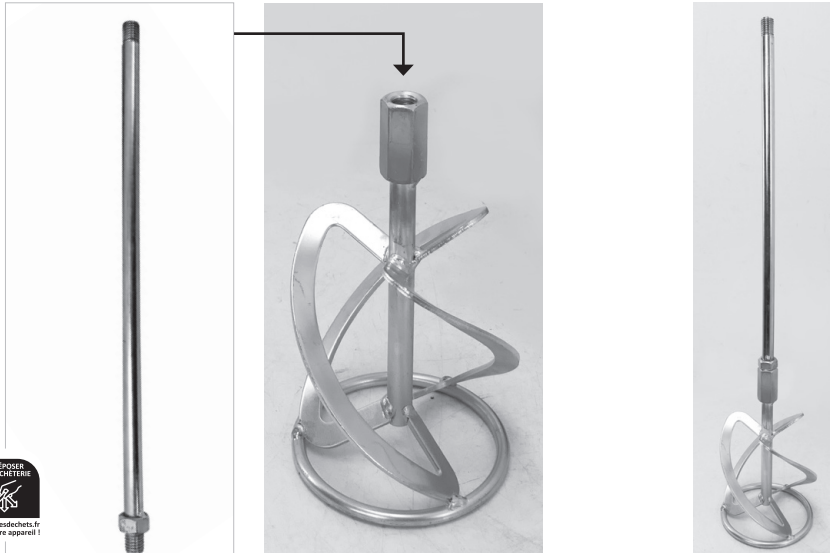

Points de collecte sur www.quefaireindemarche.be
 Privilégiez la réparation ou le don de votre appareil !

Assemblage de la machine
Assembling the machine

D

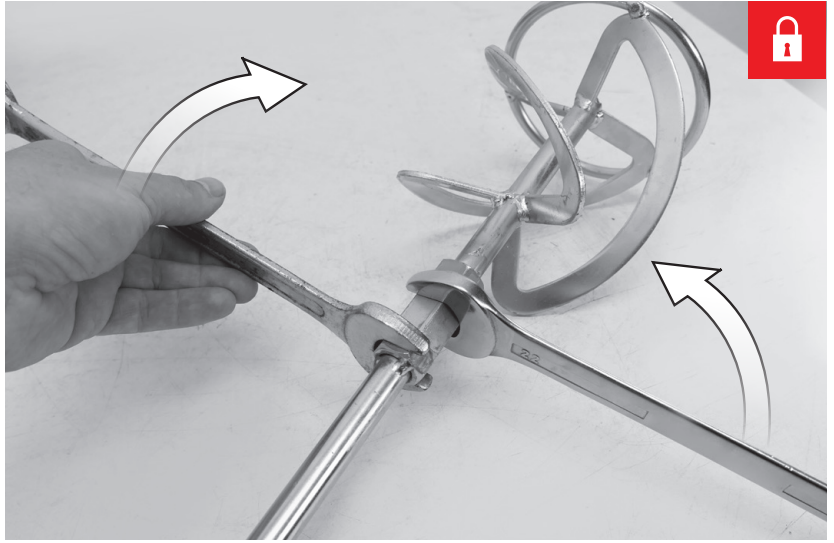

M 14



Fonctionnalité de la machine
Functions of the machine

E

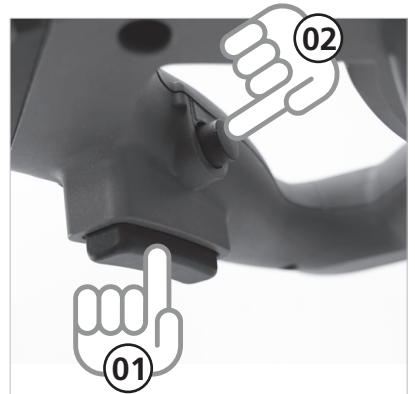
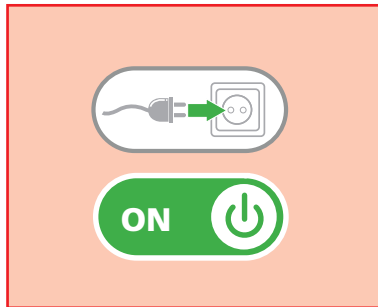



Nettoyage
de la machine
Machine cleaning

F



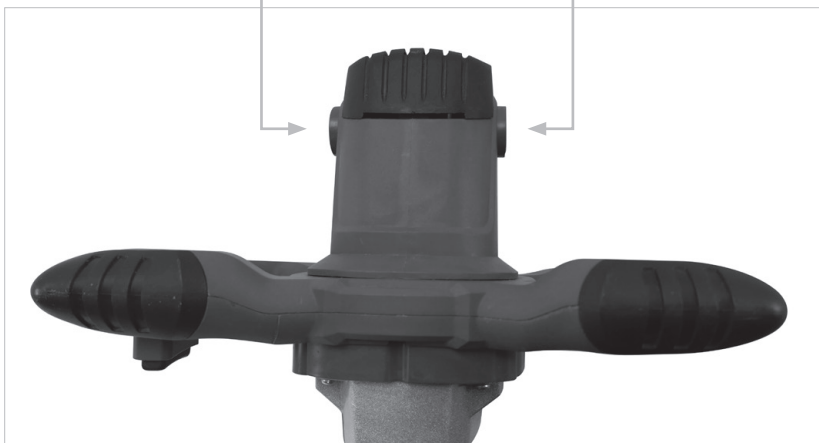
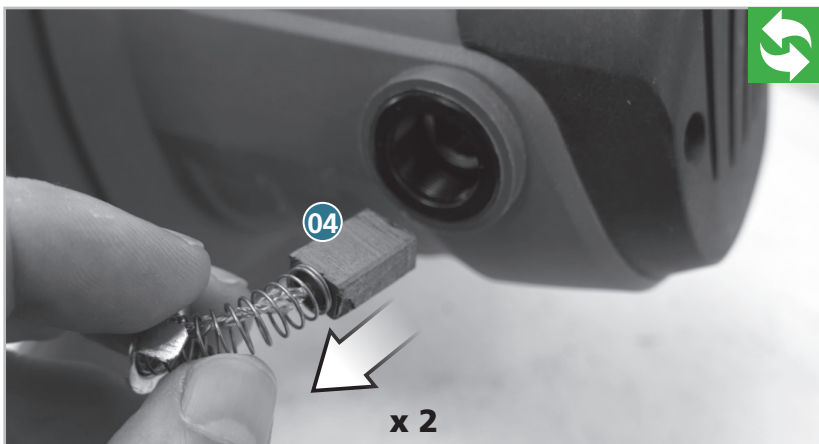

Remplacement des
consommables
Consumables
replacing

G





	<p>Tension et fréquence assignée: Nominal frequency and power: Spannung und Frequenz: Tensión y frecuencia fijada: Tensione e frequenza assegnata: Tensão e frequência fixa: Aangewezen spanning en frequentie: Ονομαστική τάση και συχνότητα: Napięcie i częstotliwość przydzielona: Jännite ja määrätty taajuus: Angiven spänning och frekvens: Anført spænding og frekvens: Tensiune și frecvență de lucru:</p>	<p>Заданное напряжение и частота: Tahsis gerilimi ve frekansı: Stanovené napětí a frekvence: Stanovené napätie a frekvencia: מחצת ותדר מוקצב الفلطية والذبذبة المبرمجة. Névlleges feszültség és frekvencia: Napetost in določena frekvenca: Консумирано напрежение и честота : Määratud pinge ja sagedus Nustatytą iłtampą ir dažnis Noteiktas spriegums un frekvence. Napon i nazivna frekvencija:</p>	230 V ~ 50 Hz
---	--	--	----------------------

	<p>Puissance assignée: Nominal power: Leerlaufdrehzahl: Potencia fijada: Potenza assegnata: Potência assinada: Onbelast toerental: Ονομαστική η ισχύς : Prędkość na biegu jałowym: Teho: Angiven effekt: Anført styrke: Putere de lucru:</p>	<p>Заданная мощность: Tahsis edilen güç: Stanovený příkon: Predpísaný výkon: כוח מוקצב. القدرة المبرمجة. Névlleges teljesítmény : Določena jakost: Консумирана мощност: Määratud võimsus. Nustatytą galia Noteiktā jauda Nazivna snaga:</p>	1200 W
---	--	--	---------------

	<p>Vitesse à vide: No-load speed: Drehzahl unbelastet: Velocidad vacía: Velocità a vuoto: Velocidade no vácuo: Leerlaufdrehzahl: Ταχύτητα στο κενό: Prędkość bez obciążenia: Tyhjäkäyntinopeus Tomgångshastighet: Hastighed i ubelastet tilstand: Viteza în gol:</p>	<p>Скорость вращения на холостом ходу: Boşalma hızı: Rychlost naprázdno: Rýchlosť pri chode naprázdno: מהירות ריק. السرعة على الفارغ. Üres sebesség: Prosti tek: Скорост на празни обороти: Kiirus tühikäigul Tušćio prietaiso greitís Tukšgaitas ātrums Brzina praznog hoda:</p>	500-1050 min⁻¹
---	--	--	----------------------------------

		M 14
---	--	-------------

	<p>Classe d'isolement : 2 Insulation class : 2 Isolierung klasse : 2 Aislamiento clase :2 Isolamento classe :2 Isolamento classe :2 Isolatie Klasse : 2 Εργαλειο τάξη : 2 Izolacja Klasy :2 Eristysluokka :2 Isolering Klass :2 Isoleringsklasse 2 Clasă izolație :2</p>	<p>Класс изоляции 2 : Yalıtım derecesi :2 Třída izolace :2 Izolačný systém 2 סוג בידוד 2. فئة العزل 2. Szigetelési osztály :2 Razred izolacije :2 Инструмент Клас :2 Isolatsiooniklass 2 Izolaciijos rūšis 2 Izolācijas klasē 2 Izolacija klasa: 2</p>	X
---	--	---	----------

	Porter des lunettes de sécurité : Wear protective eyewear : Schutzbrille tragen : Llevar puestas gafas protectoras : Portare de gli occhiali di sicurezza : Utilizar óculos de segurança : Draag een veiligheidsbril : Φορέστε Προστατευτικά γυαλιά : Zakładać okulary ochronne : Käytä suojalaseja : Använd skyddsglasögon : Der skal benyttes sikkerhedsbriller : Purtati ochelari de protecție :	Наденьте защитные очки : Güvenlik gözlükleri takın : Ποιζήνετε безпечностні брýле : Noste ochranné okuliare : תוהיטב יפקשמ בכרהל אן عمل نظارات وقائية Viseljen védőszemüveget : Nositi zaščitna očala : Да се използват защитни очила : Kandke kaitseprille Nešioti apsauginius akinius Valkät aizsargbrilles Nositi zaštitne naočale:	X
---	---	--	---

	Porter un masque anti-poussière : Wear a dust mask : Staubschutzmaske tragen : Llevar puesta una careta de protección contra el polvo : Indossare una mascherina anti-polvere : Utilizar uma máscara anti-poeira : Draag een stofmasker : χρήση προστατευτική μάσκα : Zakładać maskę przeciwpyłową Käytä pölysuojut : Bär mask mot damm : Der skal benyttes beskyttelsesmaske mod støv: Purtati mască anti-praf :	Наденьте респиратор : Toza karşı maske takın : Používejte masku proti prachu : Noste ochrannú masku proti prachu : קבא דגג הכסמ שובחל אן لبس قناع مضاد للغبار Viseljen porvédő maszkot Nositi zaščitno masko proti prahu: Да се използва защитна маска : Kandke tolmumaski. Dévėti respiratorių Valkät aizsarg masku pret putekļiem Nositi masku za zaštitu od prašine:	X
---	---	--	---

	Porter une protection auditive : Wear hearing protective equipment: Gehörschutz tragen: Llevar puesta una protección auditiva: Portare una protezione uditiva: Utilizar uma protecção auditiva: Draag gehoorbeschermers: Φορέστε Προστατευτικά ακουστικά Zakładać słuchawki ochronne Käytä kuulosuojaimia: Bär hörselskydd: Der skal benyttes høreværn: Purtati căști de protecție auz:	наденьте средства звуковой защиты: İşitsel koruma aleti takın: Používejte ochranu sluchu: Noste ochranné slúchadlá: יש ל הרכיב הגנת שמיעה لبس خوذة خض الخضحيج Viseljen fülvédőt Nositi zašito ušes: Да се използва слухови защитни средства: Kandke kõrvakaitset Nešioti apsaugą nuo triukšmo Valkät dzirdes aizsarglīdzekli Nositi štitnike protiv buke:	X
--	---	---	---

	Porter des gants : Use rubber gloves : Schutzhandschuhe tragen : Llevar guantes de protección : Indossare i guanti di protezione : Utilizar luvas de protecção : Draag veiligheidshandschoenen : χρήση προστατευτικών γαντιών : Używać rękawic ochronnych : Käytä suojakäsineitä : Använd skyddshandskar : Der skal benyttes handsker : Purtati mănuși :	Наденьте перчатки : Eldiven takın : Noste rukavice : Noste rukavice : תופכ שובלל אן لبس قفازات Viseljen kesztű t Nositi rokavice: a se използват предпазни ръкавици : Kandke kindaid Müvēti pirštines Valkät cimdus Nositi zaštitne rukavice:	X
---	--	---	---

	<p>Lire les instructions avant usage : Read the instructions before use : Vor Einsatz des Geräts Anweisung lesen : Léase las instrucciones antes de usar : Leggere le istruzioni prima dell'uso : Ler as instruções antes da utilização : Lees voor het gebruik de instructies : Διαβάστε τις οδηγίες χρήσης : Zapoznać się instrukcją przed użyciem : Lue ohjeet ennen käyttöä : Läs anvisningarna före användning : læs instruktionerne før brug : Înainte de utilizare, citiți instrucțiunile :</p>	<p>Внимательно прочитайте следующие инструкции : Kullanmadan talimatları okuyunuz : Pozorně si přečtěte následující pokyny : Pred použitím si prečítajte pokyny : זורם חילופי اقرأ التعلیمات قبل الاستخدام használat előtt olvassuk el az utasítást : Pred uporabo preberite ustrezna navodila Прочетете указанията за употреба : Enne kasutamist lugege instruksiooni Prieš naudojimą perskaityti instrukciją izlasīt instrukcijas pirms lietošanas Pročitati upute prije uporabe:</p>	X
---	--	--	---

	<p>Conformité européenne Conforms to EC standards : CE-Konformität : Cumples con las directivas CE : Conforme alle norme CE : Conforme às normas CE : Voldoet aan de EG-normen : Συμφώνο με τα πρότυπα Zgodność z normami CE : EU-standardien mukainen : EU-standardien mukainen : Overholder EU standarderne : Conform cu normele europene:</p>	<p>соответствие европейским стандартам: Avrupa uygunluk : evropská shoda : európska dohoda : התאמה לתקנים האירופיים مطابق للمواصفات الأوروبية. evropska ustreznost : európai megfelelőség : Съответствие с европейските норми : Euroopa Liidu vastavusmärk Europinių normų atitikima Atbilstība Eiropas standartiem Europska sukladnost</p>	X
---	--	---	---

	<p>Danger : Danger : Gefahr : Peligro : Pericolo : Perigo : Gevaar : Κινδύος : Niebezpieczeństwo : Vaara : Fara : Fare : Pericol :</p>	<p>Опасно : Tehlike : Nebezpečí : Nebezpečstvo : סכנה. خطر. Veszély : Nevamost : Опасност : Oht Pavojus Bistamība Опасност:</p>	X
--	--	---	---

	<p>Poids : Weight : Gewicht : Peso : Peso : Peso : Gewicht : Βάρος : Masa : Paino : Vikt : Vægt : Greutate :</p>	<p>Вес : Ağırlık : Hmotnost : Hmotnosť : משקל الوزن. Súly : Teža : Терло : Raskus Svoris Svars Težina</p>	3,4 kg
---	--	--	--------

 L_{pA}	Niveau de pression acoustique :	Уровень акустического давления :	87 dB (A)
	Acoustic pressure level :	Akustik basınç seviyesi :	
	Schalldruckpegel :	Hladina akustického tlaku :	
	Nível de pressão acústica :	Hladina akustického tlaku :	
	Livello di pressione acustica :	רמת לחץ אקוסטי :	
	Nível de pressão acústica :	مستوى الضغط السمعي :	
	Niveau akoestische druk :	A hangnyomás szintje :	
	Στάθμη Θορύβου :	Nivo akustičnega pritiska :	
	Poziom mocy akustycznej :	Равнище на акустично налягане :	
	Käytä kuulosuojaimia :	Heliröhu nivoo	
	Ljudtrycksnivå :	Akustinio spaudimo lygis	
Lydtryk :	Akustiskā spiediena līmenis		
Nível presiune acustică :	Razina zvučnog tlaka :		

 L_{WA}	Niveau de puissance acoustique :	уровень мощности звука :	98 dB (A)
	Acoustic power level :	Akustik basınç seviyesi :	
	Schalleistungspegel :	Hladina zvukového výkonu :	
	Nível de potencia acústica :	Hladina zvukového výkonu :	
	Livello di potenza acustica :	רמת כוח אקוסטי :	
	Nível de potência acústica :	مستوى الضجيج :	
	Niveau akoestisch vermogen :	a hangnyomás szintje :	
	Στάθμη Ονομαστική Θορύβου :	Nivo akustične jakosti :	
	Poziom mocy akustycznej :	Равнище на вибрации :	
	Käytä suojalaseja :	Helivõimsuse nivoo	
	Ljudstyrkenivå :	Triukšmo lygis	
Lydstyrke :	Akustiskās jaudas līmenis		
Nível putere acustică :	Razina zvučne snage :		

NIVEAU SONORE D'EMISSION:

A VIDE

Pression acoustique L_{pA} poste opérateur
Incertitude

87 dB
3

Puissance acoustique L_{WA}
Incertitude

98 dB
3

Valeurs déterminées suivant le code d'essai de l'annexe B de la norme EN 61029-1 avec emploi des normes de base ISO 11201 et ISO 3744.

Les niveaux de pression acoustique obtenus in situ dépendent:

- Des niveaux réels de la machine considérées, en prenant en compte les incertitudes déclarées;
- Du local et de l'installation de la machine. Préférez une pièce dont l'acoustique est plus feutrée. Evitez les pièces vides à grande résonance. Placez vous auprès d'une fenêtre le cas échéant.
- Des outils montés, des pièces travaillées, des réglages choisis,...

	Niveau de vibration :	Уровень вибрации :	4,04 m / S²
	Hand/arm vibration level :	Titreşim seviyesi :	
	Vibrationspegel Hand/Arm :	Úroveň vibrací :	
	Nível de vibración mano/brazo :	Hladina vibrácií :	
	Livello di vibrazione mano/braccio :	רמת תנודות	
	Nível de vibração mão/braço :	مستوى الارتجاج :	
	Trillingsniveau hand/arm :	Vibrációszint :	
	Στάθμη κρατ/οαστόμιν :	Nivo vibracij :	
	Poziom wibracji rżka/ramię :	Равнище :	
	Tärinätaso:	Vibrācijas līmenis.	
	Vibrationsnivå hand/arm :	Vibrācijas lygis	
Vibrationsniveau :	Vibratsiooni nivo		
Nível vibratii :	Razina vibracije:		

VIBRATIONS:

Total des valeurs de vibration (somme vectorielle des trois directions) déterminée selon EN 60745:

a_{hvw} (travail du bois)
Incertitude K_{ov}

4,04 m/s²
1,5 m/s²

L'amplitude d'oscillation peut être utilisée comme valeur de comparaison d'outils électroportatifs.

Attention : si l'outil électroportatif est utilisé pour d'autres applications, avec d'autres outils de travail, l'amplitude d'oscillation peut être différente.

	<p>Soumis à recyclage Subjected to recycling Sujeto a reciclaje Sottoposti a riciclaggio Sujeitos à reciclagem Não deite no lixo : Niet wegwerpen : Μην την πετάτε : Nie wyrzucas : Älä heitä pois luontoon : Batteriet får inte kastas : Bortkast det ikke: Nu le auncati :</p>	<p>Не выбрасывайте в мусорный ящик Atmayıniz : Nevyhazujte je do bežného odpadu : Neodhadzovat : אין לזרוק סוללות فلا ترمدها هكذا في القمامة. ne mečíte! Ne odvržite ga/jih vstran : Не го изхвърляйте : Ärge visake seda minema : Nemetykíte : Nemest : Podvrgnuto recikliranju</p>	X
---	--	--	---

Recyclage des déchets :

Les outils, accessoires et leur emballages doivent suivre une voie de recyclage adaptée. Conformément aux directives Européenne 2012/19/UE et 2006/66/CE, les composants d'un produit doivent être séparés, collectés, recyclés ou éliminés en conformité avec les réglementations environnementales en vigueur. Les appareils, batteries, piles, huiles, emballages devront être déposés dans les systèmes d'élimination des déchets spéciaux tels que déchetteries. Renseignez-vous auprès de votre commune pour connaître l'organisme le plus proche à même de retraiter ou de collecter ces déchets.

	<p>Recyclable, soumis au tri sélectif Recyclable, subject to recycling Recyclingfähige, unterliegen Recycling Reciclables, sujetos a reciclaje Riciclabili, soggetti a riciclaggio Recicláveis, sujeito à reciclagem Recycleerbare, onderworpen aan recycling Ανακυκλώσιμες συσκευασίες που υπόκεινται σε κύκλωση Opakowanie nadaje się do recyklingu podlegają recyklingu Kierrätettävien pakkausten kohteena kierrätys Återvinningsbara förpackningar omfattas återvinning Рециклиращи се опаковки подлежат на рециклиране Genavendelig underlagt genbrug</p>	<p>Reciclabile sub rezerva reciclare Повторно опаковка подлежит вторичной переработке Geri dönüşüm Geri dönüşdürülebilir ambalaj konusu Recyklovateľné podléhajúce recykláci Recyklovateľné podliehajúce recyklácii רוחמל רוחמל היראה אשונ رېودنلدا هدا ځال ځېړنځن رېودنلدا هدا ځال ځېړنځال اغېل ځېړل او ځېړ ځېړلدا Újrahasznosítható csomagolás alá újrahasznosítás Reciklirati predmet recikliranja Pakendite suhtes ringlussevõtu Pärsträdājams iepakojuoms otrreizējai pārstrādei Perdirbamų taikomos perdirbimo Može se reciklirati, podložno selektivnom sortiranju</p>	X
---	---	--	---

MI 1200P

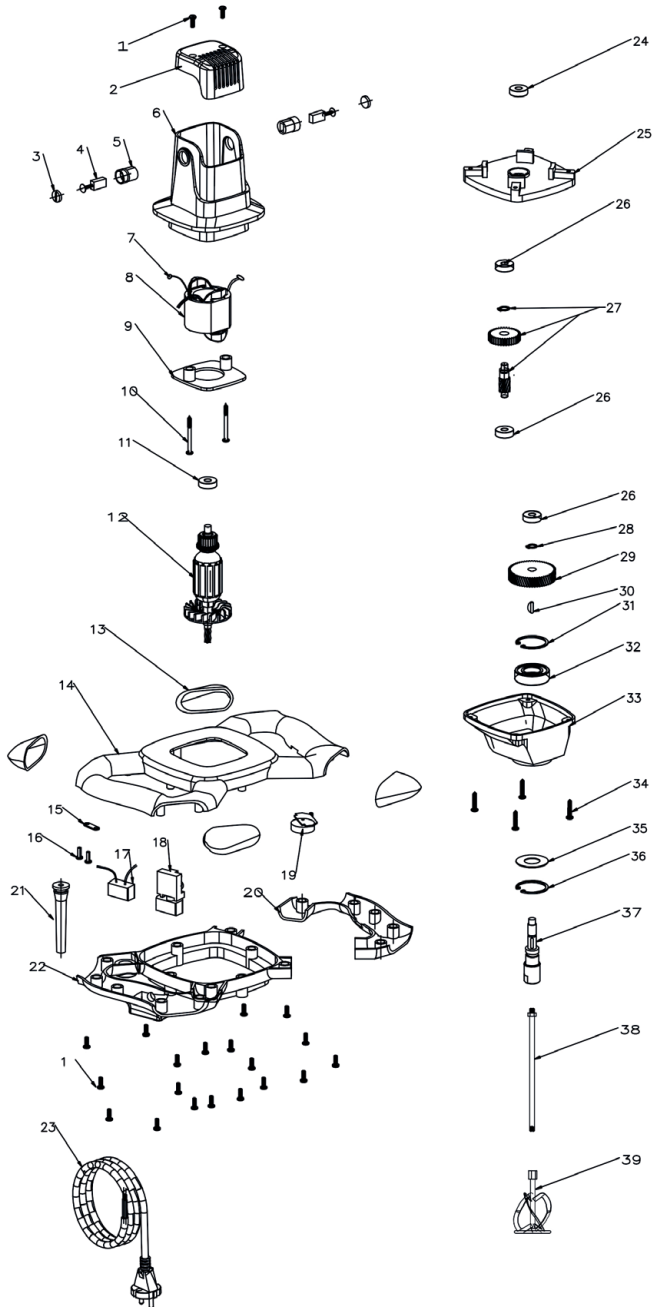

DECLARATION DE CONFORMITE
VERKLARING VAN OVEREENSTEMMING
DECLARACION DE CONFORMIDAD
DICHIARAZIONE DI CONFORMITA
KONFORMITÄSERKLÄRUNG
DECLARATION OF CONFORMITY
DECLARAÇÃO DE CONFORMIDADE
DEKLARACJA ZGODNOSCI Z NORMAMI
OM ÖVERENSSTÄMMELSE
VAATIMUSTENMUKAISUUSVAKUUTUS
OVERENSSTEMMELSEERKLÆRING
Δήλωση συμμόρφωσης/συμμόρφωσης

DECLARAȚIE DE CONFORMITATE
VYHLÁSENIE ZHODY
Декларация соответствия
תוצרת תואמת
Uygunluk beyanı
التصريح بال مطابقة
PROHLÁŠENÍ SHODY
EGYZEŐSÉGI NYILATKOZAT
Декларация за съответствие с нормите
IZJAVA O SKLADNOSTI
DEKLARACIJA
ΑΤΤΙΚΤΗΣ DEKLARACIJA
KINNITUS
IZJAVA O SUKLADNOSTI

Le soussigné,
Ondergetekende,
Der Unterzeichner,
O abaixo assinado,
Undertecknad,
Долуподписаният
Undertegnede
Subsemnatul,
Я, нижеподписавшийся,
Imzalayan,
Niže podepsany,
Toliau pasirašęs

Déclare par la présente que,
Verklaart hiermede dat,
Erklärt hiermit daß,
Declara pela presente que,
Förklarar härmed att
Заявляя с настоящото
erklærer hermed, at
Declar prin prezenta că,
настоящим подтверждаю, что
Mevcut belgeyle beyan ediliyor ki,
tinto proklaŝuje, že,
Pareiškia, kad,

Personne autorisée à constituer
le dossier technique :
Ronan GUILLIOT



FAR GROUP EUROPE
192, Avenue Yves Farge
37700 St. Pierre-des-Corps
FRANCE

El suscrito,
Il sottoscritto,
The undersigned,
Níneį podpisany
Allekirjoittanut,
Ουπογεγραμμένος
Nižšie podpisany
מטה תחתום,
الذوق ع أدناه
Alulírott,
Podpisani,
Apakšā parakstījies
allakirjutanu
Dolje potpisani,

Declara por la presente, que,
Dichiare che,
Declares that,
OOviadacza niniejszym, że
Ilmoitetaan täten että,
Δηλώνω με την Παράστα
týmto vyhlasuje, že
מצהיר בזה כי
يصدح إستماداً على ذلك
kijelentem, hogy a készőlék Izjavlja da,
Pareiškia, kad,
Ar šo apliecina, ka,
Kinnitab, et
Izjavljuje u ovom dokumentu da je

Malaxeur / Mixer / Mischer / Malaxadora / Impastatrice / Misturador / Mengmaschine /

Συσκευή μαλάξεων / Malakser / Sekoittaja / Blandare / машина за месене / Blandemaskine / Malaxor /
мешалка / Karıştırıcı / Míchací stroj / Miešací stroj / תיחול ותחיל רישכמ / باشخال رشن قنلام / Keverő /
Mešalnik / Mikser / Maisītājs / Maišytuvus / Mikser

code

Fartools / 116554 / MI 1200P / M-1200

Est conforme et satisfait aux directives et normes CE,
In overeenstemming is met en Voldoet aan EG richtlijnen,
Den folgenden EU-Bestimmungen entspricht,
Respeita e está em conformidade com as normas CE,
Överensstämmer med och uppfyller EG-standarder,
Съответства и отговаря европейските норми
Er i overensstemmelse med og overholder EU standarderne
Este conform și satisface normele CE
полностью соответствует и удовлетворяет
требованиям стандартов ЕС
CE şartlara uygundur,
odpovídá normám ES.
Atitinka ir atitinka EB direktyvas ir standartus,

Cumple con la directivas de la CE,
E conforme alle direttive CEE,
Complies with the EEC directives and standards,
Odpowiada normom UE,
Täyttää EU-vaatimukset,
Είναι συμμόρφωνο και ανταποκρίνεται στα Πρότυπα CE
zodpovedá normám ES.
מתאים ועונה לתקני CE
بان الجهاز مطابق و يلبي م جميعاً الدولة الأوروبية
kielégíti a CE szabványok előírásait.
Je v skladu z in izpolnjuje norme Evropske skupnosti.
Atbilst un atbilst EK direktīvas un standartus,
Vastab ja vastab EÜ direktīvidele ja standārditeile,
Sukladan i ispunjava direktive i standarde CE,

2006/42/EC, 2014/30/EU, 2011/65/EU&2015/863/EU

EN 62841-1:2015+AC:15
EN 62841-2-10:2017
EN 55014-1:2017
EN 55014-2:2015
EN 61000-3-2:2014
EN 61000-3-3:2013

Ronan GUILLIOT,
Directeur général
06/12/2022
Fait à St. Pierre-des-Corps



FAR GROUP EUROPE

Une société du groupe **SIGMA**

192, Avenue Yves Farge
37700 St. Pierre-des-Corps
FRANCE

fartools.com

