

FAR TOOLS®



TE 1200B
Professional Machine

- FR Tarière électrique (Notice originale)
EN Power auger (Original manual translation)
DE Macht auger (Originalbetriebsanleitung)
ES De barrena (Traducción del manual originale)
IT Coclea di alimentazione (Traduzione dell'avvertenza originale)
PT Poder auger (Tradução do livro de instruções original)
NL Power vijzel (Vertaling van de originele instructies)
EL δύναμη τρυπάνι (Μετάφραση από τις πρωτότυπες οδηγίες)
PL Moc ślimaka (Tłumaczenie z oryginalnej instrukcji)
FI Teho Auger (Käännös alkuperäisestä ohjeet)
SV Ström skruv (Översättning från originalinstruktioner)
BU мощност шнека (Превод на оригиналната инструкция)
DA Strøm snegl (Oversættelse fra oprindelige brugsanvisning)
RO Puterea de melc (Traducere din instrucțiunile originale)
RU мощность шнека (Перевод с оригинальной инструкции)
TU Güç burgu (Orijinal talimatlar çeviri)
CS Výkon šnek (Překlad z originálního návodu)
SK Výkon slimák (Preklad z originálneho návodu)
HE תיורקם תוארוהם סוגרת) החדקמב חוב
AR (ةيصل ال تاميل عتلا نم قم جرتلا) ري جوا قظلسلا
HU Elektromos fúró (Fordítás az eredeti utasítások)
SL Moč sveder (Prevod iz izvirnih navodil)
ET Võim puuri (Tõlge originaal juhiseid)
LV Jauda svārpsts (Tulkojumā no instrukcijas oriģinālvalodā)
LT Galia sraigtas (Vertimas iš originalių instrukcijos)
HR Gustin za blanjanje (Prijevod prema originalne upute)



© FAR GROUP EUROPE

175305-2-Manual-D-20230703



fartools.com



3 min





Description et repérage des organes de la machine
Description and location of machine parts

A

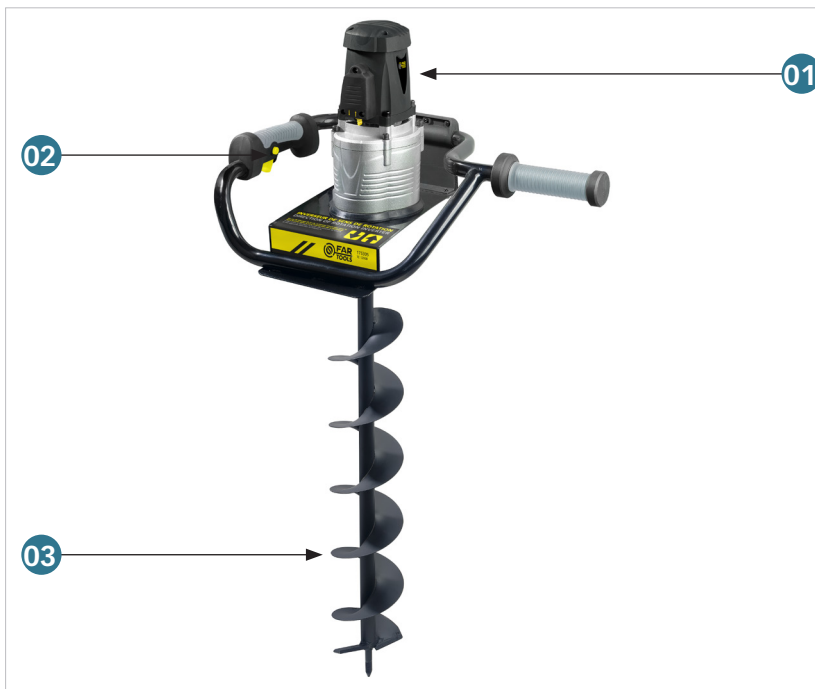

Contenu du carton
Contents of box

C

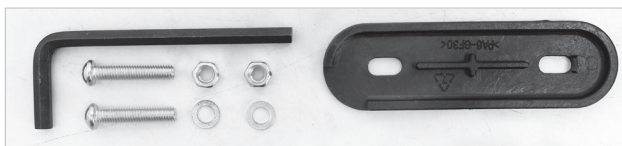

FR
Cet appareil se recycle
A DÉPOSER EN VERRE
OU
A DÉPOSER EN MÉTAL
Points de collecte sur www.quefaire-demarchets.fr
Privilégiez la réparation ou le don de votre appareil !





Assemblage de la machine
Assembling the machine

D

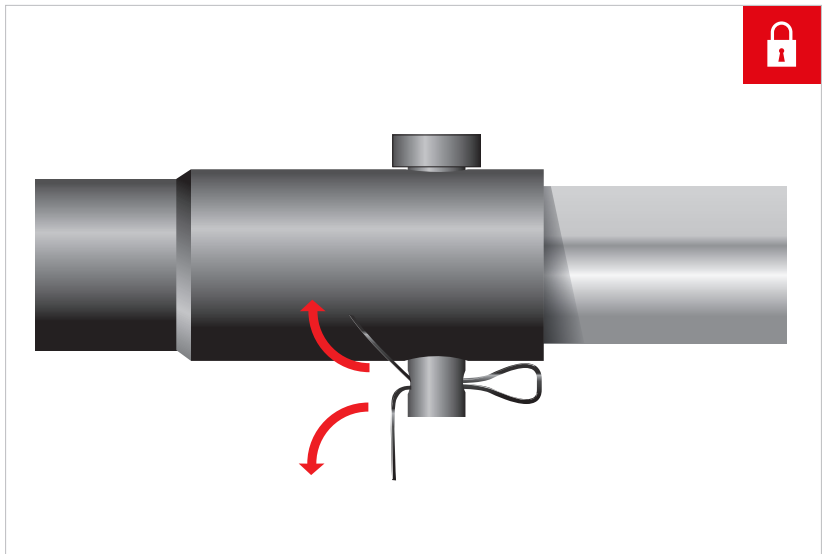
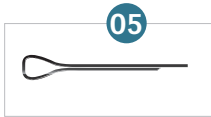
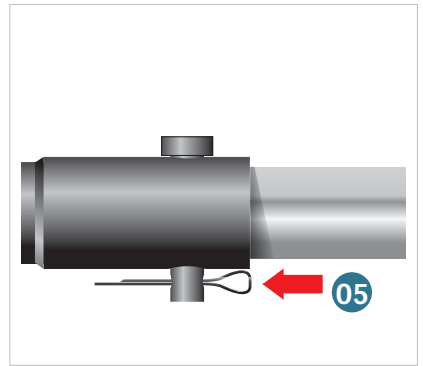
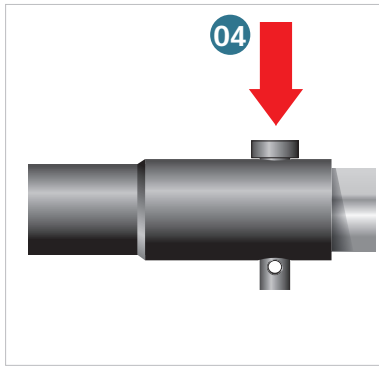
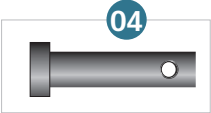
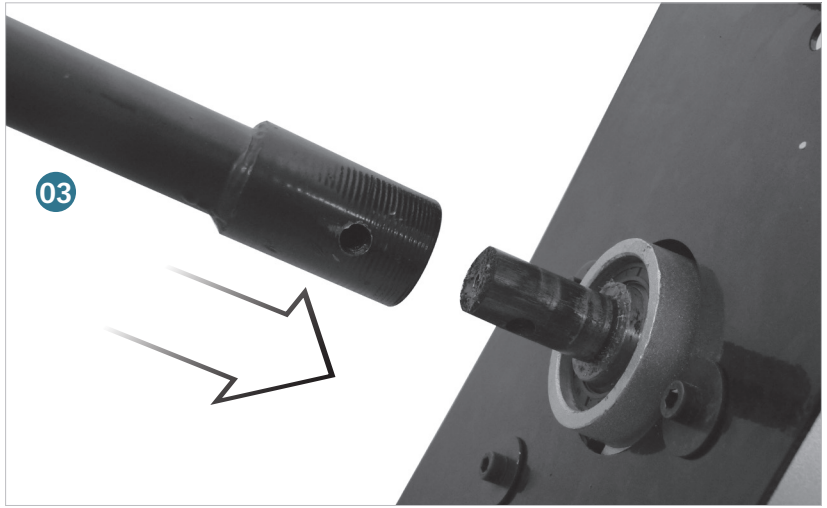



Assemblage de la machine
Assembling the machine

D

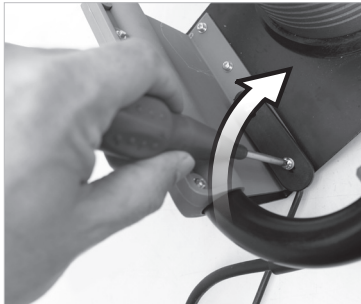
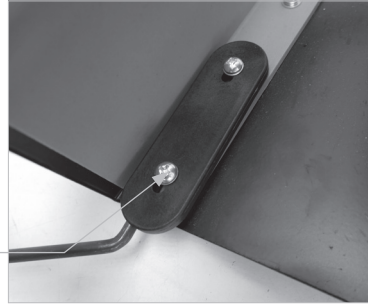
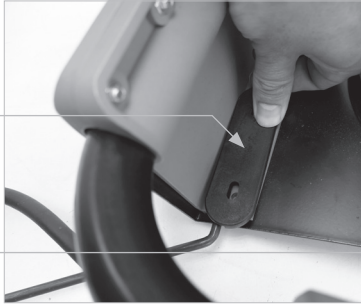
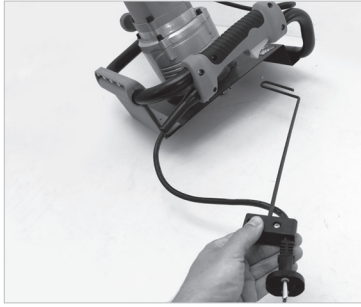



Fonctionnalité de la machine
Functions of the machine

E

01

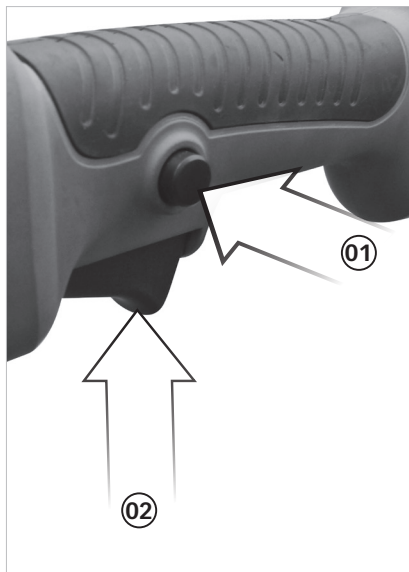
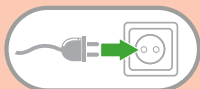

Position de travail à adopter

Werkpositie o
aan te nemen
Posición de trabajo
para adoptar
Posição de trabalho
para adotar
Posizione lavorativa
da adottare
Working position
to adopt





Fonctionnalité de la machine
Functions of the machine

E

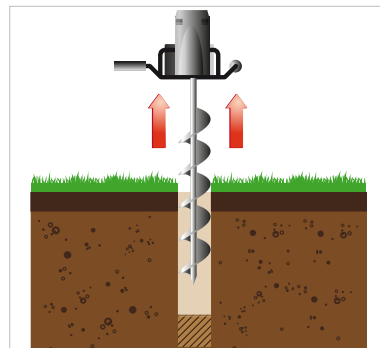
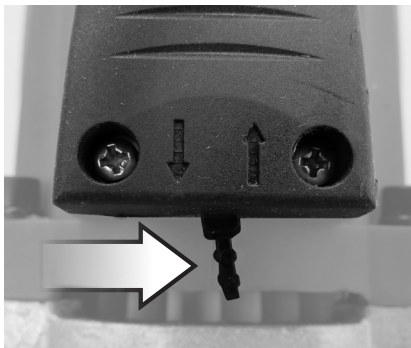
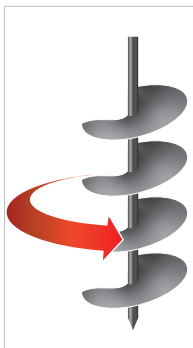
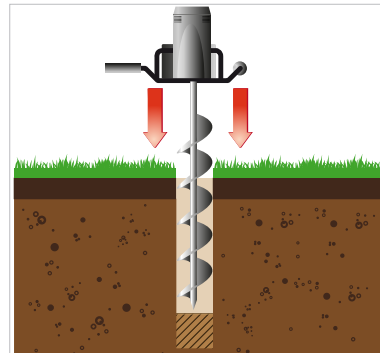
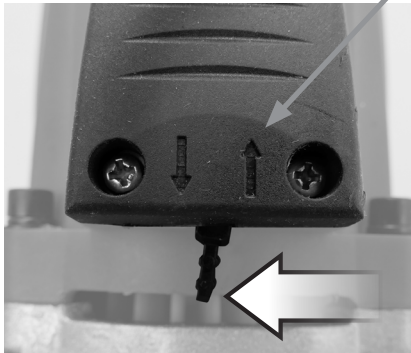
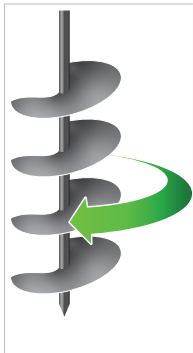
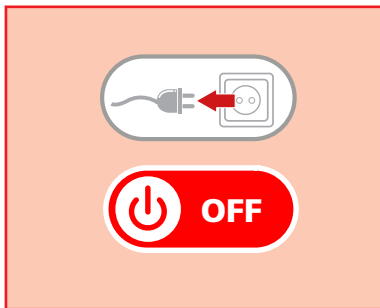

**Attention : Ne jamais enclencher l'inverseur de sens avec le moteur en marche.
Pour inverser le sens de rotation, éteindre et débrancher la machine. Risque élevé de casse du moteur !**

**Waarschuwing: Schakel de omkeerinrichting nooit in terwijl de motor draait.
Om de draairichting om te keren, schakelt u de machine uit en haalt u de stekker uit het stopcontact. Grote kans op motorbreuk!**

**Advertencia: Nunca active el inversor con el motor en marcha.
Para invertir el sentido de giro, apague y desconecte la máquina. ¡Alto riesgo de rotura del motor!**

**Advertência: Nunca engate o reversor com o motor funcionando.
Para inverter o sentido de rotação, desligue e desconecte a máquina. Alto risco de quebra do motor!**

**Avvertenza: non inserire mai l'invertitore con il motore acceso.
Per invertire il senso di rotazione, spegnere e scollegare la macchina. Elevato rischio di rottura del motore!**

**Warning: Never engage the reverser with the engine running.
To reverse the direction of rotation, switch off and unplug the machine. High risk of engine breakage!**





Fonctionnalité de la machine
Functions of the machine

E

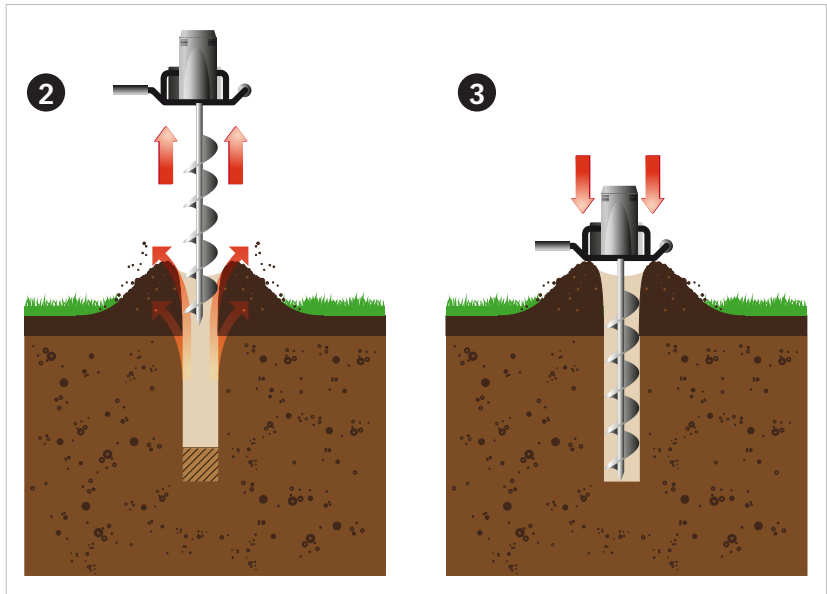
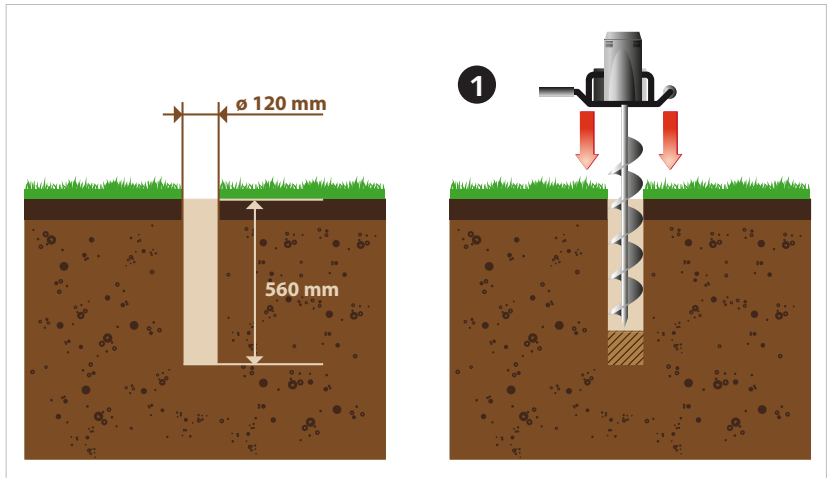



Fonctionnalité de la machine
Functions of the machine

E

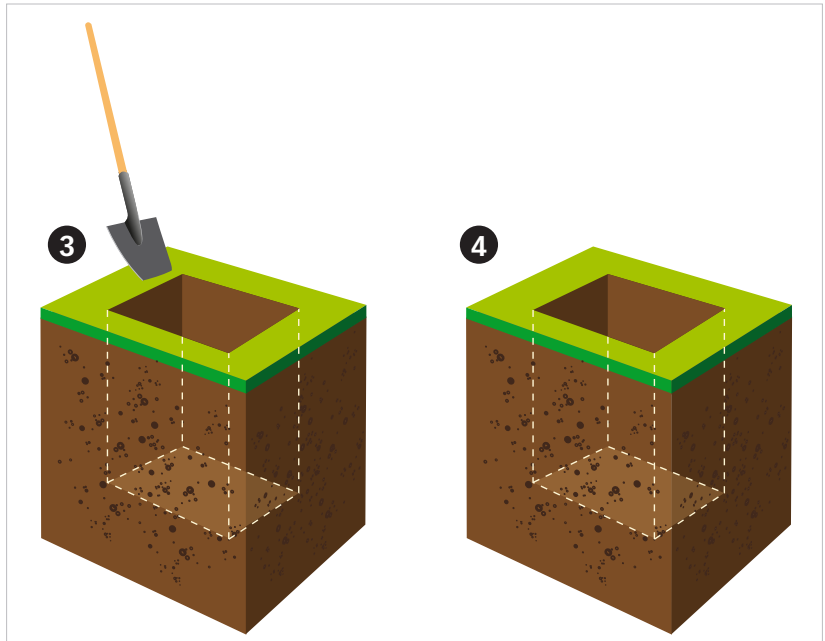
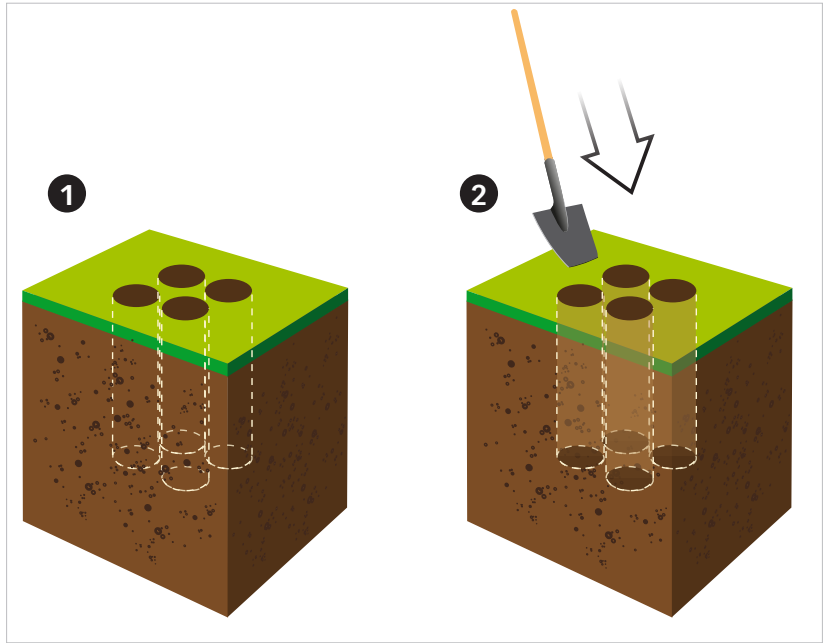



Fonctionnalité de la machine
Functions of the machine

E

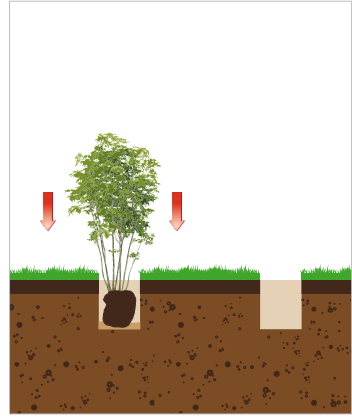
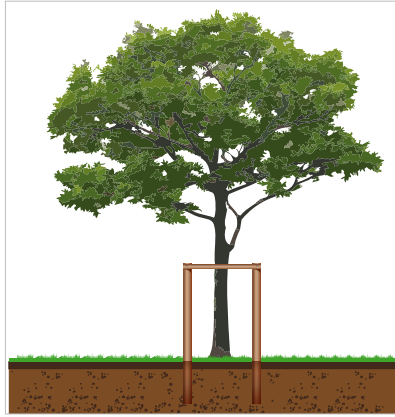

Débrayage automatique
Automatische uitschakeling
Desenganche automático
Desingate automático
Disinnesto automatico
Automatic disengaging

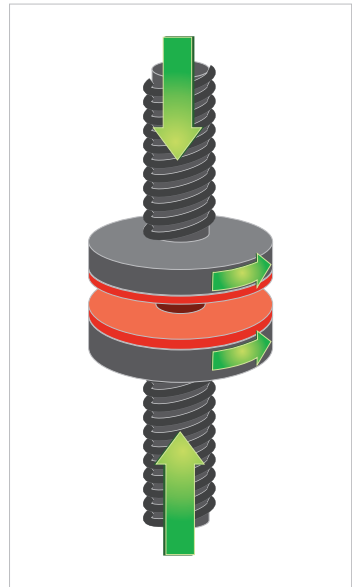
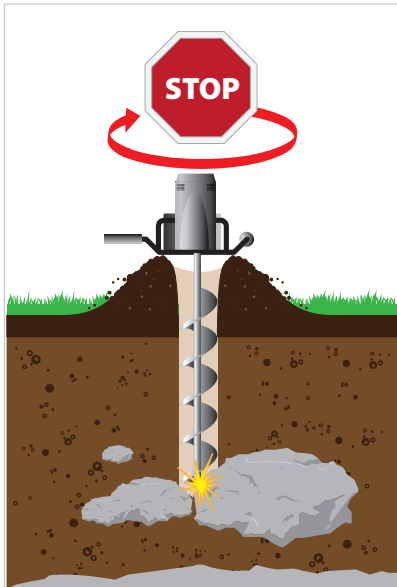

Ne pas approcher les mains /
pieds
Houd uw handen/voeten weg
Mantenga sus manos / pies
alejados
Mantenha suas mãos / pés longe
Tieni le mani / i piedi lontani
Do not approach hands / feet

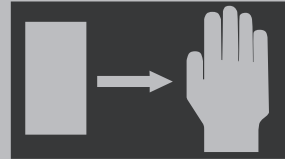



Remplacement des consommables
Consumables replacing



Option - Option - Option - Opcional - Opzione - Opção - Opție - π - Opcja - Valinnainen -
Tilival - Ekstra udstyr - Opțiune - Seçenek / seçim - Volba - Volba -
- رايي تځا - Opció - Možnost - Valik - Opcija - Izvēle

G



175306 :
Meche ø 80 x 560 mm
Schroef ø 80 x 560 mm
Tornillo ø 80 x 560 mm
Parafuso ø 80 x 560 mm
Brocas ø 80 x 560 mm
Drill ø 80 x 560 mm



175307 :
Meche ø 200 x 560 mm
Schroef ø 200 x 560 mm
Tornillo ø 200 x 560 mm
Parafuso ø 200 x 560 mm
Brocas ø 200 x 560 mm
Drill ø 200 x 560 mm

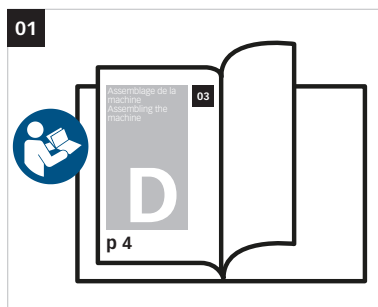
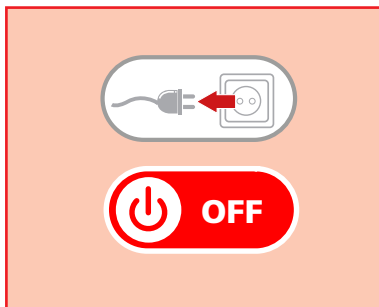



	<p>Tension et fréquence assignée: Nominal frequency and power: Nennspannung und Nennfrequenz : Tensión y frecuencia fijada: Tensione e frequenza assegnata: Tensão e frequência fixa: Angeweznen spanning en frequentie: ΟΝΟΜΑΣΤΙΚΗ ΤΑΣΗ ΚΑΙ ΣΥΧΝΟΤΗΤΑ: Napięcie i częstotliwość przydzielona: Jännite ja määrittäty taajuus: Angiven spänning och frekvens: Anført spænding og frekvens: Tensiune și frecvență de lucru:</p>	<p>Заданное напряжение и частота: Tahsis gerilimi ve frekans: Stanovené napětí a frekvence: Stanovené napätie a frekvencia: Merkespenning og merkefrekvens: الغليطية والذبذبة الجيرمجة. Névleges feszültség és frekvencia: Napetost in določena frekvenca: Консумирано напрежение и честота : Määratud pinge ja sagedus Nustatyta įtampa ir dažnis Noteiktais spriegums un frekvence. Napon i nazivna frekvencija:</p>	230 V ~ 50 Hz

	<p>Puissance assignée: Nominal power: Nennleistung: Potencia fijada: Potenza assegnata: Potência assinada: Onbelast toerental: ΟΝΟΜΑΣΤΙΚΗ ΙΣΧΥΣ: Prędkość na biegu jałowym: Teho: Angiven effekt: Anført styrke: Putere de lucru:</p>	<p>Заданная мощность: Tahsis edilen güç: Stanovený príkon: Predpísaný výkon: Merkeeffekt: القدرة الجيرمجة. Névleges teljesítmény : Določena jakost: Консумирана мощност: Määratud võimsus. Nustatyta galia Noteiktā jauda Nazivna snaga:</p>	1200 W

	<p>Vitesse à vide: No-load speed: Leerlaufdrehzahl: Velocidad vacía: Velocità a vuoto: Velocidade no vácuo: Leerlaufdrehzahl: ΤΑΧΥΤΗΤΑ ΑΔΡΑΝΕΙΑΣ: Prędkość bez bciążenia: Tyhjäkäyntinopeus Tomgångshastighet: Hastighed i ubelastet tilstand: Viteza în gol:</p>	<p>Скорость вращения на холостом ходу: Boşalma hızı: Rychlost naprázdno: Rychlost pri chode naprázdno: Tomgangshastighet: السرعة على الفارغ. Üres sebesség: Prosti tek: Скорост на празни обороти: Kiirus tühikäigul Tuščio prietaiso greitis Tukšgaitas ātrums Brzina praznog hoda:</p>	200 min ⁻¹





	<p>Porter des lunettes de sécurité : Wear protective eyewear : Schutzbrille tragen : Llevar puestas gafas protectoras : Portare de gli occhiali di sicurezza : Utilizar óculos de segurança : Draag een veiligheidsbril : ΦΟΡΑΤΕ ΠΡΟΣΤΑΤΕΥΤΙΚΑ ΓΥΑΛΙΑ: Zakładać okulary ochronne : Käytä suojalaseja : Använd skyddsglasögon : Der skal benyttes sikkerhedsbriller : Purtati ochelari de protecție :</p>	<p>Наденьте защитные очки : Güvenlik gözlükleri takın : Používejte bezpečnostní brýle : Noste ochranné okuliare : Bruk vernebriller: حَمَلْ نَظَارَاتٍ وَقَايَةَ Viseljen védőszemüveget : Nositi zaščitna očala : Да се използват защитни очила : Kandke kaitseprille Nešioti apsauginius akinius Valkät aizsargbrilles Nositi zaštitne naočale:</p>	×
---	--	---	---

	<p>Porter un masque anti-poussière : Wear a dust mask : Staubschutzmaske tragen : Llevar puesta una careta de protección contra el polvo : Indossare una mascherina anti-polvere : Utilizar uma máscara anti-poeira : Draag een stofmasker : ΦΟΡΕΣΤΕ ΜΑΣΚΑ ΓΙΑ ΤΗ ΣΚΟΝΗ: Zakładać maskę przeciwpylową Käytä pölysuojust : Bär mask mot damm : Der skal benyttes beskyttelsesmaske mod støv: Purtati mască anti-praf :</p>	<p>Наденьте респиратор : Toza karşı maske takın : Používejte masku proti prachu : Noste ochrannú masku proti prachu : Bruk en støvmaske: لبس قِذَاعٍ مَضْرُوعٍ لِلْعِيَارِ Viseljen porvédő maszkot Nositi zaščitno masko proti prahu: Да се използва защитна маска : Kandke tolumaski. Dėvėti respiratorių Valkät aizsarg masku pret putekļiem Nositi masku za zaštitu od prašine:</p>	×
---	---	---	---

	<p>Porter une protection auditive : Wear hearing protective equipment: Gehörschutz tragen: Llevar puesta una protección auditiva: Portare una protezione uditiva: Utilizar uma protecção auditiva: Draag gehoorbeschermers: ΦΟΡΑΤΕ ΠΡΟΣΤΑΣΙΑ ΑΚΟΗΣ: Zakładać słuchawki ochronne Käytä kuulosuojaimia: Bär hörselskydd: Der skal benyttes hørevern: Purtati căști de protecție auz:</p>	<p>наденьте средства звуковой защиты: İşitsel koruma aleti takın: Používejte ochranu sluchu: Noste ochranné slúchadlá: Bruk hørselsvern: لبس خُوْدَةِ خُرُوضِ الْخُرُوجِ Viseljen fülvédőt Nositi zašitno ušes: Да се използва слухови защитни средства: Kandke kõrvakaitset Nešioti apsaugą nuo triukšmo Valkät dzirdes aizsarglīdzekli Nositi štitnike protiv buke:</p>	×
---	--	---	---

	<p>Porter des gants : Use rubber gloves : Scchutzhandschuhe tragen : Llevar guantes de protección : Indossare i guanti di protezione : Utilizar luvas de protecção : Draag veiligheidshandschoenen : ΦΟΡΩΝΤΑΣ ΓΑΝΤΙΑ: Używać rękawic ochronnych : Käytä suojakäsineitä : Använd skyddshandskar : Der skal benyttes handsker : Purtati mánuşi :</p>	<p>Наденьте перчатки : Eldiven takın : Noste rukavice : Noste rukavice : Bruk hansker: لبس قِغَاذَاتِ Viseljen kesztyű t Nositi rokavice: а се използват предпазни ръкавици : Kandke kindaid Mūvēti pirštines Valkät cimds Nositi zaštitne rukavice:</p>	×
---	--	--	---



	<p>Lire les instructions avant usage : Read the instructions before use : Vor Einsatz des Geräts Anweisung lesen : Léase las instrucciones antes de usar : Leggere le istruzioni prima dell'uso : Ler as instruções antes da utilização : Lees voor het gebruik de instructies : ΔΙΑΒΑΣΤΕ ΤΙΣ ΟΔΗΓΙΕΣ ΠΡΙΝ ΑΠΟ ΤΗ ΧΡΗΣΗ: Zapoznać się instrukcją przed użyciem : Lue ohjeet ennen käyttöä : Läs anvisningarna före användning : læs instruktionerne før brug Înainte de utilizare, citiți instrucțiunile :</p>	<p>Внимательно прочитайте следующие инструкции : Kullanmadan talimatları okuyunuz : Pozorně si přečtěte následující pokyny : Pred použitím si prečítajte pokyny : Les bruksanvisningen før bruk: اقرأ التعليمات قبل الاستخدام. használat előtt olvassuk el az utasítást : Pred uporabo preberite ustrezna navodila Прочетете указанията за употреба : Enne kasutamist lugege instruksiooni Prieš naudojimą perskaityti instrukciją izlasīt instrukcijas pirms lietošanas Pročitati upute prije uporabe:</p>	X
--	--	---	---

	<p>Conformité européenne Conforms to EC standards : CE-Konformität : Cumple con las directivas CE : Conforme alle norme CE : Conforme às normas CE : Voldoet aan de EG-normen : ΕΥΡΩΠΑΪΚΗ ΣΥΜΜΟΡΦΩΣΗ Zgodność z normami CE : EU-standardien mukainen : EU-standardien mukainen : Overholder EU standarderne : Conform cu normele europene:</p>	<p>соответствие европейским стандартам: Avrupa uygunluk : evropská shoda : európska dohoda : Europeisk konformitet مطابق للمواصفات الأوروبية. evropska ustreznost : európai megfeleléség : Съответствие с европейските норми : Euroopa Liidu vastavusmärk Europinių normų atitikima Atbilstība Eiropas standartiem Evropska sukladnost</p>	X
--	--	--	---

	<p>Danger : Danger : Gefahr : Peligro : Pericolo : Perigo : Gevaar : ΚΙΝΔΥΝΟΣ: Niebezpieczeństwo : Vaara : Fara : Fare : Pericol :</p>	<p>Опасно : Tehlike : Nebezpečí : Nebezpečnost : Fare: خطر. Veszély : Nevarnost: Опасност : Oht Pavojus Bistamība Opasnost:</p>	X
--	--	---	---

	<p>Poids : Weight : Gewicht : Peso : Peso : Peso : Gewicht : ΒΑΡΟΣ : Masa : Paino : Vikt : Vægt : Greutate :</p>	<p>Бес : Ağrılık : Hmotnost : Hmotnosť : Vekt: الوزن. Súly : Teža : Тегло : Raskus Svoris Svars Težina</p>	12,8 kg
--	--	--	---------





 L_{pA}	Niveau de pression acoustique : Acoustic pressure level : Schalldruckpegel : Nivel de presión acústica : Livello di pressione acustica : Nivel de pressão acústica : Niveau akoestische druk : ΣΤΑΘΜΗ ΗΧΗΤΙΚΗΣ ΠΙΕΣΗΣ: Poziom mocy akustycznej : Käytä kuulosuojaimia: Ljudtrycksnivå : Lydtryk : Nivel presiune acustică :	Уровень акустического давления. : Akustik basınç seviyesi : Hladina akustického tlaku : Hladina akustického tlaku : Lydtrykknivå: مستوى الضغط السمعي. A hangnyomás szintje : Nivo akustičnega pritiska: Равнище на акустично налягане : Helirõhu tase Akustinio spaudimo lygis Akustiskā spiediena līmenis Razina zvučnog tlaka:	83,4 dB (A)
--	---	--	-------------

 L_{wA}	Niveau de puissance acoustique : Acoustic power level : Schalleistungspegel : Nivel de potencia acústica : Livello di potenza acustica: Nivel de potência acústica: Niveau akoestisch vermogen : ΕΠΙΤΕΔΟ ΙΣΧΥΟΣ ΗΧΟΥ: Poziom mocy akustycznej : Käytä suojalaseja : Ljudstyrkenivå : Lydstyrke : Nivel putere acustică :	уровень мощности звука : Akustik basınç seviyesi : Hladina zvukového výkonu: Hladina zvukového výkonu: Lydeffektivnivå: مستوى الضغط السمعي. a hangnyomás szintje : Nivo akustične jakosti : Равнище на вибрации : Helivõimsuse tase Triukšmo lygis Akustiskās jaudas līmenis Razina zvučne snage:	96,4 dB (A)
--	--	---	-------------

NIVEAU SONORE D'ÉMISSION : A VIDE

Pression acoustique LpA poste opérateur 83,4 dB
Incertitude 3

Puissance acoustique LWA 96,4 dB
Incertitude 3

Valeurs déterminées suivant le code d'essai de l'annexe B de la norme EN 61029-1 avec emploi des normes de base ISO 11201 et ISO 3744.

Les niveaux de pression acoustique obtenus in situ dépendent:

- Des niveaux réels de la machine considérées, en prenant en compte les incertitudes déclarées;
- Du local et de l'installation de la machine. Préférez une pièce dont l'acoustique est plus feutrée. Evitez les pièces vides à grande résonance. Placez vous auprès d'une fenêtre le cas échéant.
- Des outils montés, des pièces travaillées, des réglages choisis,...

 L_{vA}	Niveau de vibration : Hand/arm vibration level : Vibrationspegel Hand/Arm : Nivel de vibración mano/brazo : Livello di vibrazione mano/braccio : Nivel de vibração mão/braço : Trillingsniveau hand/arm : ΕΠΙΤΕΔΟ ΚΡΑΔΑΣΜΩΝ: Poziom wibracji rżka/ramię : Tärinätaso: Vibrationsnivå hand/arm : Vibrationsniveau : Nivel vibrații :	Уровень вибрации : Titreşim seviyesi : Úroveň vibrací : Hladina vibrácií : Vibrasjonsnivå: مستوى الارتجاج. Vibrációs szint : Nivo vibracij : Равнище : Vibrācijas līmenis. Vibrācijas lygis Vibratsiooni tase Razina vibracije:	3,86 m / s ²
--	---	---	-------------------------

VIBRATIONS:

Total des valeurs de vibration (somme vectorielle des trois directions) déterminée selon EN 60745 :

a 3,86 m/s²
Incertitude K 1,5 m/s²

L'amplitude d'oscillation peut être utilisée comme valeur de comparaison d'outils électroportatifs.
Attention : si l'outil électroportatif est utilisé pour d'autres applications, avec d'autres outils de travail, l'amplitude d'oscillation peut être différente.







	<p>Soumis à recyclage Subjected to recycling Sujeto a reciclaje Sottoposti a riciclaggio Sujeitos à reciclagem Não deite no lixo : Niet wegwerpen : ΥΠΟΚΕΙΤΑΙ ΣΕ ΑΝΑΚΥΚΛΩΣΗ Nie wyrzucac : Älä heittää pois luontoon : Batteriet får inte kastas : Bortkast det ikke: Nu le auncati :</p>	<p>Подлежит переработке Atmayiniz : Nevyhadzujte je do bežného odpadu : Neodhadzovat : Gjenvinningspliktig فلا تدرمها ملذفا في القمامة. ne mečíte1 Ne odvržite ga/jih vstran : Taaskasutusse kuuluu Ärge visake seda minema : Nemétykíte : Nemest : Podvrgnuto recikliranju</p>	X
---	---	---	---

Recyclage des déchets :

Les outils, accessoires et leur emballages doivent suivre une voie de recyclage adaptée. Conformément aux directives Européenne 2012/19/UE et 2006/66/CE, les composants d'un produit doivent être séparés, collectés, recyclés ou éliminés en conformité avec les réglementations environnementales en vigueur. Les appareils, batteries, piles, huiles, emballages devront être déposés dans les systèmes d'élimination des déchets spéciaux tels que déchetteries. Renseignez-vous auprès de votre commune pour connaître l'organisme le plus proche à même de retraiter ou de collecter ces déchets.

	<p>Recyclable, soumis au tri sélectif Recyclable, subject to recycling Recyclingfähige, unterliegen Recycling Reciclables, sujetos a reciclaje Riciclabili, soggetti a riciclaggio Recicláveis, sujeito à reciclagem Recycleerbare, onderworpen aan recycling ΑΝΑΚΥΚΛΩΣΙΜΟ, ΥΠΟΚΕΙΤΑΙ ΣΕ ΕΠΙΛΕΚΤΙΚΗ ΔΙΑΛΟΓΗ Opakowanie nadaje się do recyklingu podlegają recyklingu Kierrätettävien pakkausten kohteena kierrätys Återvinningsbara förpackningar omfattas återvinning Рециклираци се опаковки подлежат на рециклиране Genanvendelig underlagt genbrug</p>	<p>Reciclabile sub rezerva reciclare Повторно упаковка подлежит вторичной переработке Geri dönüştürülebilir ambalaj konusu Recyklovateľné podléhající recyklaci Recyklovateľné podliehajúce recyklácii Resirkulerbar, med förbehold om selektiv sortering ريودنلا هذا عال يضرخت ريودنلا هذا عال قلاباقل فصول نخل او قوب ييدلا Újrahasznosítható csomagolás alá újrahasznosítás Reciklirati predmet recikliranja Pakendite suhtes ringlussevõtu Pārstrādājams iepakojumš otrreizējai pārstrādei Perdirbamų taikomos perdirbimo Može se reciklirati, podložno selektivnom sortiranju</p>	X
---	--	--	---

	<p>Ne pas approcher les mains Keep hands at a distance No acercar las manos Não aproximar as mãos Non avvicinare le mani</p>	X
--	--	---

	<p>Maintenir les pieds à une distance de sécurité Keep feet at a safe distance Mantener los pies a una distancia de seguridad Manter os pés a uma distância de segurança Tenere i piedi a distanza di sicurezza</p>	X
---	---	---





	<p>Maintenir les enfants et les personnes présentes à l'écart pendant l'utilisation de l'outil. Keep children and other people well away from you when you are using the tool. Mantener a los niños y a las personas presentes apartados durante la utilización de la herramienta. Durante l'uso dell'attrezzo allontanare i bambini e le persone presenti. Manter as crianças e demais pessoas presentes à distância durante a utilização da ferramenta. Kinder und sonstige anwesende Personen während der Arbeit vom Werkzeug entfernt halten. Houd kinderen en anderen uit de buurt terwijl u het gereedschap gebruikt.</p> <p>Κρατήστε μακριά τα παιδιά και τους ανθρώπους που είναι παρόντες κατά την διάρκεια της χρησιμοποίησης του εργαλείου. Dzieci i inne osoby powinny przebywać w bezpiecznej odległości w czasie użytkowania narzędzia. Pidá lapset ja muut ihmiset loitolla käyttäessäsi laitetta. Med uporabo orodja naj se otroci in prisotne osebe nahajajo stran od le-tega. Держите детейта и присъстващите лица на разстояние при използване на инструмента. Hold børn og tilskuere på afstand, mens værktøjet bruges. Tínejtí la distanťa copiii și persoanele prezente în timpul utilizării aparatului. Дети и прочие присутствующие лица, должны находиться на расстоянии от работающего инструмента. Aletin kullanimi esnasında çocukları ve etrafta bulunan kişileri aletin kullanıldığı alandan uzak tutun. Počas používania nástroja udržujte deti a prítomné osoby v dostatočnej vzdialenosti. יש להרחיק הציידה ילדים ואנשי מהנוכחים בעת שימוש בכלי זה. منتجات الأدوات الكهربائيه فترات يجلن أن تستخدم في اشغال الارتفاع أو لرخ ان Az eszköz használata közben tartsa távol a gyermekeket és a jelen levő személyeket. Počas používania nástroja udržujte deti a prítomné osoby v dostatočnej vzdialenosti. Hoolitsege laste ja teiste seadmele lähedalviibivate isikute ohutuse eest. Uzmaniet bērnu un personas, kas atrodas ieslēgtu elektroierīču tuvumā. Pasirūpinti vaikai ir asmenimis esančiais šalia veikiančio prietaiso.</p>	<p>X</p>
---	---	----------

	<p>Des cordons endommagés ou emmêlés augmentent le risque de choc électrique. Damaged or twisted flexes increase the risk of electric shocks. Beschädigte oder verknottete Kabel erhöhen die Stromschlaggefahr. Cordones deteriorados o enredados aumentan el riesgo de choque eléctrico. Dei cavi danneggiati o annodati aumentano il rischio di shock elettrico. Een beschadigd of verward snoer vergroot het gevaar op elektrische schok.</p> <p>Τα φθαρμένα ή μπερδεμένα καλώδια αυξάνουν τον κίνδυνο ηλεκτροπληξίας. Uszkodzone lub zaplątane przewody zwiększają ryzyko porażenia prądem. Vahingoituneet ja sotkeentuneet johdot lisäävät sähköiskun vaaraa. Poškodovani ali zapleteni kabli povečujejo tveganje elektrošoka. Повреждени или заплетени кабели повишават риска от токов удар. Beskadigede eller sammenfiltrede ledninger forøger risikoen for elektriske stød. Cablurile deteriorate sau încalcite cresc riscul de electrocutare. Поврежденные или спутанные электрические шнуры увеличивают риск подвергнуться удару электрическим током. Hasar gören veya dolaşan kablolar elektrik çarpması riskini artırır. Poškozené nebo zamotané kabeľy zvyšujú riziko elektrického šoku. Poškodene, alebo zamotané napájacie šnúry zvyšujú riziko elektrického šoku. פתלים שניוקו או מסובכים זה בזה עלולים להגדיל את הסכנה למכת חשמל. تزيد الأسلاك الكهربائيه الجملفة أو الجمشعب ة من خطر صدمة كهربائيه A sérült vagy összegabalyodott kábelek növelik az áramütés veszélyét. En skadad eller trasslig sladd ökar risken för elstöt Riknened u viġastatud toitejuhtmed võivad põhjustada elektriööke ja lühiühendusi. Sabojati vai samudžināti vadī palielina elektrības issavienojuma risku. Pažeisti ar supainioti laidai didina trumpojo elektros jungimo riziką.</p>	<p>X</p>
---	---	----------

	<p>Ne pas exposer la machine à la pluie : Do not expose the machine to rain : Maschine nicht Regen aussetzen : No exponer la máquina a la lluvia : Non esporre lo macchinario alla pioggia : Năo expor a máquina à chuva : Stel het machine niet bloot aan regen : Μην εκτίθετε το εργαλείο στη βροχή : Nie należy wystawiać urządzenia na deszcz: Älä altista laitetta sateelle : Utsätt inte maskinen för regn : Maskinen må ikke udsættes for regn eller benyttes på våde steder Ärge jätke seadet vihma kätte. Ärge kasutage seadet niiskes kohas</p>	<p>Nepalikti įrenginio lietuje. Nenaudoti įrenginio drėgnose vietose Nenovietot metināmo aparātu zem lietus. Nelietot metināmo aparātu mitrās vietās Nu expuneți mașina la ploaie : Защитять аппарат от дождя. Ne Makineyi yağmura maruz bırakmayın : Stroj nevstavujte dešti : Nevstavujte stroj daždu : אין לחשוף את העמדה למשם : لا تستخدم الجهاز تحت المطر Ne tegye ki esőnek a gépet : Stroja ne izpostavljajte dežju : Не излагайте машината под дъжда :</p>	<p>X</p>
---	---	---	----------





TE 1200B

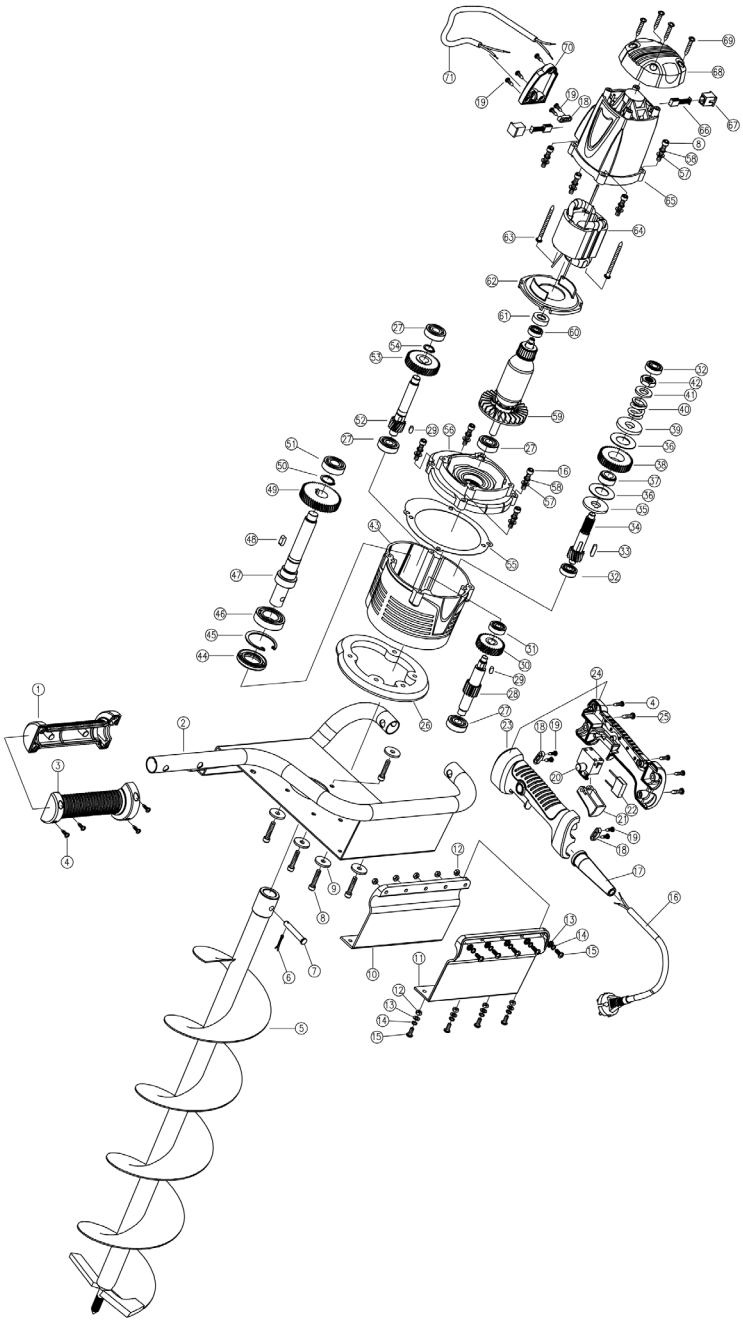

DECLARATION DE CONFORMITE
VERKLARING VAN OVEREENSTEMMING
DECLARACION DE CONFORMIDAD
DICHIARAZIONE DI CONFORMITA
KONFORMITÄSERKLÄRUNG
DECLARATION CONFORMITY
DECLARAÇÃO DE CONFORMIDADE
DEKLARACJA ZGODNOSCI Z NORMAMI
OM ÖVERENSSTÄMMELSE
VAATIMUSTENMUKAISUUSVAKUUTUS
OVERENSSTEMMELSESERKLÆRING
ΔΗΛΩΣΗ ΣΥΜΜΟΡΦΩΣΗΣ

DECLARAȚIE DE CONFORMITATE
VYHLÁSENIE ZHODY
Декларация соответствия
SAMSVARERKLÆRING
Uygunluk beyanı
التصديق بالطابق
PROHLÁŠENÍ SHODY
EGYEZŐSÉGI NYILATKOZAT
Декларация за съответствие с нормите
IZJAVA O SKLADNOSTI
DEKLARACIJA
ATITIKTIES DEKLARACIJA
KINNITUS
IZJAVA O SUKLADNOSTI

Le soussigné,
Ondergetekende,
Der Unterzeichner,
O abaixo assinado,
Undertecknad,
Долуподписаният
Undertegnede
Subseminatul,
Я, нижеподписавшийся,
Imzalayan,
Niže podepsány,
Toliau pasirašęs

Personne autorisée à constituer
le dossier technique :
Christophe HUREL



FAR GROUP EUROPE
192, Avenue Yves Farge
37700 St. Pierre-des-Corps
FRANCE

El suscrito,
Il sottoscritto,
The undersigned,
Ninej podpisany
Allékirjoittanut,
Ο ΚΑΤΩΘΙ ΥΠΟΓΡΑΜΜΕΝΟΣ,
Nižšie podpisany
Undertegnede,
الذوق ع أدناه
Alulírott,
Podpisani,
Apakšā parakstījis
allakirjutanu
Dolje potpisani,

Declara por la presente que,
Dichiare che,
Declares that,
Oświadczam niniejszym, że
Ilmoitetaan täten että,
ΔΙΑ ΤΟΥ ΠΑΡΟΝΤΟΣ ΔΗΛΩΝΕΙ ΟΤΙ,
tymto vyhlasuje, že
Erklærer herved at,
يصرح اسجدادا على ذلك
kijelentem, hogy a készülék Izjavlja da,
Pareiskia, kad,
Ar šo apliecinā, ka,
Kinnitab, et
izjavljuje u ovom dokumentu da je

Déclare par la présente que,
Verklaart hiermede dat,
Erklärt hiermit daß,
Declara pela presente que,
Förklarar härmed att
Заявляя с настоящего
erklærer hermed, at
Declara prin prezenta că,
настоящим подтверждаю, что
Mevcut belgeyle beyan ediliyor ki,
tımto prohlasuje, že,
Pareiskia, kad,

Tarière électrique / Power auger / Macht auger / De barrena / Cocola di alimentazione / Poder auger /
Power vijzel / ДУНАМН ТРУПАНИ / Moc ślimaka / Teho Auger / Ström skruv / мощность шнека / Ström snegl /
Puterea de melc / мощность буржу / Güç burju / Výkon šnek / Výkon slímák / التردد الجول / ريچو۱ قطنسلا /
Elektromos fűró / Moč sveder / Võim puuri / Jauda svärpstš / Galia sraigtas

code

FARTOOLS / 175305 / TE 1200B / EGA-1200F

Est conforme et satisfait aux directives et normes CE,
In overeenstemming is met en Voldoet aan EG richtlijnen,
Den folgenden EU-Bestimmungen entspricht,
Respeita e está em conformidade com as normas CE,
Överensstämmer med och uppfyller EG-standarder,
Съответства и отговаря европейските норми
Er i overensstemmelse med og overholder EU standarderne
Este conform și satisface normele CE
полностью соответствует и удовлетворяет
требованиям стандартов ЕС
CE şartlara uygundur,
odpovídá normám ES.
Atitinka ir atitinka EB direktyvas ir standartus,

Cumple con la directivas de la CE,
E conforme alle direttive CEE,
Complies with the EEC directives and standards,
Odpowiada normom UE,
Täyttää EU-vaatimukset,
ΣΥΜΜΟΡΦΩΝΕΤΑΙ ΚΑΙ ΙΚΑΝΟΠΟΙΕΙ ΤΙΣ ΟΔΗΓΙΕΣ ΚΑΙ ΤΑ ΠΡΟΤΥΠΑ CE,
zodpovedá normám ES.
Samsvarer med og tilfredsstiller CE-direktiver og standarder,
بان الوجود بالطابق و يالبي معايير مجموعة الدول الأوروبية
kielegíti a CE szabványok előírásait.
Je v skladu z in izpolnjuje norme Evropske skupnosti.
Atbilst un atbilst EK direktivas un standartus,
Vastab ja vastab EU direktiividele ja standarditele,
Sukladan i ispunjava direktive i standarde CE,

2006/42/EC, 2014/30/EU, 2011/65/EU 2015/863/EU 2000/14/EU
EN 60335-1:2012+A11:2014+A13:2017+A1:2019+A2:2019+A14:2019+A15:2021
EN ISO 12100:2010
EN IEC 55014-1:2021
EN IEC 55014-2:2021
EN IEC 61000-3-2:2019+A1:2021
EN 61000-3-3:2013+A1:2019+A2:2021

Christophe HUREL,
Directeur général
31/08/2023
Fait à St. Pierre-des-Corps

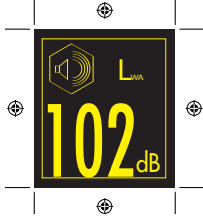

GARANTIE - WARRANTY



FR. GARANTIE

Cet outil est garanti contractuellement contre tout vice de construction et de matière, à compter de la date de vente à l'utilisateur et sur simple présentation du ticket de caisse. La garantie consiste à remplacer les parties défectueuses. Cette garantie n'est pas applicable en cas d'exploitation non conforme aux normes de l'appareil, ni en cas de dommages causés par des interventions non autorisées ou par négligence de la part de l'acheteur. La garantie ne s'applique pas sur les dommages causés par une défaillance de l'outil.

DE. GARANTIE

Die Garanzzeit für dieses Gerät in Bezug auf Konstruktions- und Materialfehler beträgt lt. Vertrag bei Vorlage des Kassensbons. Die Garantieleistung besteht im Ersatz schadhafter Teile. Die Garantie erlischt bei einem Einsatz des Geräts, der nicht normentsprechend ist, bei Schäden, die auf unsachgemäße Eingriffe zurückzuführen sind bzw. bei Nachlässigkeit seitens des Käufers. Die Garantie erstreckt sich nicht auf Schäden, die auf Fehlfunktionen des Geräts zurückzuführen sind.

IT. GARANZIA

Quest' attrezzo è garantito per contratto contro qualsiasi difetto di costruzione e di materia, a partire dalla data di vendita all' utente e su semplice presentazione dello scontrino. La garanzia consiste nel sostituire le parti difettose. Questa garanzia non è applicabile in caso di sfruttamento non conforme alle norme dell' apparecchio, né in caso di danni causati da interventi non autorizzati o da negligenza da parte dell' acquirente. La garanzia non si applica ai danni causati da un' avaria dell' attrezzo.

EN. GARANTIE

This tool is guaranteed, in writing, against any defect in manufacture of parts from the date of sale, upon simple presentation of the sales slip. The guarantee is limited to the replacement of faulty parts. This guarantee is not applicable in the event of usage which is not conform with the intended usage of the apparatus, nor in the event of damage caused by unauthorised servicing or negligence on behalf of the purchaser. This guarantee does not apply to any damage caused by

the failure of this tool.

ES. GARANTIA

Esta herramienta se garantiza contractualmente contra todo defecto de construcción y materia, a partir de la fecha de venta a l' usuario y sobre simple presentación del recibo de caja. La garantía consiste en sustituir a las partes defectuosas. Esta garantía no es aplicable en caso de explotación no conforme a las normas del aparato, ni en caso de daños causados por intervenciones no autorizadas o por negligencia por parte del comprador. La garantía no se aplica sobre los daños causados por un fallo del herramienta.

NL. GARANTIE

Dit gereedschap heeft een garantie tegen constructierouten en materiaaldefecten, die geldig is vanaf de aankoopdatum door de gebruiker, op vertoning van de kassabon. De garantie betreft de vervanging van de defecte onderdelen. Deze garantie is niet van toepassing indien het apparaat niet volgens de normen gebruikt is, noch in geval van schade veroorzaakt door oneigenlijk gebruik of nalatigheid van de koper. De garantie is niet van toepassing op schade voortvloeiend uit een defect van het gereedschap.

PT. GARANTIA

Esta ferramenta tem uma garantia contratual contra qualquer defeito de construção e de material, a partir da data de venda ao utilizador e sobre simples apresentação do talão da caixa. A garantia consiste em substituir as partes defeituosas. Esta garantia não é aplicável no caso de exploração não conforme as normas do aparelho, nem em caso de danos causados pelas intervenções não autorizadas ou por negligência da parte do comprador. A garantia não se aplica para os danos causados por uma falha da ferramenta.

EL. ΕΓΓΥΗΣΗ

ΑΥΤΟ ΤΟ ΕΡΓΑΛΕΙΟ ΕΙΝΑΙ ΣΥΜΒΑΤΙΚΑ ΕΓΓΥΗΜΕΝΟ ΓΙΑ ΟΠΟΙΟΔΗΠΟΤΕ ΚΑΤΑΣΚΕΥΑΣΤΙΚΟ ΚΑΙ ΥΛΙΚΟ ΕΛΑΤΤΩΜΑ, ΑΠΟ ΤΗΝ ΗΜΕΡΟΜΗΝΙΑ ΠΩΛΗΣΗΣ ΣΤΟΝ ΧΡΗΣΤΗ ΚΑΙ ΜΕ ΤΗΝ ΕΠΙΔΕΙΞΗ ΤΗΣ ΑΠΟΔΕΙΞΗΣ ΠΩΛΗΣΗΣ. Η ΕΓΓΥΗΣΗ ΣΥΝΙΣΤΑΤΑΙ ΣΤΗΝ ΑΝΤΙΚΑΤΑΣΤΑΣΗ ΤΩΝ ΕΛΑΤΤΩΜΑΤΙΚΩΝ ΕΞΑΡΤΗΜΑΤΩΝ. ΑΥΤΗ Η ΕΓΓΥΗΣΗ ΔΕΝ ΙΣΧΥΕΙ ΣΕ ΠΕΡΙΠΤΩΣΗ ΛΕΙΤΟΥΡΓΙΑΣ ΠΟΥ ΔΕΝ ΣΥΜΜΟΡΦΩΝΕΤΑΙ ΜΕ ΤΑ ΠΡΟΤΥΠΑ ΤΗΣ ΣΥΣΚΕΥΗΣ, ΟΥΤΕ ΣΕ ΠΕΡΙΠΤΩΣΗ ΖΗΜΙΑΣ ΠΟΥ ΠΡΟΚΑΛΕΙΤΑΙ ΑΠΟ ΜΗ ΕΘΟΥΣΙΟΔΟΤΗΜΕΝΕΣ ΕΠΕΜΒΑΣΕΙΣ Ή ΑΜΕΛΕΙΑ ΕΚ ΜΕΡΟΥΣ ΤΟΥ ΑΓΟΡΑΣΤΗ. Η ΕΓΓΥΗΣΗ ΔΕΝ ΙΣΧΥΕΙ ΓΙΑ ΖΗΜΙΕΣ ΠΟΥ ΠΡΟΚΑΛΟΥΝΤΑΙ ΑΠΟ ΑΣΤΟΧΙΑ ΕΡΓΑΛΕΙΟΥ.

PL. GWARANCJA

Narz dzie jest objte gwaranc-

jà na wszelkie wady konstrukcyjne i materiałowe, licząc od daty sprzedaży u użytkownika i po okazaniu paragonu kasowego. Gwarancja obejmuje wymianę cz. Aci wybrakowanych. Gwarancja nie znajduje zastosowania w przypadku u użytkowania niezgodnego z normami urządzenia, ani w przypadku szkód spowodowanych działaniami niedozwolonymi lub zaniedbaniami ze strony nabywcy. Gwarancja nie obejmuje szkód powstałych z powodu upadku urządzenia.

SV. GARANTI

Detta verktyg har en avtalsenlig garanti mot konstruktions- och materialfel, från och med tidpunkten för användarens inköp och genom uppvisning av kassakvittot. Garantin består i att ersätta de bristfälliga delarna. Denna garanti gäller inte om användningen inte motsvarar apparatens standarder, inte heller vid skador som orsakas av ej tillåtna ingrepp eller på grund av kopärens vårdslöshet. Garantin gäller inte försador som orsakats av att verktyget fungerat bristfälligt.

FI. TAKUU

Tämän laitteen takuu on voimassa sopimuskenmukaisesti kattaan kaikki rakenne- ja materiaaliiviat lukien ostopäivästä kassakuittia vastaan. Takuu sisältää viallisten osien korvaamisen. Takuu ei korvaa ohjeidenvastaisista käyttöä eikä välttämättömien henkilöiden käsittelystä tai ostajan huolimattomuudesta aiheutuneita vahinkoja. Takuu ei vastaa myöskään toimintavälineistä aiheutuneita vahinkoja.

BU. Гаранция

Този инструмент е под договорна гаранция срещу всякакъв дефект в изработката и използваните материали, считано от датата на продажба на потребителя и само срещу представяне на касовата бележка. Гаранционното обслужване се състои в замяна на дефектните части. Настоящата гаранция не е валидна когато апаратът се използва по начин, несъответстващ на стандарта за работа с него, както и в случай на щети, нанесени от неоторизирани лица, или вследствие на проведена небрежност от страна потребителя.

Гаранцията не покрива щети, произтекли вследствие на техническа неизправност на апарата.

DA. GARANTI

Dette værktøj er dækket af en garantikontrakt for konstruktions- og materialfejl, som gælder fra købsdatoen ved visning af kassebonen. Garantien består i at udskifte de defekte dele. Garantien dækker ikke fejl opstået som følge af anvendelse, som ikke overholder standarderne for apparatet, eller

SERVICE APRÈS VENTE - AFTER SALE SERVICE

FARGROUP EUROPE - 192, Avenue Yves Farge - 37700 St. Pierre-des-Corps - FRANCE

fargroup@fargroup.net

GARANTIE - WARRANTY



skader opstået ved ikke autoriserede indgreb eller sløsethed fra brugerens side. Garantien dækker ikke skader opstået, fordi værktøjet har svigtet.

RO. GARANTIE

Acest aparat este garantat din punct de vedere contractual împotriva tuturor viciilor de construcție și de material, începând de la data vânzării lui către utilizator și la simpla prezentare a bonului de casă. Garanția constă în înlocuirea componentelor defecte. Această garanție nu se aplică în cazul exploatarii în alt mod decât cel recomandat de normele aparatului și nici în caz de stricăciuni provocate de intervenții neautorizate sau prin neglijența cumpărătorului. Garanția nu se aplică asupra pagubelor cauzate de o defectare a aparatului.

RU. ГАРАНТИЯ

Данное изделие обладает имеющей, силу контракта гарантией, покрывающей все возможные дефекты изготовления и материала. Гарантия вступает в силу с даты продажи изделия пользователю, для этого достаточно сохранить и предъявить полученный в кассе Чек. Гарантия обязывает изготовителя заменить дефектные части изделия. В случае не соответствующего нормам использования изделия, несанкционированного демонтажа или ремонта или небрежного обращения действие гарантии прекращается. Гарантия не покрывает ущерба, возникшего в результате сбоев в работе изделия.

TU. GARANTI

Bu arac, satis tarihinden itibaren, kullanıcının sâdece vezne alindisini sunmasyyla tum uretim ve malzeme hatasina karsi garantilidir. Garanti eksik olan kisimlari degistirmek icindir. Bu garanti aracin sartlarina uygun olmayan isleme durumunda, izin verilmeden kullanimlardan kaynaklanan hasarlarda veya alicinin istegi durumunda uygulanmaz. Garanti malzemenin bir eksikliginden meydana gelen bir zararda uygulanmaz.

CS. ZÁRUKA

Pro tento nástroj platí smluvní záruka na všechny výrobní a materiálové vady od data prodeje uživateli a na základě předložení pokladního bloku. Záruka spočívá ve výměně vadných částí. Tato záruka neplatí v případě použití přístroje, které neodpovídá normám, ani v případě

škod způsobených nepovolenými zásahy nebo nedbalostí ze strany kupujícího. Záruka se nevztahuje na škody způsobené zavadou nástroje.

SK. ZÁRUKA

Pre tento nástroj platí zmluvná záruka na všetky výrobné a materiálové chyby od dátumu predaja užívateľovi a na základe predloženia pokladničného bloku. Záruka spočíva vo výmene chýbných častí. Táto záruka neplatí v prípade použitia prístroja, ktoré hezodpovedá normám, ani v prípade škod spôsobených nepovolenými zásahmi alebo nedbalosťou zo strany kupujúceho. Záruka sa nevztahuje na škody spôsobené poruchou nástroja

AR. الضمان

على مجرد تقديم بطاقة الشراء يتدخل عن تاريخ البيع الي المستهلك وبين ان عيب فني التصني عوفى الجوانب، اعتبارا ان هذه الة مضمونة شعاقديا عن اي اجهاز، ول في حالة تعرضه لاشغال حالة الاستعداد غير المطابق لمعايير لى يكون هذا الضمان قابلا للتطبيق في ظل الضمان فني سبب اخل الاجزاء الاعطالة لى يطبق الضمان على الضرر الناتج عن مخرضة او فني حالة الة اهل من قبل المشتري ناتجة عن عمليات تدخل غير

HU. GARANCIA

Erre a szerszámra szerződéses garanciát vállalunk bármilyen gyártási és anyaghiba felmerülése esetére, a fogvaszító részére történt eladás napjától számítva, a pénztári blokk egyszerű felmutatása elleneben. A garancia a hibás alkatrészek cseréjére terjed ki. Ez a garancia nem érvényes, ha a készüléket nem rendeltetésszerűen használták, sem illetéktelen beavatkozások, vagy a vásárló hanyagsága okozta károk esetén. A garancia nem fedezi azokat a károkat, melyeket a szerszám hibás működése okozott.

SI. GARANCIJA

To orodje je z garancijsko pogodbo zaščiteno proti vsem napakam v izdelavi in v sestavnem materialu od datuma prodaje naprej in ta velja ob predložitvi blagajniškega računa. Garancija velja za zamenjavo delov z napako. Ta garancija ne velja za uporabo orodja, ki ni v skladu z normami, predpisanimi za omenjeno orodje in za primere okvar, ki nastanejo zaradi nedovoljenih posegov na orodju ali zaradi malomarnega rokovanja kupca. Garancija ne velja za škodo, ki jo lahko povzroci okvara orodja.

ET. GARANTII

See tööriist kuulub lepingu järgi garantiiremonti arvestades alates müümise päevast ja kassatseki alusel kasutajale koigi konstruktsioonilise materjalivigade puhul. Garantii seisneb defektsete osade välja vahetamises. See garantii ei kehti

aparaadi normide ebatavalise eiramise puhul ega ostja poolt keelatud viisil, kasutamises või hooletussejätmises tulenevate kahjude korral. Garantii ei kehti seadme defektidest põhjustatud kahjude puhul

LV. GARANTĪJA

Sis prietaisās yra uztikrinamas kaip itin geros kokybės, nuo jo pardavimo datos iki jo panaudojimo, ir jam yra suteikiamas garantinis talonas. Garantijos metu galima pakeisti atsiradusius trumplaiakius gedimus. Si garantija netaikoma esant netinkamam naudojimui ar nesilaikant reikiam šio aparato vartojimo instrukcijų, tai pat paciam virkeji ji sugadinus. Garantija taip pat netaikoma, prietaisą naudojant ne pagal paskirtį ir ji apgadinus

LT. GARANTIJA

Sim darbarikam ir liguma noteikta garantija visiem defektiem, kas saistās ar konstrukciju un materiālu, sakot ar pardošanas datumu, kad mašīnu pardot lietotājam un vienkārši uzradot kases ceku. Garantija iekļauj bojāto daļu nomaiņu. Si garantija nav derīga, ja aparāts nav lietots saskaņā ar drošības noteikumiem, ne gadijums ja bojājumi radusies nesankcionētās ietauksanas gadijuma vai arī pircēja nolaidības dēļ. Garantija nav derīga, ja bojājumi radusies darbarika defekta dēļ

HR. JAMSTVO

Ovaj alat ima ugovorno jamstvo u slučaju bilo kakvih nedostataka u konstrukciji i materijalu, od datuma prodaje korisniku uz jednostavno predocenje racuna. Jamstvo se sastoji u zamjeni neispravnih dijelova. Ovo se jamstvo ne primjenjuje u slučaju uporabe i eksploatacije koja nije sukladna standardima uređaja, niti u slučaju štete uzrokovane neovlaštenim intervencijama ili nemarom kupca. Jamstvo se ne primjenjuje na štetu uzrokovanu nekim nedostatkom alata.

SERVICE APRÈS VENTE - AFTER SALE SERVICE

FARGROUP EUROPE - 192, Avenue Yves Farge - 37700 St. Pierre-des-Corps - FRANCE

fargroup@fargroup.net





FAR GROUP EUROPE

Une société du groupe **SIGMA**

192, Avenue Yves Farge
37700 St. Pierre-des-Corps
FRANCE

fartools.com

