

FAR one® TOOLS

- FR** Tronçonneuse à disque (Notice originale)
EN Abrasive cut-off machine (Original manual translation)
DE Tremschleifmaschine (Übersetzung aus dem Original-Anleitung)
ES Tronzadora de disco (Traducción del manual de instrucciones originale)
IT Motosega a disco (Traduzione dell'avvertenza originale)
PT Serra de disco (Tradução do livro de instruções original)
NL Afsteekbank met Slijpmachine (Vertaling van de originele instructies)

EL Αλυσοπρίνο (αρχική εγγραφή)

- PL** Przecinarka tarczowa (Tłumaczenie z oryginalnej instrukcji)
FI Katkaisusaha (Käännös alkuperäisestä ohjeet)
SV Kapsåg (Översättning från originalinstruktioner)

- BU** Машина за рязане с диск (Превод на оригиналната инструкция)
DA Skæremaskine med skive (Oversættelse fra oprindelige brugsanvisning)
RO Ferăstrău cu disc (Traducere din instructiunile originale)
RU Дисковый обрезной станок (Перевод с оригинальной инструкции)

- TU** Profil kesme makinesi (Orijinal talimatlar çeviri)
CS Kotoučová prořezávací pila (Překlad z originálního návodu)
SK Kotúčová prerezávací píla (Preklad z originálneho návodu)

- HE** תווירוקם תוארוהם סוגרת) תבריג אנלי
AR آلة لص أل تا ميل عتال نم قم جرتال حوزو إنكليزي

- HU** Fémvágógép (Fordítás az eredeti utasítások)
SL Rezalna žaga za kovine (Prevod iz izvornih navodil)
ET Ketaslõikur (Tõlge originaal juhiseid)

- LV** Diskinēs pjaustomosios staklēs (Tulkojumā no instrukcijas oriģinālvalodā)
LT Diska motoržąjis (Vertimas iš originalių instrukcijas)
HR Lančana pila (izvorni zapis)



TDS 2000C Simple Machine



© FAR GROUP EUROPE

115503-3-H-20190310

www.fartools.com



FIG. A

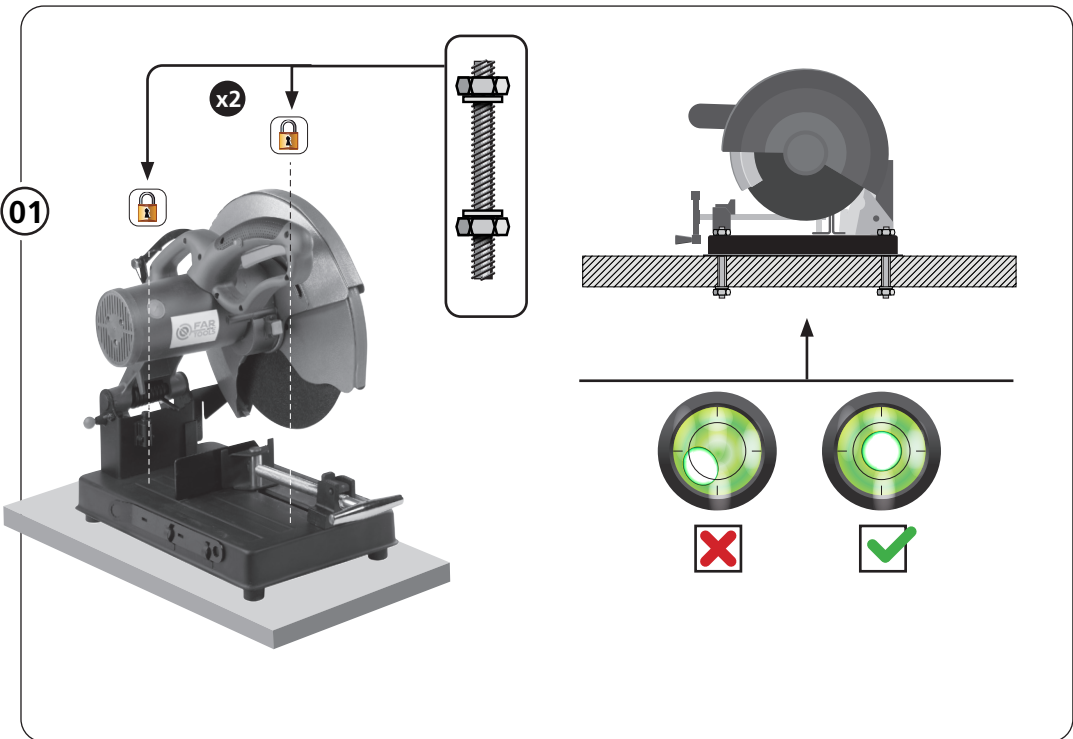
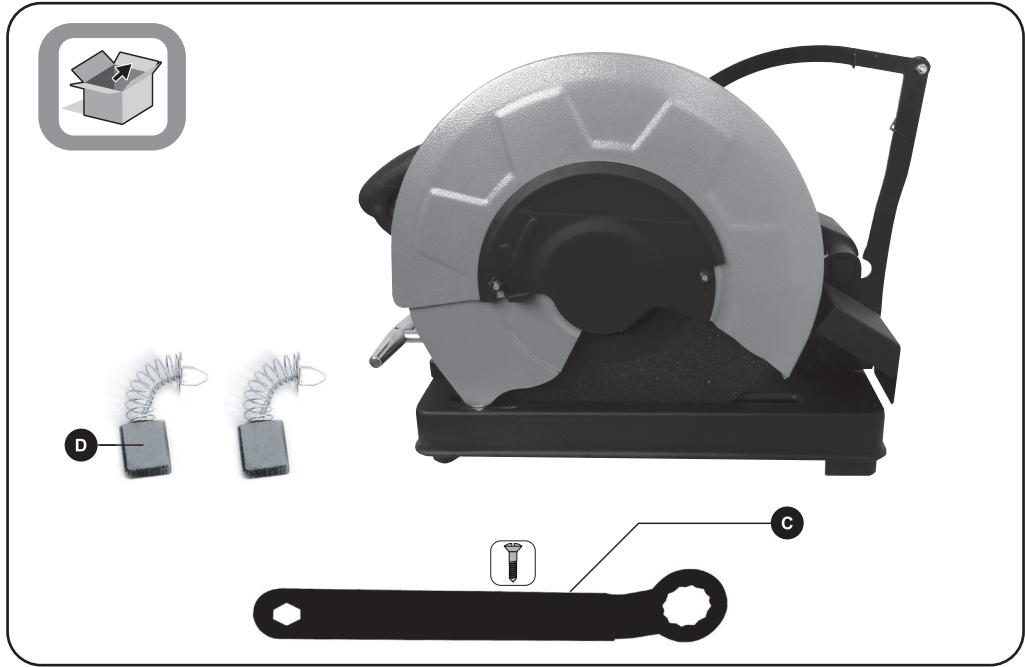



FIG. B

01

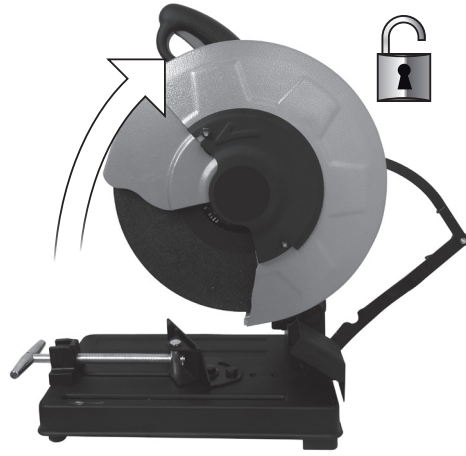
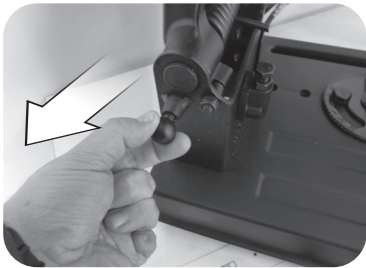
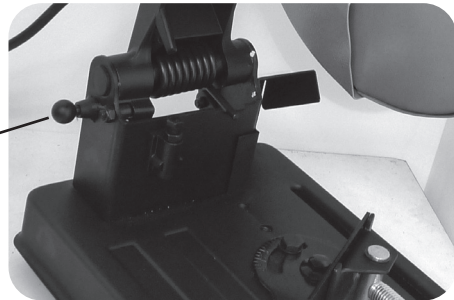
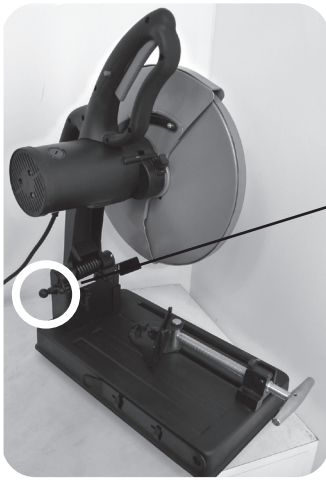
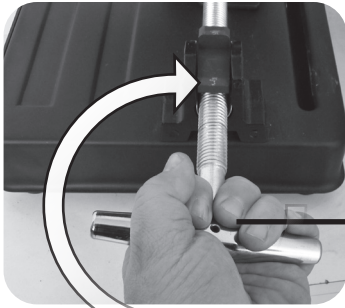
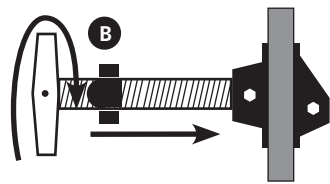
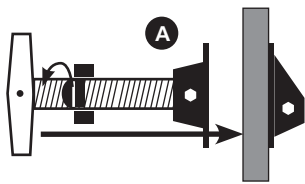
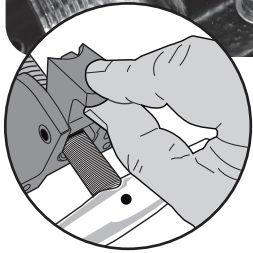
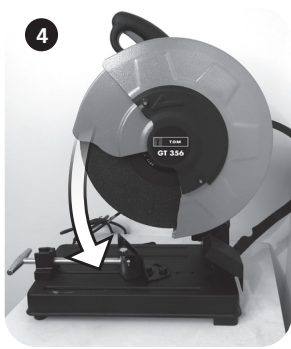
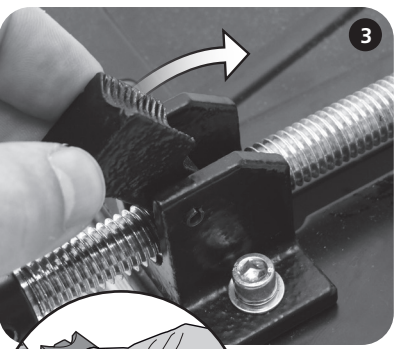
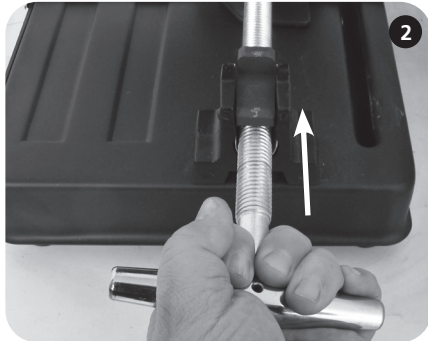
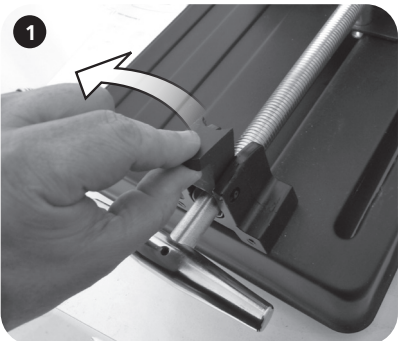



FIG. B

02





02

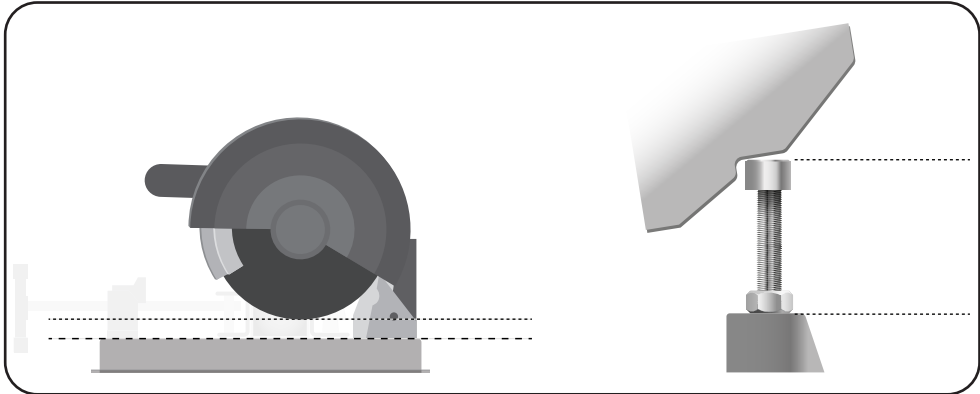
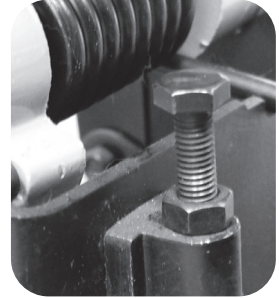
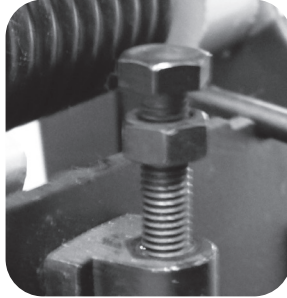
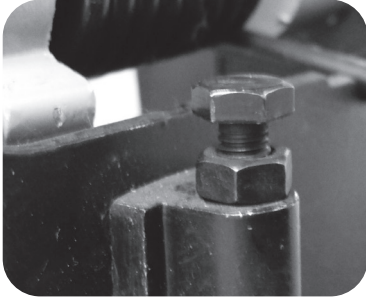
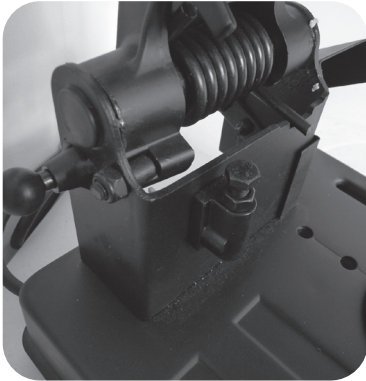
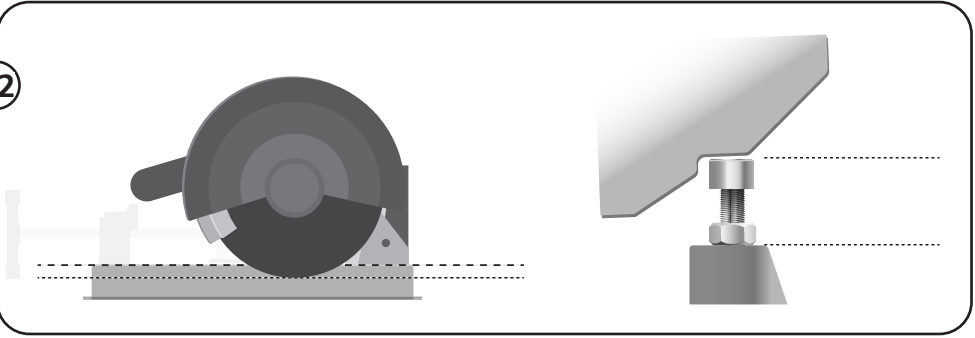



03

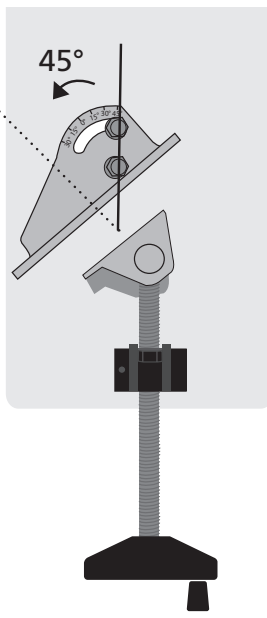
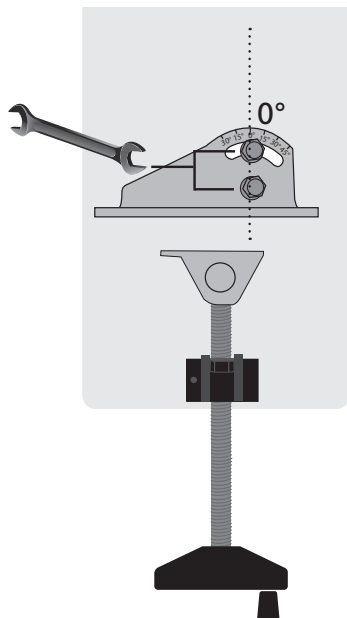
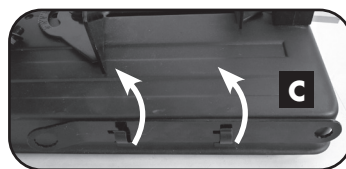
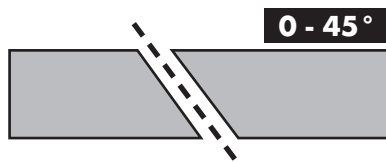
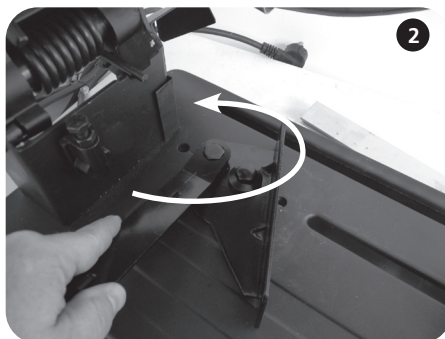
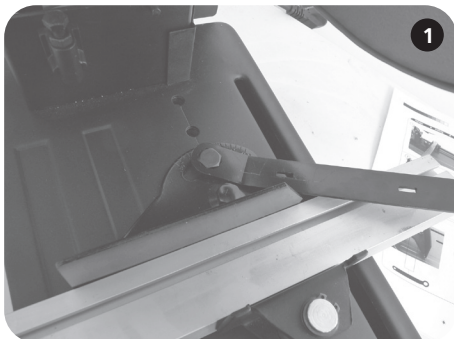



04

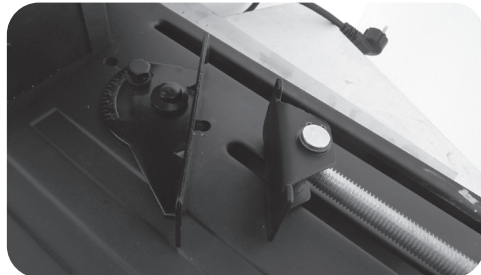
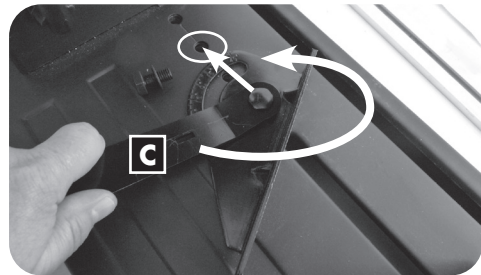
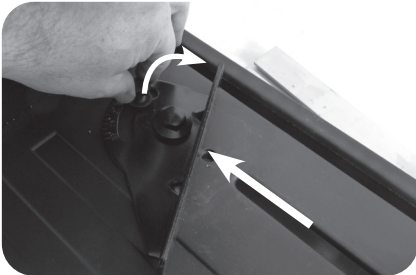
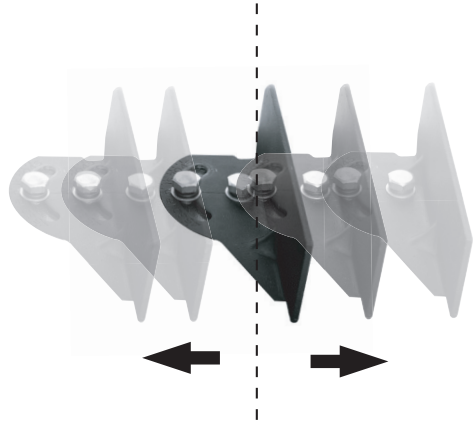
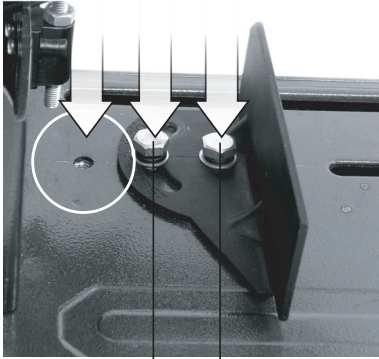



FIG. E

01

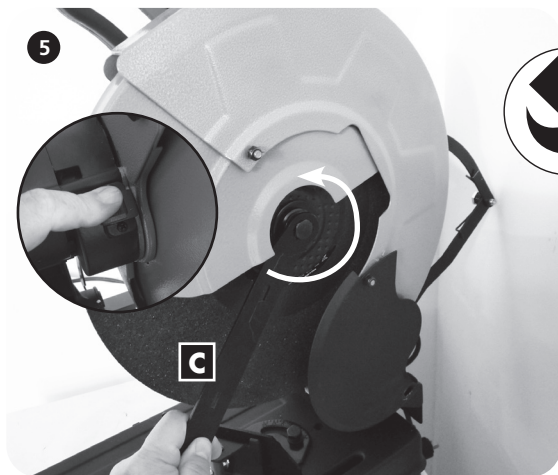
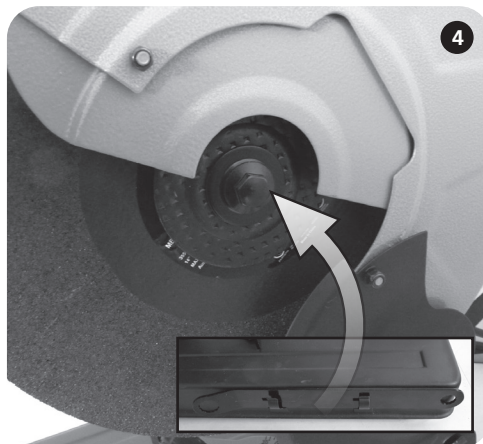
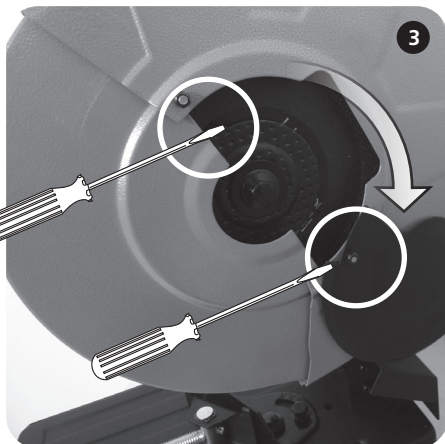
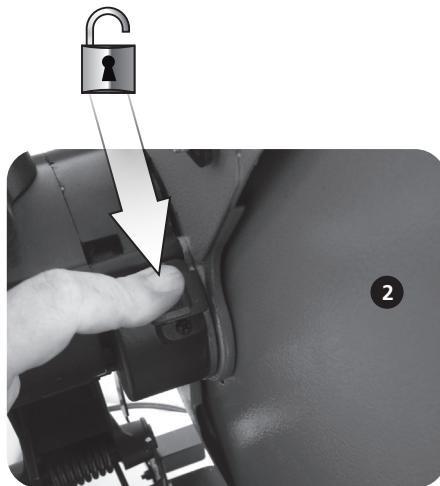
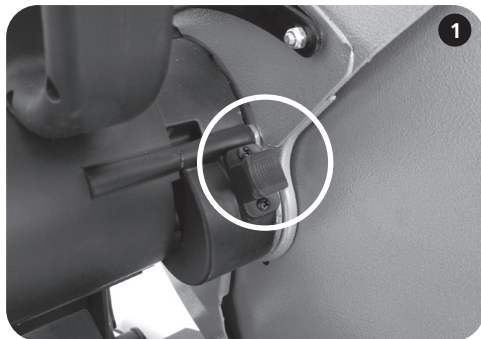
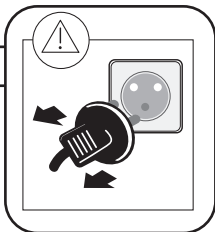
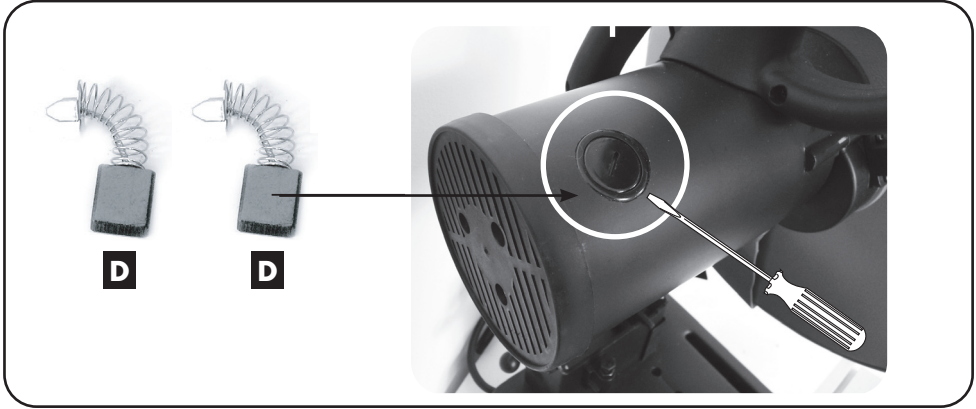
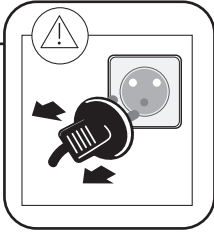

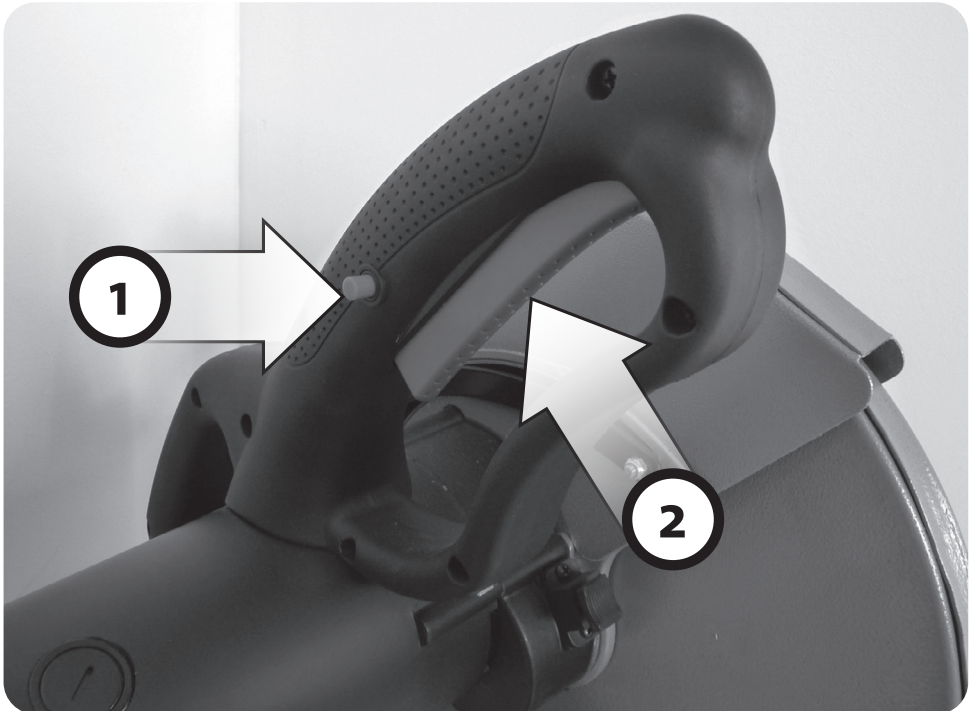

FIG. E





02



03







	<p>Tension et fréquence assignée: Nominal frequency and power: Spannung und Frequenz: Tensión y frecuencia fijada: Tensione e frequenza assegnata: Tensão e frequência fixa: Aangegeven spanning en frequentie: Ονομαστική τάση και συχνότητα: Napięcie i częstotliwość przydzielona: Jännite ja määrittäty taajuus: Angiven spänning och frekvens: Anført spænding og frekvens: Tensiune și frecvență de lucru:</p>	<p>Заданное напряжение и частота: Tahsis gerilimi ve frekansı: Stanovené napětí a frekvence: Stanovené napätie a frekvencia: מחצת ותדר מוקצב. الفصلطوية والذئذبذبة الجبرمجة Névleges feszültség és frekvencia: Napetost in določena frekvenca: Консумирано напрежение и честота : Määratud pinge ja sagedus Nustatytą įtampa ir dažnis Noteiktais spriegums un frekvence. Napon i nazivna frekvencija:</p>	230 V ~ 50 Hz
	<p>Puissance assignée: Nominal power: Leerlaufdrehzahl: Potencia fijada: Potenza assegnata: Potência assinada: Onbelast toerental: Ονομαστική ισχύς : Prędkość na biegu jałowym: Teho: Angiven effekt: Anført styrke: Putere de lucru:</p>	<p>Заданная мощность: Tahsis edilen güç: Stanovený výkon: Predpísaný výkon: כוח מוקצב. القدرة الجبرمجة Névleges teljesítmény : Določena jakost: Консумирана мощност: Määratud võimsus. Nustatytą galia Noteiktā jauda Nazivna snaga:</p>	2000 W
	<p>Classe d'isolement : 2 Insulation class : 2 Isolierung klasse : 2 Aislamiento clase :2 Isolamento classe :2 Isolamento classe :2 Isolatie Klasse : 2 Εργαλειο τάξη : 2 Izolacja Klasy :2 Eristysluokka :2 Isolering Klass :2 Isoleringsklasse 2 Clasă izolație :2</p>	<p>Класс изоляции 2 : Yalıtım derecesi :2 Třída izolace :2 Izolačný systém 2 סוג בידוד 2. فئة العزل 2. Szigetelési osztály :2 Razred izolacije :2 Инструмент Класс :2 Isolatsiooniklass 2 Izolācijas rūšis 2 Izolācijas klase 2 Izolacija klasa: 2</p>	X
	<p>Vitesse à vide: No-load speed: Drehzahl unbelastet: Velocidad vacía: Velocità a vuoto: Velocidade no vazio: Leerlaufdrehzahl: Ταχύτητα στο κεν'ο: Prędkość bez bciążenia: Tyhjäkäyntinopeus Tomgångshastighet: Hastighed i ubelastet tilstand: Viteza în gol:</p>	<p>Скорость вращения на холостом ходу: Boşalma hızı: Rychlost naprázdno: Rýchlost' pri chode naprázdno: מהירות ריק. السرعة على الفارغ. Üres sebesség: Prosti tek: Скорост на празни обороти: Kiirus tühikäigul Tuščio prietaiso greitis Tukšgaitas ātrums Brzina praznog hoda:</p>	3000 min⁻¹





 L_{pA}	Niveau de pression acoustique :	Уровень акустического давления. :	94,3 dB (A)
	Acoustic pressure level :	Akustik basınç seviyesi :	
	Schalldruckpegel :	Hladina akustického tlaku :	
	Nivel de presión acústica :	Hladina akustického tlaku :	
	Livello di pressione acustica :	רמת לחץ אקוסטי :	
	Nível de pressão acústica :	مستوى الضغط السمعي :	
	Niveau akoestische druk :	A hangnyomás szintje :	
	Σπίθμη Θορύβου :	Nivo akustičnega pritiska:	
	Poziom mocy akustycznej :	Равнище на акустично налягане :	
	Käytö kuulosuojaimia :	Heliröhu nivoo	
	Ljudtrycksnivå :	Akustinio spaudimo lygis	
Lydtryk :	Akustiskā spiediena līmenis		
Nível presiune acustică :	Razina zvučnog tlaka:		

 L_{wA}	Niveau de puissance acoustique :	уровень мощности звука :	107,3 dB (A)
	Acoustic power level :	Akustik basınç seviyesi :	
	Schalleistungspegel :	Hladina zvukového výkonu:	
	Nivel de potencia acústica :	Hladina zvukového výkonu:	
	Livello di potenza acustica:	רמת כוח אקוסטי :	
	Nível de potência acústica:	مستوى الصوتي :	
	Niveau akoestisch vermogen :	a hangnyomás szintje :	
	Σπίθμη Ονομαστική Θορύβου :	Nivo akustične jakosti :	
	Poziom mocy akustycznej :	Равнище на вибрации :	
	Käytö suojalaseja :	Helivõimsuse nivoo	
	Ljudstyrkenivå :	Triukšmo lygis	
Lydstyrke :	Akustiskās jaudas līmenis		
Nível putere acustică :	Razina zvučne snage:		

NIVEAU SONORE D'ÉMISSION :

A VIDE

Pression acoustique L_{pA} poste opérateur
Incertitude

94,3 dB
3

Puissance acoustique L_{wA}
Incertitude

107,3 dB
3

Valeurs déterminées suivant le code d'essai de l'annexe B de la norme EN 62841 avec emploi des normes de base ISO 11201 et ISO 3744.

Les niveaux de pression acoustique obtenus in situ dépendent:

- Des niveaux réels de la machine considérées, en prenant en compte les incertitudes déclarées;
- Du local et de l'installation de la machine. Préférez une pièce dont l'acoustique est plus feutrée. Evitez les pièces vide à grande résonance. Placez vous auprès d'une fenêtre le cas échéant.
- Des outils montés, des pièces travaillées, des réglages choisis,...

 L_v	Niveau de vibration :	Уровень вибрации :	2,26 m / s²
	Hand/arm vibration level :	Titreşim seviyesi :	
	Vibrationspegel Hand/Arm :	Úroveň vibrací :	
	Nivel de vibración mano/brazo :	Hladina vibrácií :	
	Livello di vibrazione mano/braccio :	רמת תנודות	
	Nível de vibração mão/braço :	مستوى الارتجاج :	
	Trillingsniveau hand/arm :	Vibrációsztint :	
	Σπίθμη κρατσοσμών :	Nivo vibracij :	
	Poziom vibracji rżka/ramiż :	Равнище :	
	Tärinätaso:	Vibrācijas līmenis.	
	Vibrationsnivå hand/arm :	Vibrācijas lygis	
Vibrationsniveau :	Vibratsioon nivo		
Nível vibrații :	Razina vibracije:		

VIBRATIONS:

Total de valeurs de vibration (somme vectorielle des trois directions) déterminée selon EN 60745 :

a

2,26 m/s²

Incertitude K

1,5 m/s²

L'amplitude d'oscillation peut être utilisée comme valeur de comparaison d'outils électroportatifs.

Attention : si l'outil électroportatif est utilisé pour d'autres applications, avec d'autres outils de travail, l'amplitude d'oscillation peut être différente.





	<p>Porter des lunettes de sécurité : Wear protective eyewear : Schutzbrille tragen : Llevar puestas gafas protectoras : Portare de gli occhiali di sicurezza : Utilizar óculos de segurança : Draag een veiligheidsbril : Φορέστε Προστατευτικά γυαλιά : Zakładać okulary ochronne : Käytä suoja-laseja : Använd skyddsglasögon : Der skal benyttes sikkerhedsbriller : Purtați ochelari de protecție :</p>	<p>Наденьте защитные очки : Güvenlik gözlükleri takın : Používejte bezpečnostní brýle : Noste ochranné okuliare : תחייב יפקשמ ביכרהל אן חמל נזלרות וקאי.ة Viseljen védőszemüveget : Nositi zaštitna očala : Да се използват защитни очила : Kandke kaitseprille Nešioti apsauginius akinius Valkāt aizsargbrilles Nositi zaštitne naočale:</p>	X
---	---	--	---

	<p>Porter un masque anti-poussière : Wear a dust mask : Staubschutzmaske tragen : Llevar puesta una careta de protección contra el polvo : Indossare una mascherina anti-polvere : Utilizar uma máscara anti-poeira : Draag een stofmasker : χρήση προστατευτική μάσκα : Zakładać maskę przeciwpyłową Käytä pölysuojust : Bär mask mot damm : Der skal benyttes beskyttelsesmaske mod støv: Purtați mască anti-praf :</p>	<p>Наденьте респиратор : Toza karşı maske takın : Používejte masku proti prachu : Noste ochrannú masku proti prachu : קבא דגן הכסמ שובחל אן لبس قناع مراض للغبار. Viseljen porvédő maszkot Nositi zaštitno masko proti prahu: Да се използва защитна маска : Kandke tolmumaski. Dėvėti respiratorių Valkāt aizsarg masku pret putekļiem Nositi masku za zaštitu od prašine:</p>	X
---	---	---	---

	<p>Porter une protection auditive : Wear hearing protective equipment: Gehörschutz tragen: Llevar puesta una protección auditiva: Portare una protezione uditiva: Utilizar uma protecção auditiva: Draag gehoorbeschermers: Φορέστε Προστατευτικά ακουστικά Zakładać słuchawki ochronne Käytä kuulosuojaimia: Bär hörselskydd: Der skal benyttes høreværn: Purtați căști de protecție auz:</p>	<p>наденьте средства звуковой защиты: İşitsel koruma aleti takın: Používejte ochranu sluchu: Noste ochranné slúchadlá: יש ל הרכיב הגנת שמיעה لبس خوذة خرض الخرجيج Viseljen fülvédőt Nositi zašito ušes: Да се използва слухови защитни средства: Kandke kõrvakaitset Nešioti apsaugą nuo triukšmo Valkāt dzirdes aizsarglīdzekli Nositi štītnike protiv buke:</p>	X
--	--	---	---

	<p>Porter des gants : Use rubber gloves : Schutzhandschuhe tragen : Llevar guantes de protección : Indossare i guanti di protezione : Utilizar luvas de protecção : Draag veiligheidshandschoenen : χρήση προστατευτικών γαντιών : Używać rękawic ochronnych : Käytä suojakäsineitä : Använd skyddshandskar : Der skal benyttes handsker : Purtați mănuși :</p>	<p>Наденьте перчатки : Eldiven takın : Noste rukavice : Noste rukavice : תופכ שובלל אן لبس قفازات. Viseljen kesztyű t Nositi rokavice: а се използват предпазни ръкавици : Kandke kindaid Mūvēti pirštines Valkāt cimds Nositi zaštitne rukavice:</p>	X
---	---	---	---





	<p>Conformité européenne Conforms to EC standards : CE-Konformität : Cumples con las directivas CE : Conforme alle norme CE : Conforme às normas CE : Voldoet aan de EG-normen : Συμφώνο με τα πρότυπα Zgodność z normami CE : EU-standardien mukainen : EU-standardien mukainen : Overholder EU standarderne : Conform cu normele europene:</p>	<p>соответствие европейским стандартам: Avrupa uygunluk : evropská shoda : európska dohoda : התאמה לתקנים האירופיים مطابق للمواصفات الأوروبية evropska ustreznost : európai megfeleléség : Съответствие с европейските норми : Euroopa Liidu vastavusmärk Europinių normų atitikima Atbilstība Eiropas standartiem Euroopska sukladnost</p>	X
---	--	---	----------

	<p>Danger : Danger : Gefahr : Peligro : Pericolo : Perigo : Gevaar : Κίνδυνος : Niebezpieczeństwo : Vaara : Fara : Fare : Pericol :</p>	<p>Опасно : Tehlike : Nebezpečí : Nebezpečnostvo : סכנה خطر Veszély : Nevamost: Опасност : Oht Pavojus Bīstamība Опасност:</p>	X
---	---	--	----------

		ø 25,4 mm
		3,55 mm
		90° = 80x110 mm

	<p>Lire les instructions avant usage : Read the instructions before use : Vor Einsatz des Geräts Anweisung lesen : Léase las instrucciones antes de usar : Leggere le istruzioni prima dell'uso : Ler as instruções antes da utilização : Lees voor het gebruik de instructies : Διαβάστε τις οδηγίες χρήσης : Zapoznać się instrukcją przed użyciem : Lue ohjeet ennen käyttöä : Läs anvisningarna före användning : læs instruktionerne før brug Înainte de utilizare, cititi instructiunile :</p>	<p>Внимательно прочитайте следующие инструкции : Kullanmadan talimatları okuyunuz : Pozorně si přečtěte následující pokyny : Pred použitím si prečítajte pokyny : זרם הילופי اقرأ التعليمات قبل الاستخدام használat előtt olvassuk el az utasítást : Pred uporabo preberite ustrezna navodila Прочетете указанията за употреба : Enne kasutamist lugege instruksiooni Prieš naudojimą perskaityti instrukciją izlasīt instrukcijas pirms lietošanas Pročitati upute prije uporabe:</p>	X
---	--	---	----------





	<p>Soumis à recyclage Subjected to recycling Sujeto a reciclaje Sottoposti a riciclaggio Sujeitos à reciclagem Não deite no lixo : Niet wegwerpen : Μην την πετάτε : Nie wyrzucas : Älä heittä pois luontoon : Batteriet får inte kastas : Bortkast det ikke : Nu le auncati :</p>	<p>Не выбрасывайте в мусорный ящик Atmayiniz : Nevyhazujte je do bežného odpadu : Neodhadzovat : אין לזרוק סוללות فلا ترمها لهذا في القمامة. ne mečite! Ne odvržite ga/jih vstran : Не го изхвърляйте : Ärge visake seda minema : Nemétykíte : Nemest : Podvrgnuto recikliranju</p>	X
---	--	---	---

Recyclage des déchets :

Les outils, accessoires et leur emballages doivent suivre une voie de recyclage adaptée. Conformément aux directives Européenne 2012/19/UE et 2006/66/CE, les composants d'un produit doivent être séparés, collectés, recyclés ou éliminés en conformité avec les réglementations environnementales en vigueur. Les appareils, batteries, piles, huiles, emballages devront être déposés dans les systèmes d'élimination des déchets spéciaux tels que déchetteries. Renseignez-vous auprès de votre commune pour connaître l'organisme le plus proche à même de retraiter ou de collecter ces déchets.

	<p>Recyclable, soumis au tri sélectif Recyclable, subject to recycling Recyclingfähige, unterliegen Recycling Reciclables, sujetos a reciclaje Riciclabili, soggetti a riciclaggio Recicláveis, sujeito à reciclagem Recycleerbare, onderworpen aan recycling Ανακυκλώσιμες συσκευασίες που υπόκεινται σε κύκλωση Opakowanie nadaje się do recyklingu podlegają recyklingu Kierrätettävien pakkausten kohteena kierrätys Återvinningsbara förpackningar omfattas återvinning Рециклиращи се опаковки подлежат на рециклиране Genanvendelig underlagt genbrug</p>	<p>Reciclabile sub rezerva reciclare Повторно упаковка подлежит вторичной переработке Geri dönüŝüm Geri dönüŝtürülebilir ambalaj konusu Recyklovateľné podliehajúci recyklácii Recyklovateľné podliehajúce recyklácii רוחמל רווחמל הזיראה אשונ רעיונטלא האעאל געזעצט רעיונטלא האעאל האבאלאל פועל געטלאו געזעצטלא Újrahasznosítható csomagolás alá újrahasznosítás Reciklirati predmet recikliranje Pakendite suhtes ringlussevõtu Pārstrādājams iepakojumš otrreizējai pārstrādei Perdirbamų taikomos perdirbimo Može se reciklirati, podložno selektivnom sortiranju</p>	X
---	---	---	---





TDS 2000C

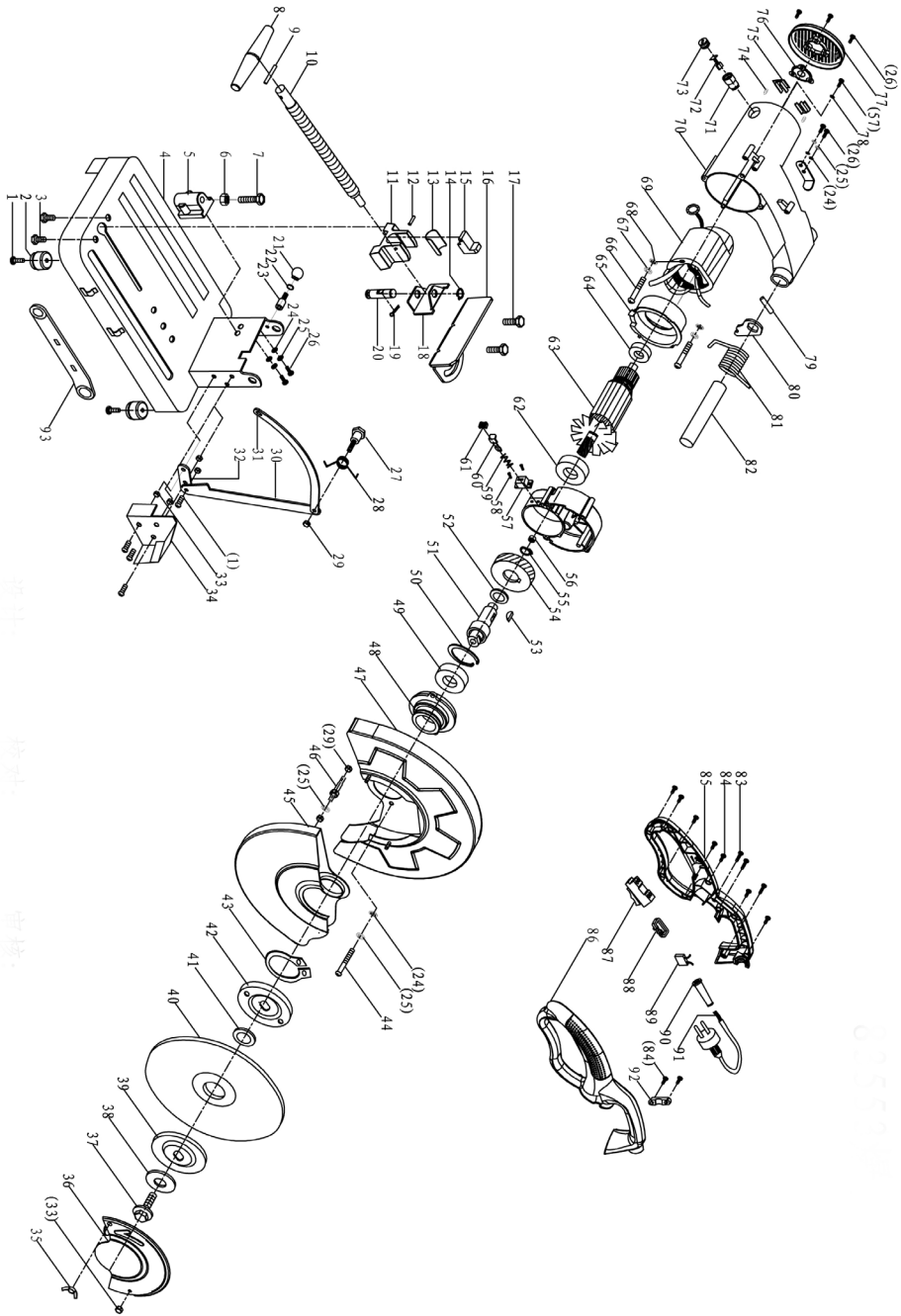

2011-11-11 14:54:11 零件图





DECLARATION DE CONFORMITE
VERKLARING VAN OVEREENSTEMMING
DECLARACION DE CONFORMIDAD
DICHIARAZIONE DI CONFORMITA
KONFORMITÄSERKLÄRUNG
DECLARATION CONFORMITY
DECLARAÇÃO DE CONFORMIDADE
DEKLARACJA ZGODNOSCI Z NORMAMI
OM ÖVERENSSTÄMMELE
VAATIMUSTENMUKAISUUSVAKUUTUS
OVERENSSTEMMELESERKLÆRING
ΔΗΛΩΣΗ ΣΥΜΜΟΡΦΩΣΗΣ

DECLARATIE DE CONFORMITATE
VYHLÁSENIE ZHODY
Декларация соответствия
SAMSVARERKLÆRING
Uygunluk beyanı
التصريح بالخطابفة
PROHLÁŠENÍ SHODY
EGYZŐSÉGI NYILATKOZAT
Декларация за съответствие с нормите
IZJAVA O SKLADNOSTI
DEKLARACJA
ATTIKTIES DEKLARACJA
KINNITUS
IZJAVA O SUKLADNOSTI

Le soussigné,
Ondergetekende,
Der Unterzeichner,
O abaixo assinado,
Undertecknad,
Долуподписаният
Undertegnede
Subsemnatul,
Я, нижеподписавшийся,
Imzalayan,
Niže podepsány,
Toliau pasirašęs

Personne autorisée à constituer
le dossier technique :
Ronan GULLIOT



FAR GROUP EUROPE
192, Avenue Yves Farge
37700 St. Pierre-des-Corps
FRANCE

El suscrito,
Il sottoscritto,
The undersigned,
Ninej podpisany
Allékirjoittanut,
Ο ΚΑΤΩΘΙ ΥΠΟΓΡΑΜΜΕΝΟΣ,
Nižšie podpisany
Undertegnede,
الموقّع أدناه
Alulírott,
Podpisani,
Apakš parakstijies
allakirjutanu
Dolje potpisani,

Declare par la présente que,
Verklaart hiermede dat,
Erklärt hiermit daß,
Declara pela presente que,
Förklarar härmed att
Заявляя с настоящото
erklærer hermed, at
Declar prin prezenta că,
настоящим подтверждаю, что
Mevcut belgeyle beyan ediliyor ki,
tımto prohlasuje, že,
Pareiskia, kad,

Declaro por la presente, que,
Dichiare che,
Declares that,
Oświadczca niniejszym, że
Ilmoitetaan täten että,
ΔΙΑ ΤΟΥ ΠΑΡΟΝΤΟΣ ΔΗΛΩΝΕΙ 'ΟΤΙ,
týmto vyhlasuje, že
Erklærer herved at,
كيعترف استنادا على ذلك
kijelentem, hogy a készülék izjavlja da,
Pareiskia, kad,
Ar šo apliecinā, ka,
Kinnitab, et
izjavljuje u ovom dokumentu da je

Abrasiye cut-off machine / Tronconneuse à disque / Tremschleifmaschine / Tronzadora de disco / Motoşega a disco / Serra de disco / Afsteekbank met Slijpmachine / Μηχανή κοπής μεσόλο κούβς / Przecznarka tarczowa / Katkaisusaha / Kapsäg / Машина за рязане с диск / Skæringsmaskine med skive / Ferüstráin cu disc / Дискотворна одрезнаюу станок / Profil kesme makinası / Kötüçová přerézávací pila / Kötüçová prerezávací pila / תבנית / Discotă / Фемвагөгөп / Rezalna žaga za kovine / Ketaslöikur / Diskinės pjaustomosios staklės / Diska motoržagis

code

FARTOOLS ONE / 115503 / TDS 2000C / JF83553

Est conforme et satisfait aux directives et normes CE,
In overeenstemming is met en voldoet aan EG richtlijnen,
Den folgenden EU-Bestimmungen entspricht,
Respeita e está em conformidade com as normas CE,
Överensstämmer med och uppfyller EG-standarder,
Съответства и отговаря европейските норми
Er i overensstemmelse med og overholder EU standarderne
Este conform și satisface normele CE
полностью соответствуют и удовлетворяют
требованиям стандартов ЕС
CE şartlara uygundur,
odpovídá normám ES.
Atitinka ir atitinka EB direktyvas ir standartus,

Cumple con la directivas de la CE,
E conforme alle direttive CEE,
Complies with the EEC directives and standards,
Odpowiada normom UE,
Täyttää EU-vaatimukset,
ΣΥΜΜΟΡΦΩΝΕΤΑΙ ΚΑΙ ΙΚΑΝΟΠΟΙΕΙ ΤΙΣ ΟΔΗΓΙΕΣ ΚΑΙ ΤΑ ΠΡΟΤΥΠΑ CE,
zodpovedá normám ES.
Samsvarer med og tilfredsstiller CE-direktiver og standarder,
بمان الـتوافق مطابفة و يـتـمـتـبـي مع مجموعة الدول الأوروبية
kijelgíti a CE szabványok előírásait.
Je v skladu z in izpolnjuje norme Evropske skupnosti.
Atbilst un atbilst EK direktivas un standartos,
Vastab ja vastab EU direktiividele ja standarditele,
Sukladan i ispunjava direktive i standarde CE,

2006/42/EC, 2014/30/EU, 2011/65/EU, 2015/863/EU

EN62841-1:2015
EN62841-3-10:2015/A11:2017
EN IEC 55014-1:2021
EN IEC 55014-2:2021
EN IEC 61000-3-2:2019/A1:2021
EN IEC 61000-3-11:2019

Ronan GULLIOT,
Directeur général
28/05/2021
Fait à St. Pierre-des-Corps



Plaques signalétiques - naamplaatjes - placas de identificación - placas de identificação - targhette - machine labels

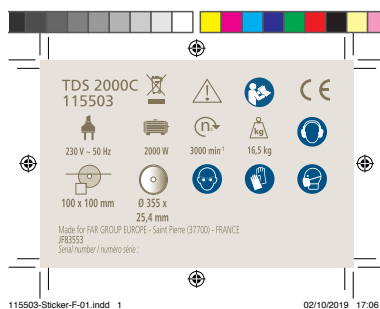
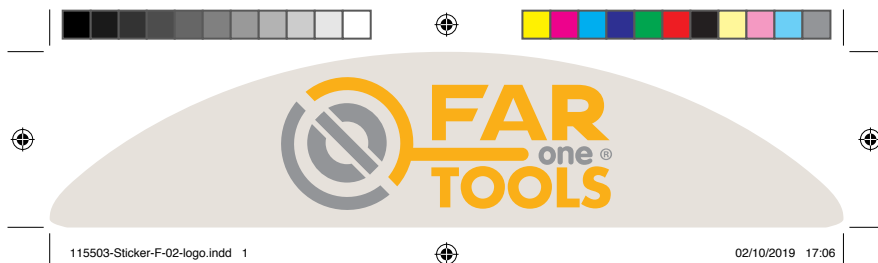

GARANTIE - WARRANTY



FR. GARANTIE

Cet outil est garanti contractuellement contre tout vice de construction et de matière, à compter de la date de vente à l'utilisateur et sur simple présentation du ticket de caisse. La garantie consiste à remplacer les parties défectueuses. Cette garantie n'est pas applicable en cas d'exploitation non conforme aux normes de l'appareil, ni en cas de dommages causés par des interventions non autorisées ou par négligence de la part de l'acheteur. La garantie ne s'applique pas sur les dommages causés par une défaillance de l'outil.

DE. GARANTIE

Die Garantiezeit für dieses Gerät in bezug auf Konstruktions- und Materialfehler beträgt lt. Vertrag bei Vorlage des Kassensbons. Die Garantieleistung besteht im Ersatz schadhafter Teile. Die Garantie erlischt bei einem Einsatz des Geräts, der nicht normentsprechend ist, bei Schäden, die auf unsachgemäße Eingriffe zurückzuführen sind bzw. bei Nachlässigkeit seitens des Käufers. Die Garantie erstreckt sich nicht auf Schäden, die auf Fehlfunktionen des Geräts zurückzuführen sind.

IT. GARANZIA

Quest' attrezzo è garantito per contratto contro qualsiasi difetto di costruzione e di materia, a partire dalla data di vendita all'utente e su semplice presentazione dello scontrino. La garanzia consiste nel sostituire le parti difettose. Questa garanzia non è applicabile in caso di sfruttamento non conforme alle norme dell'apparecchio, né in caso di danni causati da interventi non autorizzati o da negligenza da parte dell'acquirente. La garanzia non si applica ai danni causati da un'avaria dell'attrezzo.

EN. GARANTÉE

This tool is guaranteed, in writing, against any defect in manufacture or parts from the date of sale, upon simple presentation of the sales slip. The guarantee is limited to the replacement of faulty parts. This guarantee is not applicable in the event of usage which is not conform with the intended usage of the apparatus, nor in the event of damage caused by unauthorised servicing or negligence on behalf of the purchaser. This guarantee does not apply to any damage caused by the failure of this tool.

ES. GARANTÍA

Esta herramienta se garantiza contractualmente contra todo defecto de construcción y materia, a partir de la fecha de venta a l' usuario y sobre simple presentación del recibo de caja. La garantía

consiste en sustituir a las partes defectuosas. Esta garantía no es aplicable en caso de explotación no conforme a las normas del aparato, ni en caso de daños causados por intervenciones no autorizadas o por negligencia por parte del comprador. La garantía no se aplica sobre los daños causados por un fallo del herramienta.

NL. GARANTIE

Dit gereedschap heeft een garantie tegen constructiefouten en materiaaldefecten, die geldig is vanaf de aankoopdatum door de gebruiker, op vertoning van de kassabon. De garantie betreft de vervanging van de defecte onderdelen. Deze garantie is niet van toepassing indien het apparaat niet volgens de normen gebruikt is, noch in geval van schade veroorzaakt door oneigenlijk gebruik of nalatigheid van de koper. De garantie is niet van toepassing op schade voortvloeiend uit een defect van het gereedschap.

PT. GARANTIA

Esta ferramenta tem uma garantia contratual contra qualquer defeito de construção e de material, a partir da data de venda ao utilizador e sobre simples apresentação do talão da caixa. A garantia consiste em substituir as partes defeituosas. Esta garantia não é aplicável no caso de exploração não conforme às normas do aparelho, nem em caso de danos causados pelas intervenções não autorizadas ou por negligência da parte do comprador. A garantia não se aplica para os danos causados por uma falha da ferramenta.

EL. ΕΓΓΥΗΜΑ

Το εργαλείο αυτό φέρει συμβατική εγγύηση για οποιούδηποτε ελαττωμα κατασκευής από την ημερομηνία Πώλησης στο χρήστη, με απλή Προσκόμιση της, από οποιουδήποτε αγοράς. Η εγγύηση απολείται από την αντικατάσταση των ελαττωματικών τμημάτων. Η Παρούσα εγγύηση δεν εφαρμόζεται σε Περιπτώση χρήσης μη συμφωνής, με τα Πρότυπα της συσκευής, ή σε Περιπτώση ζημιάς που Προκαλήθηκε από μη εγκεκριμένη Επέμβαση ή από αμέλεια του αγοραστή. Η εγγύηση δεν εφαρμόζεται στις ζημιές που Προκαλούνται από βλάβη του εργαλείου Σταυρού κενού Διαστήματος - Περιβυσμα

PL. GWARANCJA

Narz dzie jest objte gwarancją na wszelkie wady konstrukcyjne i materiałowe, licząc od daty sprzedaży u ytkownikowi i po okazaniu paragonu kasowego. Gwarancja obejmuje wymianę cz.ści wybrakowanych. Gwarancja nie znajduje zastosowania w przypadku u ytkowania niezgodnego z normami urzadzzenia, ani w przypadku szkód spowodowanych działaniami niedoz-

wolonymi lub zamiedbaniami ze strony nabywcy. Gwarancja nie obejmuje szkód powstałych z powodu upadku urzadzzenia.

SV. GARANTI

Detta verktyg har en avtalsenlig garanti mot konstruktions och materialfel, från och med tidpunkten för användarens inköp och genom uppvisning av kassakvitto. Garantin består i att ersätta de bristfälliga delarna. Denna garanti gäller inte om användningen inte motsvarar apparatens standarder, inte heller vid skador som orsakas av ej tillåtna ingrepp eller på grund av köparens vårdslöshet. Garantin gäller inte förskador som orsakats av att verktyget fungerat bristfälligt.

FI. TAKUU

Tämän laitteen takuu on voimassa sopimuksenmukaisesti kattaaen kaikki rakenne- ja materiaaliiviat lukien ostopäivästä kassakuittia vastaan. Takuu sisältää viallisten osien korvaamisen. Takuu ei korvaa ohjeidenvastaista käyttöä eikä valtuuttamattomien henkilöiden käsittelystä tai ostajan huolimattomuudesta aiheutuneita vahinkoja. Takuu ei vastaa myöskään toimintahäiriöistä aiheutuneita vahinkoja.

BU. Гаранция

Този инструмент е под договорна гаранция срещу всякакъв дефект в изработката и използваните материали, считано от датата на продажба на потребителя и само срещу представяне на касовата бележка. Гаранционното обслужване се състои в замяна на дефектните части. Настоящата гаранция не е валидна когато апаратът се използва по начин, несъответстващ на стандарта за работа с него, както и в случай на щети, нанесени от неоторизирани лица, или вследствие на проявена небрежност от страна на потребителя.

Гаранцията не покрива щети, произтекли вследствие на техническа неизправност на апарата.

DA. GARANTI

Dette værktøj er dækket af en garantikontrakt for konstruktions- og materialefejl, som gælder fra købsdatoen ved visning af kassebonen. Garantien består i at udskifte de defekte dele. Garantien dækker ikke fejl opstået som følge af anvendelse, som ikke overholder standarderne for apparatet, eller skader opstået ved ikke autoriserede indgreb eller sløshed fra brugerens side. Garantien dækker ikke skader opstået, fordi værktøjet har svigtet.

SERVICE APRÈS VENTE - AFTER SALE SERVICE

FARGROUP EUROPE - 192, Avenue Yves Farge - 37700 St. Pierre-des-Corps - FRANCE

fargroup@fargroup.net

GARANTIE - WARRANTY



RO. GARANTIE

Acest aparat este garantat din punct de vedere contractual împotriva tuturor viciilor de construcție și de material, începând de la data vânzării lui către utilizator și la simpla prezentare a bonului de casă. Garanția constă în înlocuirea componentelor defecte. Această garanție nu se aplică în cazul exploatarei în alt mod decât cel recomandat de normele aparatului și nici în caz de stricăciuni provocate de intervenții neautorizate sau prin neglijența cumpărătorului. Garanția nu se aplică asupra pagbelor cauzate de o defectare a aparatului.

RU. ГАРАНТИЯ

Данное изделие обладает имеющей силу контракта гарантией, покрывающей все возможные дефекты изготовления и материала. Гарантия вступает в силу с даты продажи изделия пользователю, для этого достаточно сохранить и предъявить полученный в кассе чек. Гарантия обязывает изготовителя заменить дефектные части изделия. В случае не соответствующего нормам использования изделия, не санкционированного демонтажа или ремонта или небрежного обращения действие гарантии прекращается. Гарантия не покрывает ущерба, возникшего в результате сбоев в работе изделия.

TU. GARANTI

Bu araç, satış tarihinden itibaren, kullanıcının sadece vezne alıncısına summasıyla tüm üretilen ve malzeme hatasına karşı garantilidir. Garanti eksik olan kısımları değiştirmek içindir. Bu garanti aracın şartlarına uygun olmayan işleme durumunda, izin verilmeyen kullanımlardan kaynaklanan hasarlarda veya alıcının isteği durumunda uygulanmaz. Garanti malzemenin bir eksikliğinden meydana gelen bir zararda uygulanmaz.

CS. ZÁRUKA

Pro tento nástroj platí smluvní záruka na všechny výrobní a materiálové vady od data prodeje uživateli a na základě předložení pokladního bloku. Záruka spočívá ve výměně vadných částí. Tato záruka neplatí v případě použití přístroje, které neodpovídá normám, ani v případě škod způsobených nepovolenými zásahy nebo nedbalostí ze strany kupujícího. Záruka se nevztahuje na škody způsobené závadou nástroje.

SK. ZÁRUKA

Pre tento nástroj platí zmluvná záruka na všetky výrobné a materiálové chyby od dátumu predaja užívateľovi a na

základe predloženia pokladničného bloku. Záruka spočíva vo výmene chybných častí. Táto záruka neplatí v prípade použitia prístroja, ktoré nezodpovedá normám, ani v prípade škod spôsobených nepovolenými zásahmi alebo nedbalosťou zo strany kupujúceho. Záruka sa nevzťahuje na škody spôsobené poruchou nástroja

אחריות

חשבונית קופה. האחריות-משמעה מיום המכירה למשתמש עם הצגת מחל כלי ליקוי בייצור או בחומר, החל הי עלכלי זה חלה אחריות לפי חוקה נק שנגרם על ידי התערבותו תללל שאינו מתאים לתקינם ובמקרה של אינה חלה במקרה של שימוש במכשיר החלף תחלקם הלקויים אחריות זו חלה על נק שנגרם על ידי תקלה בכלי. רשלנות מאת הקונה. האחריות אינה מוכח או על ידי

الضمان

على مدار تقديم بطاقة الشراء يتغل ق تاريخ البيع الى الحسنة عمل وبناءا في التصدي عوفي الجواد. اعتبارا من الخ دة حضوره توافديا عن أي عيب في حالة تعرضه لتلفات إن هذه غير الطابق لمعاريي الجهاز. ولا فابل للتطبيق في حالة الاستخدام الأجزاء العاطلة لا يكون هذا الضمان الناتج عن خلل الضمان فاي ستبدال الحشترى لا يطبق الضمان على الضرر غير حرة أو في حالة الأملل عن قبل ذاتية عن عمليات تدل

HU. GARANCIA

Erre a szerszámra szerződéses garanciát vállalunk bármilyen gyártási és anyaghiba felmerülése esetére, a fogyasztó részére történt eladás napjától számítva, a pénztári blokk egyszerű felmutatása ellenében. A garancia a hibás alkatrészek cseréjére terjed ki. Ez a garancia nem érvényes, ha a készüléket nem rendeltetésszerűen használták, sem illetéktelen beavatkozások, vagy a vásárló hanyagsága okozta károk esetén. A garancia nem fedezi azokat a károkat, melyeket a szerszám hibás működése okozott.

SL. GARANCIJA

To orodje je z garancijsko pogodbo zaščiteno proti vsem napakam v izdelavi in v sestavnem materialu od datuma prodaje naprej in ta velja ob predložitvi blagajniškega računa. Garancija velja za zamenjavo delov z napako. Ta garancija ne velja za uporabo orodja, ki ni v skladu z normami, predpisanimi za omenjeno orodje in za primere okvar, ki nastanejo zaradi nedovoljenih posegov na orodju ali zaradi malomarnega rokovanja kupca. Garancija ne velja za škodo, ki jo lahko povzroči okvara orodja.

ET. GARANTII

See tööriist kuulub lepingu järgi garantiiremonti arvestades alates müümise päevast ja kasatšeki alusel kasutatjale kõigi konstruktsiooni- ja materjalivigade puhul. Garantii seisneb defektsete osade väljavahetamises. See garanti ei kehti aparaadi normide ebatavalise eiramise puhul ega ostja poolt keelatud

viisil kasutamisel või hooletussejätmisest tulenevate kahude korral. Garantii ei kehti seadme defektidest põhjustatud kahude puhul

IV. GARANTIJA

Sis prietaisais yra užtikrinamas kaip itin geros kokybės, nuo jo pardavimo datos iki jo panaudojimo, ir jam yra suteikiama garantinis talonas. Garantijos metu galima pakeisti atsiradusius trumplatakius gedimus. Ši garantija netaikoma esant netinkamam naudojimui ar nesilaikant reikiam šio aparato vartojimo instrukcijų, tai pat pačiam pirkejiui ji sugadinus. Garantija taip pat netaikoma, prietaisą naudojant ne pagal paskirtį ir ir apgadinus

IT. GARANZIA

Sim darbarikam ir ligumā noteikta garantija visiem defektiem, kas saistās ar konstrukciju un materiālu, sākot ar pārdošanas datumu, kad mašīnu pārdod lietotājam un vienkārši uzrādot kases čeku. Garantija iekļauj bojāto daļu nomaiņu. Šī garantija nav derīga, ja aparāts nav lietots saskaņā ar drošības noteikumiem, ne gadījumos ja bojājumi radušies nesankcionētas iejaukšanās gadījumā vai arī pircēja nolaidības dēļ. Garantija nav derīga, ja bojājumi radušies darbarika defekta dēļ

HR. JAMSTVO

Ovaj alat ima ugovorno jamstvo u slučaju bilo kakvih nedostataka u konstrukciji i materijalu, od datuma prodaje korisniku uz jednostavno predocenje računa. Jamstvo se sastoji u zamjeni neispravnih dijelova. Ovo se jamstvo ne primjenjuje u slučaju uporabe i eksploatacije koja nije skladna standardima uređaja, niti u slučaju štete uzrokovane neovlaštenim intervencijama ili nemarnom kupca. Jamstvo se ne primjenjuje na štetu uzrokovanu nekim nedostatkom alata.

SERVICE APRÈS VENTE - AFTER SALE SERVICE

FARGROUP EUROPE - 192, Avenue Yves Farge - 37700 St. Pierre-des-Corps - FRANCE

fargroup@fargroup.net