

PEUGEOT



EnergyStand-189R



Peugeot Outillage

100517-3-G-20220406



FR **MANUEL D'UTILISATION** (*Notice originale*) :
NL **HANDBOEK** (*Vertaling van het oorspronkelijke*):
ES **MANUAL** (*Traducción del original*):
PT **MANUAL** (*Tradução do manual original*):
IT **MANUAL** (*Traduzione dell'avvertenza originale*):
EN **USING MANUAL** (*Original manual translation*):

Etabli portatif pliable
Opklapbare draagbare werkbank
Banco de trabajo portátil plegable
Bancada portátil dobrável
Banco da lavoro portatile pieghevole
Portable work stand

peugeot-outillage.com

100517



MERCI !



En choisissant ce produit **PEUGEOT**, vous permettez d'en diminuer l'impact environnemental !

En retravaillant l'emballage, nous avons supprimé **76 %** des produits dérivés des hydrocarbures.

Ces opérations ont ainsi permis **d'abaisser ses émissions de gaz à effet de serre, en utilisant moins de ressources naturelles.**

>>> Pour en savoir plus, flashez ce code
et retrouvez toutes les informations sur notre site :



1 DESCRIPTION DE L'APPAREIL

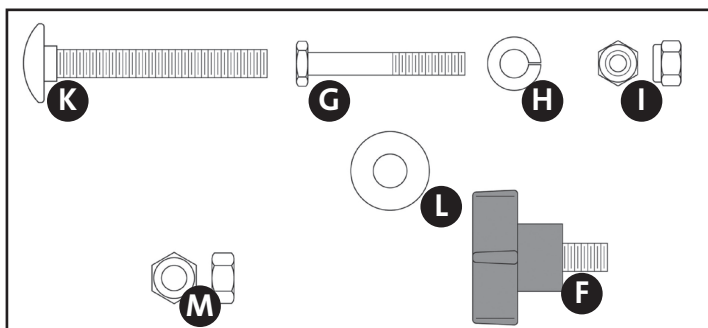
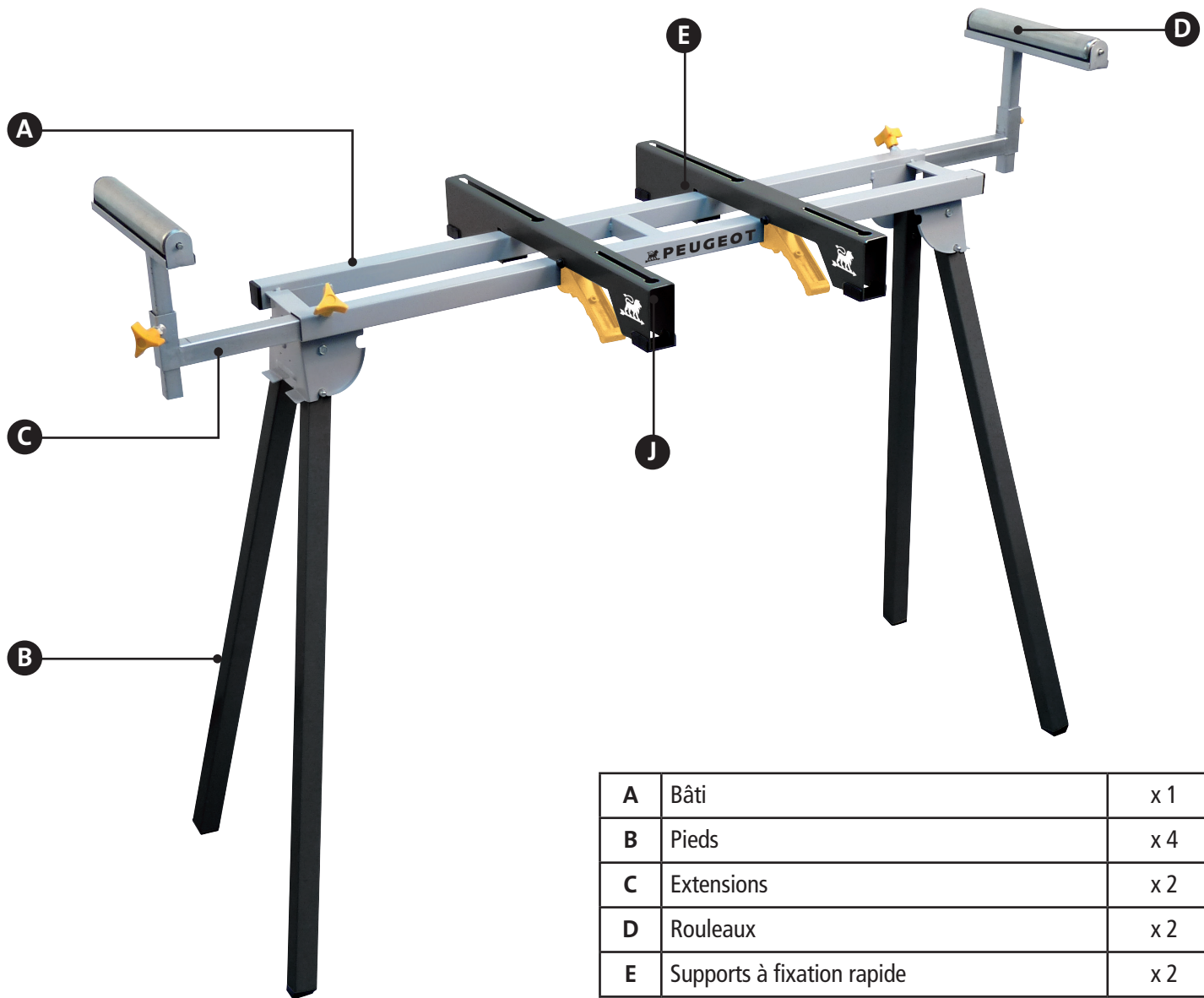

A	Bâti	x 1
B	Pieds	x 4
C	Extensions	x 2
D	Rouleaux	x 2
E	Supports à fixation rapide	x 2
F	Molette de serrage	x 4
G	Vis 6x55 mm	x 4
H	Rondelle 14 mm	x 4
I	Ecrou 14 mm	x 4
J	Pièce métallique	x 2
K	Vis pour fixer la machine	x 2
L	Rondelle	x 2
M	Ecrou	x 2

2 INSTRUCTIONS DE MONTAGE

Lire complètement toutes les instructions d'assemblage avant de commencer à assembler.

Certains composants peuvent être pré-assemblés usine.

ASSEMBLAGE

1- Déplier les pieds (2) et s'assurer qu'ils sont bien verrouillés en position comme il est illustré à la figure 1 et 2.

2. Faire glisser les extensions (C) dans le bâti (A) comme il est illustré à la figure 3. Verrouiller en position à l'aide des molettes de serrage (F)

3. Installer les servantes (D) comme il est illustré à la figure 4. Verrouiller en position à l'aide des molettes de serrage (F) comme il est illustré à la figure 5.

4. Placer les 2 supports à fixation rapide (E) comme il est illustré à la figure 6. Ajuster l'écartement en fonction des fixations de la machine. Pour les machines ayant des fixations non parallèles, passer à l'étape Fixations sur trous non alignés.

6. Utiliser les boulons écrous et rondelles pour fixer la machine sur son support comme il est illustré à la figure 7. Faire glisser la machine vers l'avant ou vers l'arrière le long du bloc de fixation afin de mieux équilibrer la machine sur le support. Serrer fermement les écrous. Attention, de la visserie spécifique peut être nécessaire suivant la machine à fixer. S'assurer de la stabilité de l'ensemble avant de commencer à travailler.

Fixations sur trous non alignés:

Dans le cas de fixation non-alignés, utiliser les pièces métalliques (J) comme il est illustré à la figure 8.

Procédure d'Installation et de repliage

1. Déposer la scie du support.
2. Escamoter les extensions pour réduire la taille du chevalet.
3. Appuyer sur le bouton pression de chaque patte pour les replier sous la partie supérieure du chevalet jusqu'à ce que le bouton pression s'enclenche en position fermée.

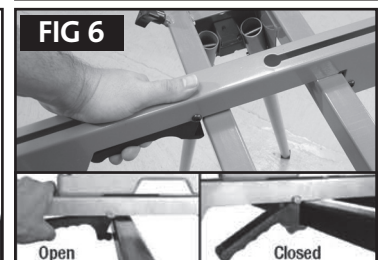
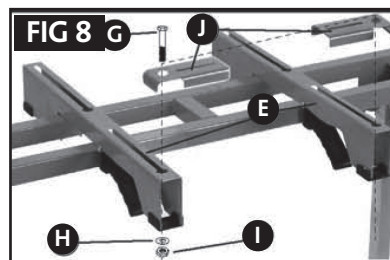
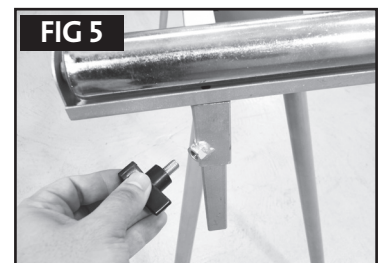
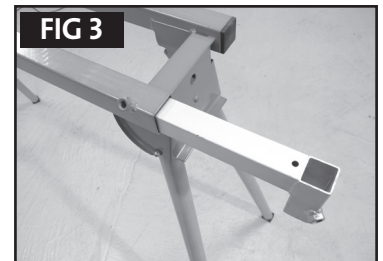
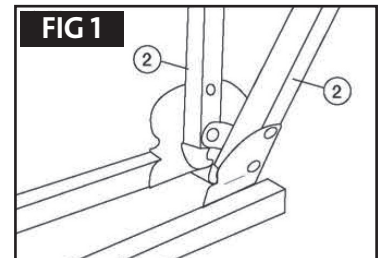
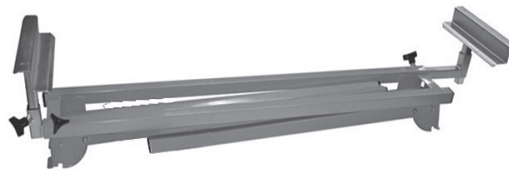

1 BESCHRIJVING VAN DE INRICHTING

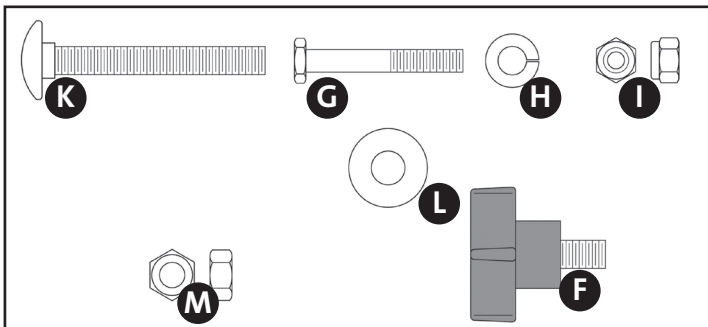
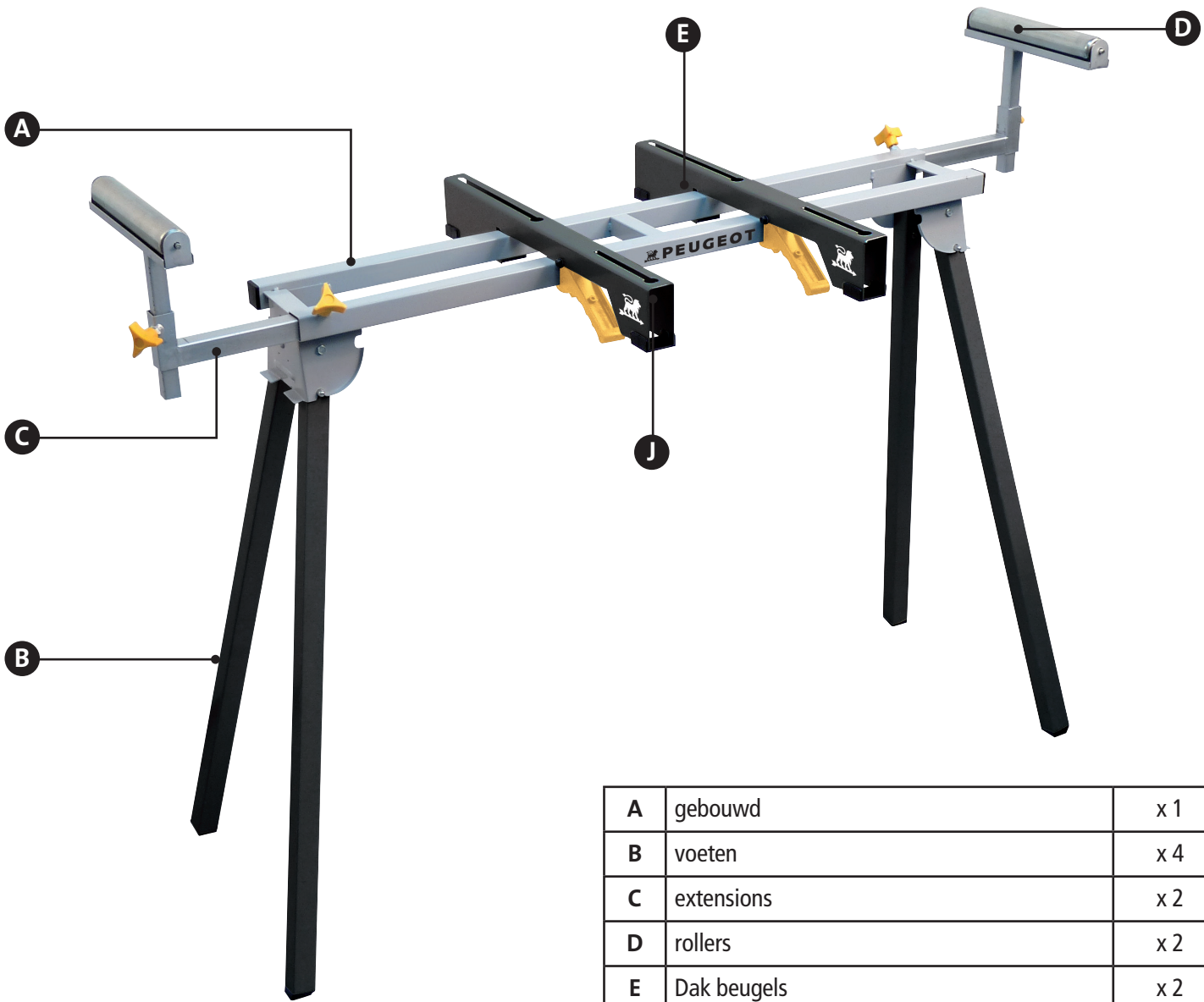

A	gebouwd	x 1
B	voeten	x 4
C	extensions	x 2
D	rollers	x 2
E	Dak beugels	x 2
F	Wielklemmen	x 4
G	schroef 6x55 mm	x 4
H	Washer 14 mm	x 4
I	Nut 14 mm	x 4
J	piece metal	x 2
K	Schroeven om de machine vast te zetten	x 2
L	Washer	x 2
M	Nut	x 2

2 MONTAGE-INSTRUCTIES

Lees alle montage instructies volledig voordat u begint te monteren.

Sommige componenten kunnen voormonteerde in de fabriek zijn.

MONTAGE

Ontvouwen 1 voet (2) en zorg ervoor dat ze worden vergrendeld zoals weergegeven in figuur 1 en 2.

2 Schuif uitbreidingen (C) in het frame (A) zoals getoond in figuur 3. Vergrendeling in positie met behulp van de klemmen wielen (F)

3 Installeer de bedienden (D) zoals weergegeven in figuur 4. Vergrendeling vast met de klemmende wielen (F) zoals getoond in figuur 5.

Plaats 4 Roofing beugels 2 (E) zoals getoond in figuur 6. Aanpassen van de afstand van de bevestigingsmiddelen overeenkomstig de machine. Voor machines met niet-parallelle banden, ga dan naar stap Fixaties op niet-gebonden gaten.

6 Gebruik bouten moeren en ringen om de houder vast te zetten op de machine zoals getoond in figuur 7. Schuif de machine naar voren of naar achteren langs de montage blok aan op de stand een betere balans van de machine. Draai de moeren. Aandacht voor de specifieke hardware vereist na de machone op te lossen. Zorgen voor de stabiliteit van de gehele vóór aanvang van de werkzaamheden.

Fixaties op niet-gebonden gaten:
Voor bevestiging nonaligned gebruik metalen delen (J) zoals getoond in figuur 8.

Installatieprocedure en vouwen

1 Verwijder de zaag uit de media.

2 Trek uitbreiding van de omvang van de brug verminderen.

Druk 3 om de drukknop voor elke tab in de gevouwen bovenste gedeelte van de brug tot de module vergrendeld in de gesloten positie.

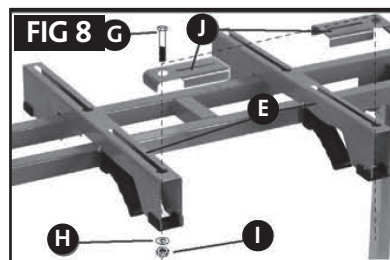
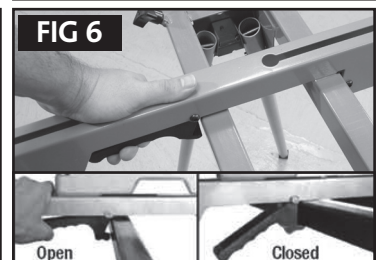
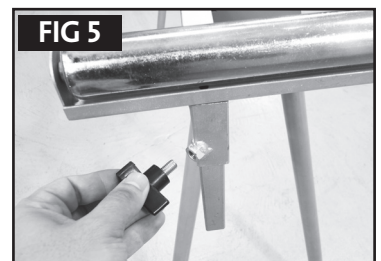
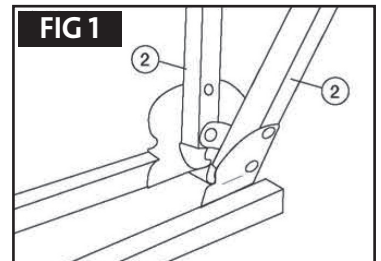

1 DESCRIPCIÓN DEL DISPOSITIVO

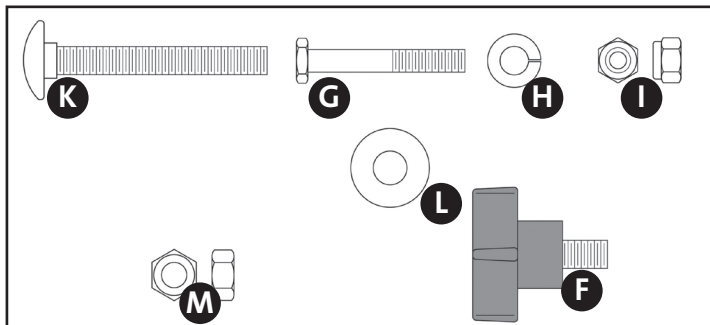
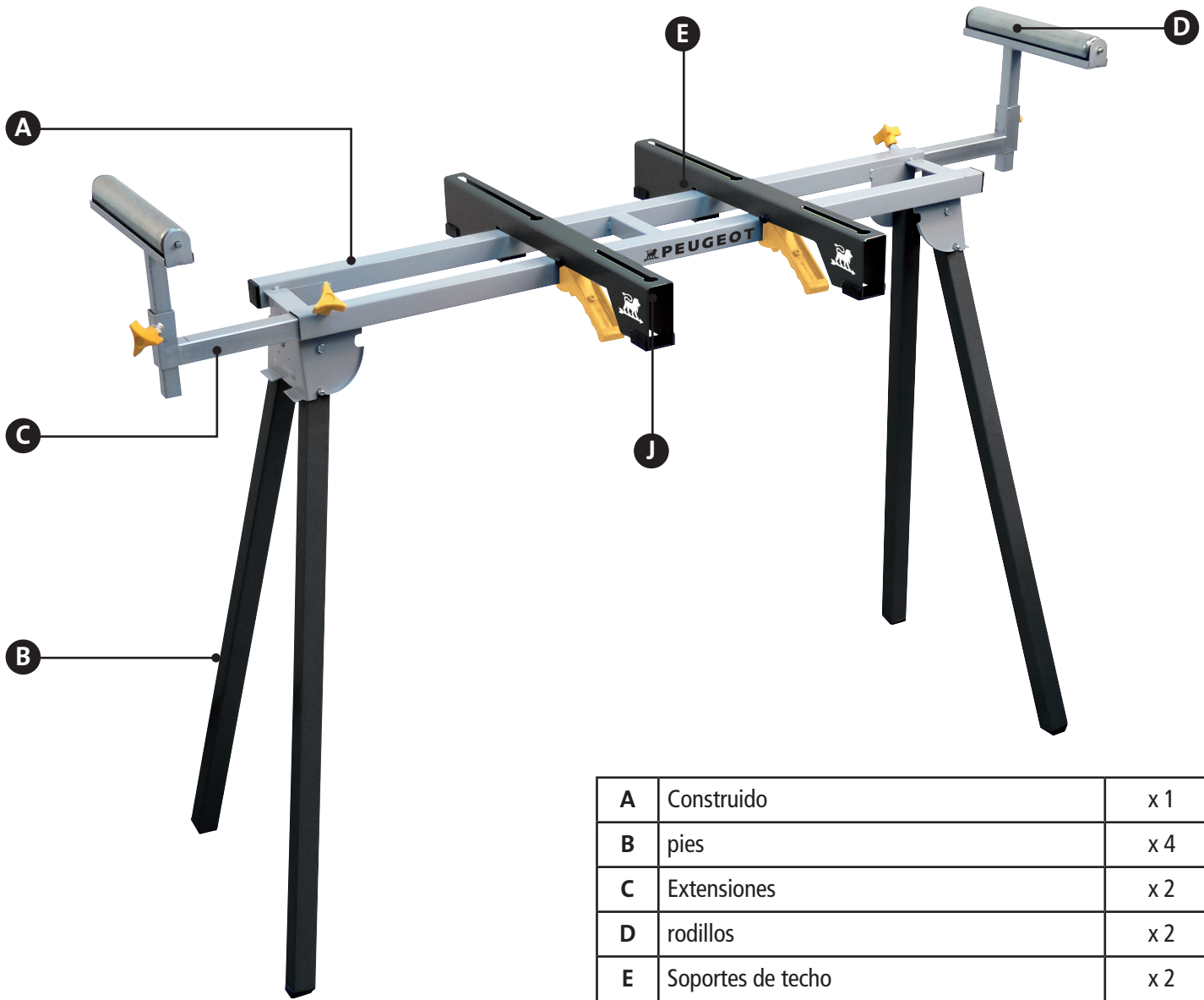

A	Construido	x 1
B	pies	x 4
C	Extensiones	x 2
D	rodillos	x 2
E	Soportes de techo	x 2
F	Sujeción de la rueda	x 4
G	Tornillo 6x55 mm	x 4
H	Lavadora 14 mm	x 4
I	Tuerca 14 mm	x 4
J	Pedazo de metal	x 2
K	Tornillos para asegurar la máquina	x 2
L	Lavadora	x 2
M	Tuerca	x 2

2 INSTRUCCIONES DE MONTAJE

Lea todas las instrucciones de montaje por completo antes de comenzar a ensamblar.

Algunos componentes pueden ser fábrica premontado.

ASAMBLEA

Desdoble 1 pie (2) y asegúrese de que estén fijos en la posición como se muestra en la figura 1 y 2.

Extensiones 2 Slide (C) en el bastidor (A) como se muestra en la Figura 3.
Bloqueo en posición utilizando las ruedas de sujeción (F)

3 Instale los funcionarios (D) como se muestra en la Figura 4.
Bloqueo en posición utilizando las ruedas de sujeción (F) como se muestra en la Figura 5.

Coloque 4 soportes de techo 2 (E) como se muestra en la Figura 6.
Ajuste de la separación de los elementos de fijación de acuerdo con la máquina.
Para las máquinas con las consolidaciones no paralelos, vaya al paso Fijaciones en agujeros no alineados.

6 Use pernos tuercas y arandelas para fijar el soporte en la máquina, como se muestra en la Figura 7.
Deslice la máquina hacia delante o hacia atrás a lo largo del bloque de montaje para equilibrar mejor la máquina en el stand. Apretar las tuercas.
Atención al hardware específico puede ser necesaria después de la machone de arreglar.
Asegurar la estabilidad del conjunto antes de comenzar el trabajo.

Fijaciones en agujeros no alineados:
Para la fijación de las piezas metálicas uso no alineados (J) como se muestra en la Figura 8.

Procedimiento de instalación y plegado

1 Retire la sierra de los medios de comunicación.

2 Retraer extensiones para reducir el tamaño del puente.

Pulse 3 para el botón de presión para cada pestaña en la parte superior plegada del puente hasta el complemento enclava en la posición cerrada.

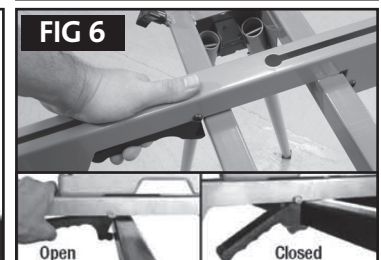
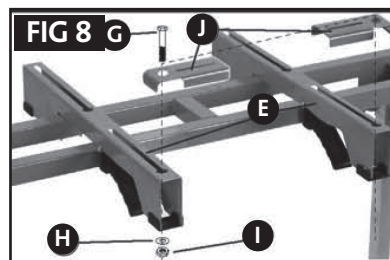
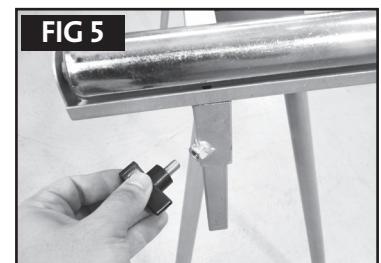
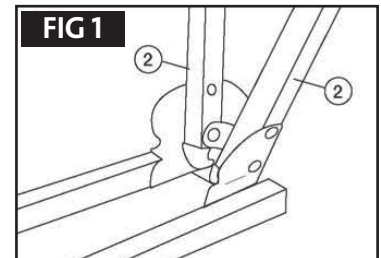
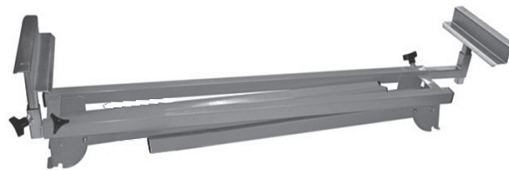

1 DESCRIÇÃO DO DISPOSITIVO

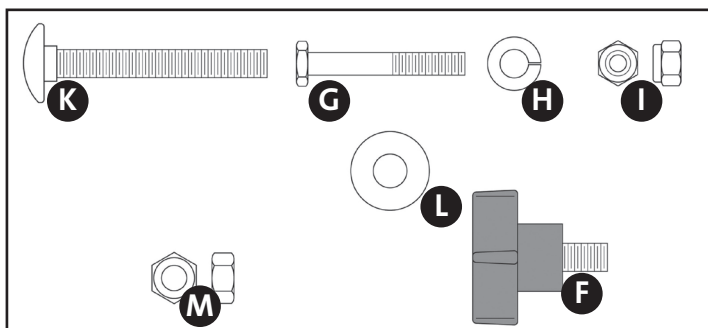
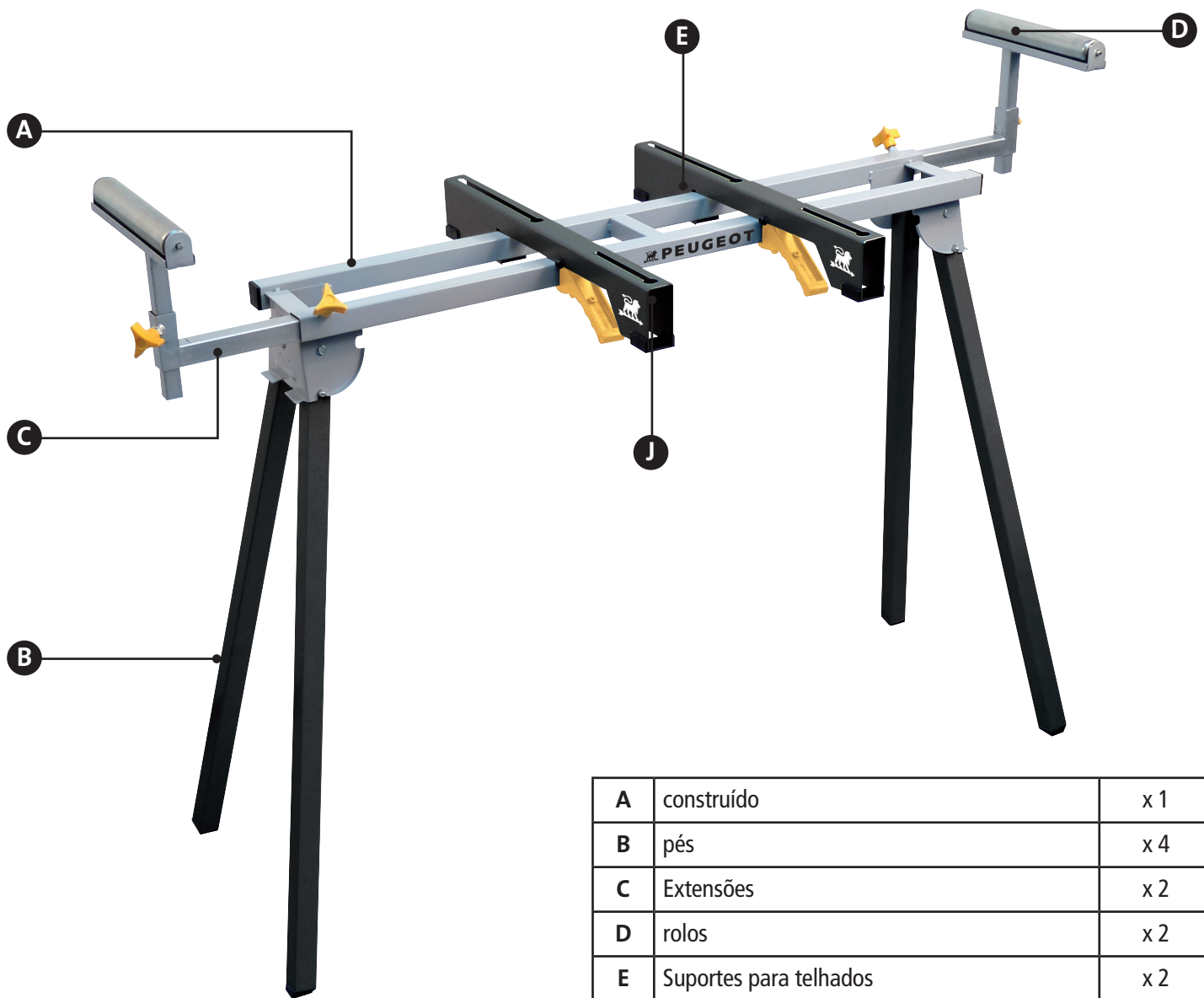

A	construído	x 1
B	pés	x 4
C	Extensões	x 2
D	rolos	x 2
E	Suportes para telhados	x 2
F	Aperto das rodas	x 4
G	Parafuso 6x55 mm	x 4
H	Máquina de lavar roupa 14 mm	x 4
I	Nut 14 mm	x 4
J	pedaço de metal	x 2
K	Parafusos para fixar a máquina	x 2
L	Máquina de lavar roupa	x 2
M	Nut	x 2

2 INSTRUÇÕES DE MONTAGEM

Leia todas as instruções de montagem completamente antes de se iniciar a montagem.

Alguns componentes podem ser pré-montado de fábrica.
ASSEMBLEIA

Desdobrar um pé (2) e verifique se eles estão travados na posição como mostrado na Figura 1 e 2.

2 extensões deslizantes (C) no quadro (A) como mostrado na Figura 3.
Bloqueio em posição utilizando as rodas de fixação (F)

3 Instale os servos (D), conforme mostrado na Figura 4.
Bloqueio em posição utilizando as rodas de fixação (F), como mostrado na Figura 5.

Coloque 4 suportes para telhados 2 (E), como mostrado na Figura 6.
Ajustar o espaçamento dos elementos de fixação de acordo com a máquina.
Para máquinas com ligações não-paralelas, vá para o passo
Fixações no furos não-alinhados.

6 Use parafusos porcas e arruelas para fixar o suporte na máquina, como mostrado na Figura 7.
Deslize a máquina para frente ou para trás ao longo do bloco de montagem para melhor equilibrar a máquina no suporte. Aperte as porcas.
Atenção para o hardware específico pode ser necessária após a MachOne de corrigir.
Assegurar a estabilidade do todo antes de começar a trabalhar.

Fixações no furos não-alinhados:
Para fixação de peças a utilização de metais não alinhados (J) como mostrado na Figura 8.

Procedimento de Instalação e dobrar

1 Remova a serra da mídia.

2 retrain as extensões para reduzir o tamanho da ponte.

Pressione o botão 3 para a pressão de cada aba na parte superior dobrada da ponte até ao encaixe tranca na posição fechada.

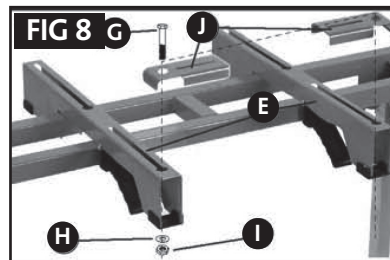
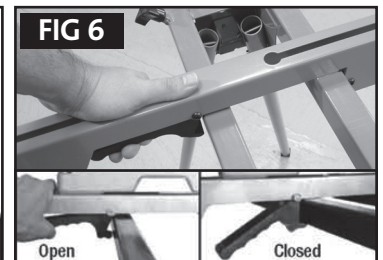
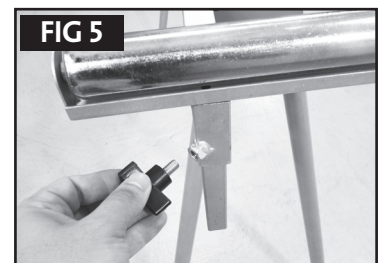
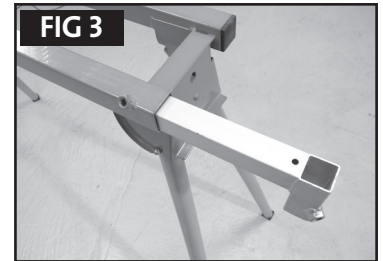
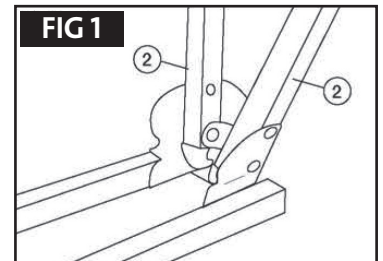

1 DESCRIZIONE DEL DISPOSITIVO

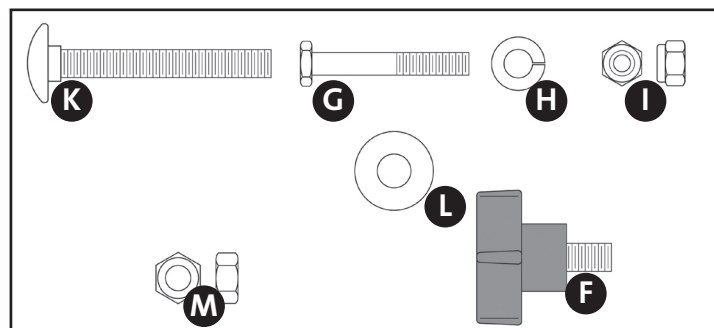
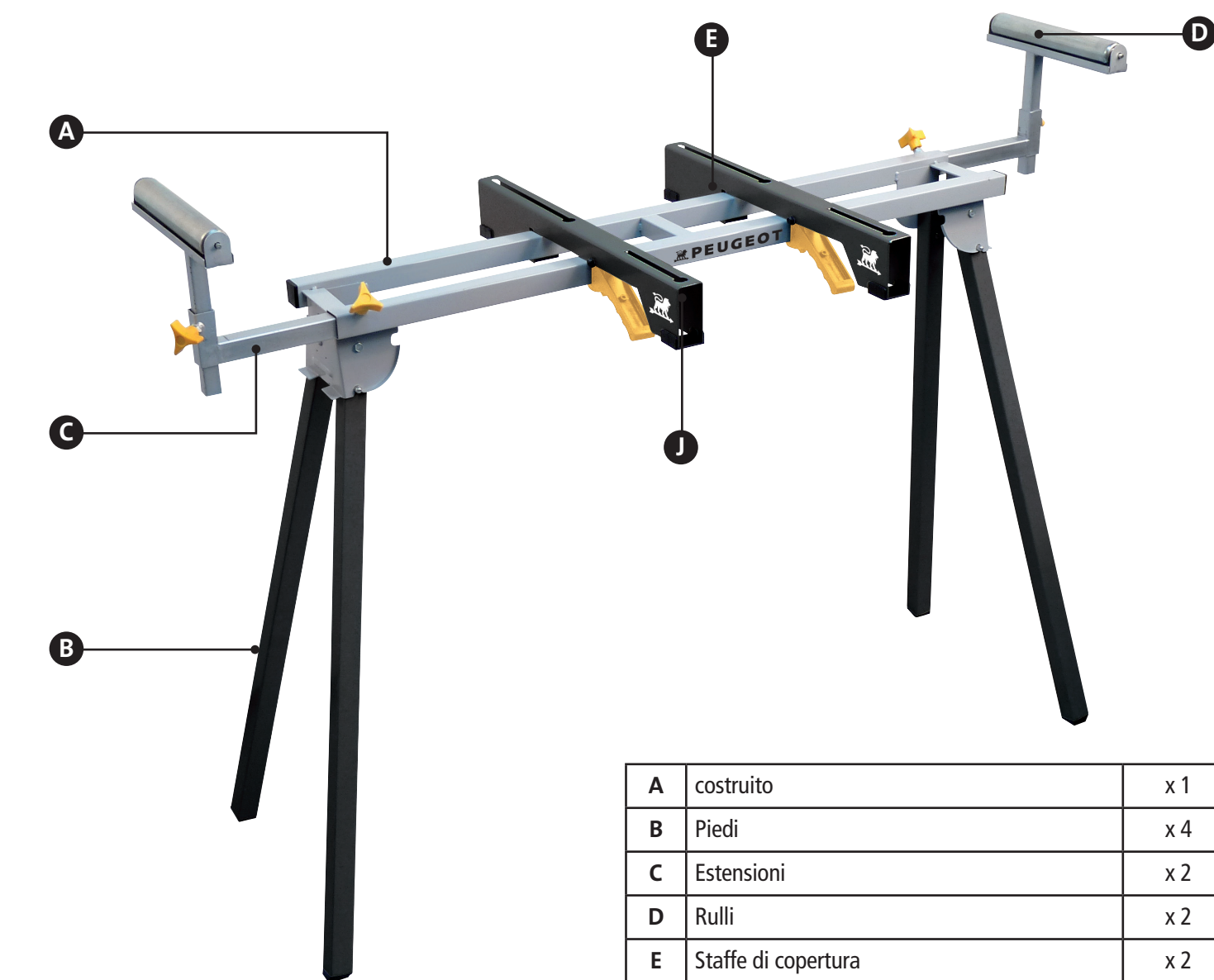

A	costruito	x 1
B	Piedi	x 4
C	Estensioni	x 2
D	Rulli	x 2
E	Staffe di copertura	x 2
F	Bloccaggio della ruota	x 4
G	vite 6x55 mm	x 4
H	rondella 14 mm	x 4
I	dado 14 mm	x 4
J	pezzo di metallo	x 2
K	Viti per fissare la macchina	x 2
L	rondella	x 2
M	dado	x 2

2 ISTRUZIONI DI MONTAGGIO

Leggere completamente tutte le istruzioni per il montaggio prima di iniziare a montare.

Alcuni componenti possono essere preassemblato in fabbrica.

MONTAGGIO

Unfold 1 piede (2) e accertarsi che siano bloccati in posizione, come illustrato nella figura 1 e 2.

2 Far scorrere le estensioni (C) nel telaio (A) come mostrato in figura 3. Blocco in posizione utilizzando le ruote di bloccaggio (F)

3 Installare i servi (D) come mostrato in Figura 4. Blocco in posizione utilizzando le ruote di serraggio (F) come mostrato in Figura 5.

Mettere 4 staffe di copertura 2 (E), come mostrato in Figura 6. Regolare la spaziatura degli elementi di fissaggio secondo la macchina. Per le macchine con attacchi non parallele, andare al passaggio Fissazioni su fori non allineati.

6 Utilizzare i bulloni dadi e rondelle per fissare il supporto sulla macchina, come mostrato in Figura 7. Far scorrere la macchina in avanti o indietro lungo il blocco di montaggio per meglio bilanciare la macchina sul cavalletto. Serrare i dadi. Attenzione al hardware specifico può essere richiesto in seguito alla macchina da risolvere. Garantire la stabilità dell'intera prima di iniziare il lavoro.

Fissazioni su fori non allineati:

Per fissare le parti metalliche utilizzo non allineati (J) come mostrato in figura 8.

Procedura di installazione e pieghevole

1 Rimuovere la sega da parte dei media.

2 Ritrarre estensioni per ridurre le dimensioni del ponte.

Premere 3 per il pulsante di pressione per ogni scheda nella parte superiore ripiegata del ponte fino ad agganciare i fermi nella posizione di chiusura.

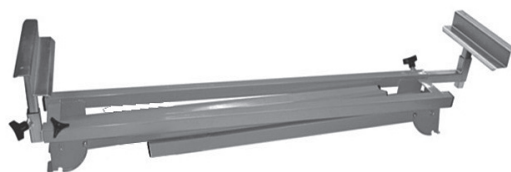
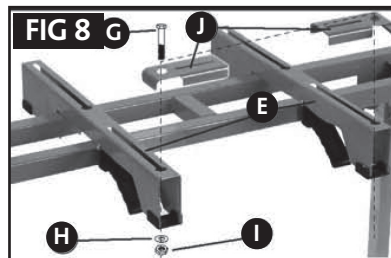
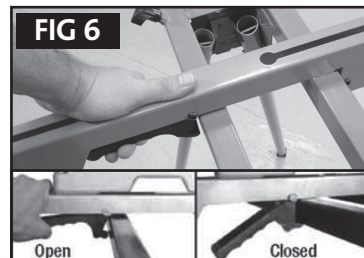
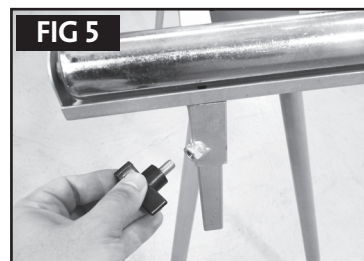
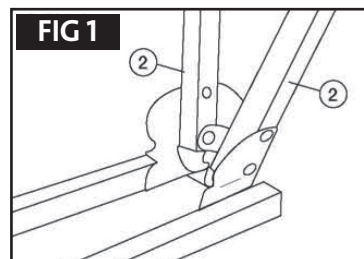

1 DESCRIPTION OF THE DEVICE

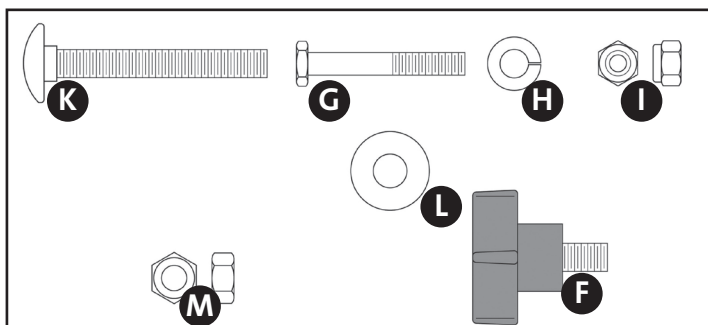
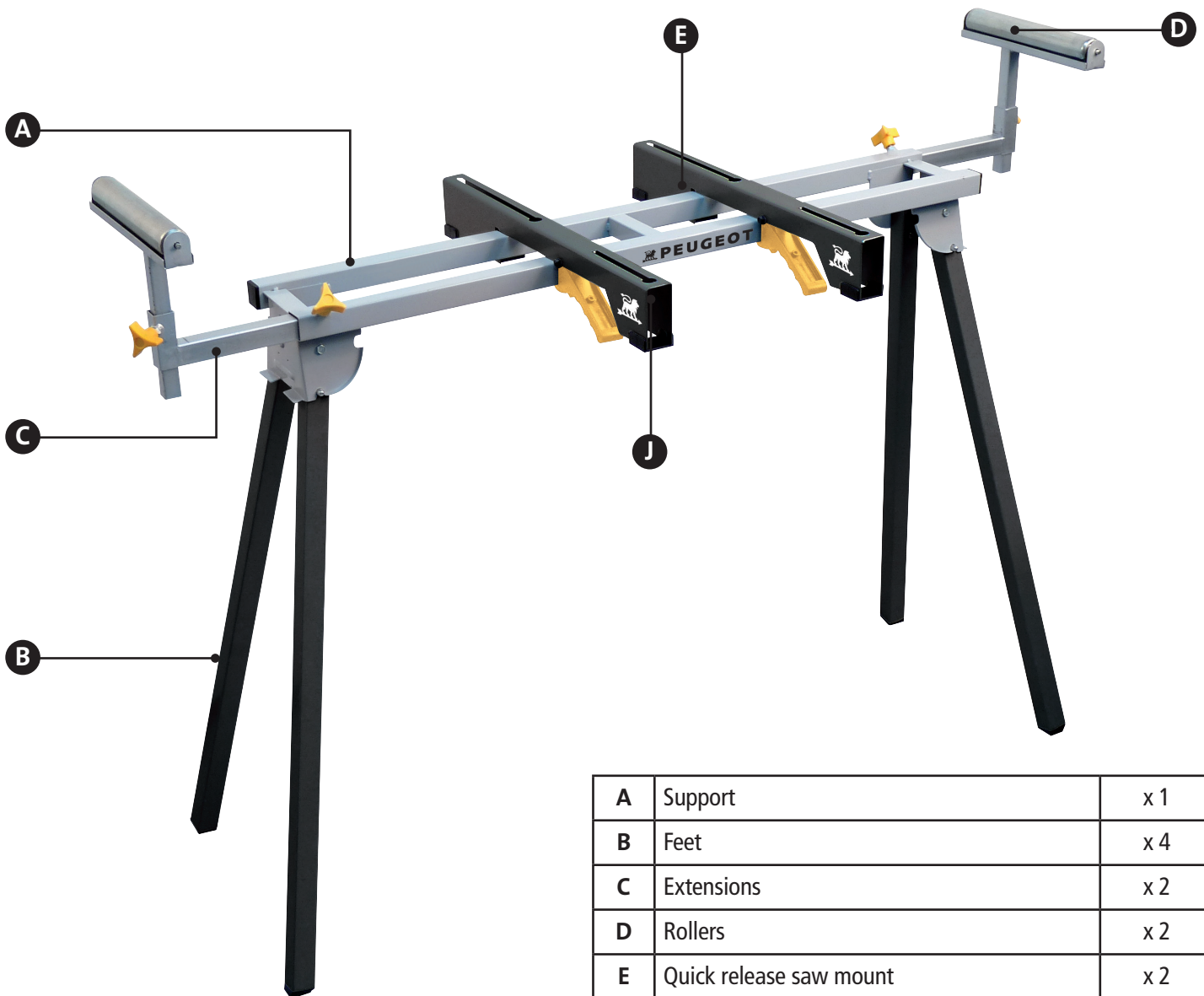

A	Support	x 1
B	Feet	x 4
C	Extensions	x 2
D	Rollers	x 2
E	Quick release saw mount	x 2
F	Lock knob	x 4
G	Bolt 6x55 mm	x 4
H	Washer 14 mm	x 4
I	Nut 14 mm	x 4
J	Offset bracket	x 2
K	Bolts	x 2
L	Washer	x 2
M	Nut	x 2

2 MOUNTING INSTRUCTIONS

Read all assembly instructions completely before beginning to assemble.

Some components may be preassembled factory.
ASSEMBLY

Unfold 1 foot (2) and make sure they are locked in position as shown in Figure 1 and 2.

2 Slide extensions (C) in the frame (A) as shown in Figure 3.
Locking in position using the clamping wheels (F)

3 Install the servants (D) as shown in Figure 4.
Locking in position using the clamping wheels (F) as shown in Figure 5.

Place 4 Roofing brackets 2 (E) as shown in Figure 6.
Adjusting the spacing of the fasteners according to the machine.
For machines with non-parallel bindings, go to step
Fixations on non-aligned holes.

6 Use bolts nuts and washers to fix the holder on the machine as shown in
Figure 7.
Slide the machine forward or backward along the mounting block to better balance the machine on the stand. Tighten the nuts.
Attention to the specific hardware may be required following the machine to fix.
Ensure the stability of the whole before starting work.

Fixations on non-aligned holes:
For fixing nonaligned use metal parts (J) as shown in Figure 8.

Installation Procedure and folding

1 Remove the saw from the media.

2 Retract extensions to reduce the size of the bridge.

Press 3 to the pressure button for each tab in the folded upper portion of the bridge until the snap latches in the closed position.

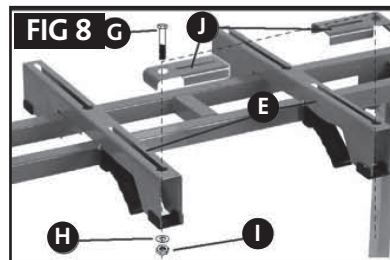
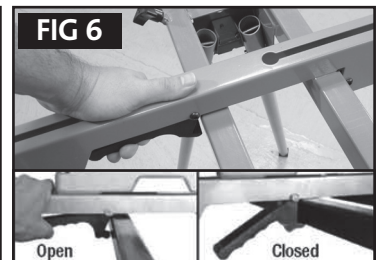
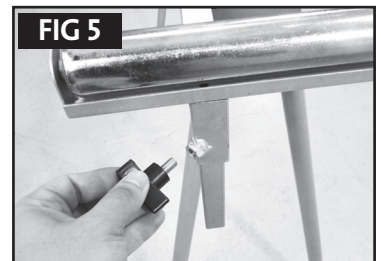
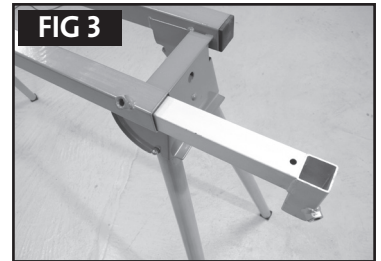
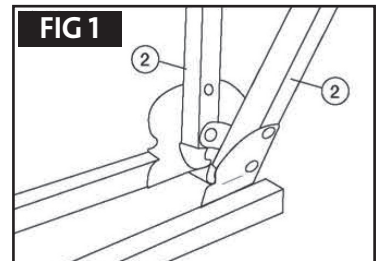



FR - INSTRUCTIONS DE SÉCURITÉ POUR SUPPORTS DE SCIE À ONGLETS

1. Plier et déplier les pieds avec précaution afin de limiter les points de pincement des doigts.
2. Placer le support sur une surface plane et de niveau pour que l'outil ne puisse pas se balancer ou basculer.
3. S'assurer que les extensions de support de la pièce sont dans des limites d'utilisation sécuritaires et qu'elles sont verrouillées en place avant d'utiliser l'outil. Ne pas placer un poids supérieur à 100 kg (300 lb) sur la table du cadre principal.
4. Vérifier la stabilité de l'installation avant de commencer à l'utiliser.
5. S'assurer que la scie à onglets est serrée de façon sécuritaire au niveau de tous les montages avant d'utiliser ou de plier le support pour le transporter.

NL - AANWIJZINGEN VOOR EFFECTENHOUDERS VERSTEKZAAG

1. Vouw en vouw de poten zorgvuldig te knijpen punten vingers minimaliseren.
2. Plaats de voet op een vlak en niveau, zodat de machine niet kan zwaaien of kantelen.
3. Zorg ervoor dat de support-uitbreidingen van het stuk in veilige operationele grenzen en vergrendeld zijn voordat u het gereedschap. Heeft een hoger gewicht niet plaatsen 100 kg (300 lb) op de tafel van het main frame.
4. Controleer de stabiliteit van het systeem voordat u deze gaat gebruiken.
5. Zorg ervoor dat de verstekzaag en vastgedraaid helemaal mounts voor het gebruiken of opvouwbare beugel voor transport.

ES - INSTRUCCIONES DE SEGURIDAD PARA LOS SOPORTES DE SIERRA DE MITRAR

1. Use cautela al doblar y desdoblar las patas a fin de evitar cualquier punto de pellizco de dedos.
2. Coloque el soporte en una superficie plana y nivelada de modo que la herramienta no se balancee ni se vuelque.
3. Cerciórese de que las extensiones de soporte de trabajo estén dentro de los límites de operación segura y que estén correctamente trabadas en su lugar antes de usar la herramienta. No se debe exceder las 300 libras sobre la mesa del armazón principal.
4. Compruebe la instalación por estabilidad antes de proceder con la tarea.
5. Asegúrese de que la sierra de mitrar esté bien fijada en todos los montajes antes de usar o doblar el soporte para su transporte.

PT - INSTRUÇÕES DE DETENTORES DE TÍTULOS DE SERRA DE ESQUADRIA

1. Dobre e desdobre as pernas cuidadosamente para minimizar pontos de aperto dedos.
2. Coloque a base sobre uma superfície plana e nivel para que a ferramenta não pode influenciar ou inclinação.
3. Verifique se as extensões de apoio da peça estão em limites seguros de operação e são travados antes de usar a ferramenta. Não coloque um peso maior 100 kg (300 lb) sobre a mesa do quadro principal.
4. Verifique a estabilidade do sistema antes de começar a usá-lo.
5. Verifique se a serra de esquadria e bem apertados em todas as montagens antes de usar ou dobrável suporte para o transporte.

IT - ISTRUZIONI TITOLARI SICUREZZA MITRA SEGA

1. Piegare e dispiegare le gambe per ridurre al minimo i punti di pressione delle dita.
2. Posizionare il supporto su una superficie piana e livello in modo che lo strumento non è in grado di influenzare o inclinazione.
3. Assicurarsi che le estensioni di supporto del pezzo sono limiti operativi sicuri e sono bloccati in posizione prima di usare lo strumento. Non collocare un peso più elevato 100 kg (300 lb) sul tavolo del telaio principale.
4. Verificare la stabilità del sistema prima di iniziare ad usarlo.
5. Assicurarsi che la troncatrice e serrato saldamente a tutti i supporti prima di utilizzare o staffa pieghevole per il trasporto.

EN - SAFETY INSTRUCTIONS FOR MITER SAW STANDS

1. Use caution when folding or unfolding legs to limit any finger pinch points.
2. Place stand on flat and level surface to keep tool from rocking or tipping.
3. Make certain that work support extensions are within safe operating limits, and are properly locked in place before using tool. Do not exceed 300 lbs. on main frame table.
4. Test the setup for stability before proceeding with work.
5. Be sure the miter saw is tightened securely at all mountings before use.

	<p>LIRE LES INSTRUCTIONS AVANT USAGE :</p> <p>LEES VOOR HET GEBRUIK DE INSTRUCTIES:</p> <p>LÉASE LAS INSTRUCCIONES ANTES DE USAR:</p> <p>LER AS INSTRUÇÕES ANTES DA UTILIZAÇÃO:</p> <p>LEGGERE LE ISTRUZIONI PRIMA DELL'USO:</p> <p>READ THE INSTRUCTIONS BEFORE USE:</p>	X
--	---	---

	<p>POIDS :</p> <p>GEWICHT:</p> <p>PESO:</p> <p>PESO:</p> <p>WEIGHT:</p>	11,5 kg
--	---	---------

	<p>RECYCLABLE, SOUMIS AU TRI SÉLECTIF:</p> <p>Recyclable, subject to recycling:</p> <p>RECYCLEBAAR, ONDER VOORBEHOUD VAN HET SORTEREN:</p> <p>RECICLABLE, SIN PERJUICIO DE LA CLASIFICACIÓN:</p> <p>RECICLÁVEL, SUJEITO A TRIAGEM:</p> <p>RICICLABILE, SOGGETTO A CERNITA:</p>	X
--	--	---





Plaques signalétiques - Naamplaatjes - Placas de identificación - Placas de identificação - Targhette - Machine labels

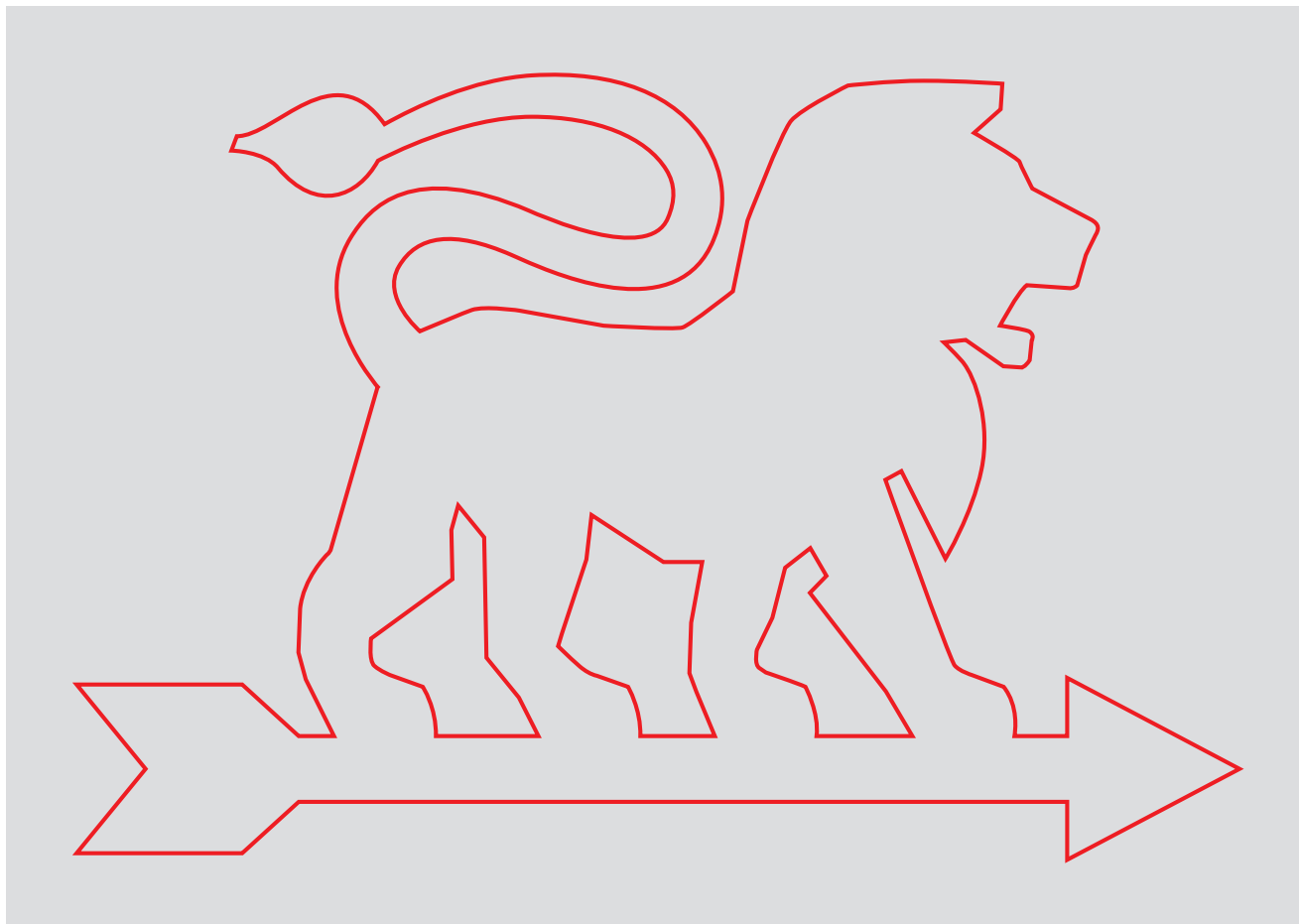

PEUGEOT EnergyStand 189R

DATE UWC202 Peugeot Outillage
 SERIE 192, Avenue Yves Farge
 37700 St. Pierre-des-Corps - FRANCE

1000 mm 2500 mm 750 mm 250 mm 100 Kg 11,5 Kg

100517

Made in F.R.C.

100517-3-Sticker-E-01-Normes.indd 1 28/03/2022 12:06



PEUGEOT



5 ANS**PEUGEOT****GARANTIE PEUGEOT****BON DE GARANTIE****1 - Objet de la garantie :**

La garantie porte exclusivement sur les vices de fabrication ou les vices de matières.

Elle nous oblige à l'échange ou à la réparation des pièces reconnues hors d'usage.

2 - Durée de la garantie :

La garantie est de 60 mois à dater de la livraison du matériel à l'utilisateur (facture ou ticket de caisse à fournir).

Les échanges ou réparations faites au titre de la garantie ne peuvent avoir pour effet de prolonger celle-ci.

Les frais de port ALLER sont à la charge de l'utilisateur.

3 - Réserves :

La garantie ne s'applique en aucun cas aux réparations effectuées en dehors de nos réparateurs agréés.

En aucun cas, durant la période de garantie, le matériel ne devra être démonté.

GARANTIEKAART**1 - Doel van de garantie:**

De garantie heeft uitsluitend betrekking op fabricagefouten of gebreken in materialen.

Het dwingt ons om uit te wisselen of reparatie van erkende onbruikbare onderdelen.

2 - Duur van de garantie:

De garantie bedraagt 60 maanden vanaf de levering van apparatuur voor de gebruiker (factuur of kassabon te verstrekken).

De uitwisseling of reparaties onder garantie niet te verlengen.

GO verzendkosten zijn voor rekening van de gebruiker.

3 - Reserves:

De garantie geldt niet in alle reparaties die buiten onze goedgekeurde reparateurs.

In ieder geval gedurende de garantie, moet het materiaal worden verwijderd.

TARJETA DE GARANTÍA**1 - Objeto de la garantía:**

La garantía sólo se referirá a los defectos de fabricación o defectos en los materiales.

Nos obliga a cambiar o reparación de las piezas fuera de servicio reconocido.

2 - Duración de la garantía:

La garantía es de 60 meses a partir de la entrega de equipos para el usuario (factura o recibo que se den).

Los intercambios o reparaciones bajo garantía no tendrá que prolongarse.

GO gastos de envío correrán a cargo del usuario.

3 - Reservas:

La garantía no se aplica en todas las reparaciones realizadas fuera de nuestros talleres de reparación autorizados.

En cualquier caso, durante el período de garantía, el material debe ser removido.

CARTÃO DE GARANTIA**1 - Finalidade da garantia:**

A garantia só relacionar com defeitos de fabricação ou defeitos em materiais.

Ela nos obriga a troca ou reparo de peças inseríveis reconhecidos.

2 - Duração da Garantia:

A garantia é de 60 meses a partir da entrega de equipamentos para o usuário (fatura ou recibo a ser fornecido).

Trocas ou reparos sob a garantia não terá que prorrogá-la.

GO porte serão custeadas pelo usuário.

3 - Reservas:

A garantia não se aplica a quaisquer reparos feitos fora das nossas oficinas aprovadas.

Em qualquer caso, durante o período de garantia, o material deve ser removido.

GARANZIA**1 - Oggetto della garanzia:**

La garanzia si riferisce esclusivamente alla difetti di fabbricazione o difetti nei materiali.

Ci costringe a scambio o la riparazione di parti inutilizzabili riconosciuti.

2 - Durata della garanzia:

La garanzia è di 60 mesi dalla consegna delle attrezzature per l'utente (fattura o ricevuta da fornire).

Scambi o riparazioni in garanzia non sarà necessario prolungarla.

GO spese di spedizione sono a carico dell'utente.

3 - Riserve:

La garanzia non si applica in tutte le riparazioni effettuate al di fuori dei nostri riparatori autorizzati.

In ogni caso, durante il periodo di garanzia, il materiale deve essere rimosso.

WARRANTY**1 - Scope of the warranty :**

The warranty shall only apply to manufacturing defects or material defects.

We are obliged to exchange or repair parts that are identified as being unusable

2 - Lifetime warranty :

The warranty shall be valid for 60 months from the delivery date of the equipment to the user (invoice or till receipt must be provided).

Exchanges or repairs carried out under the warranty shall not extend the original warranty period.

The user shall be responsible for original shipping charges.

3 - Reservations :

The warranty shall not under any circumstances cover repairs carried out by a non-authorized repairer.

The equipment should not be dismantled under any circumstances during the warranty period.

DATE D'ACHAT	RÉFÉRENCE MACHINE	CACHET DU DISTRIBUTEUR
DATUM VAN AANKOOP	MACHINEREFERENTIE	DEALER STEMPEL
FECHA DE COMPRA	REFERENCIA DE LA MÁQUINA	COMERCIANTE DE SELLOS
DATA DA COMPRA	REFERÊNCIA DE MÁQUINA	SELO REVENDEDOR
DATA DI ACQUISTO	RIFERIMENTO MACCHINA	TÍMBRO DEL RIVENDITORE
PURCHASE DATE	MACHINE CODE	DISTRIBUTOR'S STAMP

SERVICE APRÈS VENTE - AFTER SALE SERVICE

PEUGEOT OUTILLAGE - 192, Avenue Yves Farge - 37700 St. Pierre-des-Corps - FRANCE - Tél. : 02 36 16 71 46 - Fax : 02 36 16 71 40



PEUGEOT OUTILLAGE

Une société du groupe **SIGMA**

192, Avenue Yves Farge
37700 St. Pierre-des-Corps
FRANCE

www.peugeot-outillage.com

