



Standard spring-diaphragm pressure gauges MF100Dif

Part no. 88090401

Standard spring-diaphragm pressure gauges for differential pressure - overload protected

benefits

- direct indication of the differential pressure
- high overload protection
- Zero correction
- with integrated pressure damping

Application

For differential pressure measurement at low differential pressure and high static pressure. For non-corrosive gaseous and liquid media which are not highly viscous. Particularly suitable for monitoring filters, pumps and pipe systems.

Technical Specifications

Type

MF100Dif D401

Nominal size

100

Function

The pressures act on two pressure chambers separated by an elastic diaphragm. If there are different pressures in the chambers, the diaphragm is axially displaced against a compression spring. This is transmitted to the movement by means of a rod. The differential pressure is directly indicated by a pointer. The diaphragm is held by a metallic support which results in an overpressure safety of up to 25 bar at both sides.

accuracy class (EN 837-3/6)

2.5

ranges

see ordering table

maximum static pressure

25 bar

Overpressure safety

up to the maximum static pressure at both ends

Operating temperature range

Medium: max. 60 °C

Ambient: -20/+60 °C

Temperature performance

Indication error when the temperature of the measuring system deviates from the normal temperature of 20 °C:
 at rising temperature approx. ± 0.5 %/10 K
 falling temperature approx. ± 0.5 %/10 K
 of full scale value

Degree of protection

IP 54 (EN 60529)

Connection

Brass nickel-plated
 bottom, parallel, one behind the other

Measuring element

Compression spring, Stainless steel 301

diaphragm
FKM (Viton)

Measuring flange
Aluminium, anodized

movement
Brass

Dial
Aluminium, white
Scaling: black

Pointer
Aluminium, black

Housing
Stainless steel 304

bayonet bezel
Stainless steel 304

window
Laminated safety glass

Options

- Glycerine filling (type D 8)
- back flange
- special scales
- other process connections

Technical Drawings

Bottom connection

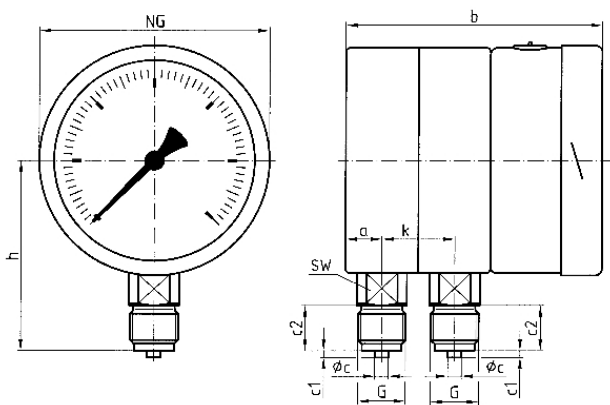

Dimensions (mm)

NG	a	b	∅c	c1	c2	G	h	k	SW
100	16	112,5	6	3	20	G½B	84	32	22

Versions

Type	housing ø	Housing	accuracy class	Con- nection	Ausrich- tung	Range	Type	Type	Part no.
MF100Dif D401	100 mm	Stain- less steel 304	2.5	2 x G½B		0/1.6 bar	MF100Dif	D401	● 88090401

● in-stock items

● Non-stock items