

sludge separator G1½

Part no. 40683

sludge separator



benefits

- pre-assembled and tightness-tested assembly
- Single-operation cleaning while the system is running
- Energy savings due to improved heat transfer at system components
- easy, fast integration into existing pipes via reducer unions

Application

For removing dirt particles from heating systems. Particles can cause problems in fittings and control units. The sludge separator ensures clean water, reliable operation, better and faster heat transfer and thus contributes to reduced fuel consumption and emissions. Suitable for hot water heating systems and underfloor heating systems. Rust, lime particles, calcium, magnesium, oxides, carbonates and sludge as well as larger particles such as chips or construction residues are removed from the water – without the use of chemicals. Excellent for the renovation of system parts subject to sludge accumulation.

Description

Compact sludge separator with drain valve in form-fit insulation. The highly efficient concept removes sludge from the water. Plates in the separator deflect the particles into a separate area. From there, the dirt particles can be flushed out during normal operation by means of a valve. The sludge separator can be combined with the air separator and can be installed in the flow (preferred) or return lines. Reducer unions G1 female and G¾ female are available for renovation or retrofitting in existing pipes.

Technical Specifications

Housing

Brass

Insulation

Polypropylene EPP

Operating pressure

max. 10 bar

Flow coefficient Kvs

13.6 m³/h (flow top down)

14.7 m³/h (flow bottom up)

Operating temperature range

Medium: max. 95 °C

Connections

top: G1½ female (union nut)

bottom: G1½ male

Mounting position
vertical

Technical Drawings

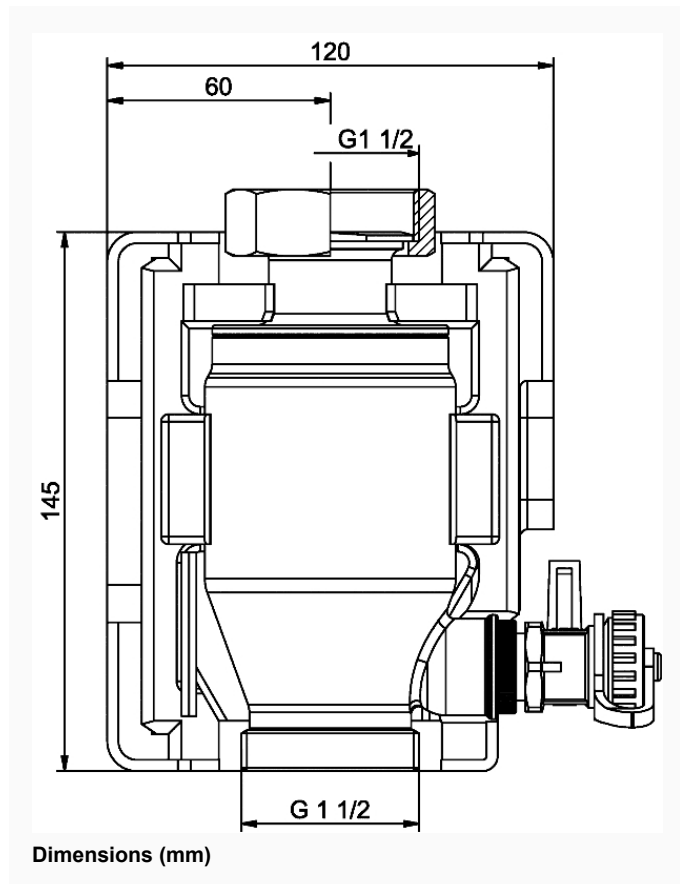

Versions

Part no.

sludge separator
G1½



40683

- in-stock items
- Non-stock items