

# TIMKEN

The Timken Company  
 4500 Mt Pleasant St. NW  
 N. Canton, OH 44720  
 Phone: (234) 262-3000  
 E-Mail: CustomerCAD@timken.com • Web site: www.timken.com

## Timken Part Number LM48548 - LM48510, Tapered Roller Bearings - TS (Tapered Single) Imperial

This is the most basic and most widely used type of tapered roller bearing. It consists of two main separable parts: the cone (inner ring) assembly and the cup (outer ring). It is typically mounted in opposing pairs on a shaft.

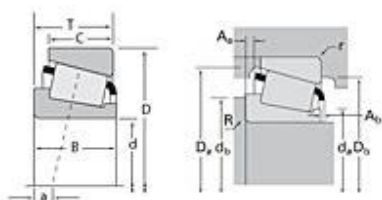

[Specifications](#) | [Dimensions](#) | [Abutment and Fillet Dimensions](#) | [Basic Load Ratings](#) | [Factors](#)

### Specifications

<b>Series</b>	LM48500
<b>Cone Part Number</b>	LM48548
<b>Cup Part Number</b>	LM48510
<b>Design Units</b>	Imperial
<b>Bearing Weight</b>	0.50 lb 0.200 Kg
<b>Cage Type</b>	Stamped Steel

### Dimensions

<b>d - Bore</b>	1.3750 in 34.925 mm
<b>D - Cup Outer Diameter</b>	2.5625 in 65.088 mm

<b>B - Cone Width</b>	0.7200 in 18.288 mm
<b>C - Cup Width</b>	0.5500 in 13.970 mm
<b>T - Bearing Width</b>	0.7100 in 18.034 mm

#### Abutment and Fillet Dimensions

<b>R - Cone Backface "To Clear" Radius<sup>1</sup></b>	0.14 in 3.560 mm
<b>r - Cup Backface "To Clear" Radius<sup>2</sup></b>	0.050 in 1.27 mm
<b>da - Cone Frontface Backing Diameter</b>	1.63 in 41.40 mm
<b>db - Cone Backface Backing Diameter</b>	1.89 in 48.01 mm
<b>Da - Cup Frontface Backing Diameter</b>	2.44 in 61.00 mm
<b>Db - Cup Backface Backing Diameter</b>	2.28 in 57.91 mm
<b>Ab - Cage-Cone Frontface Clearance</b>	0.08 in 2 mm
<b>Aa - Cage-Cone Backface Clearance</b>	0.01 in 0.3 mm
<b>a - Effective Center Location<sup>3</sup></b>	-0.14 in -3.60 mm

#### Basic Load Ratings

<b>C90 - Dynamic Radial Rating (90 million revolutions)<sup>4</sup></b>	3760 lbf 16700 N
<b>C1 - Dynamic Radial Rating (1 million revolutions)<sup>5</sup></b>	14500 lbf 64600 N
<b>C0 - Static Radial Rating</b>	14200 lbf 63100 N
<b>C<sub>a90</sub> - Dynamic Thrust Rating (90 million revolutions)<sup>6</sup></b>	2430 lbf 10800 N

## Factors

<b>K - Factor<sup>7</sup></b>	1.55
<b>e - ISO Factor<sup>8</sup></b>	0.38
<b>Y - ISO Factor<sup>9</sup></b>	1.59
<b>G1 - Heat Generation Factor (Roller-Raceway)</b>	18
<b>G2 - Heat Generation Factor (Rib-Roller End)</b>	10.6
<b>Cg - Geometry Factor</b>	0.0666

<sup>1</sup> These maximum fillet radii will be cleared by the bearing corners.

<sup>2</sup> These maximum fillet radii will be cleared by the bearing corners.

<sup>3</sup> Negative value indicates effective center inside cone backface.

<sup>4</sup> Based on  $90 \times 10^6$  revolutions  $L_{10}$  life, for The Timken Company life calculation method.  $C_{90}$  and  $C_{a90}$  are radial and thrust values.

<sup>5</sup> Based on  $1 \times 10^6$  revolutions  $L_{10}$  life, for the ISO life calculation method.

<sup>6</sup> Based on  $90 \times 10^6$  revolutions  $L_{10}$  life, for The Timken Company life calculation method.  $C_{90}$  and  $C_{a90}$  are radial and thrust values for a single-row,  $C_{90(2)}$  is the two-row radial value.

<sup>7</sup> These factors apply for both inch and metric calculations. Consult your Timken representative for instruction on use.

<sup>8</sup> These factors apply for both inch and metric calculations. Consult your Timken representative for instruction on use.

<sup>9</sup> These factors apply for both inch and metric calculations. Consult your Timken representative for instruction on use.

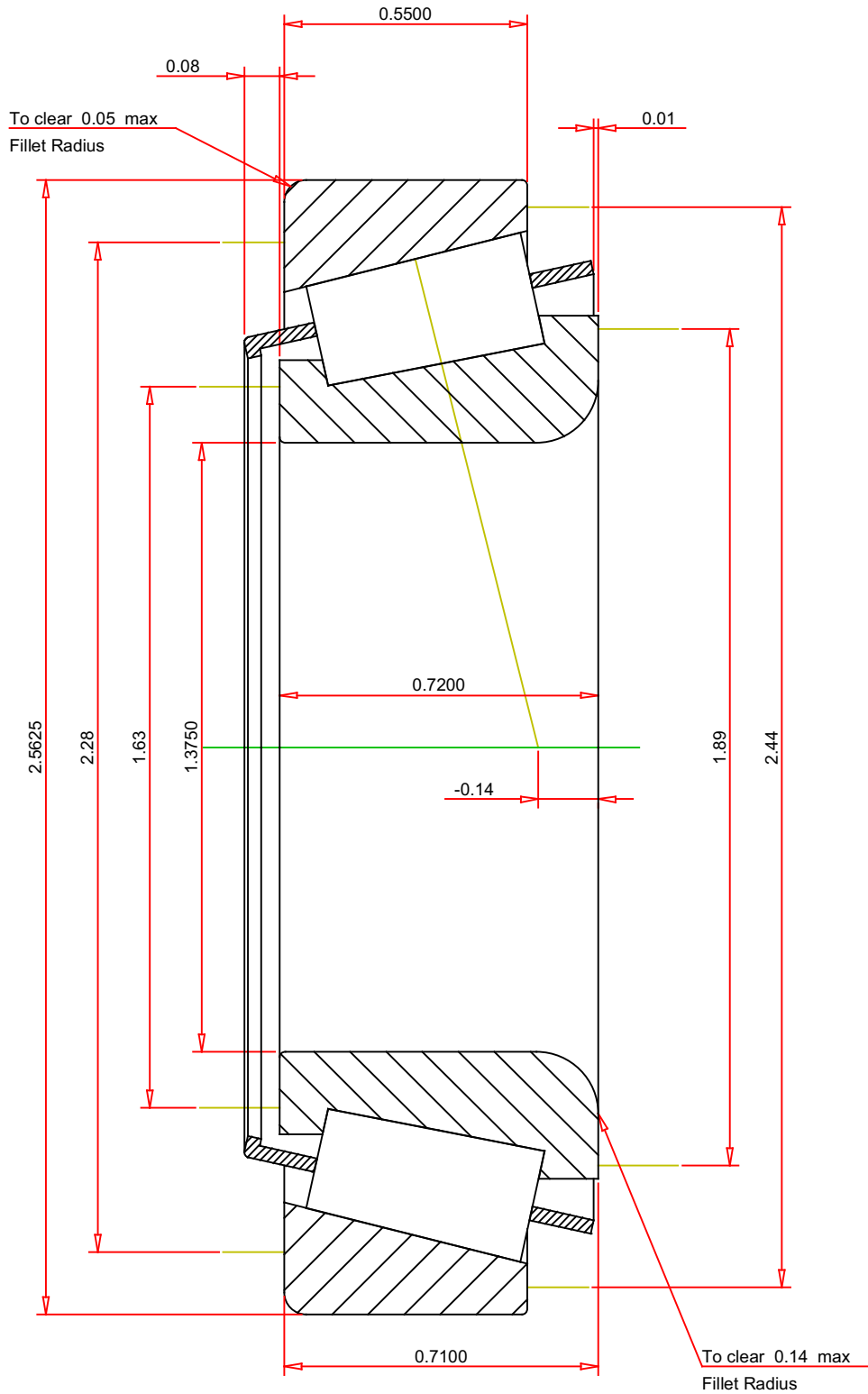

IMPERIAL UNITS

ISO Factor - e	0.38
ISO Factor - Y	1.59
Bearing Weight	0.5 lb
Number of Rollers Per Row	19
Effective Center Location	-0.14 inch

**TIMKEN**®

**THE TIMKEN COMPANY**  
NORTH CANTON, OHIO USA

**LM48548 - LM48510**  
TS BEARING ASSEMBLY

K Factor	1.55
Dynamic Radial Rating - C90	3760 lbf
Dynamic Thrust Rating - Ca90	2430 lbf
Static Radial Rating - C0	14200 lbf
Dynamic Radial Rating - C1	14500 lbf

Every reasonable effort has been made to ensure the accuracy of the information contained in this writing, but no liability is accepted for errors, omissions or for any other reason.

**FOR DISCUSSION ONLY**