

# Canon

## imageRUNNER

2545i / 2545 / 2535i / 2535

2530 / 2525i / 2525

2520i / 2520

### User's Guide



#### **Read this guide first.**

Please read this guide before operating this product.

After you finish reading this guide, store it in a safe place for future reference.

ENG

**imageRUNNER**

**2545i/2545**

**2535i/2535**

**2530/2525i**

**2525/2520i**

**2520**

**User's Guide**

# Manuals for the Machine

The manuals for this machine are organized as shown below. Please refer to them for detailed information. Some manuals may not be needed for certain system configurations and products purchased.



Guides with this symbol are printed manuals.



Guides with this symbol are PDF manuals included on the accompanying CD-ROM.

- **Quick Reference for Basic Operations**

**Easy Operation Guide**



- **Legal Notices**
- **Setup Instructions**

**User's Guide  
(This Document)**



- **Basic Operations**
- **Troubleshooting**

**Reference Guide**



- **Copying Instructions**

**Copying Guide**



- **Sending and Fax Instructions**

**Sending and Facsimile Guide**



- **Remote User Interface Instructions**

**Remote UI Guide**



- **Network Connectivity**
- **Security Management**

**System Settings Guide**



- **Color Network ScanGear Instructions**

**Network ScanGear Guide**



- **USB Memory Media Printing Instructions**
- **PS/PCL/UFRII LT Printer Instructions**

**Printer Guide**



- **Windows Printer Driver Instructions**

**Windows Printer Driver Guide**



- **Windows Fax Driver Instructions**

**Windows Fax Driver Guide**



- **Macintosh Printer Driver Instructions**

**Mac Printer Driver Guide**





# How This Manual Is Organized

**Chapter 1** Machine Installation

**Chapter 2** Before You Start Using the Machine

**Chapter 3** Accompanying CD-ROMs

**Chapter 4** Using the Basic Functions

**Chapter 5** Routine Maintenance

**Chapter 6** Troubleshooting

**Chapter 7** Appendix

Includes the descriptions of available paper stock and Index.

# Contents

---

<b>Preface</b> .....	<b>vii</b>
<b>How to Use This Manual</b> .....	<b>vii</b>
Symbols Used in This Manual .....	vii
Keys and Buttons Used in This Manual .....	viii
Illustrations Used in This Manual .....	viii
Displays Used in This Manual .....	ix
Abbreviations Used in This Manual .....	ix
Trademarks .....	x
Operations and Terms Used in the Manuals .....	x
Available Features .....	xii
<b>Legal Notices</b> .....	<b>xiii</b>
Product Name .....	xiii
Laser Safety .....	xiii
Additional Information .....	xiii
IPv6 Ready Logo .....	xiv
WEEE Directive/Rule .....	xv
Copyright .....	xvi
Third Party Software .....	xvi
Disclaimers .....	xvii
Legal Limitations on the Usage of Your Product and the Use of Images .....	xvii
Super G3 .....	xviii
<b>Important Safety Instructions</b> .....	<b>xix</b>
Installation .....	xix
Power Supply .....	xx
Handling .....	xxi
Maintenance and Inspections .....	xxiv
Consumables .....	xxvi
Other Warnings .....	xxvi

## Chapter 1 Machine Installation

---

<b>Installation Location and Handling</b> .....	<b>1-2</b>
Installation Precautions .....	1-2
Avoid Installing the Machine in the Following Locations .....	1-2
Select a Safe Power Supply .....	1-4
Provide Adequate Installation Space .....	1-6
Moving the Machine .....	1-6
Handling Precautions .....	1-7

<b>Cable Connection</b> .....	<b>1-9</b>
Using the Machine as a Local Printer (USB Connection) .....	1-9
Sharing the Machine with Other Network Users .....	1-10
Using Ethernet .....	1-10
Using the Machine as a Fax Device .....	1-12

## **Chapter 2 Before You Start Using the Machine**

---

<b>Turning ON/OFF the Machine</b> .....	<b>2-2</b>
Turning ON the Main Power .....	2-2
Using the Control Panel Power Switch (Sleep Mode) .....	2-4
Turning OFF the Main Power .....	2-4
<b>Setup Flow</b> .....	<b>2-5</b>

## **Chapter 3 Accompanying CD-ROMs**

---

<b>User Manual CD-ROM</b> .....	<b>3-2</b>
System Requirements .....	3-2
Using the CD-ROM Menu .....	3-3
<b>UFR II LT User Software</b> .....	<b>3-4</b>
Contents of CD-ROM .....	3-4
System Requirements .....	3-5
UFR II LT Printer Driver .....	3-5
Color Network ScanGear .....	3-6
Installation .....	3-7
<b>PCL User Software (Optional)</b> .....	<b>3-9</b>
Contents of CD-ROM .....	3-9
System Requirements .....	3-10
Installation .....	3-10
<b>PS User Software (Optional)</b> .....	<b>3-11</b>
Contents of CD-ROM .....	3-11
System Requirements .....	3-12
Installation .....	3-12
<b>Fax Driver Software (Optional)</b> .....	<b>3-14</b>
Contents of CD-ROM .....	3-14
System Requirements .....	3-15
Installation .....	3-15

## Chapter 4 Using the Basic Functions

---

<b>Making a Copy</b> .....	4-2
<b>Printing from a Computer</b> .....	4-4
<b>Printing from a USB Memory Media Device (Media Print)</b> .....	4-6
<b>Sending a Document (E-Mail, I-Fax, File Server, and USB Memory Media Device)</b> .....	4-8
<b>Sending a Fax</b> .....	4-10
<b>Scanning from a Computer (Remote Scan)</b> .....	4-12
<b>Operating the Machine from a Computer (Remote UI)</b> .....	4-14

## Chapter 5 Routine Maintenance

---

<b>Paper Drawers</b> .....	5-2
Loading Paper .....	5-3
Adjusting a Paper Drawer to Hold a Different Paper Size .....	5-5
<b>Replacing the Toner</b> .....	5-8
<b>Routine Cleaning</b> .....	5-13
Platen Glass and Cover .....	5-13
Feeder Scanning Area and Rollers .....	5-14
<b>Consumables</b> .....	5-18
Paper Stock .....	5-18
Toner .....	5-19
Be careful of counterfeit toners .....	5-19
Stamp Ink Cartridge .....	5-20
Staple Cartridge .....	5-20

## Chapter 6 Troubleshooting

---

<b>Clearing Paper Jams</b> .....	6-2
Fixing Unit .....	6-3
Paper Drawers 1 and 2 .....	6-5
Feeder .....	6-9
<b>Service Call Message</b> .....	6-12
Restarting the Machine .....	6-12
Using the Machine with Limited Functions .....	6-13
Requesting Repairs from the Control Panel .....	6-14
Contacting Your Local Authorized Canon Dealer .....	6-16

## Chapter 7 Appendix

---

<b>Available Paper Stock</b> .....	7-2
<b>Index</b> .....	7-4

# Preface





Thank you for purchasing the Canon imageRUNNER 2545i/2545/2535i/2535/2530/2525i/2525/2520i/2520. Please read this manual thoroughly before operating the machine to familiarize yourself with its capabilities, and to make the most of its many functions. After reading this manual, store it in a safe place for future reference.

## How to Use This Manual

---

### Symbols Used in This Manual

The following symbols are used in this manual to explain procedures, restrictions, handling precautions, and instructions that should be observed for safety.

-  **WARNING** Indicates a warning concerning operations that may lead to death or injury to persons if not performed correctly. To use the machine safely, always pay attention to these warnings.
-  **CAUTION** Indicates a caution concerning operations that may lead to injury to persons if not performed correctly. To use the machine safely, always pay attention to these cautions.
-  **IMPORTANT** Indicates operational requirements and restrictions. Be sure to read these items carefully to operate the machine correctly, and avoid damage to the machine or property.
-  **NOTE** Indicates a clarification of an operation, or contains additional explanations for a procedure. Reading these notes is highly recommended.
-  Indicates an operation that must not be performed. Read these items carefully, and make sure not to perform the described operations.



## Keys and Buttons Used in This Manual

The following tables provide a few examples of how keys, buttons, and other user interfaces such as icons displayed on the screen are expressed in this manual:

- Keys on the machine's control panel and touch panel display:

	Keys	Example
<b>Control Panel</b>	Key icon + (Key Name)	 (Additional Functions)
<b>Touch Panel Display</b>	[Key Name]	[OK], [Cancel], etc.
	[Key Icon]	[▼], [▲], etc.

- Buttons, icons and other user interfaces on computer operation screens:

Buttons, Icons, and Others	Example
[Button Name]	[OK]
[Name] + icon, menu, etc.	[CD-ROM] icon, [Start] menu, etc.

## Illustrations Used in This Manual

The machine illustrations used in this manual are those of the imageRUNNER 2545i with the following optional equipment attached: the Inner Finisher-B1, Inner Finisher Additional Tray-B1, and CST. Feeding Unit-AE1.

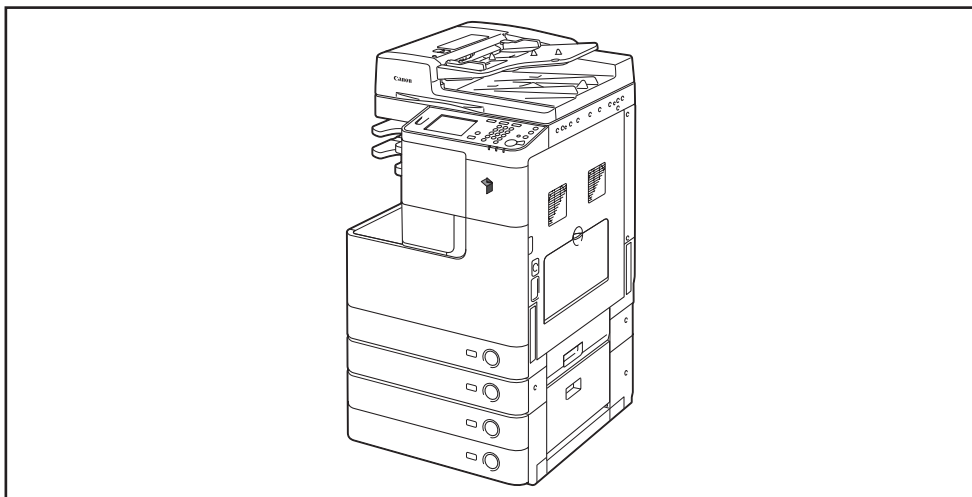

## Displays Used in This Manual

Screen shots used in this manual may differ from actual displays depending on the machine configuration.

The keys and buttons to be pressed or clicked are marked with a , as shown below.

When multiple keys or buttons can be pressed or clicked, all of them will be marked. Select the keys or buttons best suited to your needs.

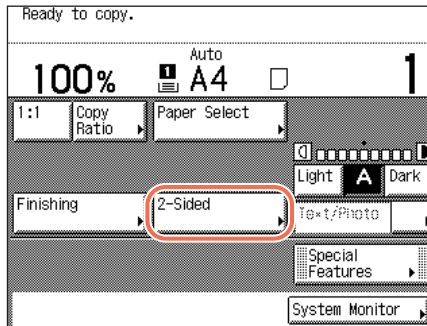

## Abbreviations Used in This Manual

In this manual, product names are abbreviated as follows:

Microsoft Windows 2000 operating system:	Windows 2000
Microsoft Windows XP operating system:	Windows XP
Microsoft Windows Vista operating system:	Windows Vista
Microsoft Windows 7 operating system:	Windows 7
Microsoft Windows Server 2003 operating system:	Windows Server 2003
Microsoft Windows Server 2008 operating system:	Windows Server 2008
Microsoft Windows operating system:	Windows

## Trademarks

Macintosh and Mac OS are trademarks of Apple Inc., registered in the U.S. and other countries.

Microsoft, Windows, Windows Vista, Windows Server, Excel and PowerPoint are either registered trademarks or trademarks of Microsoft Corporation in the United States and/or other countries.

Other product and company names herein may be the trademarks of their respective owners.

## Operations and Terms Used in the Manuals

This machine makes effective use of memory to perform print operations efficiently. For example, as soon as the machine has scanned the original that you want to copy, it can immediately scan the next person's original. You can also print from this machine, using a function other than the Copy function. In this machine, these operations take place in a complex way, so that not only copies, but also various kinds of prints may sometimes have to wait their turn before they can be printed.

To avoid confusion when reading the manuals, the terms, "scanning," "printing," and "copying," used throughout the manuals are defined below. When making a copy, the process of scanning originals and printing copies may be described as separate functions.

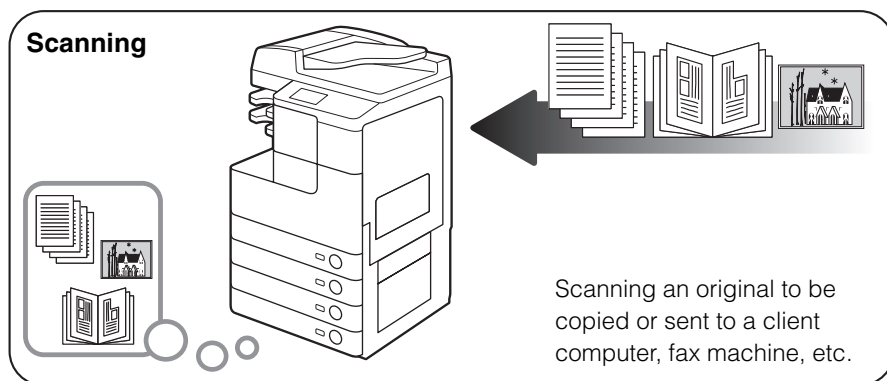

## Printing



Outputting documents such as a copy, fax, or data sent from a client computer to the machine.

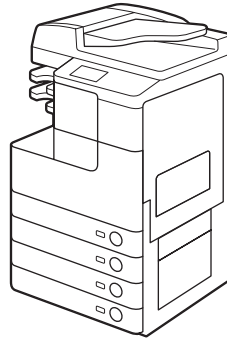

## Copying

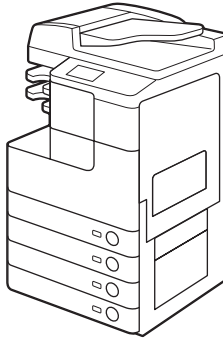

Printing data scanned from an original, followed by finishing options, such as stapling.

## Available Features

The procedures described in the manuals assume the machine fully equipped with the optional equipment. Depending on the system configuration and product purchased, some features described in the manuals may not be functional. The table below shows the available features on a product basis.

✓: Standard equipped

opt.: Optional

Model	Copy/ Remote Scan/ Remote UI	Send	Fax	Print				Feeder	Drawer		Searchable PDF
				USB/ UFR II LT	PCL	PS	Barcode		2	3 & 4	
imageRUNNER 2545i	✓	✓	opt.	✓	opt.	opt.	opt.	✓	✓	opt.	opt.
imageRUNNER 2545	✓	opt.	opt.	✓	opt.	opt.	opt.	opt.	✓	opt.	opt.
imageRUNNER 2535i	✓	✓	opt.	✓	opt.	opt.	opt.	✓	✓	opt.	opt.
imageRUNNER 2535	✓	opt.	opt.	✓	opt.	opt.	opt.	opt.	✓	opt.	opt.
imageRUNNER 2530	✓	opt.	opt.	✓	opt.	opt.	opt.	opt.	✓	opt.	opt.
imageRUNNER 2525i	✓	✓	opt.	✓	opt.	opt.	opt.	✓	✓	opt.	opt.
imageRUNNER 2525	✓	opt.	opt.	✓	opt.	opt.	opt.	opt.	✓	opt.	opt.
imageRUNNER 2520i	✓	✓	opt.	✓	opt.	opt.	opt.	✓	opt.	opt.	opt.
imageRUNNER 2520	✓	opt.	opt.	✓	opt.	opt.	opt.	opt.	opt.	opt.	opt.

### NOTE

For more information on the optional equipment, see Chapter 4, “Optional Equipment,” in the *Reference Guide*.

# Legal Notices

---

## Product Name

Safety regulations require the product's name to be registered. In some regions where this product is sold, the following name(s) in ( ) may be registered instead.

imageRUNNER 2545i/2545/2535i/2535 (F190300)

imageRUNNER 2525i (F190700)

imageRUNNER 2530/2525/2520i/2520 (F190800)

## Laser Safety

This product is certified as a Class 1 laser product under IEC60825-1:2007 and EN60825-1:2007. This means that the product does not produce hazardous laser radiation.

Since radiation emitted inside the product is completely confined within protective housings and external covers, the laser beam cannot escape from the machine during any phase of user operation. Do not remove protective housings or external covers, except as directed by the equipment's manual.

## Additional Information

When servicing or adjusting the optical system of the product, be careful not to place screwdrivers or other shiny objects in the path of the laser beam. Also, accessories such as watches and rings should be removed before working on the product. The reflected beam, whether visible or invisible, can permanently damage your eyes.

The labels shown below are attached to the machine's internal part and next to the waste toner container behind the front cover.



**DANGER** - Invisible laser radiation when open.  
AVOID DIRECT EXPOSURE TO BEAM.

**CAUTION** - CLASS 3B INVISIBLE LASER RADIATION WHEN OPEN AVOID EXPOSURE TO THE BEAM.

**ATTENTION** - RAYONNEMENT LASER INVISIBLE DE CLASSE 3B EN CAS D'OUVERTURE EVITEZ L'EXPOSITION AU FAISCEAU

**VORSICHT** - UNSICHTBARE LASERSTRAHLUNG KLASSE 3B, WENN ABDECKUNG GEÖFFNET. NICHT DEM STRAHL AUSSETZEN

**PRECAUCIÓN** - RADIACIÓN LASER INVISIBLE DE CLASE 3B PRESENTE AL ABRIR. EVITE LA EXPOSICIÓN AL HAZ.

**VAROITUS** - OSYNLIG LASERSTRÅLNING KLAS 3B VID ÖPPEN LUCKA UNDVIK EXPONERING FÖR LASERSTRÅLNING

**VARNING** - OSYNLIG LASERSTRÅLNING KLAS 3B VID ÖPPEN LUCKA OCH FÖRREGLINGAR URKOPPLADE UNDVIK EXPONERING FÖR LASERSTRÅLNINGEN

**注意** - 打开时, 存在不可见的3B类激光辐射, 请避免接触该激光束

**注意** - 打開機器蓋板時有3B級不可視雷射光釋出, 應避免曝射

**주의** - 열리면 등급 3B 비가시 레이저 방사선이 방출됩니다. 광선에 노출을 피하십시오.

**注意** - ここを開くとクラス3B不可視レーザー放射が出ます。ビームに身をさらさないこと。

FU6-8881



**DANGER** - Invisible laser radiation when open.  
AVOID DIRECT EXPOSURE TO BEAM.

**CAUTION** - CLASS 3B INVISIBLE LASER RADIATION WHEN OPEN. AVOID EXPOSURE TO THE BEAM.

**ATTENTION** - RAYONNEMENT LASER INVISIBLE DE CLASSE 3B EN CAS D'OUVERTURE. EVITEZ L'EXPOSITION AU FAISCEAU.

**VORSICHT** - UNSICHTBARE LASERSTRAHLUNG KLASSE 3B, WENN ABDECKUNG GEÖFFNET. NICHT DEM STRAHL AUSSETZEN.

**PRECAUCIÓN** - RADIACIÓN LASER INVISIBLE DE CLASE 3B PRESENTE AL ABRIR. EVITE LA EXPOSICIÓN AL HAZ.

**VAROITUS** - LUOKAN 3B NÄKYMÄTÖMÄLLE LASER-SÄTEILYÄ AVATTUNA. VÄLTÄ ALTISTUMISTA SÄTEELLE.

**注意** - 打开时, 存在不可见的3B类激光辐射, 请避免接触该激光束

**注意** - 打開機器蓋板時有3B級不可視雷射光釋出, 應避免曝射

**주의** - 열리면 등급 3B 비가시 레이저 방사선이 방출됩니다. 광선에 노출을 피하십시오.

**注意** - ここを開くとクラス3B不可視レーザー放射が出ます。ビームに身をさらさないこと。



FU6-8880

This product has been classified under IEC60825-1:2007 and EN60825-1:2007, which conform to the following classes:

**CLASS 1 LASER PRODUCT**  
**LASER KLASSE 1**  
**APPAREIL À LASER DE CLASSE 1**  
**APPARECCHIO LASER DI CLASSE 1**  
**PRODUCTO LÁSER DE CLASE 1**  
**APARELHO A LASER DE CLASSE 1**  
**LUOKAN 1 LASER-TUOTE**  
**LASERPRODUKT KLAS 1**

 **CAUTION**

Use of controls, adjustments, or performance of procedures other than those specified in the manuals may result in hazardous radiation exposure.

## IPv6 Ready Logo



The protocol stack included in this machine has obtained the IPv6 Ready Logo Phase-1 established by the IPv6 Forum.

## WEEE Directive / Rule



-European Union (and EEA) only-

This symbol attached on the product is according to the WEEE Directive (2002/96/EC).



-India only-

This product is not to be disposed of with your household waste, according to the e-waste (Management and Handling) Rules, 2011. This product should be handed over to a designated collection point, e.g., to an authorized collection site for recycling waste electrical and electronic equipment (EEE). Improper handling of this type of waste could have a possible negative impact on the environment and human health due to potentially hazardous substances that are generally associated with EEE. At the same time, your cooperation in the correct disposal of this product will contribute to the effective usage of natural resources. For more information regarding return and recycling of WEEE products, please visit <http://www.canon.co.in/environment> .

Also, this product complies with the "India E-waste Rule 2011" and prohibits use of lead, mercury, hexavalent chromium, polybrominated biphenyls or polybrominated diphenyl ethers in concentrations exceeding 0.1 % by weight and 0.01 % by weight for Cadmium, except for the exemptions set in Schedule II of the Rule.



# Copyright

Copyright 2012 by Canon Inc. All rights reserved.

No part of this publication may be reproduced or transmitted in any form or by any means, electronic or mechanical, including photocopying and recording, or by any information storage or retrieval system without the prior written permission of Canon Inc.

## Third Party Software

### **Third Party Software**

A. This product includes third-party software modules. Use and distribution of this software modules (the “SOFTWARE”) are subject to conditions (1) through (9) below.

- (1) You agree that you will comply with any applicable export control laws, restrictions or regulations of the countries involved in the event that this product including the SOFTWARE is shipped, transferred or exported into any country.
- (2) Rights holders of the SOFTWARE retain in all respects the title, ownership and intellectual property rights in and to the SOFTWARE. Except as expressly provided herein, no license or right, expressed or implied, is hereby conveyed or granted by rights holders of the SOFTWARE to you for any intellectual property of rights holders of the SOFTWARE.
- (3) You may use the SOFTWARE solely for use with the Canon product you purchased (the “PRODUCT”).
- (4) You may not assign, sublicense, market, distribute, or transfer the SOFTWARE to any third party without prior written consent of rights holders of the SOFTWARE.
- (5) Notwithstanding the foregoing, you may transfer the SOFTWARE only when (a) you assign all of your rights to the PRODUCT and all rights and obligations under the conditions to transferee and (b) such transferee agrees to be bound by all these conditions.
- (6) You may not decompile, reverse engineer, disassemble or otherwise reduce the code of the SOFTWARE to human readable form.
- (7) You may not modify, adapt, translate, rent, lease or loan the SOFTWARE or create derivative works based on the SOFTWARE.
- (8) You are not entitled to remove or make separate copies of the SOFTWARE from the PRODUCT.
- (9) The human-readable portion (the source code) of the SOFTWARE is not licensed to you.

## Disclaimers

The information in this document is subject to change without notice.

CANON INC. MAKES NO WARRANTY OF ANY KIND WITH REGARD TO THIS MATERIAL, EITHER EXPRESS OR IMPLIED, EXCEPT AS PROVIDED HEREIN, INCLUDING WITHOUT LIMITATION, THEREOF, WARRANTIES AS TO MARKETABILITY, MERCHANTABILITY, FITNESS FOR A PARTICULAR PURPOSE OR USE OR NON-INFRINGEMENT. CANON INC. SHALL NOT BE LIABLE FOR ANY DIRECT, INCIDENTAL, OR CONSEQUENTIAL DAMAGES OF ANY NATURE, OR LOSSES OR EXPENSES RESULTING FROM THE USE OF THIS MATERIAL.

## Legal Limitations on the Usage of Your Product and the Use of Images

Using your product to scan, print or otherwise reproduce certain documents, and the use of such images as scanned, printed or otherwise reproduced by your product, may be prohibited by law and may result in criminal and/or civil liability. A non-exhaustive list of these documents is set forth below. This list is intended to be a guide only. If you are uncertain about the legality of using your product to scan, print or otherwise reproduce any particular document, and/or of the use of the images scanned, printed or otherwise reproduced, you should consult, in advance, with your legal advisor for guidance.

- Paper Money
- Money Orders
- Certificates of Deposit
- Postage Stamps  
(canceled or uncanceled)
- Identifying Badges or Insignias
- Selective Service or Draft Papers
- Checks or Drafts Issued by  
Governmental Agencies
- Motor Vehicle Licenses and  
Certificates of Title
- Travelers Checks
- Food Stamps
- Passports
- Immigration Papers
- Internal Revenue Stamps  
(canceled or uncanceled)
- Bonds or Other Certificates of  
Indebtedness
- Stock Certificates
- Copyrighted Works/Works of Art  
without Permission of Copyright  
Owner



Super G3 is a phrase used to describe the new generation of fax machines that use ITU-T V.34 standard 33.6 Kbps\* modems. Super G3 High Speed Fax machines allow transmission times of approximately 3 seconds\* per page which results in reduced telephone line charges.

\* Approximately 3 seconds per page fax transmission time based on CCITT/ITU-T No.1 Chart, (JBIG, Standard Mode) at 33.6 Kbps modem speed. The PSTN (Public Switched Telephone Network) currently supports 28.8 Kbps modem speeds or slower, depending on telephone line conditions.

# Important Safety Instructions

---

Please read these “Important Safety Instructions” thoroughly before operating the machine. As these instructions are intended to prevent injury to the user or other persons or destruction of property, always pay attention to these instructions. Also, since it may result in unexpected accidents or injuries, do not perform any operation unless otherwise specified in the manuals. Improper operation or use of this machine could result in personal injury and/or damage requiring extensive repair that may not be covered under your Limited Warranty.

## Installation

### WARNING

- **Never block the ventilation slots and louvers on the machine. These openings are provided for proper ventilation of working parts inside the machine. Blocking these openings can cause the machine to overheat. Never place the machine on a soft surface, such as a sofa or rug.**
- **Do not install the machine in the following locations:**
  - **A damp or dusty location**
  - **A location near water faucets or water**
  - **A location exposed to direct sunlight**
  - **A location subject to high temperatures**
  - **A location near open flames**
- **Do not install the machine near alcohol, paint thinner, or other flammable substances. If flammable substances come into contact with electrical parts inside the machine, it may result in a fire or electrical shock.**

- Do not place the following items on the machine. If these items come into contact with a high-voltage area inside the machine, it may result in a fire or electrical shock. If these items are dropped or spilled inside the machine, immediately turn OFF the main power switch, and disconnect the power cord from the power outlet. Then, contact your local authorized Canon dealer.
  - Necklaces and other metal objects
  - Cups, vases, flowerpots, and other containers filled with water or liquids

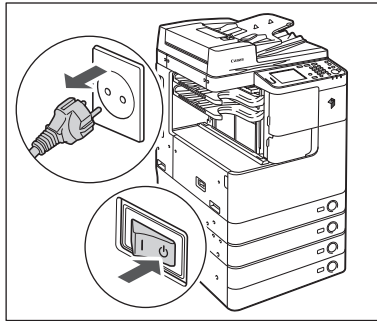

**⚠ CAUTION**

- Do not install the machine in unstable locations, such as unsteady platforms or inclined floors, or in locations subject to excessive vibrations, as this may cause the machine to fall or tip over, resulting in personal injury.
- Do not remove the machine's leveling feet after the machine has been installed, as this may cause the machine to fall or tip over, resulting in personal injury.

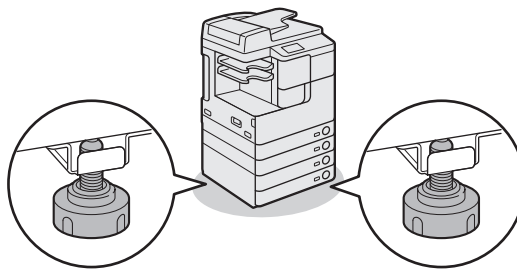

## Power Supply

**⚠ WARNING**

- Do not damage or modify the power cord. Also, do not place heavy objects on the power cord, or pull on or excessively bend it, as this could cause electrical damage and result in a fire or electrical shock.
- Keep the power cord away from a heat source; failure to do this may cause the power cord coating to melt, resulting in a fire or electrical shock.
- Do not connect or disconnect the power cord with wet hands, as this may result in electrical shock.

- Do not connect the power cord to a multiplug power strip, as this may cause a fire or electrical shock.
- Do not bundle up or tie the power cord in a knot, as this may result in a fire or electrical shock.
- Insert the power plug completely into the power outlet, as failure to do so may result in a fire or electrical shock.
- Do not use power cords other than the power cord provided, as this may result in a fire or electrical shock.
- As a general rule, do not use extension cords. Using an extension cord may result in a fire or electrical shock. If an extension cord must be used, however, use one rated for voltages of 220 - 240 V AC and over, untie the cord binding, and insert the power plug completely into the extension cord outlet to ensure a firm connection between the power cord and the extension cord.
- Do not use power supplies with voltages other than those specified herein, as this may result in a fire or electrical shock.
- Always grasp the power plug when disconnecting the power cord. Pulling on the power cord may expose or snap the core wire, or otherwise damage the power cord. If the power cord is damaged, this could cause current to leak, resulting in a fire or electrical shock.



#### IMPORTANT

Leave sufficient space around the power plug so that it can be unplugged easily. If objects are placed around the power plug, you will be unable to unplug it in an emergency.

## Handling



#### WARNING

- Do not attempt to disassemble or modify the machine. There are high-temperature and high-voltage components inside the machine which may result in a fire or electrical shock.
- If the machine makes strange noises, or gives off smoke, heat, or strange smells, immediately turn OFF the main power switch, and disconnect the power cord from the power outlet. Then, contact your local authorized Canon dealer. Continued use of the machine in this condition may result in a fire or electrical shock.
- Do not use highly flammable sprays near the machine. If gas from these sprays comes into contact with the electrical components inside the machine, it may result in a fire or electrical shock.
- To avoid damage to the power cord and creating a fire hazard, always turn OFF the main power switch, and unplug the interface cable when moving the machine. Otherwise, the power cord or interface cable may be damaged, resulting in a fire or electrical shock.
- Make sure that the power plug is firmly inserted into the power outlet if the machine was moved. Do not use the machine while the connection is loose, as doing so may cause a fire.

- Do not drop paper clips, staples, or other metal objects inside the machine. Also, do not spill water, liquids, or flammable substances (alcohol, benzene, paint thinner, etc.) inside the machine. If these items come into contact with a high-voltage area inside the machine, it may result in a fire or electrical shock. If these items are dropped or spilled inside the machine, immediately turn OFF the main power switch, and disconnect the power cord from the power outlet. Then, contact your local authorized Canon dealer.

**⚠ CAUTION**

- Do not place heavy objects on the machine, as they may tip over and fall resulting in personal injury.
- Close the feeder/platen cover gently to avoid catching your hands, as this may result in personal injury.

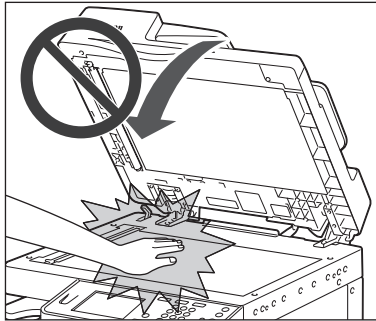

- Do not press down hard on the feeder/platen cover when using the platen glass to make copies of thick books. Doing so may damage the platen glass and result in personal injury.
- Do not place your hands, hair, clothing, etc., near the exit and feed rollers. Even if the machine is not in operation, your hands, hair, or clothing may get caught in the rollers, which may result in personal injury or damage if the machine suddenly starts printing.
- Paper that has just been output from the machine may be hot. Be careful when removing or aligning paper from the output tray. Touching paper right after it is output may result in low-temperature burns.
- Do not touch the finisher while the machine is printing, as this may result in personal injury.

- Do not place your hand in the following parts of the finisher, as this may result in personal injury:
  - Trays
  - Stapler unit (where stapling is performed)
  - Rollers
  - Spaces between the trays and the main unit

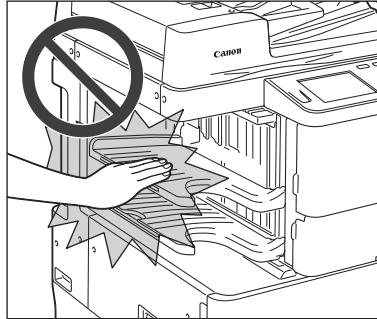

Inner Finisher-B1

- The laser beam can be harmful to human bodies. Since radiation emitted inside the product is completely confined within protective housings and external covers, the laser beam cannot escape from the machine during any phase of user operation. Read the following remarks and instructions for safety.
  - Never open covers other than those instructed in the manuals.
  - Do not remove the following caution labels which are attached to the machine. If the labels have been removed, contact your local authorized Canon dealer.

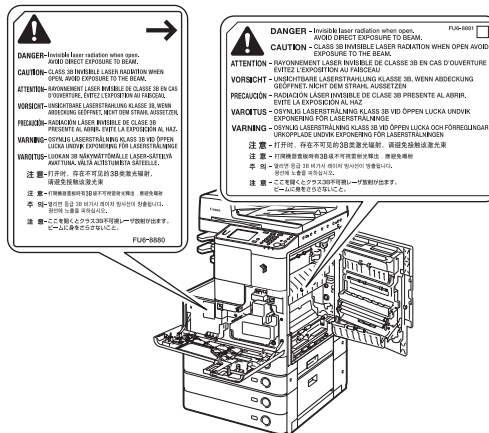

- If the laser beam escapes from the machine, exposure may cause serious damage to your eyes.
- Controlling, adjusting, or operating the machine in ways not mentioned in the manuals for this machine may cause dangerous radiation to escape from the machine.





## IMPORTANT

Turn OFF the control panel power switch for safety when the machine will not be used for a long period of time, such as overnight. Also, turn OFF the main power switch, and disconnect the power cord for safety when the machine will not be used for an extended period of time, such as during consecutive holidays.

## Maintenance and Inspections



### WARNING

- When cleaning the machine, first turn OFF the main power switch, then disconnect the power cord. Failure to observe these steps may result in a fire or electrical shock.
- Disconnect the power cord from the power outlet regularly, and clean the area around the base of the power plug's metal pins and the power outlet with a dry cloth to ensure that all dust and grime is removed. If the power cord is connected for a long period of time in a damp, dusty, or smoky location, dust can build up around the power plug and become damp. This may cause a short circuit and result in a fire.
- Clean the machine using a slightly dampened cloth with a mild detergent mixed with water. Do not use alcohol, benzene, paint thinner, or other flammable substances. Check detergent for flammability prior to use. If flammable substances come into contact with a high-voltage area inside the machine, it may result in a fire or electrical shock.
- There are some areas inside the machine which are subject to high-voltages. When removing jammed paper or when inspecting the inside of the machine, do not allow necklaces, bracelets, or other metal objects to touch the inside of the machine, as this may result in burns or electrical shock.
- Do not burn or throw used toner cartridges into open flames, as this may cause the toner remaining inside the cartridges to ignite, resulting in burns or a fire.
- If you accidentally spill or scatter toner, carefully gather the toner particles together or wipe them up with a soft, damp cloth in a way that prevents inhalation. Never use a vacuum cleaner that does not have safeguards against dust explosions to clean up spilled toner. Doing so may cause a malfunction in the vacuum cleaner, or result in a dust explosion due to static discharge.
- Make sure that the power plug is firmly inserted into the power outlet after cleaning the machine. Do not use the machine while the connection is loose, as doing so may cause a fire.
- Check the power cord and power plug regularly. If the following conditions occur, contact your local authorized Canon dealer, as the condition may cause a fire:
  - There are burn marks on the power plug.
  - The blade on the power plug is deformed or broken.
  - The power goes OFF and ON when the power cord is bent.
  - There are cuts, cracks, or indentations on the power cord.
  - A part of the power cord becomes hot.

- Check the power cord and power plug regularly to make sure that they are not handled in the following manner, as this may result in a fire or electrical shock:
  - The connection part of the power plug is loose.
  - Stress is being applied to the power cord by a heavy object or by affixing it with staples.
  - The power plug is loose.
  - The power cord is tied in a bundle.
  - The power cord protrudes into a walkway.
  - The power cord is in front of a heater.

### CAUTION

- The fixing unit and its surroundings inside the machine may become hot during use. When removing jammed paper or when inspecting the inside of the machine, do not touch the fixing unit and its surroundings, as doing so may result in burns or electrical shock.

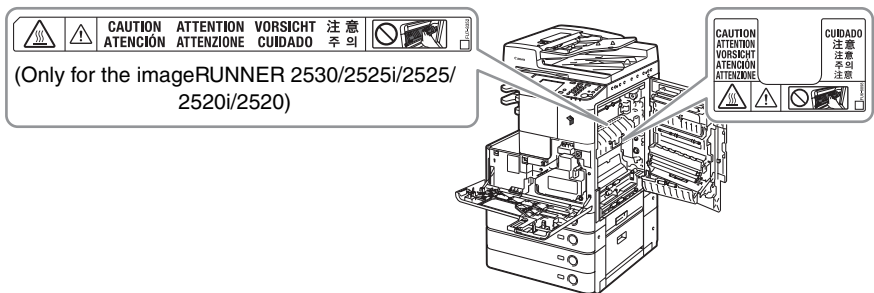

- When removing jammed paper or when inspecting the inside of the machine, do not expose yourself to the heat emitted from the fixing unit and its surroundings for a prolonged period of time. Doing so may result in low temperature burns, even if you do not touch the fixing unit and its surroundings directly.
- When removing jammed paper or replacing the toner cartridge, take care not to allow the toner to come into contact with your hands or clothing, as this will dirty your hands or clothing. If they become dirty, wash immediately with cold water. Washing with warm water will set the toner, and make it impossible to remove the toner stains.
- When removing paper which has become jammed inside the machine, remove the jammed paper gently to prevent the toner on the paper from scattering and getting into your eyes or mouth. If the toner gets into your eyes or mouth, wash immediately with cold water and immediately consult a physician.
- When loading paper or removing jammed originals or paper, take care not to cut your hands on the edges of the originals or paper.
- When removing paper which has become jammed inside the machine, take care not to cut your hands or injure yourself on the inside of the machine. If you cannot remove the paper, contact your local authorized Canon dealer.
- When removing a used toner cartridge, remove the cartridge carefully to prevent the toner from scattering and getting into your eyes or mouth. If the toner gets into your eyes or mouth, wash immediately with cold water and immediately consult a physician.

- Do not dismantle the toner cartridge, as doing so may cause the toner to fly out and enter your eyes or mouth. If the toner gets into your eyes or mouth, wash immediately with cold water and immediately consult a physician.
- If toner escapes from the toner cartridge, make sure not to ingest the toner or allow it to directly touch your skin. If toner touches your skin, wash it away with soap and water. If your skin still feels irritated after washing it, or you ingest toner, consult a doctor immediately.

## Consumables

### WARNING

- Do not burn or throw used toner cartridges into open flames, as this may cause the toner remaining inside the cartridges to ignite, resulting in burns or a fire.
- Do not store toner cartridges or paper in places exposed to open flames, as this may cause the toner or paper to ignite, resulting in burns or a fire.
- If you accidentally spill or scatter toner, carefully gather the toner particles together or wipe them up with a soft, damp cloth in a way that prevents inhalation. Never use a vacuum cleaner that does not have safeguards against dust explosions to clean up spilled toner. Doing so may cause a malfunction in the vacuum cleaner, or result in a dust explosion due to static discharge.

### CAUTION

- Keep toner and other consumables out of the reach of small children. If these items are ingested, consult a physician immediately.
- Do not dismantle the toner cartridge, as doing so may cause the toner to fly out and enter your eyes or mouth. If toner gets into your eyes or mouth, wash immediately with cold water and immediately consult a physician.
- If toner escapes from the toner cartridge, make sure not to ingest the toner or allow it to directly touch your skin. If toner touches your skin, wash it away with soap and cold water. If your skin still feels irritated after washing it, or you ingest toner, consult a doctor immediately.
- When discarding used toner cartridges, put the cartridges into a bag to prevent the toner remaining inside the cartridges from scattering, and dispose of them in a location away from open flames.

## Other Warnings

### WARNING

For cardiac pacemaker users:

This product emits low level magnetic flux. If you use a cardiac pacemaker and feel abnormalities, please move away from the product and consult your doctor.

# Machine Installation

# 1

## CHAPTER

This chapter describes the precautions for installing the machine and describes how to connect the cables.

---

<b>Installation Location and Handling</b> . . . . .	<b>1-2</b>
Installation Precautions . . . . .	1-2
Handling Precautions. . . . .	1-7
<b>Cable Connection</b> . . . . .	<b>1-9</b>
Using the Machine as a Local Printer (USB Connection) . . . . .	1-9
Sharing the Machine with Other Network Users . . . . .	1-10
Using the Machine as a Fax Device. . . . .	1-12

# Installation Location and Handling

This section describes precautions for the installation location and handling. Read this section prior to using the machine.

## Installation Precautions

### *Avoid Installing the Machine in the Following Locations*

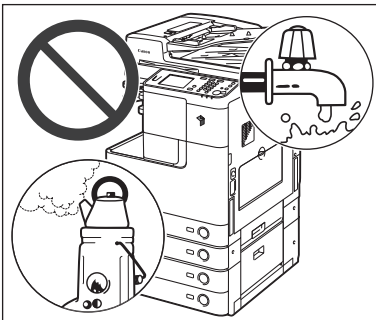

- **Avoid locations subject to temperature and humidity extremes, whether low or high.**

For example, avoid installing the machine near water faucets, hot water heaters, humidifiers, air conditioners, heaters or stoves.

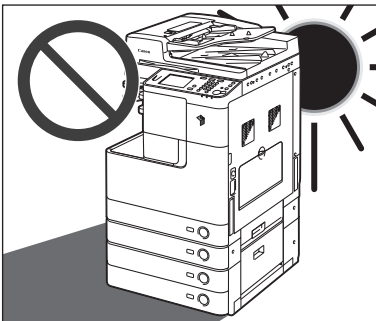

- **Avoid installing the machine in direct sunlight.**

If this is unavoidable, use curtains to shade the machine. Be sure that curtains do not block the machine's ventilation slots or louvers, or interfere with the electrical cord or power supply.

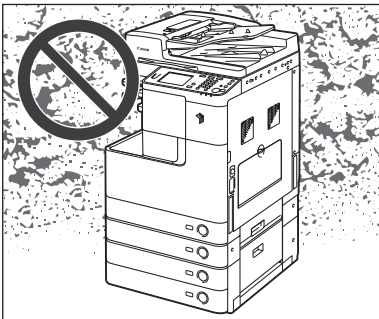
**■ Avoid poorly ventilated locations.**

This machine generates a slight amount of ozone or other odors during normal use. Although sensitivity to ozone or other odors may vary, this amount is not harmful. Ozone or other odors may be more noticeable during extended use or long production runs, especially in poorly ventilated rooms. It is recommended that the room be appropriately ventilated, sufficient to maintain a comfortable working environment, in areas of machine operation.

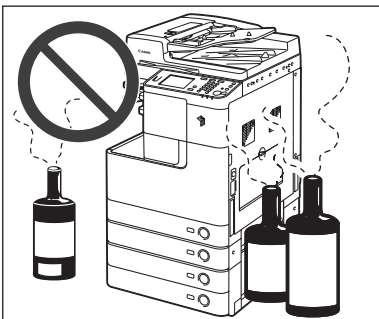
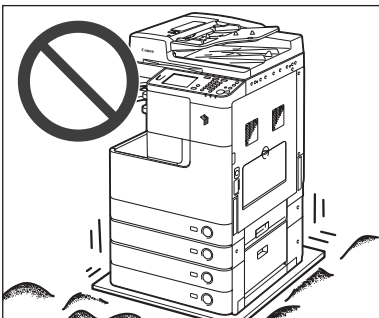
**■ Avoid locations where ammonia gas is emitted.****■ Avoid locations that are subject to vibration.**

For example, avoid installing the machine on unstable floors or stands.

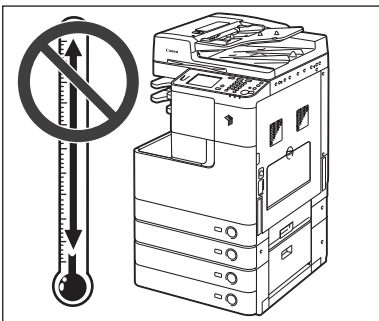
**■ Avoid exposing the machine to rapid changes in temperature.**

If the room in which the machine is installed is cold but rapidly heated, water droplets (condensation) may form inside the machine. This may result in a noticeable degradation in the quality of the printed image, the inability to properly scan an original, or the outputs having no printed image at all.

- **Avoid locations where a considerable amount of dust accumulates.**
- **Avoid locations near volatile or flammable materials, such as alcohol or paint thinner.**
- **Avoid installing the machine near computers or other precision electronic equipment.**

Electrical interference and vibrations generated by the machine during printing can adversely affect the operation of such equipment.
- **Avoid installing the machine near televisions, radios, or similar electronic equipment.**

The machine may interfere with sound and picture signal reception. Insert the power plug into a dedicated power outlet, and maintain as much space as possible between the machine and other electronic equipment.
- **Do not remove the machine's leveling feet.**

Do not remove the machine's leveling feet after the machine has been installed. If you put weight on the front of the machine while the drawers or units within the machine are pulled out, the machine may fall forward. To prevent this from happening, make sure that the machine's leveling feet are in place.
- **Contact an authorized Canon dealer if communication is unavailable.**

Depending on your locale or your telephone connection, you may be unable to perform data communication. In this case, contact your local authorized Canon dealer.

### *Select a Safe Power Supply*

- **Plug the machine into a standard 220 - 240 V AC, three-wire grounded outlet.**
- **Make sure that the power supply for the machine is safe, and has a steady voltage.**
- **Do not connect other electrical equipment to the same power outlet to which the machine is connected.**
- **Do not connect the power cord to a multiplug power strip, as this may cause a fire or electrical shock.**

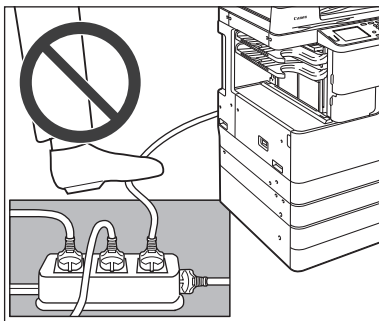

- **The power cord may become damaged if it is often stepped on or if heavy objects are placed on it. Continued use of a damaged power cord can lead to an accident, such as a fire or electrical shock.**
- **The power cord should not be taut, as this may lead to a loose connection and cause overheating, which could result in a fire.**

- **If excessive stress is applied to the connection part of the power cord, it may damage the power cord or the wires inside the machine may disconnect. This could result in a fire. Avoid the following situations:**
  - **Connecting and disconnecting the power cord frequently**
  - **Tripping over the power cord**
  - **Bending the power cord near the connection part, and applying continuous stress to the power outlet or the connection part**
  - **Applying excessive force on the power plug**



## Provide Adequate Installation Space

- Provide enough space on each side of the machine for unrestricted operation.

View from Above  
(When the optional Inner Finisher-B1 is attached)

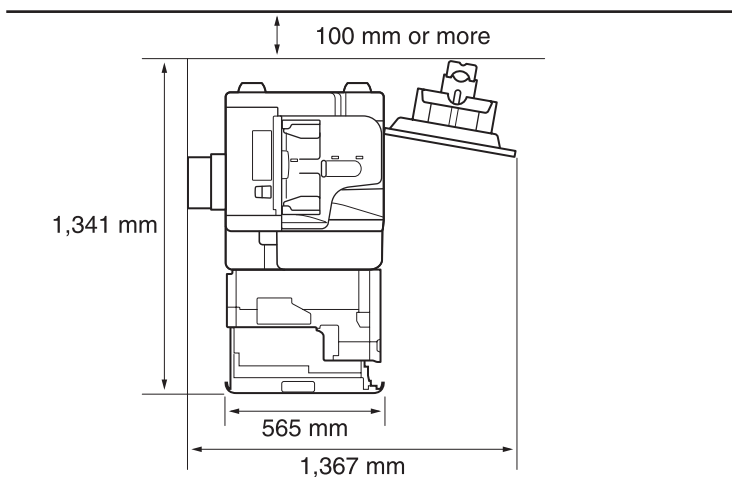

\* The width is 1,079 mm when no options are attached.

## Moving the Machine

- If you intend to move the machine, even to a location on the same floor of your building, contact your local authorized Canon dealer beforehand. Do not attempt to move the machine yourself.

## Handling Precautions

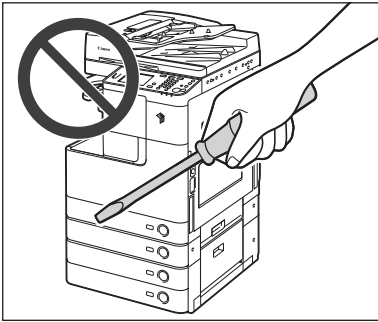

- Do not attempt to disassemble or modify the machine.

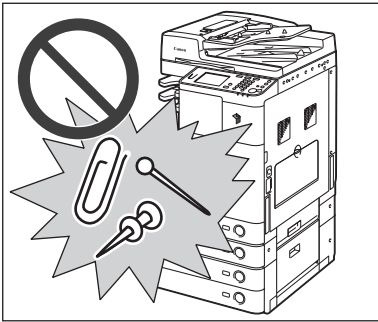

- Be careful not to spill liquids or drop any foreign objects, such as paper clips or staples inside the machine. If a foreign object comes into contact with electrical parts inside the machine, it may cause a short circuit and result in a fire or electrical shock.

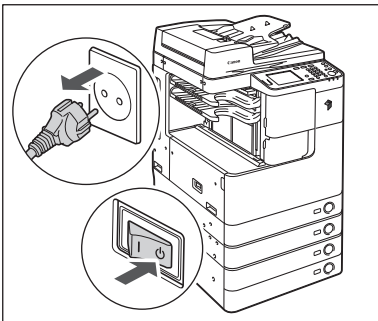

- If there is smoke or unusual noise, immediately turn the main power switch OFF, disconnect the power cord from the power outlet, and then contact your local authorized Canon dealer. Using the machine in this state may cause a fire or electrical shock. Also, avoid placing objects around the power plug so that the machine can be disconnected whenever necessary.

- Do not turn the main power switch OFF or open the front covers while the machine is in operation. This may result in paper jams.
- Some parts inside the machine are subject to high-voltages and temperatures. Take adequate precautions when inspecting the inside of the machine. Do not carry out any inspections not described in the manuals.

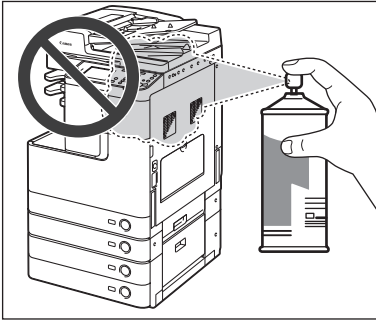

- Do not use flammable sprays, such as spray glue near the machine. There is a danger of ignition.

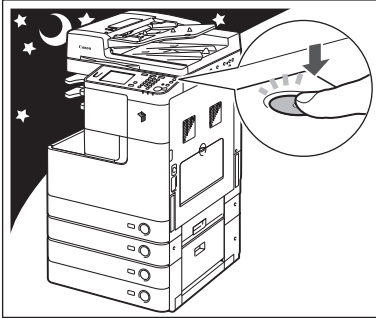

- For safety reasons, turn OFF the control panel power switch of the machine when it will not be used for a long period of time, such as overnight. As an added safety measure, turn OFF the main power switch, and disconnect the power cord when the machine will not be used for an extended period of time, such as during consecutive holidays.

- This machine generates a slight amount of ozone or other odors during normal use. Although sensitivity to ozone or other odors may vary, this amount is not harmful. Ozone or other odors may be more noticeable during extended use or long production runs, especially in poorly ventilated rooms. It is recommended that the room be appropriately ventilated, sufficient to maintain a comfortable working environment, in areas of machine operation.
- Use a modular cable shorter than three meters.
- Use a USB cable shorter than three meters.

# Cable Connection

This section describes how to connect the machine to a computer or network.

If you want to use the machine as a local printer, you can connect the machine directly to a computer with a USB cable. If the machine is shared by a group of network users, a 10BASE-T/100BASE-TX LAN cable is required.

 **IMPORTANT**

A USB cable or a network cable is not included in this package. Please obtain a suitable cable for your computer or network.

## Using the Machine as a Local Printer (USB Connection)

If you want to use the machine as a local printer, you can connect the machine and a computer using a USB cable. The machine is USB 2.0 high-speed\* compatible.

After establishing the connection between the machine and the computer, you must install the drivers and utilities that match the operating system on your computer. For more information on installing the driver through USB connection, see the *Printer Driver Installation Guide* or *Mac Printer Driver Installation Guide*. For more information on the utility software, see Chapter 3, “Accompanying CD-ROMs.”

\* This depends on the specifications of the operating system on your computer.

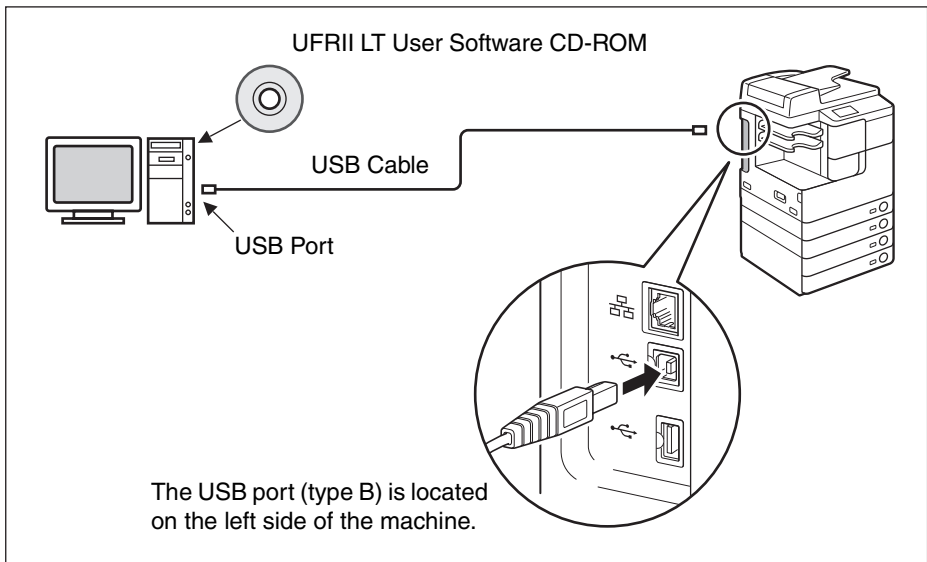

The USB port (type B) is located on the left side of the machine.

 **CAUTION**

- Before you connect the USB cable to the machine while the main power switch is ON, make sure that the ground line is connected. If the ground line is not connected, connecting the USB cable to the machine while the main power switch is ON may result in electric shock.
- If you connect or disconnect the USB cable while the main power switch is ON, do not touch the metal parts around the connector. Doing so may result in electric shock.

 **IMPORTANT**

- To prevent your machine or computer from operating poorly, do not connect or disconnect the USB cable in the following situations:
  - The drivers are being installed.
  - The computer is booting up.
  - The machine is printing.
- If you disconnect the USB cable from the machine or computer that is turned ON, always wait at least 10 seconds before reconnecting the cable. Immediately reconnecting the cable may cause your machine or computer to operate poorly.
- Make sure that the Use USB Device setting is enabled. (See Chapter 7, “Other System Settings,” in the *System Settings Guide*.)
- With the USB connection, you cannot use the Remote UI or the Remote Scan function. Some utilities are also not functional if the machine is connected to a computer via the USB cable.

 **NOTE**

The appropriate USB interface for Windows 2000/XP/Vista/7/Server 2003/Server 2008 is USB 2.0 Hi-Speed/USB Full-Speed (USB 1.1 equivalent). For Mac OS X 10.3.2 or earlier is USB Full-Speed (USB 1.1 equivalent) and Mac OS X 10.3.3 or later is USB 2.0 Hi-Speed/USB Full-Speed (USB 1.1 equivalent). For more information, consult your local authorized Canon dealer.

## Sharing the Machine with Other Network Users

The machine supports TCP/IP, which enables it to be shared by multiple network users. The machine supports both 10BASE-T and 100BASE-TX connections that can be used in most LANs.

### *Using Ethernet*

Connect the machine's LAN port to a hub port using the following types of cable:

- When connecting to a computer with a 10BASE-T port: a Category 3 (or higher) twisted pair LAN cable
- When connecting to a computer with a 100BASE-TX port: a Category 5 (or higher) twisted pair LAN cable

## CAUTION

When connecting the interface cable or network cable, be sure to observe the following precautions in order to avoid electrical shock:

- Turn OFF the main power switch before disconnecting the power cord from the power outlet. (See “Turning OFF the Main Power,” on p. 2-4.)
- Turn OFF the computer and disconnect the power cord from the power outlet.

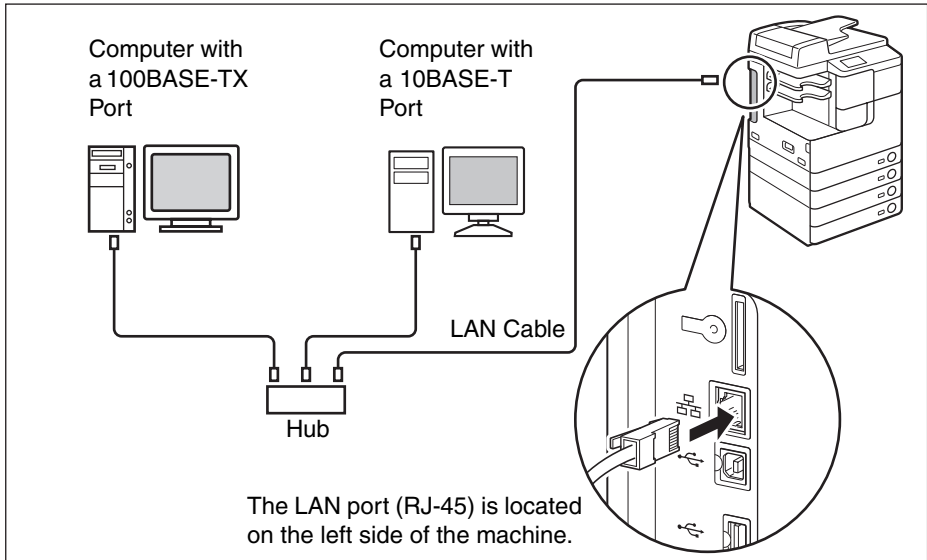

## IMPORTANT

You cannot use the machine as a repeater, bridge, or gateway.

## NOTE

- The machine can automatically detect the Ethernet speed (10BASE-T or 100BASE-TX).
- In a mixed 10BASE-T/100BASE-TX environment, devices on the network (hubs, routers, etc.) must support the mixed environment. For more information, contact your local authorized Canon dealer.

# Using the Machine as a Fax Device

With the optional Super G3 Fax Board-AG1 attached, the machine can be used as a traditional fax machine. Connect a modular cable to the machine as shown below. For more information on the telephone line, contact your local telephone company.

1

Machine Installation

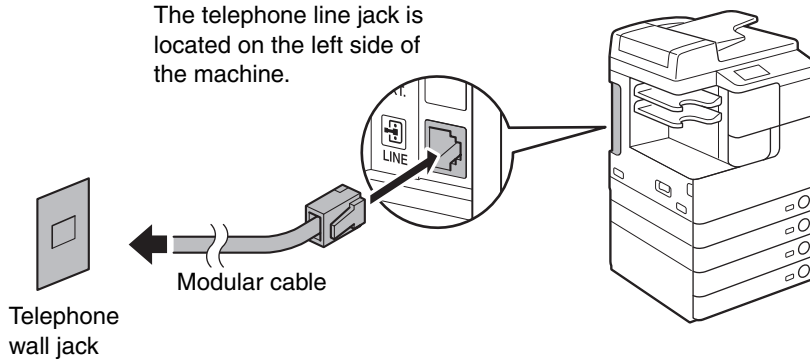

## IMPORTANT

Before using the fax function, you must set the machine configuration. For more information, see Chapter 1, “Introduction to Send and Fax Functions,” in the *Sending and Facsimile Guide*.

# Before You Start Using the Machine

# 2

## CHAPTER

This chapter describes how to turn ON/OFF the machine, describes the setup procedures, and guides you to the appropriate manuals for the required setup instructions.

---

Turning ON/OFF the Machine. . . . .	2-2
Turning ON the Main Power . . . . .	2-2
Using the Control Panel Power Switch (Sleep Mode) . . . . .	2-4
Turning OFF the Main Power . . . . .	2-4
Setup Flow . . . . .	2-5



# Turning ON/OFF the Machine

The machine has two power switches: the main power switch and the control panel power switch. When the main power switch is turned ON, the control panel power switch is also turned ON. If you turn OFF the control panel power switch, the machine enters the Sleep mode. If you want to shut down the machine, turn OFF the main power.

## Turning ON the Main Power

This section explains how to turn ON the main power.



### NOTE

For instructions on how to turn OFF the main power, see “Turning OFF the Main Power,” on p. 2-4.

- 1 Make sure that the power plug is firmly inserted into the power outlet.**



### WARNING

**Do not connect or disconnect the power cord with wet hands, as this may result in electrical shock.**

**2**

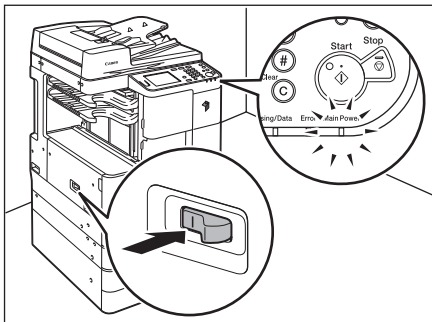

**Press the main power switch (located on the left side of the machine) to the “I” side.**

The main power indicator on the control panel lights up when the main power is turned ON.



### IMPORTANT

- If the main power indicator does not light up, make sure that the power cord is properly inserted into the machine’s socket.
- If the optional Cassette Heater Unit-37 is attached, it will enter the Standby mode when you turn ON the machine’s main power. For more information on the Cassette Heater Unit-37, contact your local authorized Canon dealer.

3

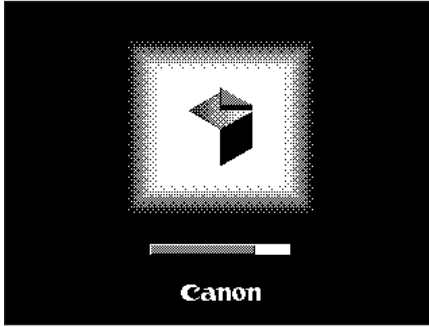

**Wait until the machine is ready to scan.**

The screen on the left is displayed until the machine is ready to scan.

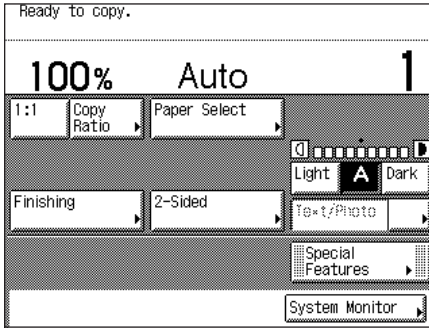

The screen on the left is displayed when the machine is ready to scan.

**NOTE**

- If the machine is managed with department IDs or user IDs, the log-in screen appears. In this case, enter your department ID or user ID (and password). (See Chapter 2, “Basic Operations,” in the *Reference Guide*.)
- You can select the top screen of the desired function that appears when the machine is turned ON. (See Chapter 3, “Configuring the Machine’s Basic Settings,” in the *Reference Guide*.)

2

Before You Start Using the Machine

## Using the Control Panel Power Switch (Sleep Mode)

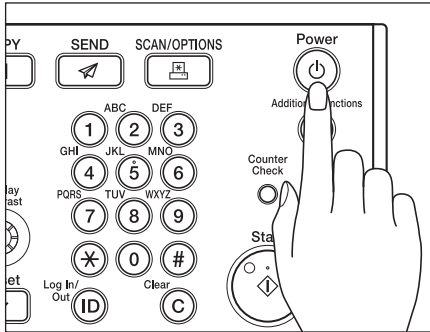

To turn the control panel ON or OFF, press the control panel power switch. When the control panel is turned OFF, the machine is in the Sleep mode.

**NOTE**

- The machine will not enter the Sleep mode when it is in operation.
- The machine can receive, forward, or print documents when it is in the Sleep mode.

Control Panel Power Switch	Machine Status
ON	Ready
OFF	Sleep mode

## Turning OFF the Main Power

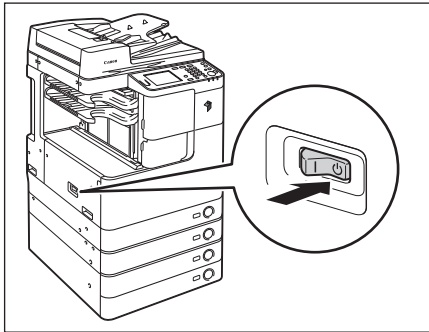

To safely turn OFF the machine's main power, press the main power switch (located on the left side of the machine) to the "⏻" side.

The main power indicator on the control panel is turned OFF.

**WARNING**

**Do not unplug the power cord before turning OFF the main power. Doing so may result in electrical shock, damage the machine, or destroy the stored data.**

**IMPORTANT**

If you need to turn ON the machine immediately after it is turned OFF (such as when restarting the machine), wait at least 10 seconds before turning it ON again. (See "Restarting the Machine," on p. 6-12.)

# Setup Flow

The machine is equipped with a wide variety of functions, some of which may require optional equipment or specific setups to become fully functional. Use the following table to figure out which setup procedures are required before using the desired functions.



## IMPORTANT

The manuals mentioned in this section are included on the User Manual CD-ROM. (See “User Manual CD-ROM,” on p. 3-2.)



## NOTE

For available functions on a product basis, see “Available Features,” on p. xii.

✓: Required

No.	Setup Items	Function							
		Send E-Mail /I-Fax	Send to File Server	Fax	Fax (from a client Computer)	Print	Remote Scan	Remote UI	Others*
1	Cable Connection (USB/Ethernet/Telephone)	✓	✓	✓	✓	✓	✓	✓	
2	License Registration (Activation)	✓	✓			✓ (PCL/PS only)			✓
3	TCP/IP Network Settings	✓	✓		✓	✓	✓	✓	
4	E-mail/I-Fax Settings	✓							
5	Fax Settings			✓	✓				
6	Software Installation				✓	✓	✓		
7	File Server Setup		✓						

\* Other functions include Send to USB memory media, Searchable PDF, and Barcode Printing.

## 1 Cable Connection (See “Cable Connection,” on p. 1-9.)

Connect the machine to your computer or network using the USB or Ethernet cable. If the Fax function is available, connect the telephone cable to the machine and the wall jack.

## 2 License Registration (Activation) (See the *System Settings Guide*.)

Activate the functions that require license registration by performing the following:

- Obtain a license key from the Canon Web site.
- Enter the license key via the touch panel display to activate the function.

## 3 TCP/IP Network Settings (See the *System Settings Guide*.)

Specify the machine's network address and establish a connection to a computer on your network. After successfully connecting the machine to the network, configure the machine for the network environment.

## 4 E-mail/I-Fax Settings (See the *System Settings Guide*.)

E-mails/I-faxes are sent/received through the SMTP server. E-mails/I-faxes can also be received through a POP3 server. After activating the Send function (optional for the imageRUNNER 2545/2535/2530/2525/2520), specify the following:

- The machine's e-mail address
- The SMTP server
- The POP3 server

## 5 Fax Settings (See the *Sending and Facsimile Guide*.)

Before sending/receiving faxes, you must specify the following:

- Unit telephone number (the machine's fax number)
- Telephone line type
- Unit name

## 6 Software Installation (See Chapter 3, “Accompanying CD-ROMs.”)

To print, fax, or scan documents from your computer, you must install the following drivers or utility software:

- Print: UFR II LT, PCL (optional), or PS (optional) printer driver (See the *Windows Printer Driver Guide* or the *Mac Printer Driver Guide*.)
- Fax: Fax driver (See the *Windows Fax Driver Guide*.)
- Remote Scan: Color Network ScanGear (See the *Network ScanGear Guide*.)

## 7 File Server Setup (See the *System Settings Guide*.)

Before sending your data to a computer on the network, you must set up the computer as a file server. You can send data over a TCP/IP network to any of the following:

- FTP servers
- Shared folders (Windows 2000/XP/Vista/7/Server 2003/Server 2008)
- Shared folders (Samba)

# Accompanying CD-ROMs

# 3

## CHAPTER

This chapter describes the CD-ROMs that come with the machine.

---

<b>User Manual CD-ROM</b> .....	<b>3-2</b>
System Requirements .....	3-2
Using the CD-ROM Menu .....	3-3
<b>UFR II LT User Software</b> .....	<b>3-4</b>
Contents of CD-ROM .....	3-4
System Requirements .....	3-5
Installation .....	3-7
<b>PCL User Software (Optional)</b> .....	<b>3-9</b>
Contents of CD-ROM .....	3-9
System Requirements .....	3-10
Installation .....	3-10
<b>PS User Software (Optional)</b> .....	<b>3-11</b>
Contents of CD-ROM .....	3-11
System Requirements .....	3-12
Installation .....	3-12
<b>Fax Driver Software (Optional)</b> .....	<b>3-14</b>
Contents of CD-ROM .....	3-14
System Requirements .....	3-15
Installation .....	3-15

# User Manual CD-ROM

The User Manual CD-ROM is software that enables you to view PDF manuals on your computer desktop. Follow the instructions below to use the User Manual CD-ROM.



## NOTE

Depending on the system configuration and product purchased, some manuals may not be needed.

3

Accompanying CD-ROMs

## System Requirements

The User Manual CD-ROM can be used in the following system environments.

	Windows	Macintosh
OS	Windows 2000 (Service Pack 4 or later) Windows XP (Service Pack 1a or later) Windows Vista (Service Pack 2 or later) Windows 7 Windows Server 2003 Windows Server 2008	Mac OS X 10.4.x or later
Memory	The memory required to run the above operating systems	
Computer	A computer that can run the above operating systems	
Display	A resolution of 1024 pixels × 768 pixels or higher	



## IMPORTANT

Depending on the configuration of your computer, some functions may not operate correctly. If the PDF manuals do not open from the CD-ROM Menu, open the PDF files directly from the [ENGLISH] folder on the User Manual CD-ROM.

## Using the CD-ROM Menu

This section describes how to use the CD-ROM Menu. The CD-ROM Menu appears when you insert the User Manual CD-ROM into the CD-ROM drive. (The sample screen shot shown here is for Windows users.)

### NOTE

- The screen shot shown below may differ from the actual display depending on the operating system used.
- For Macintosh users, double-click the [START] icon to start the CD-ROM Menu.



#### ① BROWSE MANUAL

You can read any of the listed guides by clicking on the desired guide. After clicking on the desired guide, Adobe Reader/Adobe Acrobat Reader starts, and the PDF manual is displayed.

#### ② INSTALL

You can install the listed PDF manuals on your computer. After clicking [INSTALL], select the location where you want to save the files.

#### ③ EXIT

Click to exit the CD-ROM menu.



# UFR II LT User Software

The printer driver is software that is required in order to print from applications, such as Microsoft Word/Excel/PowerPoint, etc., on your computer. The printer driver also enables you to configure settings related to printing.



The UFR II LT printer driver and the Color Network ScanGear are installed from the UFR II LT User Software CD-ROM.

3

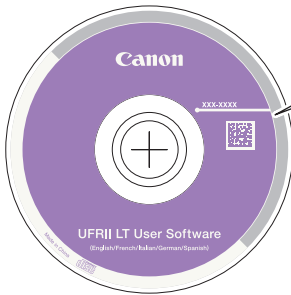

Accompanying CD-ROMs



## For Windows:

-  UFR II LT Printer Driver
-  Color Network ScanGear
-  Printer Driver Installation Guide
-  Network ScanGear Installation Guide

## For Mac:

-  Mac UFR II LT Printer Driver
-  Mac UFR II Printer Driver Installation Guide

## Contents of CD-ROM

### ■ UFR II LT Printer Driver

#### Mac UFR II LT Printer Driver

With the UFR II LT printer driver, the various data processing tasks conventionally executed within the printer are appropriately divided between the host PC and the printer to greatly reduce the overall printing time. The workload can be delegated to match the output data, thus realizing a significant increase in speed through optimization.

### ■ Color Network ScanGear

With the Color Network ScanGear, originals placed in the feeder/platen glass can be scanned and imported to a computer on the network. The Color Network ScanGear is called from a TWAIN-compliant application on your computer desktop.

Examples of applications that support TWAIN are as follows:

- Adobe Photoshop
- Adobe Acrobat
- Microsoft Word/Excel/PowerPoint etc. in Office 2000 or later

### ■ Printer Driver Installation Guide

#### Mac UFR II Printer Driver Installation Guide

Read these HTML manuals before installing the printer driver.

## ■ Network ScanGear Installation Guide

Read this HTML manual before installing the Color Network ScanGear.



### IMPORTANT

The drivers included on the CD-ROMs support 32-bit operating systems. The drivers for 64-bit operating systems can be downloaded from the Canon Web site.

## System Requirements

Before installing the software, make sure that your system meets the system requirements outlined below.

### *UFR II LT Printer Driver*

#### ■ Software

- Operating Systems:
  - Windows 2000
  - Windows XP
  - Windows Vista
  - Windows 7
  - Windows Server 2003
  - Windows Server 2008
  - Mac OS X 10.4.9 or later



#### NOTE

Supported operating systems may vary depending on the version of the printer driver used.

#### ■ Hardware

- Computer:
  - Any computer that runs the above systems
- Memory:
  - The amount of memory required to run the above systems correctly

## Color Network ScanGear

### ■ Software

- Operating Systems:
  - Windows 2000
  - Windows XP
  - Windows Vista
  - Windows 7
  - Windows Server 2003
  - Windows Server 2008
- Application Software:
  - TWAIN-compliant applications (such as Adobe Photoshop, Adobe Acrobat, Microsoft Word/Excel/PowerPoint etc. in Office 2000 or later)

### ■ Hardware

- Computer:
  - Any computer that runs the above systems
- Hard disk space:
  - The amount of disk space required to run the above systems correctly
- Memory:
  - The amount of memory required to run the above systems correctly
- A display with a resolution of at least 640 × 480 (800 × 600 or more recommended) and capable of displaying at least 256 colors.
- A network host adapter capable of TCP/IP and UDP/IP communication on an Ethernet network.

### IMPORTANT

If you want to use the machine as a network scanner, it must be connected to a computer over an IPv4 network.

### NOTE

When scanning a large number of images or images containing large amounts of image data, an insufficient memory error or significant loss of scanning speed may occur. If this happens, the following procedures should prove useful:

- Increase the amount of hard disk space by deleting or otherwise appropriately processing unnecessary files on the hard disk, etc.
- Rescan with reduced resolution.
- Increase the amount of RAM.
- Increase the amount of virtual memory to the highest possible.
- Divide originals into several sets and then scan them separately.

# Installation

From the menu screen of the CD-ROM, you can begin installing the software or display the HTML manuals to view details about the installation procedure.

For details about the installation procedure, see the *Printer Driver Installation Guide* or Mac Printer Driver Installation Guide.

## ■ CD-ROM Menu (Windows):

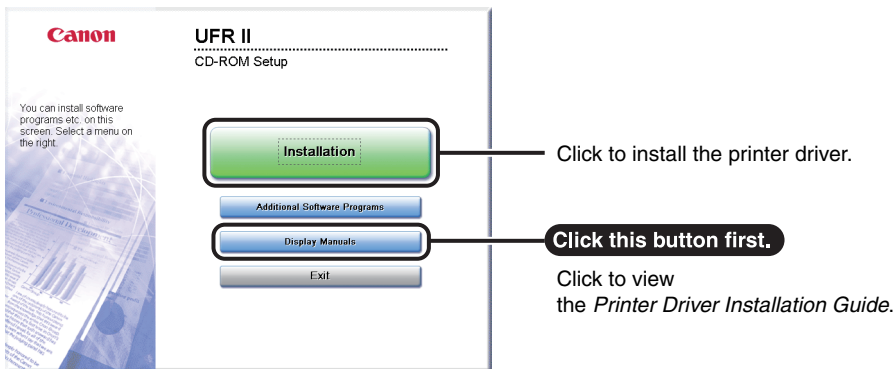

### NOTE

View the HTML manuals before you start the installation. You cannot view the HTML manuals while the installation is in progress.

### ■ Starting Installation (Macintosh):

Insert the CD-ROM into your Mac CD-ROM drive and double-click the CD icon that appears on your desktop. You can find the installer and Mac Printer Driver Installation Guide in the folder with the printer driver name.

Double-click the installer icon in the installer set folder to start the installation.

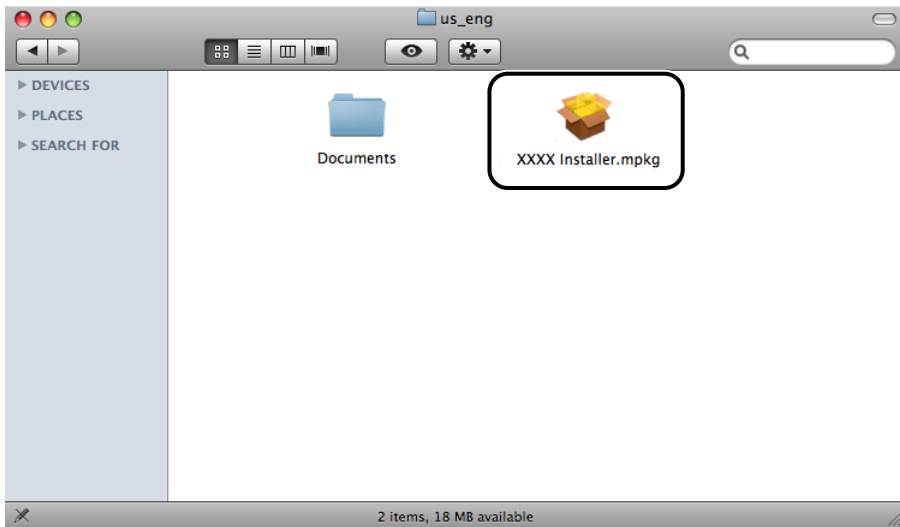

### ■ Displaying the Mac Printer Driver Installation Guide:

In the installation folder, double-click [Documents] → [Guide] → the [index.html] icon.

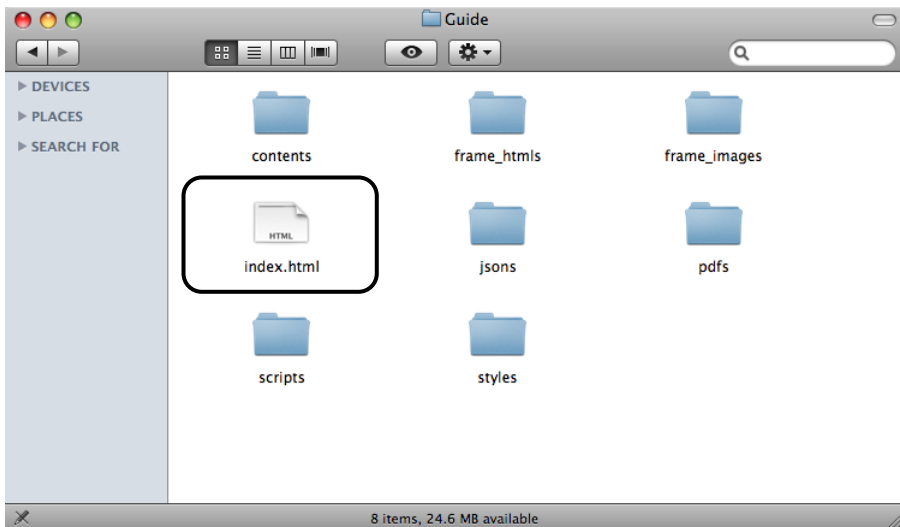

#### NOTE

Depending on the printer model you are using, the installation guide may be a PDF file. If so, double-click the PDF icon in the [Documents] folder.

# PCL User Software (Optional)

The PCL printer driver is installed from the PCL User Software CD-ROM.



## IMPORTANT

The PCL User Software CD-ROM is included with the optional PCL Printer Kit.

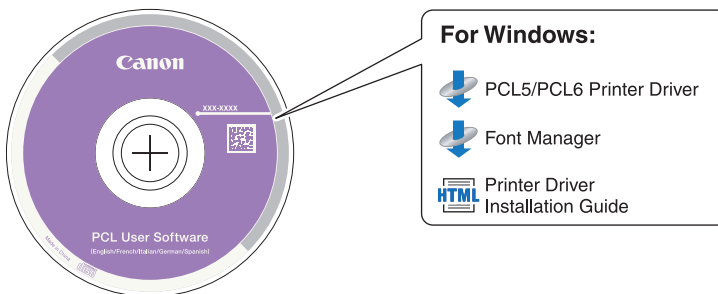

## Contents of CD-ROM

### ■ PCL Printer Driver (PCL5/PCL6)

The PCL5 and PCL6 printer drivers can be used with most kinds of business applications, and take full advantage of the host PC's processing power for performing high-speed processing. PCL6 is an advanced version of PCL5, and offers superior printing quality and speed.

### ■ Printer Driver Installation Guide

Read this HTML manual before installing the printer driver.

### ■ Font Manager

Use this software to manage fonts and view them accurately in Windows. Double-click [Canonfm] → the [Setup.exe] icon to install the software. For more information, see the Readme file located in \Canonfm\program files\Canon\Font Manager\English.



## IMPORTANT

The drivers included on the CD-ROMs support 32-bit operating systems. The drivers for 64-bit operating systems can be downloaded from the Canon Web site.

# System Requirements

Before installing the software, make sure that your system meets the system requirements outlined below.

## ■ Software

- Operating Systems:
  - Windows 2000
  - Windows XP
  - Windows Vista
  - Windows 7
  - Windows Server 2003
  - Windows Server 2008

### NOTE

Supported operating systems may vary depending on the version of the printer driver used.

## ■ Hardware

- Computer:
  - Any computer that runs the above systems
- Memory:
  - The amount of memory required to run the above systems correctly

# Installation

From the menu screen of the CD-ROM, you can begin installing the software or display the HTML manual to view details about the installation procedure.

## ■ CD-ROM Menu:

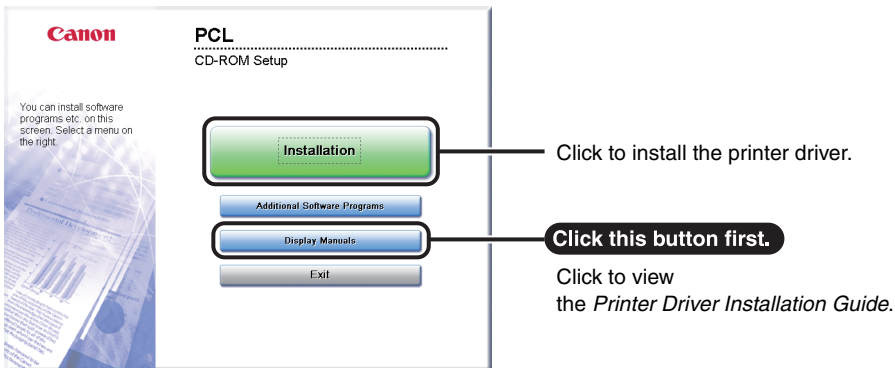

### NOTE

View the HTML manuals before you start the installation. You cannot view the HTML manuals while the installation is in progress.

# PS User Software (Optional)

The PS printer driver is installed from the PS User Software CD-ROM.



## IMPORTANT

The PS User Software CD-ROM is included with the optional PS Printer Kit.

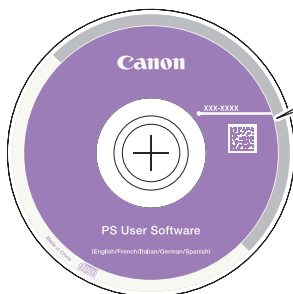

### For Windows:

 PS Printer Driver

 Printer Driver  
Installation Guide

### For Mac:

 Mac PS Printer Driver

 Mac PS Printer Driver  
Installation Guide

## Contents of CD-ROM

### ■ PS Printer Driver

#### Mac PS Printer Driver

The PS printer driver converts print data from applications into data for use with PS printers, and sends it to the printer. As well as converting print data, it can also enable you to configure settings relating to finishing and detailed settings such as halftones, and provides an appropriate print environment for desktop publishing and publishing on demand.

### ■ Printer Driver Installation Guide

#### Mac PS Printer Driver Installation Guide

Read these HTML manuals before installing the printer driver.



## IMPORTANT

The drivers included on the CD-ROMs support 32-bit operating systems. The drivers for 64-bit operating systems can be downloaded from the Canon Web site.



# System Requirements

Before installing the software, make sure that your system meets the system requirements outlined below.

## ■ Software

- Operating Systems:
  - Windows 2000
  - Windows XP
  - Windows Vista
  - Windows 7
  - Windows Server 2003
  - Windows Server 2008
  - Mac OS X 10.4.9 or later

## ■ Hardware

- Computer:
  - Any computer that runs the above systems
- Memory:
  - The amount of memory required to run the above systems correctly

# Installation

From the menu screen of the CD-ROM, you can begin installing the software or display the HTML manual to view details about the installation procedure.

For details about the installation procedure, see the *Printer Driver Installation Guide* or Mac Printer Driver Installation Guide.

## ■ CD-ROM Menu (Windows):

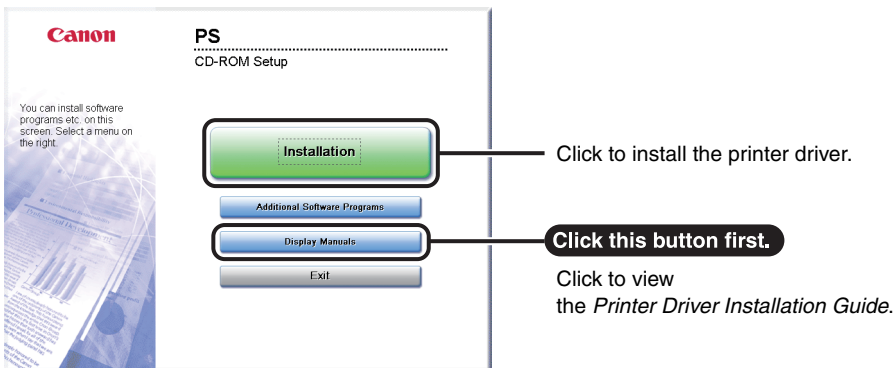

 **NOTE**

View the HTML manuals before you start the installation. You cannot view the HTML manuals while the installation is in progress.

For details about installing the printer driver and displaying the Mac Printer Driver Installation Guide, see “UFR II LT User Software,” on p. 3-4.

# Fax Driver Software (Optional)

The fax driver is software that is required in order to send faxes from applications on your computer desktop. The fax driver is installed from the Fax Driver Software CD-ROM.



## IMPORTANT

The Fax Driver Software CD-ROM is included with the optional Super G3 Fax Board-AG1.

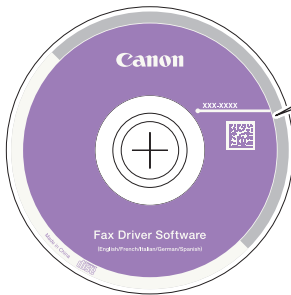

### For Windows:



Fax Driver



Fax Driver  
Installation Guide

## Contents of CD-ROM

### ■ Fax Driver

With the fax driver installed on your computer, you can fax documents directly from applications on your computer desktop, instead of scanning originals on the machine.

### ■ Fax Driver Installation Guide

Read this HTML manual before installing the fax driver.



## IMPORTANT

The drivers included on the CD-ROMs support 32-bit operating systems. The drivers for 64-bit operating systems can be downloaded from the Canon Web site.

# System Requirements

Before installing the software, make sure that your system meets the system requirements outlined below.

## ■ Software

- Operating Systems:
  - Windows 2000
  - Windows XP
  - Windows Vista
  - Windows 7
  - Windows Server 2003
  - Windows Server 2008

## ■ Hardware

- Computer:
  - Any computer that runs the above systems
- Memory:
  - The amount of memory required to run the above systems correctly

# Installation

From the menu screen of the CD-ROM, you can begin installing the software or display the HTML manual to view details about the installation procedure.

## ■ CD-ROM Menu:

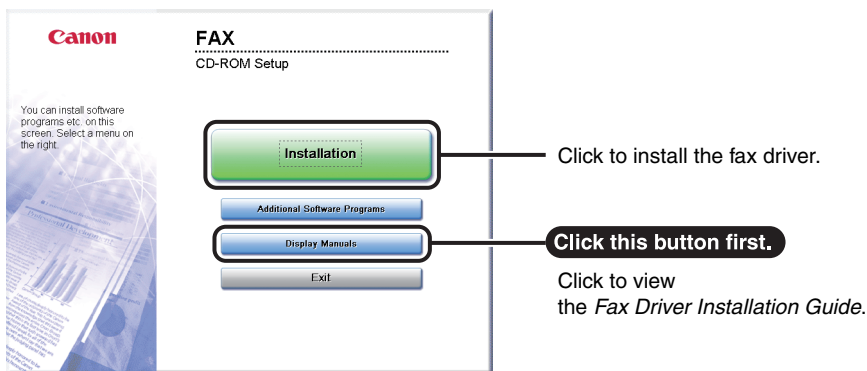

## NOTE

View the HTML manuals before you start the installation. You cannot view the HTML manuals while the installation is in progress.



# Using the Basic Functions

# 4

## CHAPTER

This chapter describes the operations of the machine's basic functions.

---

Making a Copy .....	4-2
Printing from a Computer .....	4-4
Printing from a USB Memory Media Device (Media Print) .....	4-6
Sending a Document (E-Mail, I-Fax, File Server, and USB Memory Media Device) .....	4-8
Sending a Fax .....	4-10
Scanning from a Computer (Remote Scan) .....	4-12
Operating the Machine from a Computer (Remote UI) .....	4-14

# Making a Copy

This section describes the basic operation procedure for copying originals.

## 1 Display the Copy Screen

Ready to copy.

100% Copy Ratio Auto 1

1:1 Copy Ratio Paper Select

Finishing 2-Sided

Light A Dark

Special Features

System Monitor

Press (COPY) to display the top screen of the Copy function.

- If the machine is in the Sleep mode, press (Power).

## 2 Place Your Originals

Place your originals in the feeder or on the platen glass.

- Close the feeder/platen cover after placing your originals on the platen glass.

### How to Log in to the Machine

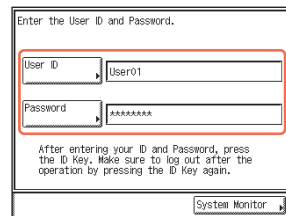
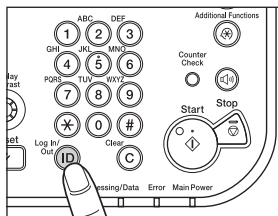
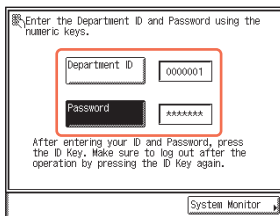

- Enter your department ID and password if the screen prompts you to do so → press (Log In/Out).
- Enter your user ID and password if the screen prompts you to do so → press (Log In/Out).
- Insert the control card if the screen prompts you to do so.
- When you have finished the operations, press (Log In/Out) or remove the control card to log out.

For more information, see Chapter 2, “Basic Operations,” in the *Reference Guide*.

### 3 Specify the Number of Copies

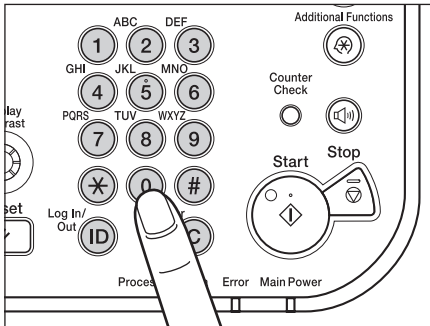

Enter the desired number of copies (1 to 999) using 0 - 9 (numeric keys).

- To change the value you have entered, press **C** (Clear) → enter the correct value.
- The number of copies you specify is displayed on the upper right side of the touch panel display.

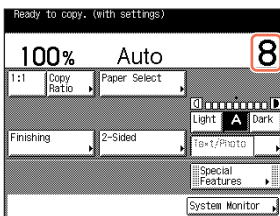

### 4 Start Copying

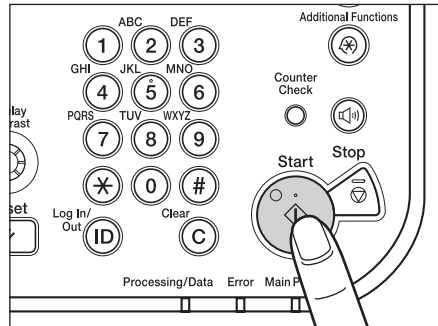

Press **Start**.

- When the screen below appears, select the original size → press **[OK]** → **Start**.

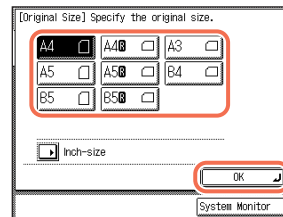

- To cancel copying, press **Stop**. You can also cancel the current copy job by pressing **[Cancel]** on the screen indicating the copy processing status.\*

\* The canceling procedure differs depending on the job status. For more information, see Chapter 1, "Introduction to Copy Function," in the *Copying Guide*.



# Printing from a Computer

This section describes the basic operation procedure for printing a document from a computer.

4

Using the Basic Functions

## 1 Open the [Print] Dialog Box

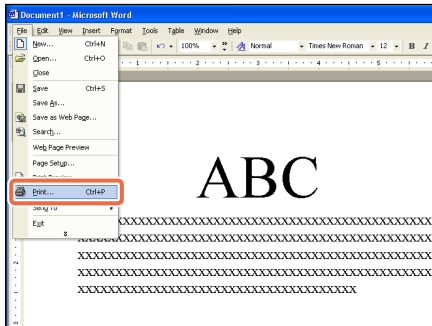

In the application you open the document to print from, click the [File] menu → select [Print].

## 2 Select the Printer

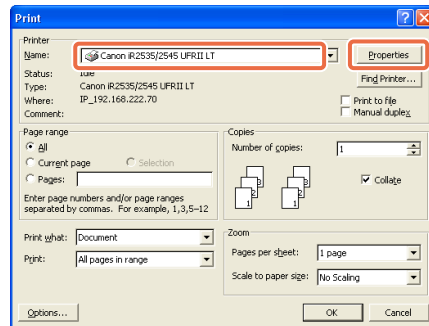

In the [Print] dialog box, select your printer → click [Properties]\*1.

- On this screen, you can specify the number of prints, and pages to print. If you need no detailed settings, click [OK]\*2 to start printing.
- \*1 The name of the button to display the printer setting sheet shown on step 3 may vary depending on the application you are using.
- \*2 The name of the button to start printing may vary depending on the application you are using.
- † The dialog boxes for print settings shown in steps 2 and 4 may vary depending on the application you are using.

## Printer Driver

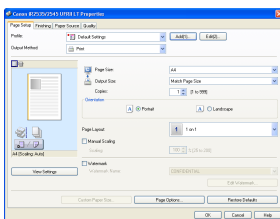

The printer driver installed on your computer enables the machine to print the documents from the applications on your computer. The printer driver also enables you to specify the various print settings such as paper size and finishing style.

For more information on the printer driver settings, see the *Windows Printer Driver Guide*, the *Mac Printer Driver Guide*, or the help on the printer driver.

†The operation procedure in this section is for a Windows computer. For instructions on how to print from a Macintosh computer, see the *Mac Printer Driver Guide*.

†The printer driver screens shown below may differ from the ones displayed on your computer, depending on the machine and optional equipment, type and version of printer driver, or operating system you are using.

### 3 Specify the Print Settings

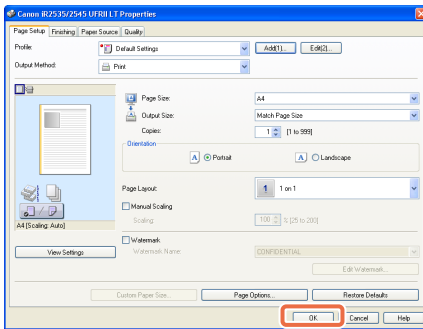

In each sheet of the printer setting dialog box, specify the print settings that suit your preferences → click [OK].

For more information on the print settings, see the *Windows Printer Driver Guide*, the *Mac Printer Driver Guide*, or the help on the printer driver.

### 4 Start Printing

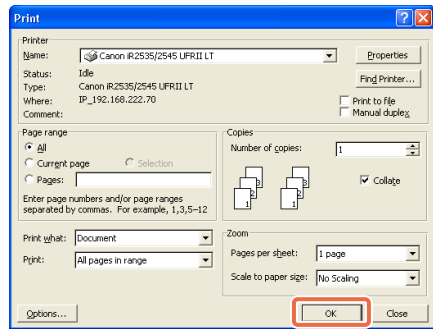

Specify the number of prints and pages to print as necessary → click [OK].\*1

- To cancel printing on your computer, click [Cancel] in the dialog box that appears when the print data is being processed.
- To cancel printing on the machine's control panel, use the System Monitor screen displayed by pressing  (Stop) or [System Monitor].\*2

\*1 The name of the button to start printing may vary depending on the application you are using.

\*2 The canceling procedure differs depending on the job status. For more information, see Chapter 3, "Managing Print Jobs," in the *Printer Guide*.

### Secure Printing

On the printer driver screen, you can select Secure Printing as the output method when printing your documents. Secure Printing enables you to hold your print jobs until the appropriate password assigned on the printer driver is entered at the machine. This way, confidential documents are not left lying on the machine's output tray.

For more information on Secure Printing, see "Printing from a Computer," in Chapter 1 of the *Printer Guide*.

# Printing from a USB Memory Media Device (Media Print)

This section describes the basic operation procedure for printing JPEG or TIFF files stored in the USB memory media device directly connected to the machine.

## 1 Prepare

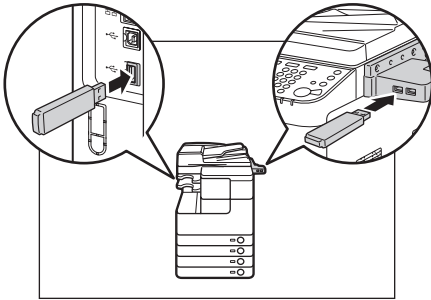

**Insert the USB memory media device containing the file you want to print into the USB port on the left or right side of the machine.\***

- When a screen indicating the USB memory media device has been inserted appears, press [Done] and proceed to the next step.
- If the machine is in the Sleep mode, press  (Power).
- Enter your ID and password or insert the control card if the screen prompts you to do so. (See “How to Log in to the Machine,” on p. 4-2.)

\* The USB ports on the right side of the machine are optional (USB Application 3-Port Interface Kit-A1). The left side USB port is not available when the above option is attached.

† Some USB memory media devices are not compatible with the machine. For more information, see Chapter 2, “Printing from USB Memory Media (Media Print),” in the *Printer Guide*.

## 2 Display the Memory Media Print Screen

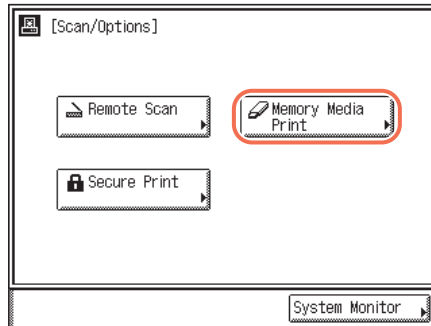

Press  (SCAN/OPTIONS) to display the Scan/Options screen → press [Memory Media Print].

†The Media Print function is available only when it is enabled by the System Settings of the machine. (See Chapter 7, “Other System Settings,” in the *System Settings Guide*.)

### 3 Select the file to print

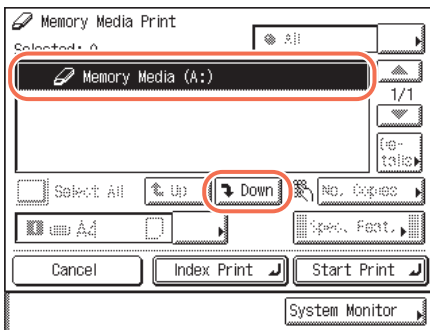

Select the USB memory media device containing the file you want to print → press [Down] to display the files in the media device.

### 4 Start Printing

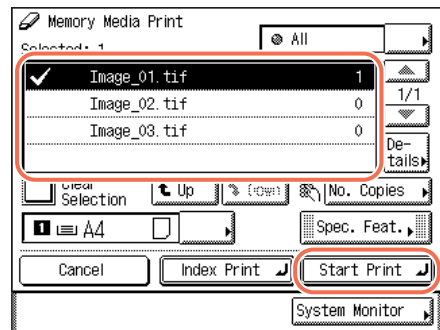

Select the files you want to print → press [Start Print].

- To select the file in a folder, select the folder → press [Down] to display the files → select the file.
- To cancel printing, press (Stop). You can also cancel the current print job by pressing [Cancel] on the screen indicating the print processing status.\*

\* The canceling procedure differs depending on the job status. For more information, Chapter 3, “Managing Print Jobs,” in the *Printer Guide*.

- When printing is complete, remove the USB memory media device from the USB port.

#### Print Setting Options

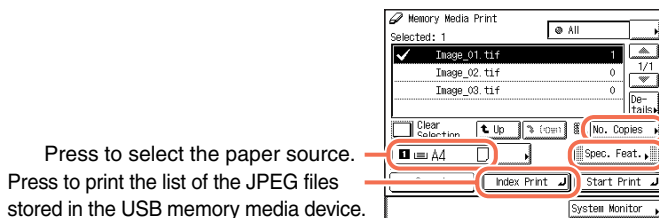

Press to select the paper source.  
Press to print the list of the JPEG files stored in the USB memory media device.

Press to specify the print quantity.  
Press to specify the optional settings for printing JPEG files.

# Sending a Document (E-Mail, I-Fax, File Server, and USB Memory Media Device)

This section describes the basic operation procedure for sending a document.

## 1 Display the Send Screen

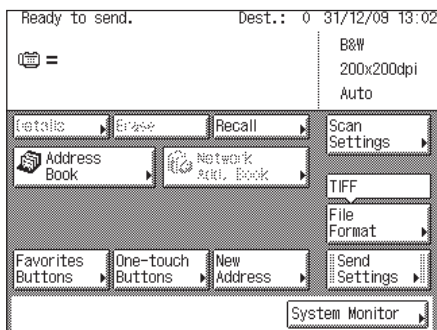

Press  (SEND) to display the top screen of the Send and Fax functions.

- If the machine is in the Sleep mode, press  (Power).
- Enter your ID and password or insert the control card if the screen prompts you to do so. (See “How to Log in to the Machine,” on p. 4-2.)
- If the screen shown below appears, enter your user name and password and specify the login destination → press [Log In].

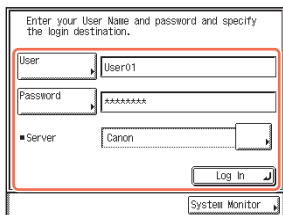

## 2 Place Your Originals

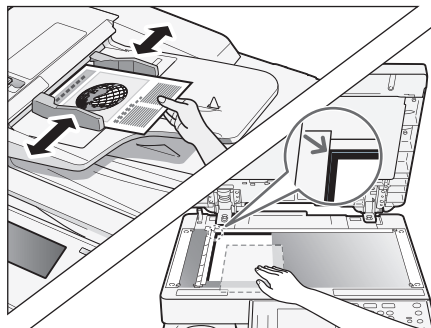

Place your originals in the feeder or on the platen glass.

- Close the feeder/platen cover after placing your originals on the platen glass.

### IMPORTANT

To use the Send function with the imageRUNNER 2545/2535/2530/2525/2520, the function must be activated with the optional Color Send Kit-Y1.

### 3 Specify the Destination

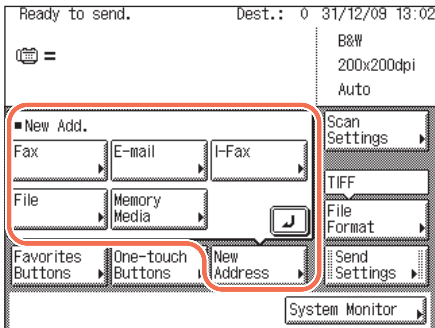

Press [New Address] → select the sending method\* → specify the destination.

- \* The available sending methods displayed on the screen may vary, depending on the settings.
- You can also specify the destination by using [Address Book], [Favorites Buttons], or [One-touch Buttons]. These functions save you the effort of entering a destination each time you send documents.

For information on specifying destinations, see Chapter 4, “Specifying Destinations Easily and Quickly,” in the *Sending and Facsimile Guide*.

† Some USB memory media devices are not compatible with the machine. For more information, see Chapter 2, “Sending Documents,” in the *Sending and Facsimile Guide*.

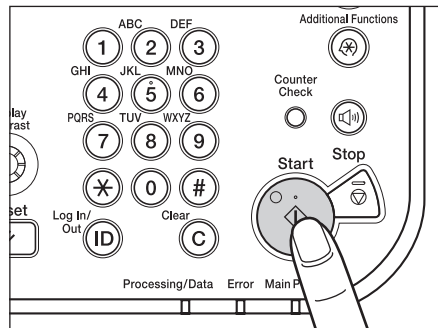

### 4 Start Sending

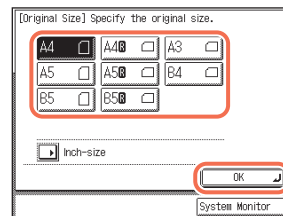

Press  (Start).

- When the screen below appears, select the original size → press [OK].



- Enter your user name and password → press [OK], if the machine prompts you to do so when you press  (Start).
- To cancel scanning originals, press  (Stop). You can also cancel scanning originals by pressing [Cancel] on the screen indicating the send processing status.

For instructions on how to cancel sending a document during transmission, see Chapter 2, “Sending Documents,” in the *Sending and Facsimile Guide*.

# Sending a Fax

This section describes the basic operation procedure for sending a fax.

## 1 Display the Send Screen

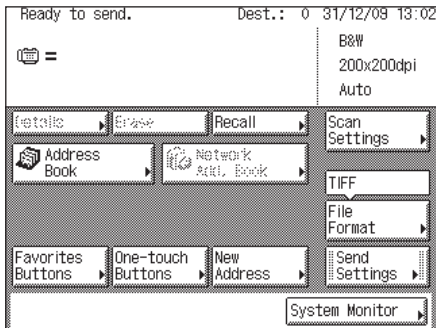

Press  (SEND) to display the top screen of the Send and Fax functions.

- If the machine is in the Sleep mode, press  (Power).
- Enter your ID and password or insert the control card if the screen prompts you to do so. (See “How to Log in to the Machine,” on p. 4-2.)
- If the screen shown below appears, enter your user name and password and specify the login destination → press [Log In].

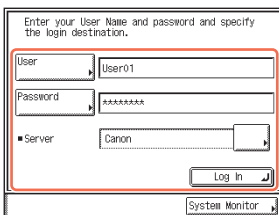

## 2 Place Your Originals

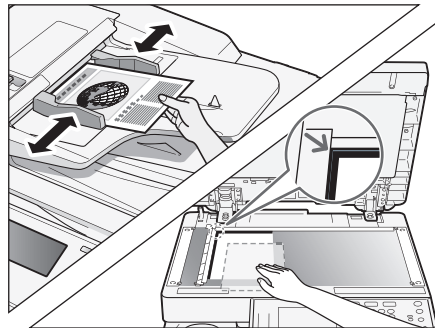

Place your originals in the feeder or on the platen glass.

- Close the feeder/platen cover after placing your originals on the platen glass.



### IMPORTANT

- The Fax function is available only when the optional Super G3 Fax Board-AG1 is attached to the machine.
- Even when the above option is attached, using the Fax function can be restricted by the settings of Authorized Send. (See Chapter 4, “Customizing Settings,” in the *Remote UI Guide*.)

### 3 Enter the Fax Number

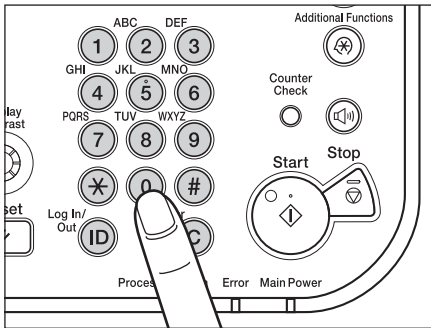

Enter the fax number using 0 - 9 (numeric keys).

- You can also specify the destination by using [Address Book], [Favorites Buttons], or [One-touch Buttons]. These functions save you the effort of entering a fax number each time you send documents.

For information on specifying destinations, see Chapter 4, “Specifying Destinations Easily and Quickly,” in the *Sending and Facsimile Guide*.

### 4 Start Sending

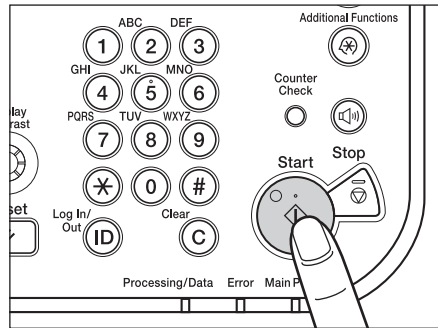

Press  (Start).

- When the screen below appears, select the original size → press [OK].

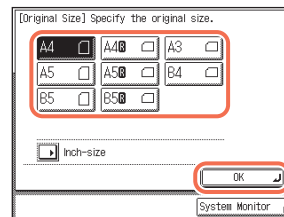

- To cancel scanning originals, press  (Stop). You can also cancel scanning originals by pressing [Cancel] on the screen indicating the fax processing status.

For instructions on how to cancel sending a document during transmission, see Chapter 2, “Sending Documents,” in the *Sending and Facsimile Guide*.





# Scanning from a Computer (Remote Scan)

This section describes the basic operation procedure for scanning originals to load the scanned images to a computer.

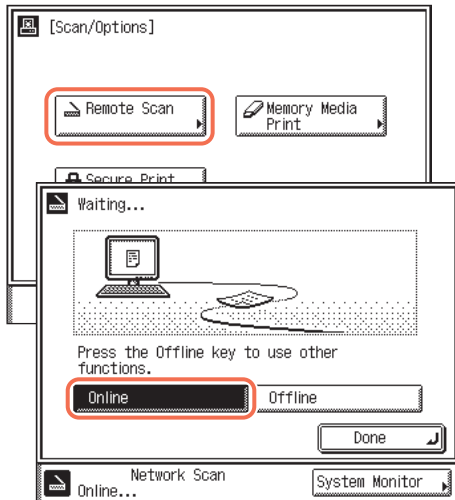
## 1 Switch the Machine Online



Press  (SCAN/OPTIONS) to display the Scan/Options screen → press [Remote Scan] → [Online].

- If the machine is in the Sleep mode, press  (Power).
- Enter your ID and password or insert the control card if the screen prompts you to do so. (See “How to Log in to the Machine,” on p. 4-2.)

## 2 Place Your Originals

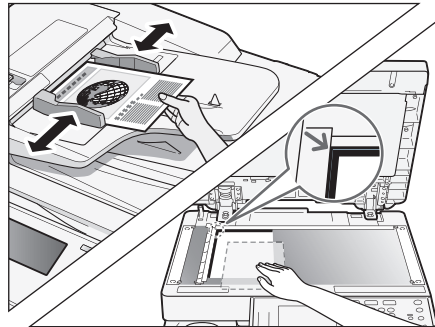

Place your originals in the feeder or on the platen glass.

- Close the feeder/platen cover after placing your originals on the platen glass.

### IMPORTANT

- If you want to use the machine as a network scanner, it must be connected to a computer over an IPv4 network.
- The screen shots shown in this section may differ from the ones displayed on your computer, depending on the application or operating system you are using.

### 3 Open the Color Network ScanGear

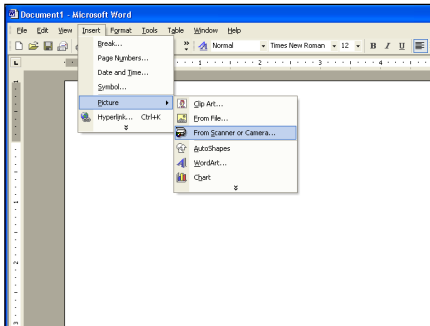

From the menu of the application, select the command\* to start the scanning operation.

\* Command names include [Scan New], [Acquire], and others, depending on the application you are using.

- Make sure that the Color Network ScanGear is selected as the scanner to be used.

For more information, see the documentation that comes with your TWAIN-compliant application.

### 4 Start Scanning

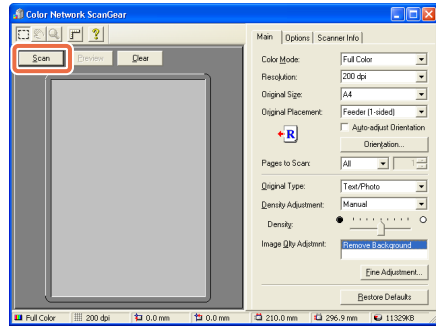

Specify the scan settings that suit your preferences → click [Scan].

- On the Color Network ScanGear dialog box, specify the settings such as the color mode and resolution.
- To cancel scanning, click [Cancel] in the dialog box that appears when the scan data is being processed.
- When scanning is complete, switch the machine offline.

For instructions on how to specify the settings on the Color Network ScanGear dialog box, see the *Network ScanGear Guide* or the help on the Color Network ScanGear.

# Operating the Machine from a Computer (Remote UI)

This section describes the basic operation procedure for accessing the machine from a computer by using the Remote UI.

4

Using the Basic Functions

## 1 Start Your Web Browser

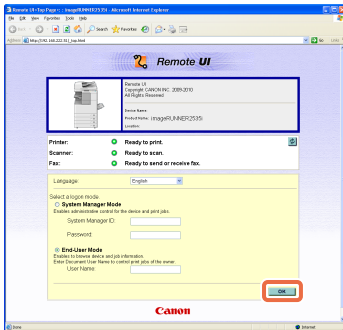

Start your web browser → enter the IP address\* of the machine into the Web browser on your computer to access the Remote UI → press [ENTER] key on your computer keyboard.

\* The IP address in the screen shots in this section is for illustrative purposes only. Ask your network administrator for the IP address of your machine.

## 2 Log in to the Remote UI

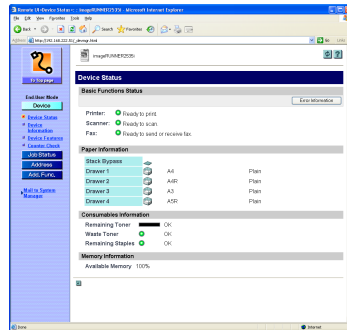

On the Remote UI top page displayed in step 1, enter your department ID or user ID and password\* → click [OK].

• After successfully logging in, the Device Status page is displayed. Go to other pages as necessary by using the menu on the left side of the page.

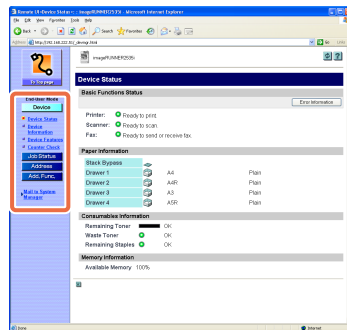

\* The ID and password you have to enter when logging in depend on the Remote UI setting. Ask your system administrator for your ID and password.

# Routine Maintenance

# 5

## CHAPTER

This chapter describes how to load paper, replace the toner, and clean the machine and introduces some of the consumables such as toner, stamp ink, and staple cartridges.

---

<b>Paper Drawers</b> .....	5-2
Loading Paper .....	5-3
Adjusting a Paper Drawer to Hold a Different Paper Size .....	5-5
<b>Replacing the Toner</b> .....	5-8
<b>Routine Cleaning</b> .....	5-13
Platen Glass and Cover .....	5-13
Feeder Scanning Area and Rollers .....	5-14
<b>Consumables</b> .....	5-18
Paper Stock .....	5-18
Toner .....	5-19
Stamp Ink Cartridge .....	5-20
Staple Cartridge .....	5-20

# Paper Drawers

This section describes how to load paper in the paper drawers.

When any of the paper drawers are empty, a message prompting you to load paper may appear on the touch panel display, indicating which paper drawer needs additional paper supply. To clear the message, load paper as described below.

## CAUTION

Take care not to cut your hands on the edges of the paper when loading it into the machine.

## IMPORTANT

- The paper sizes/types that can be loaded in the paper drawers are as follows:
  - Size: A4, A4R, A3, A5R, B4, B5, and B5R
  - Type: Plain, Recycled, Color, and 3-hole punch  
(See “Available Paper Stock,” on p. 7-2.)
- With the optional Envelope Feeder Attachment-D1, the following envelopes can be loaded in the Paper Drawer 2: No.10 (COM10), ISO-B5, Monarch, ISO-C5, and DL.  
(See Chapter 4, “Optional Equipment,” in the *Reference Guide*.)
- The number of available paper drawers may vary depending on the machine configuration. (See “Available Features,” on p. xii.)

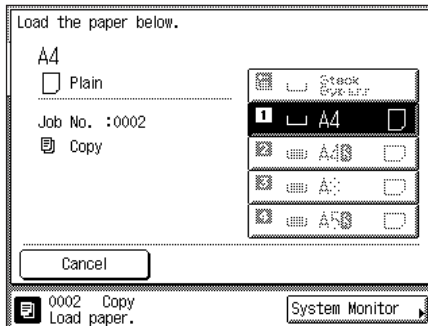

## NOTE

- If paper runs out while printing is in progress, the screen on the left appears. The remaining prints are automatically completed as soon as you load the correct paper.
- The screen on the left appears also when the paper drawers are not fully inserted in the machine.

# Loading Paper

Load paper in the paper drawers as described below.



## IMPORTANT

- Do not load nonstandard-sized paper in the paper drawers.
- Do not load the following types of paper in the paper drawers, as they may cause paper jams:
  - Severely curled or wrinkled paper
  - Lightweight straw paper (less than approximately 64 g/m<sup>2</sup>)
  - Transparencies
  - Labels
  - Paper on which color images have been copied (Do not print on the reverse side of such paper.)
  - Paper which has been printed on using a thermal transfer printer (Do not print on the reverse side of such paper.)
- Fan the stack of paper well before loading it, and align the edges of the paper stack on a flat surface.
- Never place paper or anything in the empty part of the drawer next to the paper stack. Doing so may cause paper jams.

1

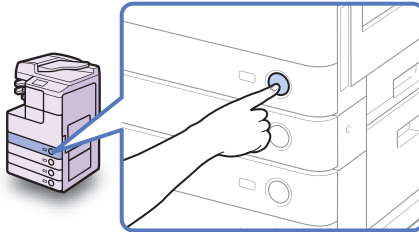

**Press the button on the paper drawer in which you want to load paper.**

2

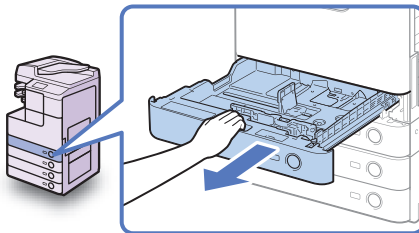

**Grip the handle and pull out the paper drawer until it stops.**

3

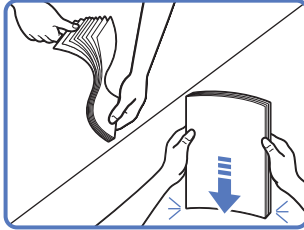
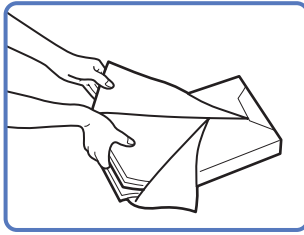

**Open a package of paper and take out the paper stack from the package.**

**CAUTION**

Take care not to cut your hands on the edges of the paper when loading it into the machine.

**IMPORTANT**

Rewrap any remaining paper in its original package, and store it in a dry place, away from direct sunlight.

**NOTE**

- For high-quality printouts, use paper recommended by Canon.
- Before loading paper, always fan the sheets several times, and align the edges to facilitate feeding.

4

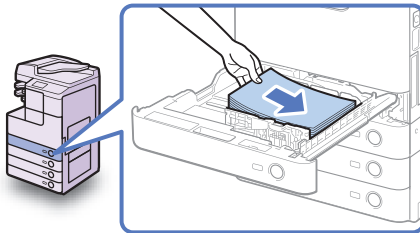

**Load the paper stack into the paper drawer.**

Even out the edges of the paper stack, and load the paper stack against the right wall of the paper drawer.

**CAUTION**

Take care not to cut your hands on the edges of the paper when loading it into the machine.

**IMPORTANT**

- Rolled or curled paper must be straightened out prior to use.
- Make sure that the height of the paper stack does not exceed the loading limit marks (▽▽▽) both on the left and back sides of the slide guides.
- Make sure that the paper size/type setting of the paper drawer matches the size/type of the paper that is being loaded.

**NOTE**

- Each paper drawer holds about 550 sheets of paper (80 g/m<sup>2</sup>) except that Drawer 1 of the imageRUNNER 2530/2525/2520i/2520 holds 250 sheets of paper (80 g/m<sup>2</sup>).
- If there are instructions on the package of paper about which side of the paper to load facing up, follow those instructions.
- When printing one-sided documents on paper loaded in the paper drawer, the side facing up is the one printed on.

- If problems occur, such as poor print quality or paper jams, try turning the paper stack over and reloading it.
- For more information on the print direction of preprinted paper (paper which has logos or patterns already printed on it), see Chapter 7, “Appendix,” in the *Reference Guide*.

5

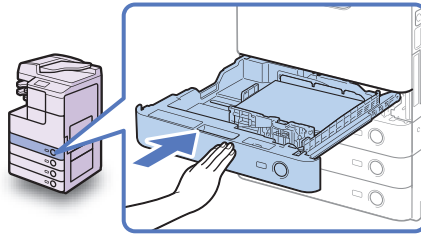

**Gently push the paper drawer back into the machine until it clicks into place.**

**CAUTION**

When returning the paper drawer to its original position, be careful not to get your fingers caught, as this may result in personal injury.



**IMPORTANT**

Make sure that the paper drawer is fully inserted. You will not be able to make prints if the paper drawer is not completely pushed into the machine.



**NOTE**

If there are remaining prints to be completed, the machine automatically resumes printing as soon as you load the correct paper.

6

**Specify the paper type as required.**

For help, see Chapter 3, “Configuring the Machine’s Basic Settings,” in the *Reference Guide*.



**IMPORTANT**

Make sure that the paper type setting of the paper drawer matches the type of the paper that is being loaded.

## Adjusting a Paper Drawer to Hold a Different Paper Size

If you want to change the size of paper in the paper drawer, adjust the slide guides for the new paper size as described below.

1

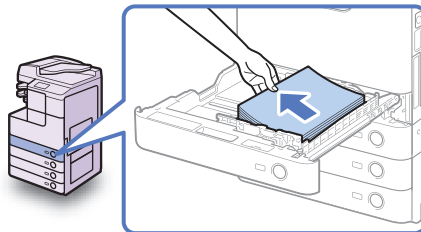

**Open the paper drawer and remove all the loaded paper.**

For instructions on how to open the paper drawer, see steps 1 and 2 in “Loading Paper,” on p. 5-3.



- 2** Squeeze the lever on the side guide. Without releasing the lever, slide the side guide leftward or rightward to align it with the mark for the desired paper size.

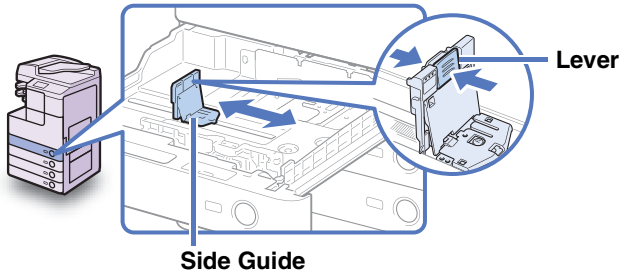

- 3** Squeeze the lever on the front guide. Without releasing the lever, slide the front guide backward or forward to align it with the mark for the desired paper size.

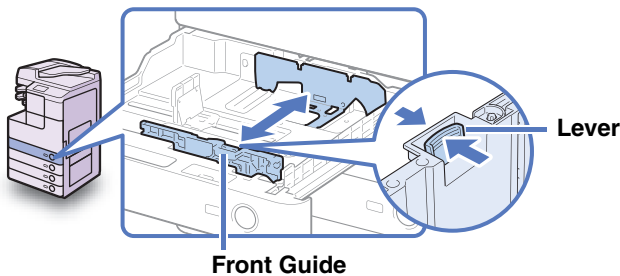

**IMPORTANT**

Adjust the guides correctly. Failure to do so may cause paper jams or dirty prints, or make the inside of the machine dirty.

**4**

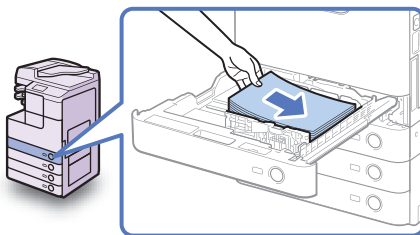

**Load the appropriate size of paper into the paper drawer.**

**CAUTION**

Take care not to cut your hands on the edges of the paper when loading it into the machine.

**IMPORTANT**

- Rolled or curled paper must be straightened out prior to use.
- Make sure that the height of the paper stack does not exceed the loading limit marks (▽▽▽) both on the left and back sides of the slide guides.
- Make sure that the paper size setting of the paper drawer matches the size of the paper that is being loaded.

## 5 Change the paper size plates to indicate the correct paper size on the paper drawer.

Paper Drawer's Capacity: 550 sheets

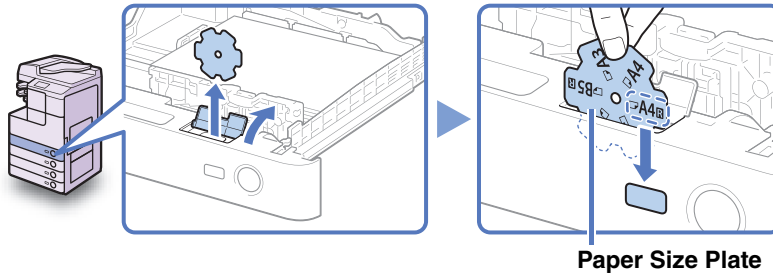

Paper Drawer's Capacity: 250 sheets

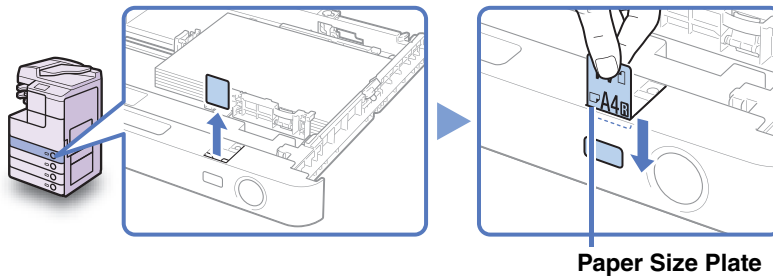

### IMPORTANT

The paper sizes marked on the plates may include sizes that the machine is unable to use.

## 6

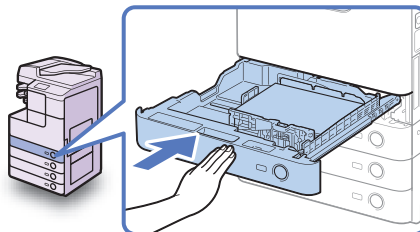

**Gently push the paper drawer back into the machine until it clicks into place.**

### CAUTION

**When returning the paper drawer to its original position, be careful not to get your fingers caught, as this may result in personal injury.**

## 7 Specify the paper type as required.

For help, see Chapter 3, "Configuring the Machine's Basic Settings," in the *Reference Guide*.

### IMPORTANT

Make sure that the paper type setting of the paper drawer matches the type of the paper that is being loaded.

# Replacing the Toner

When only a small amount of toner is left inside the machine, the message <Prepare the toner.> is displayed on the screen. Although you may continue printing, it is highly recommended that you prepare to install a new toner cartridge before the toner completely runs out.

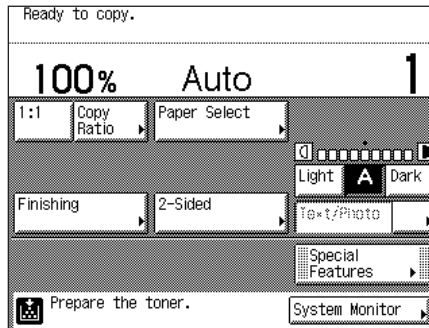

When toner runs out completely and prints can no longer be made, the message <Replace the toner.> appears on the touch panel display. Pressing [Recover Later] enables you to continue operations. However, you have to replace the toner cartridge to make further prints.

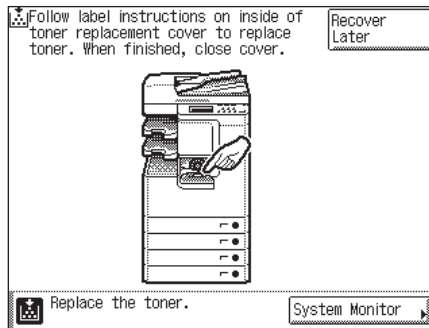

## **WARNING**

- Do not burn or throw used toner cartridges into open flames, as this may cause the toner remaining inside the cartridges to ignite, resulting in burns or a fire.
- Do not store toner cartridges or paper in places exposed to open flames, as this may cause the toner or paper to ignite, resulting in burns or a fire.

- If you accidentally spill or scatter toner, carefully gather the toner particles together or wipe them up with a soft, damp cloth in a way that prevents inhalation.  
Never use a vacuum cleaner that does not have safeguards against dust explosions to clean up spilled toner. Doing so may cause a malfunction in the vacuum cleaner, or result in a dust explosion due to static discharge.

### CAUTION

- Keep toner out of the reach of small children. If toner is ingested, consult a physician immediately.
- Take care not to allow toner to come into contact with your hands or clothing. If toner gets onto your hands or clothing, wash it off immediately with cold water. Washing with warm water may set the toner permanently, making the stains impossible to remove.
- When discarding used toner cartridges, put the cartridges in a bag to prevent the toner remaining inside the cartridges from scattering, and dispose of them in a location away from open flames.

### IMPORTANT

- Use only toner cartridges intended for use with the machine. (See “Consumables,” on p. 5-18.)
- Do not replace toner cartridges until the message prompting you to do so appears.
- Do not attempt to replace the toner cartridge while the machine is printing.

### NOTE

If toner runs out during a print job, the remaining prints are completed after you replace the toner cartridge.

1

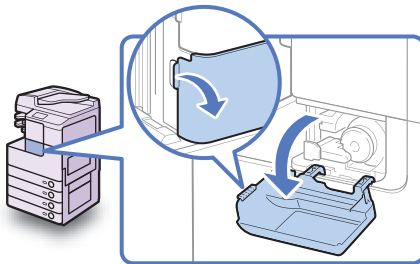

Open the toner replacement cover.

2

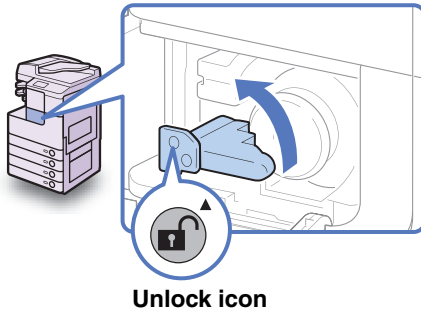

Turn the locking lever counterclockwise until it becomes vertical.

**IMPORTANT**

Make sure that the down arrow (▼) on the locking lever is aligned with the up arrow (▲) of the Unlock icon position before proceeding.

3

**Pull the toner cartridge out of the toner supply port.**

Pull the toner cartridge out halfway with one hand, support it with the other hand from underneath, and then remove it completely while keeping it level.

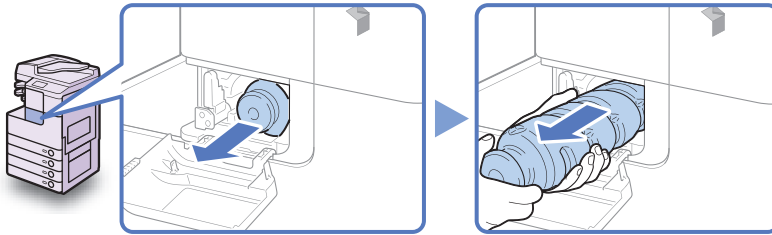
**WARNING**

Do not burn or throw used toner cartridges into open flames, as this may ignite the toner remaining inside the cartridge, and result in burns or a fire.

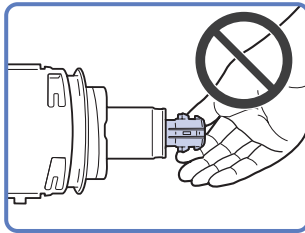
**IMPORTANT**

- If the toner cartridge cannot be pulled out, check that the knob is turned all the way to the appropriate position.
- Do not touch the opening of the toner cartridge or subject it to shock by hitting it. Doing so may cause the toner to leak out of the cartridge.

## 4 Take the new toner cartridge out of the package and uncap it.

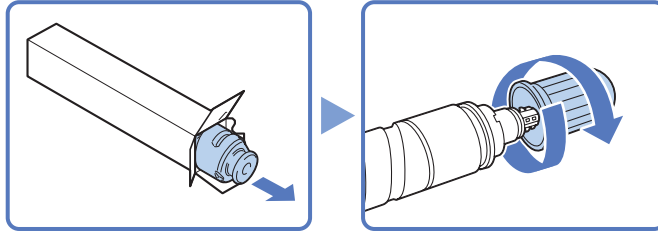

### IMPORTANT

- Use only toner cartridges intended for use with the machine. (See “Consumables,” on p. 5-18.)
- Do not touch the opening of the toner cartridge or subject it to shock by hitting it. Doing so may cause the toner to leak out of the cartridge.

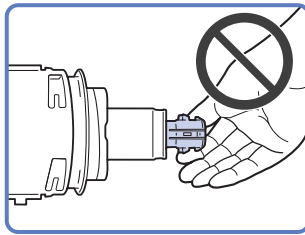

## 5 Insert the new toner cartridge in the toner supply port as far as it will go.

Support the new toner cartridge with one hand from underneath while pushing it into the machine with the other hand.

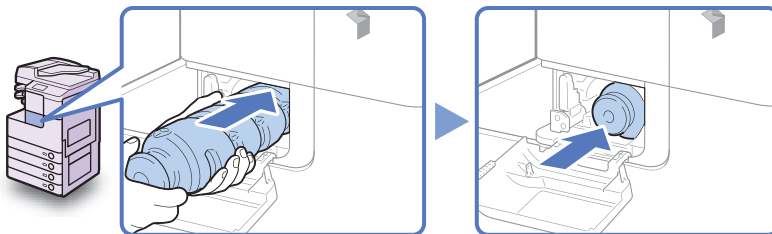

6

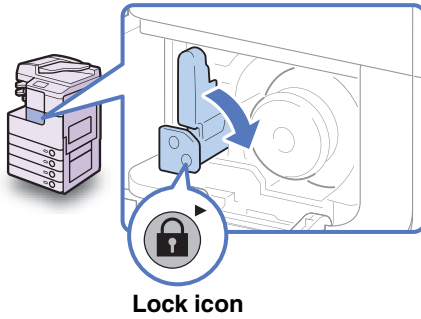

**Return the locking lever to its original position.**



**IMPORTANT**

Make sure that the down arrow (▼) on the locking lever is aligned with the right arrow (►) of the Lock icon position.

7

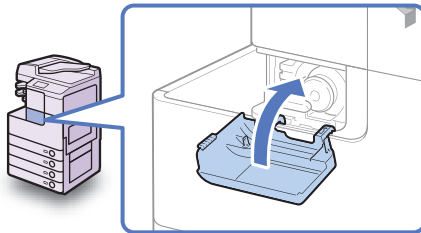

**Close the toner replacement cover.**



**CAUTION**

When closing the cover, be careful not to get your fingers caught, as this may result in personal injury.



**IMPORTANT**

Make sure that you clean the fixing unit every time you replace the toner cartridge. (See Chapter 5, “Routine Maintenance,” in the *Reference Guide*.)

# Routine Cleaning

If the original is not copied clearly, clean the following parts of the machine:

- Platen glass
- Underside of the feeder/platen cover
- Feeder scanning area and rollers

For high-quality printouts, we recommend that you clean these parts regularly.

## WARNING

- When cleaning the machine, first turn OFF the main power switch, then disconnect the power cord. Failure to observe these steps may result in a fire or electrical shock.
- Do not use alcohol, benzene, paint thinner, or other solvents for cleaning. Doing so may damage the plastic parts.
- Disconnect the power cord from the power outlet regularly, and clean the area around the base of the power plug's metal pins and the power outlet with a dry cloth to ensure that all dust and grime is removed. If the power cord is connected for a long period of time in a damp, dusty, or smoky location, dust can build up around the power plug and become damp. This may cause a short circuit and result in a fire.

## IMPORTANT

- Do not dampen the cloth too much, as excess water may damage the machine.
- Turning the main power OFF will erase all jobs in the machine's memory.

## Platen Glass and Cover

Clean the platen glass and the underside of the feeder/platen cover as described below.

## IMPORTANT

If the platen glass or the underside of the feeder/platen cover is dirty, the original may not be scanned clearly, or the size of the original may be incorrectly detected.



- 1 Clean the platen glass and the underside of the feeder/platen cover with a water-moistened cloth, and then wipe them clean with a soft, dry cloth.

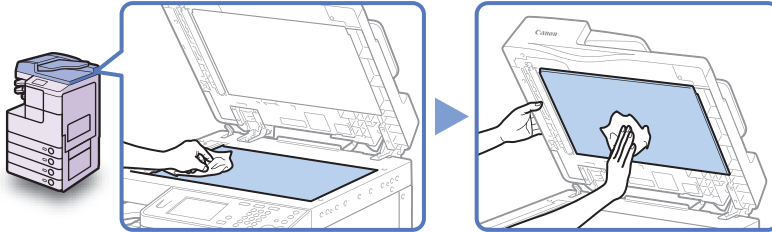

 **IMPORTANT**

Do not dampen the cloth too much, as excess water may damage the machine.

## Feeder Scanning Area and Rollers

Clean the feeder scanning area and rollers regularly as described below.

 **IMPORTANT**

Do not dampen the cloth too much, as excess water may damage the machine.

 **NOTE**

The Feeder (DADF-AA1/-AB1) is optional for the imageRUNNER 2545/2535/2530/2525/2520.

1

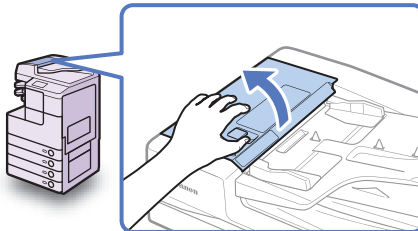

**Open the feeder cover.**

2

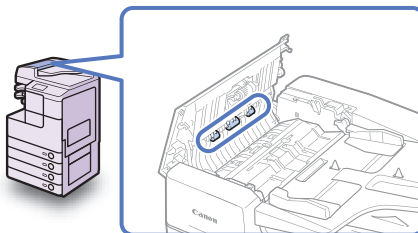

**Clean the rollers (a total of three places) inside the feeder cover with a water-moistened cloth. Then, wipe the area with a soft, dry cloth.**

Spin the rollers with your hand while cleaning them.

**3** Open the inner cover, holding it by the front tab.

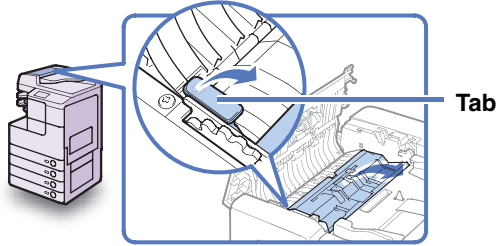

**4**

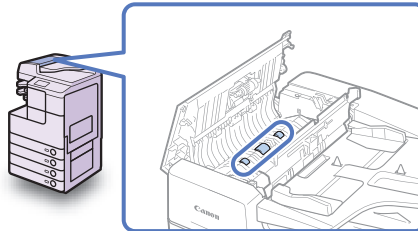

**Clean the rollers (a total of three places) inside the inner cover with a water-moistened cloth. Then, wipe the area with a soft, dry cloth.**

Spin the rollers with your hand while cleaning them.

**5**

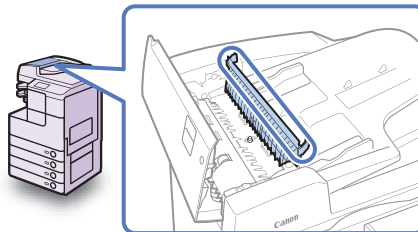

**Clean the transparent plastic part of the inner cover with a water-moistened cloth. Then, wipe the area with a soft, dry cloth.**

**6**

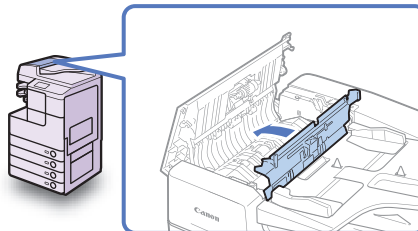

**Close the inner cover.**

**⚠ CAUTION**

**When closing the cover, be careful not to get your fingers caught, as this may result in personal injury.**

- 7** Place your index finger on the feed dial. Without releasing the finger from the feed dial, open the feeder.

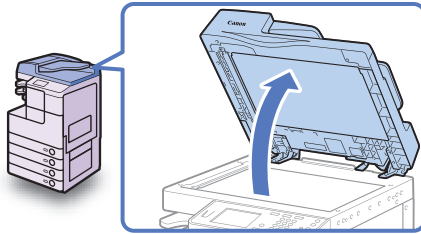
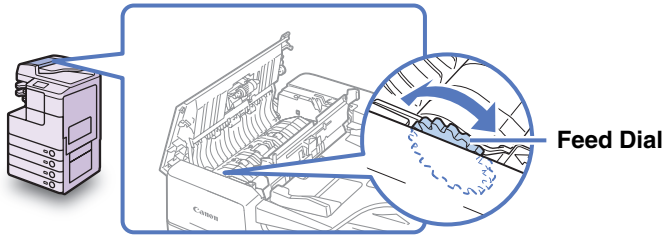

- 8** While using the feed dial to turn the resin roller, wipe the resin roller and its surroundings with a water-moistened cloth. Then, wipe the area with a soft, dry cloth.

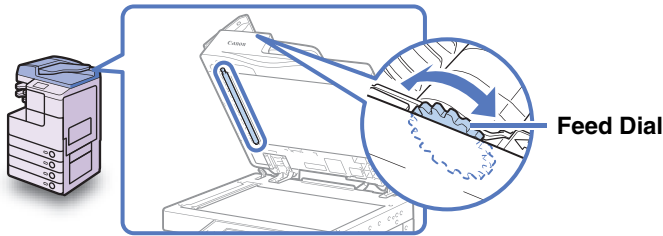

 **NOTE**

If the feed dial cannot be reached while the feeder is opened, close the feeder → turn the feed dial slightly → open the feeder → clean the roller. Repeat these steps until the roller surface is completely clean.

9

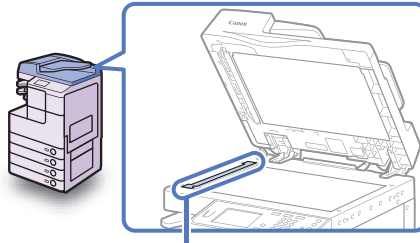

Feeder Scanning Area

Clean the feeder scanning area (the left side of the platen glass) with a water-moistened cloth. Then, wipe the area with a soft, dry cloth.

10

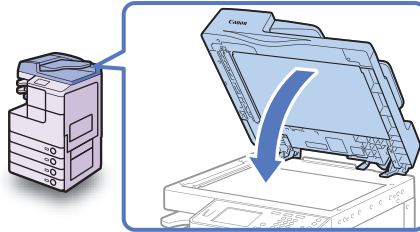

Close the feeder.

**CAUTION**

- When closing the feeder, be careful not to get your fingers caught, as this may result in personal injury.
- Be aware that the light emitted from the platen glass may be very bright when closing the feeder.

11

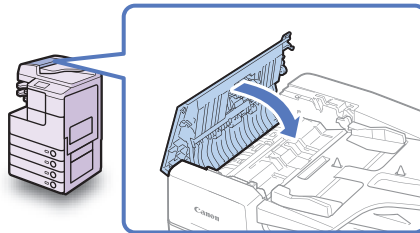

Close the feeder cover.

**CAUTION**

- When closing the cover, be careful not to get your fingers caught, as this may result in personal injury.

# Consumables

The consumables described in this section are available from Canon. For more information, contact your local authorized Canon dealer.

We recommend that you order these consumables from your local authorized Canon dealer before your stock runs out.

## CAUTION

**Keep toner and other consumables out of the reach of small children. If these items are ingested, consult a physician immediately.**

## Paper Stock

In addition to plain paper (A4, A3, A5, B4, and B5), recycled paper, color paper, transparencies (recommended for the machine), labels, and other types of paper stock are available. For more information, contact your local authorized Canon dealer.

## CAUTION

**Do not store paper in places exposed to open flames, as this may cause the paper to ignite, resulting in burns or a fire.**

## IMPORTANT

To prevent moisture build-up, tightly wrap any remaining paper in its original package for storage.

## NOTE

- For high-quality printouts, use paper recommended by Canon.
- Some commercially available paper types are not suitable for this machine. Contact your local authorized Canon dealer when you need to purchase paper.

# Toner

If a message prompting you to replace the toner cartridge appears on the touch panel display, replace the toner cartridge with a new one. Use only toner cartridges intended for use with the machine.

For optimum print quality, using Canon genuine toner is recommended.

Product Name	Supported Canon Genuine Toner
imageRUNNER 2545i/2545/2535i/2535	Canon NPG-50 Black Toner
imageRUNNER 2530/2525i/2525/2520i/2520	Canon NPG-51 Black Toner

## WARNING

- Do not burn or throw used toner cartridges into open flames, as this may cause the toner remaining inside the cartridges to ignite, resulting in burns or a fire.
- Do not store toner cartridges in places exposed to open flames, as this may cause the toner to ignite and result in burns or a fire.
- If you accidentally spill or scatter toner, carefully gather the toner particles together or wipe them up with a soft, damp cloth in a way that prevents inhalation.  
Never use a vacuum cleaner that does not have safeguards against dust explosions to clean up spilled toner. Doing so may cause a malfunction in the vacuum cleaner, or result in a dust explosion due to static discharge.

## CAUTION

Keep toner and other consumables out of the reach of small children. If these items are ingested, consult a physician immediately.

## IMPORTANT

- Store toner cartridges in a cool location, away from direct sunlight. The recommended storage conditions are temperatures below 30°C, and humidity below 80%.
- Do not store toner cartridges in an upright position.

## ***Be careful of counterfeit toners***

Please be aware that there are counterfeit Canon toners in the marketplace. Use of counterfeit toner may result in poor print quality or machine performance. Canon is not responsible for any malfunction, accident or damage caused by the use of counterfeit toner.

For more information, see <http://www.canon.com/counterfeit>.

## Stamp Ink Cartridge

The stamp ink cartridge is used to stamp originals. Use the tweezers provided to remove and replace the stamp ink cartridge.

### ■ Stamp Ink Cartridge-C1



#### IMPORTANT

The Stamp mode is available only when the optional Stamp Unit-B1 is attached to the feeder (optional for the imageRUNNER 2545/2535/2530/2525/2520).

## Staple Cartridge

If a message prompting you to load new staples appears on the touch panel display, replace the staple cartridge with a new one. Use only staple cartridges intended for use with the machine.

### ■ Staple-J1



#### IMPORTANT

The Staple mode is available only when the optional Inner Finisher-B1 is attached to the machine.

# Troubleshooting

# 6

## CHAPTER

This chapter describes how to solve problems you may face when operating the machine.

---

<b>Clearing Paper Jams</b> .....	<b>6-2</b>
Fixing Unit .....	6-3
Paper Drawers 1 and 2 .....	6-5
Feeder .....	6-9
<b>Service Call Message</b> .....	<b>6-12</b>
Restarting the Machine .....	6-12
Using the Machine with Limited Functions .....	6-13
Requesting Repairs from the Control Panel .....	6-14
Contacting Your Local Authorized Canon Dealer .....	6-16



# Clearing Paper Jams

If paper is jammed inside the machine, a screen such as shown below appears on the touch panel display. Use this screen to immediately locate and clear the paper jam.

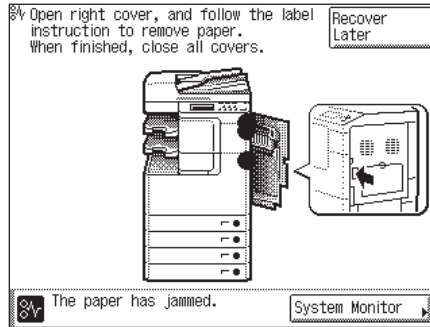

6

Troubleshooting

## WARNING

There are some areas inside the machine which are subject to high-voltages. When removing jammed paper or when inspecting the inside of the machine, do not allow necklaces, bracelets, or other metal objects to touch the inside of the machine, as this may result in burns or electrical shock.

## CAUTION

- When removing jammed originals or paper, take care not to cut your hands on the edges of the original or paper.
- When removing paper which has become jammed inside the machine, take care not to cut your hands or injure yourself on the parts on the inside of the machine. If you cannot remove the paper, please contact your local authorized Canon dealer.
- When removing paper which has become jammed inside the machine, take care not to allow the toner on the jammed paper to come into contact with your hands or clothing, as this will dirty your hands or clothing. If they become dirty, wash immediately with cold water. Washing with warm water may set the toner and make it impossible to remove the toner stains.
- When removing paper which has become jammed inside the machine, remove the jammed paper gently to prevent the toner on the paper from scattering and getting into your eyes or mouth. If the toner gets into your eyes or mouth, wash immediately with cold water and immediately consult a physician.

- The fixing unit and its surroundings inside the machine may become hot during use. When removing jammed paper or when inspecting the inside of the machine, do not touch the fixing unit and its surroundings, as this may result in burns or electrical shock.
- After clearing all paper jams, remove your hands from the machine immediately. Even if the machine is not in operation, your hands, hair, or clothing may get caught in the feed rollers, which could result in personal injury or damage if the machine suddenly starts printing.



#### IMPORTANT

After you have cleared all the paper jams, make sure to return all the levers and covers to their original positions. Once you have removed all of the jammed paper, printing resumes.



#### NOTE

When all the paper jams are cleared, the machine automatically recalculates the number of copies or prints to make. You do not need to re-enter the number of copies or prints, even if you are printing multiple sets.

## Fixing Unit

If paper is jammed in the fixing unit, remove the jammed paper as described below.

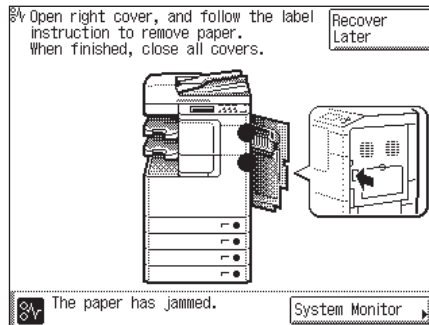

#### CAUTION

The fixing unit and its surroundings are subject to high temperatures. When removing jammed paper, do not touch anything in this area except the jammed paper or the upper cover.

- 1 Press the button on the right cover of the main unit, and open the right cover.

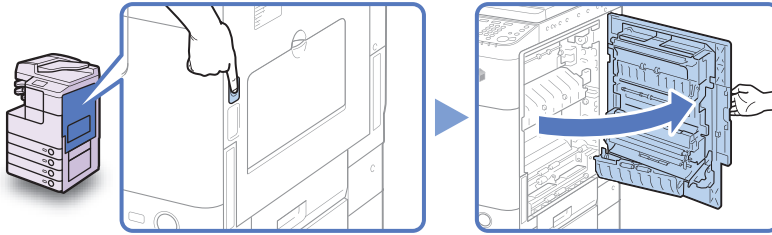

- 2 Remove any jammed paper protruding from the lower part of the fixing unit.

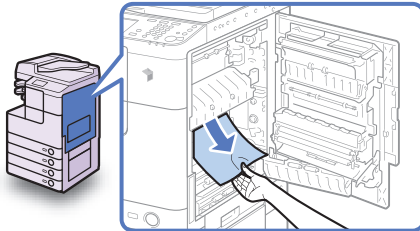

- 3 Pull down the upper cover of the fixing unit by the tab, and remove any jammed paper.

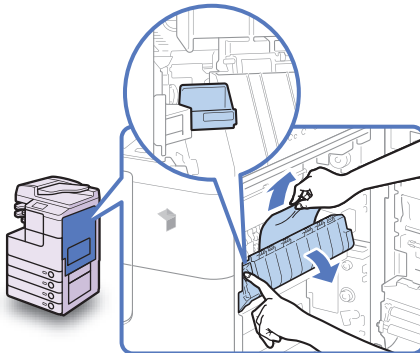

**⚠ CAUTION**

The fixing unit and its surroundings are subject to high temperatures. When removing jammed paper, do not touch anything in this area except the jammed paper or the upper cover.

4

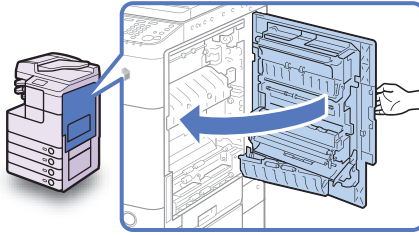

Place your hand where the hand symbol (☞) is located on the right cover of the main unit, and then gently close the right cover until it clicks into place.

**CAUTION**

When closing the cover, be careful not to get your fingers caught, as this may result in personal injury.



**IMPORTANT**

After you have cleared all the paper jams, make sure to return all the levers and covers to their original positions. Once you have removed all of the jammed paper, printing resumes.

## Paper Drawers 1 and 2

If paper is jammed inside Paper Drawers 1 and 2, remove the jammed paper as described below.

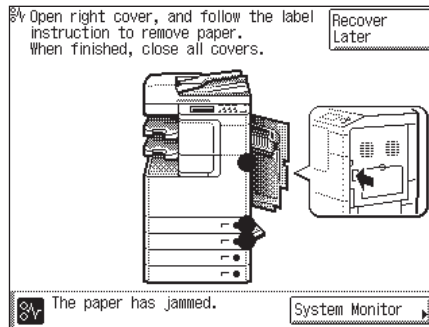

**IMPORTANT**

The procedure described in this section assumes that the machine is equipped with four paper drawers. The number of available paper drawers may vary depending on the machine configuration.

- 1** Press the button on the right cover of the main unit, and open the right cover.

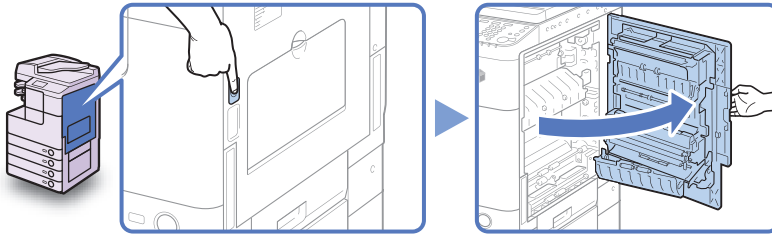

- 2** Remove any jammed paper.

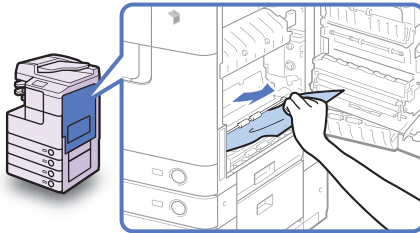

- 3** Open the paper drawer's right cover, and remove any jammed paper.

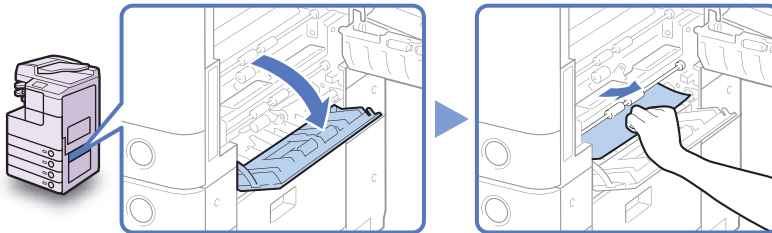

- 4** Press the button on Paper Drawer 1, and pull out the drawer until it stops.

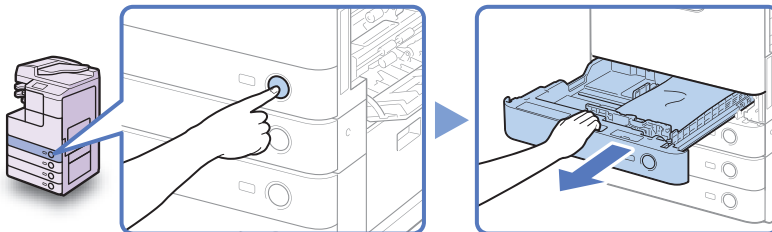

5

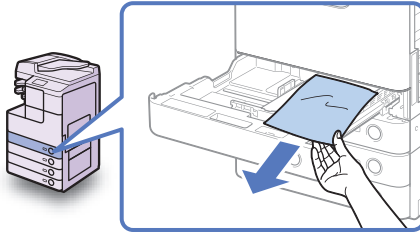

Remove any jammed paper.

6

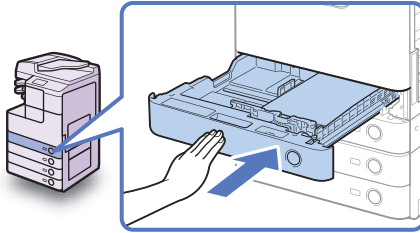

Gently push the drawer back into the machine until it clicks into place.

**⚠ CAUTION**

When returning the paper drawer to its original position, be careful not to get your fingers caught, as this may result in personal injury.

7

Press the button on the Paper Drawer 2, and pull out the drawer until it stops.

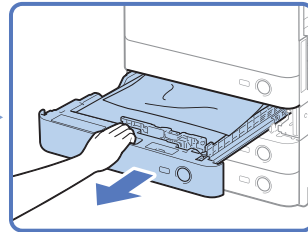
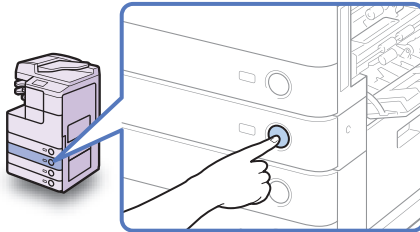

8

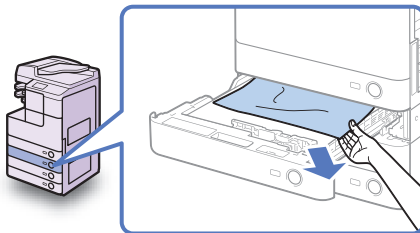

Remove any jammed paper.

9

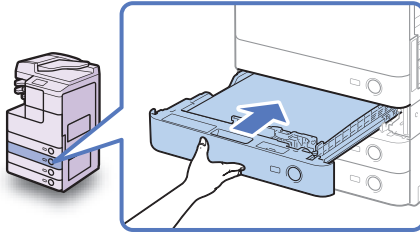

Gently push the drawer back into the machine until it clicks into place.

**CAUTION**

When returning the paper drawer to its original position, be careful not to get your fingers caught, as this may result in personal injury.

10

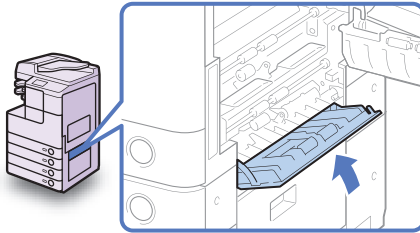

Close the paper drawer's right cover.

**CAUTION**

When closing the cover, be careful not to get your fingers caught, as this may result in personal injury.

11

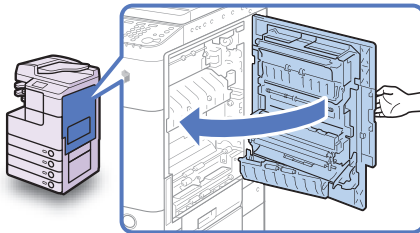

Place your hand where the hand symbol (👉) is located on the right cover of the main unit, and then gently close the right cover until it clicks into place.

**CAUTION**

When closing the cover, be careful not to get your fingers caught, as this may result in personal injury.



**IMPORTANT**

After you have cleared all the paper jams, make sure to return all the levers and covers to their original positions. Once you have removed all of the jammed paper, printing resumes.

# Feeder

If paper is jammed in the feeder, remove the jammed paper as described below.

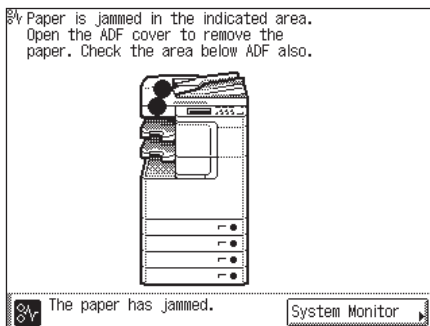

## IMPORTANT

The Feeder (DADF-AA1/-AB1) is optional for the imageRUNNER 2545/2535/2530/2525/2520.

1

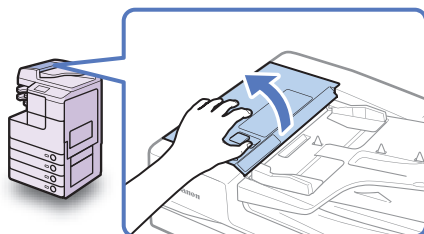

Open the feeder cover.

2

Open the inner cover, holding it by the front tab.

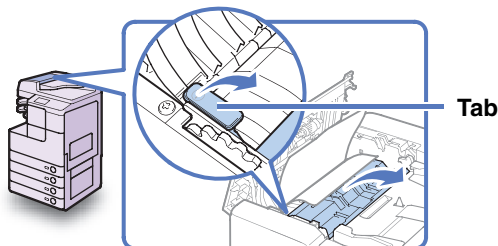

6

Troubleshooting



### 3 Turn the feed dial and remove any jammed originals.

Do not pull the original forcibly, because it may tear.

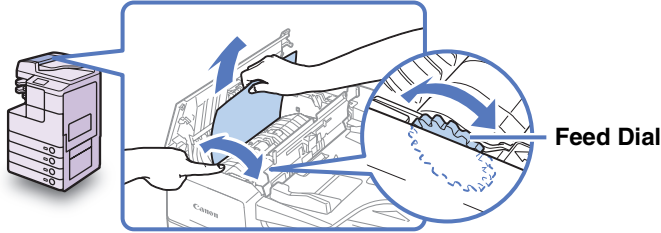

### 4 Close the inner cover, and then the feeder cover.

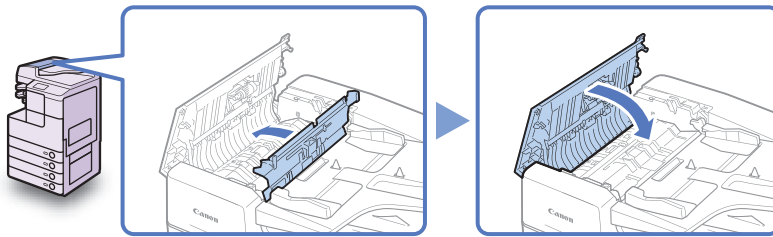

#### **CAUTION**

When closing the covers, be careful not to get your fingers caught, as this may result in personal injury.

### 5 Lift the feeder and check for any jammed originals left inside.

If you find any jammed originals left in the feeder, repeat the procedure from step 1. Do not pull the original forcibly, because it may tear.

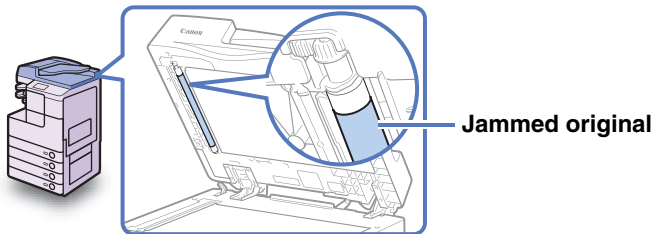

6

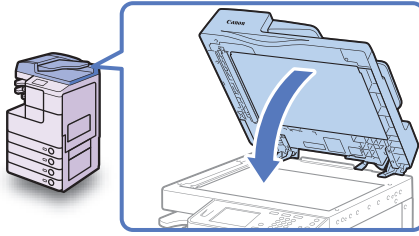

**Close the feeder.**

**⚠ CAUTION**

- When closing the feeder, be careful not to get your fingers caught, as this may result in personal injury.
- Be aware that the light emitted from the platen glass may be very bright when closing the feeder.



**IMPORTANT**

After you have cleared all the paper jams, make sure to return all the levers and covers to their original positions. Once you have removed all of the jammed paper, printing resumes.

# Service Call Message

If any critical error occurs that prevents normal operations, a service call message is displayed on the screen. If the screen similar to the one shown below is displayed, follow the procedures described below.

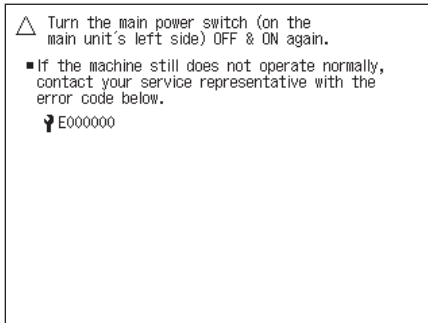

6

Troubleshooting

## Restarting the Machine

If a service call message is displayed, restart the machine.



### IMPORTANT

If the main power is turned OFF, all the jobs in the machine's memory will be erased.

**1** Turn OFF the machine's main power.

**2**

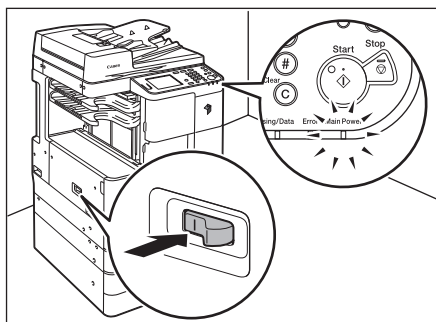

**Wait at least 10 seconds and turn the main power back ON.**

## Using the Machine with Limited Functions

If the Service Call Message screen appears indicating a malfunction of the optional finisher, you can clear the screen by setting the machine to the Limited Functions Mode. In this mode, you can continue operating the machine by disabling the finisher functions.



### IMPORTANT

If the main power is turned OFF, all the jobs in the machine's memory will be erased.



### NOTE

- Setting the machine to the Limited Functions Mode from the Service Call Message screen enables the Limited Functions Mode in Common Settings. (See Chapter 3, “Configuring the Machine’s Basic Settings,” in the *Reference Guide*.)
- The Service Call Message screen may re-appear if the Limited Functions Mode is deactivated without isolating the cause of the malfunction.

1

△ Turn the main power switch (on the main unit's left side) OFF & ON again.

- If the machine still does not operate normally, contact your service representative with the error code below.  
123456789012  
The finisher output tray cannot move up or down. Make sure that objects are not placed in the range of tray movement.
- If the device does not function correctly even after the main power switch was turned OFF and then ON again, press [Limited Fnctns Mode] to continue operation using limited functions.

[Limited Fnctns Mode] [Shutdown]

Press [Limited Fnctns Mode].



### NOTE

If you want to turn OFF the machine, press [Shutdown].

2

△ Turn the main power switch (on the main unit's left side) OFF & ON again.

- Is it OK to turn limited functions mode ON? If you press [Yes], functions will be limited.
- continue operation using limited functions.

[Yes] [No]

[Limited Fnctns Mode] [Shutdown]

Press [Yes].

To quit, press [No].

3

Restart the machine.

Turn OFF the machine, wait at least 10 seconds, and then turn it ON.

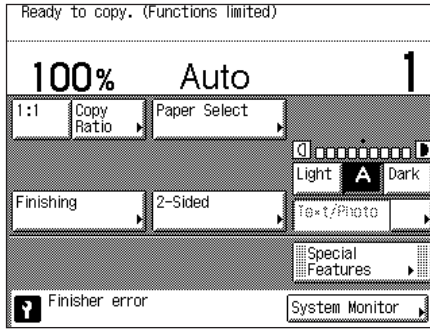

The machine starts up in the Limited Functions Mode.



**NOTE**

After the problem with the finisher is solved, disable the Limited Functions Mode from the Additional Functions menu. (See Chapter 3, “Configuring the Machine’s Basic Settings,” in the *Reference Guide*.)

## Requesting Repairs from the Control Panel

If you notice an abnormality with the machine, you can send a repair request from the touch panel display.

**WARNING**

**Do not connect or disconnect the power cord with wet hands, as this may result in electrical shock.**

**CAUTION**

**Always grasp the power plug portion when disconnecting the power cord. Pulling on the cord may expose or snap the core wire or otherwise damage the power cord. If the power cord is damaged, this could cause current to leak, resulting in a fire or electrical shock.**

**IMPORTANT**

To make repair requests from the touch panel display, the machine must be configured beforehand. For more information, contact your local authorized Canon dealer.

**1**

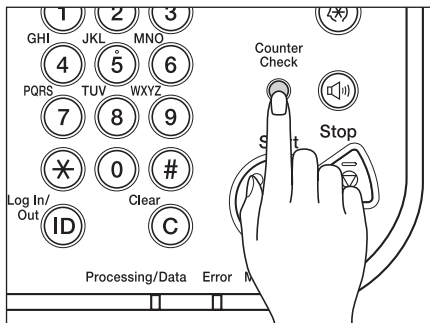

**Press [Counter Check] on the control panel.**

2

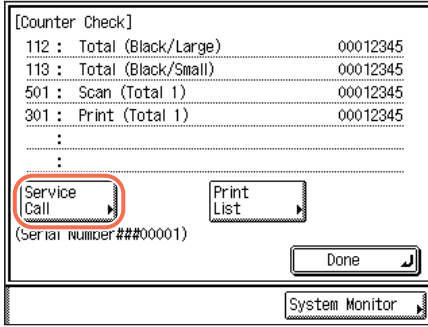

Press [Service Call].

3

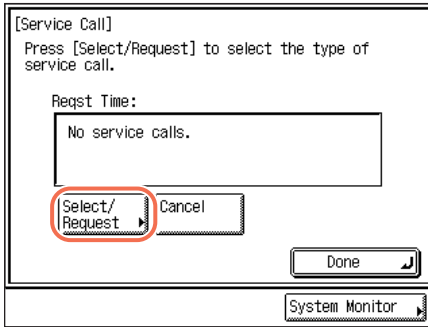

Press [Select/Request].

**NOTE**  
You can cancel the request by pressing [Cancel] → [Yes].

4

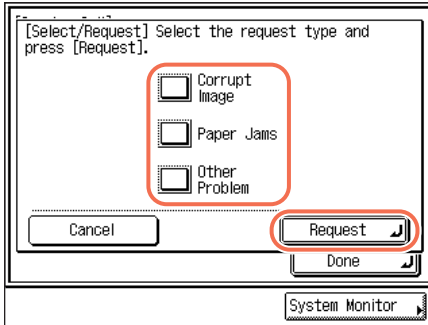

Press [Corrupt Image], [Paper Jams], or [Other Problem] to select the type of the problem you want to fix → press [Request].

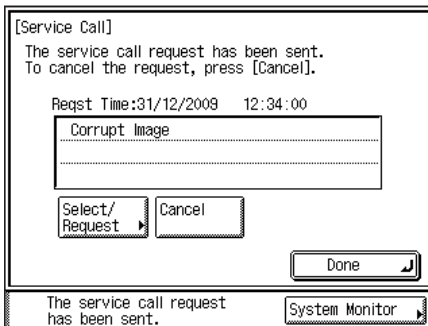

The screen on the left appears when your request has successfully been sent.

**NOTE**  
You can cancel the request by pressing [Cancel] → [Yes].

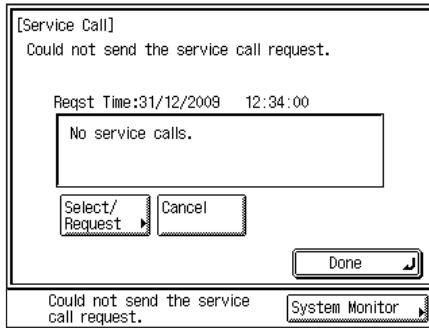

The screen on the left appears when the transmission of your request has failed. Try again.



#### NOTE

If you cannot send repair requests despite several attempts, turn OFF the main power and disconnect the power cord from the wall outlet. Contact your local authorized Canon dealer with the following information:

- Product name
- Problem and status of the machine
- The error code displayed on the screen

## Contacting Your Local Authorized Canon Dealer

If you have any problems or inquiries concerning the machine, contact your local authorized Canon dealer with the following information:

- Product name
- Problem and status of the machine
- The error code displayed on the screen, if any

If the machine does not operate normally even after it is restarted, turn OFF the main power and disconnect the power cord from the wall outlet.



#### WARNING

**Do not connect or disconnect the power cord with wet hands, as this may result in electrical shock.**



#### CAUTION

**Always grasp the power plug portion when disconnecting the power cord. Pulling on the cord may expose or snap the core wire or otherwise damage the power cord. If the power cord is damaged, this could cause current to leak, resulting in a fire or electrical shock.**



#### IMPORTANT

Even if a blackout occurs or the machine is turned OFF, a built-in battery retains the documents received in memory for about an hour. However, if the battery is not fully charged, the documents may not be retained. (To fully charge the built-in battery, it takes about two hours after the main power switch is turned ON.)

# Appendix

# 7

## CHAPTER

This chapter describes the types of paper that can be used with the machine and includes the index.

---

Available Paper Stock . . . . .	7-2
Index . . . . .	7-4



# Available Paper Stock

The paper types and sizes that can be used with this machine are shown on the tables below.

✓: Available    N/A: Not Available

Paper Type	Paper Source	
	Paper Drawer (64 to 90 g/m <sup>2</sup> )	Stack Bypass (64 to 128 g/m <sup>2</sup> )
Plain <sup>*1</sup>	✓	✓
Recycled <sup>*1</sup>	✓	✓
Color <sup>*1</sup>	✓	✓
3-hole punch	✓	✓
Bond <sup>*2</sup>	N/A	✓
Heavy Paper 1 <sup>*3</sup>	N/A	✓
Heavy Paper 2 <sup>*4</sup>	N/A	✓
Heavy Paper 3 <sup>*5</sup>	N/A	✓
Transparency <sup>*6</sup>	N/A	✓
Labels	N/A	✓

\*1 From 64 to 90 g/m<sup>2</sup>.

\*2 From 75 to 90 g/m<sup>2</sup>.

\*3 From 81 to 90 g/m<sup>2</sup>.

\*4 From 91 to 105 g/m<sup>2</sup>.

\*5 From 106 to 128 g/m<sup>2</sup>.

\*6 Use only A4 transparencies made especially for this machine.

## NOTE

- For instructions on how to register paper types for the paper drawers, see Chapter 3, “Configuring the Machine’s Basic Settings,” in the *Reference Guide*.
- For instructions on how to register paper types for the stack bypass, see Chapter 2, “Basic Operations,” and Chapter 3, “Configuring the Machine’s Basic Settings,” in the *Reference Guide*.
- Chlorine-free paper can be used with this machine.

✓: Available N/A: Not Available

Paper Size		Dimensions	Paper Source		
			Paper Drawers 1/3/4	Paper Drawer 2	Stack Bypass
A4		297 mm × 210 mm	✓	✓	✓
A4R		210 mm × 297 mm	✓	✓	✓
A3		297 mm × 420 mm	✓	✓	✓
A5R		148 mm × 210 mm	✓	✓	✓
B4		257 mm × 364 mm	✓	✓	✓
B5		257 mm × 182 mm	✓	✓	✓
B5R		182 mm × 257 mm	✓	✓	✓
Irregular Size		99 mm to 297 mm × 148 mm to 432 mm	N/A	N/A	✓
Envelope	No.10 (COM10)	104.7 mm × 241.3 mm	N/A	Optional*	✓
	ISO-B5	176 mm × 250 mm	N/A	Optional*	✓
	Monarch	98.4 mm × 190.5 mm	N/A	Optional*	✓
	ISO-C5	162 mm × 229 mm	N/A	Optional*	✓
	DL	110 mm × 220 mm	N/A	Optional*	✓

\* Envelopes can be loaded in Paper Drawer 2 only when the optional Envelope Feeder Attachment-D1 is attached.

 **NOTE**

- For instructions on how to load paper, see the sections listed below.

Paper Drawers 1/2/3/4	Paper	See “Loading Paper,” on p. 5-3.
	Envelope (Drawer 2)	See Chapter 5, “Routine Maintenance,” in the <i>Reference Guide</i> .
Stack Bypass		See Chapter 2, “Basic Operations,” in the <i>Reference Guide</i> .

- The number of available paper drawers may vary depending on the machine configuration.

## Numerics

100BASE-TX, 1-10  
10BASE-T, 1-10  
3-hole punch paper, 7-2

## A

Abbreviations used in this manual, ix  
Available features, xii

## B

Basic functions  
Copy, 4-2  
Fax, 4-10  
Media Print, 4-6  
Print, 4-4  
Remote Scan, 4-12  
Remote UI, 4-14  
Send, 4-8  
Bond paper, 7-2

## C

Cable connection  
Network, 1-10  
Telephone, 1-12  
USB, 1-9  
Canon dealer, 6-16  
Cassette Heater Unit-37, 2-2  
Cleaning  
Feeder scanning area and rollers, 5-14  
Platen glass and cover, 5-13  
Routine cleaning, 5-13  
Color Network ScanGear, 3-4

Color paper, 7-2  
Consumables  
Paper stock, 5-18  
Stamp ink cartridge, 5-20  
Staple cartridge, 5-20  
Toner, 5-19  
Control panel power switch, 2-4  
Copying, 4-2  
Copying, Definition of, xi

## D

Displays used in this manual, ix

## E

Ethernet  
100BASE-TX, 1-10  
10BASE-T, 1-10

## F

Fax Driver, 3-14  
Fax Driver Installation Guide, 3-14  
Fax Driver Software, 3-14  
Faxing, 4-10  
Feeder scanning area, 5-17  
Feeder, Cleaning, 5-14  
Font Manager, 3-9  
Front guide, 5-6

## H

Handling precautions, 1-7  
Heavy paper, 7-2

## I

Illustrations used in this manual, viii  
Installation  
    Installation space, 1-6  
    Location and handling, 1-2  
    Power supply, 1-4  
    Precautions, 1-2  
    Safety instructions, xix

## K

Keys and buttons used in this manual, viii

## L

Labels, 7-2  
Limited Functions Mode, 6-13  
Loading limit mark, 5-4, 5-6  
Loading paper  
    Paper drawers, 5-2

## M

Mac PS Printer Driver, 3-11  
Mac PS Printer Driver Installation Guide, 3-11  
Mac UFR II Printer Driver Installation Guide, 3-4  
Mac UFR II LT Printer Driver, 3-4  
Main power, 2-2  
Media Print, 4-6  
Moving the machine, 1-6

## N

Network connection, 1-10  
Network ScanGear Installation Guide, 3-5  
Network scanning, 4-12

## P

Paper jams, 6-2  
    Feeder, 6-9  
    Fixing unit, 6-3  
    Paper Drawers 1 and 2, 6-5  
Paper stock, 5-18  
    Paper size, 7-3  
    Paper type, 7-2  
PCL Printer Driver (PCL5/PCL6), 3-9  
PCL User Software, 3-9  
Plain paper, 7-2  
Printer Driver Installation Guide, 3-4, 3-9, 3-11  
Printing  
    from a computer, 4-4  
    from USB memory media, 4-6  
Printing, Definition of, xi  
PS Printer Driver, 3-11  
PS User Software, 3-11

## R

Recycled paper, 7-2  
Remote Scan, 4-12  
Remote UI, 4-14  
Repair request, 6-14  
Restarting, 6-12  
Routine cleaning, 5-13

## S

- Safety instructions
  - Consumables, xxvi
  - Handling, xxi
  - Installation, xix
  - Maintenance and inspections, xxiv
  - Other warnings, xxvi
  - Power supply, xx
- Scanning, Definition of, x
- Sending
  - e-mail, 4-8
  - I-fax, 4-8
  - to file servers, 4-8
  - to USB memory media, 4-8
- Service call message, 6-12
- Side guide, 5-6
- Sleep mode, 2-4
- Stamp ink cartridge, 5-20
- Staple cartridge, 5-20
- Symbols used in this manual, vii

## 7

## T

- Telephone connection, 1-12
- Toner cartridge, 5-8, 5-19
- Transparency, 7-2
- Troubleshooting
  - Limited functions, 6-13
  - Service call message, 6-12
- TWAIN, 3-4

## U

- UFR II LT Printer Driver, 3-4
- UFR II LT User Software, 3-4
- USB connection, 1-9
- USB memory media printing, 4-6
- User Manual CD-ROM, 3-2



**CANON INC.**

30-2, Shimomaruko 3-chome, Ohta-ku, Tokyo 146-8501, Japan

**CANON U.S.A., INC.**

One Canon Plaza, Lake Success, NY 11042, U.S.A.

**CANON CANADA INC.**

6390 Dixie Road Mississauga, Ontario L5T 1P7, Canada

**CANON EUROPA N.V.**

Bovenkerkerweg 59-61 1185 XB Amstelveen, The Netherlands

(See <http://www.canon-europe.com/> for details on your regional dealer)

**CANON LATIN AMERICA, INC.**

703 Waterford Way Suite 400 Miami, Florida 33126 U.S.A.

**CANON AUSTRALIA PTY. LTD**

1 Thomas Holt Drive, North Ryde, Sydney, N.S.W. 2113, Australia

**CANON CHINA CO., LTD**

15F Jinbao Building No.89 Jinbao Street, Dongcheng District, Beijing 100005, China

**CANON SINGAPORE PTE. LTD.**

1 HarbourFront Avenue #04-01 Keppel Bay Tower, Singapore 098632

**CANON HONGKONG CO., LTD**

19/F., The Metropolis Tower, 10 Metropolis Drive, Hunghom, Kowloon, Hong Kong

