



TEC HINGES



G* GRASS®

TEC SOFT-CLOSE AND TEC SELF-CLOSE

TEC Face Frame Hinge System
Established quality with functional benefits for today's
modern cabinetry.





The perfect solution for your face frame cabinetry. TEC Soft-close, with an integrated soft closing action, and TEC Self-close hinge lines offer a complete range of quality hinges made in the USA.

The TEC hinge system offers a proven technology that makes TEC the first brand choice among face frame hinge systems. Quiet and effortless closing action is guaranteed every time with TEC Soft-close hinges. Sleek in design with the Soft-close mechanism pre-mounted in the hinge cup. TEC Self-close hinges include three dimensional adjustment and a variety of overlays to meet your hinge needs. Made in the USA, TEC hinges are built to last.



TEC SOFT-CLOSE AND TEC SELF-CLOSE HINGE SYSTEMS

Made in the USA, the TEC hinge systems offer a solution for every application in kitchen, bath, and residential cabinetry.

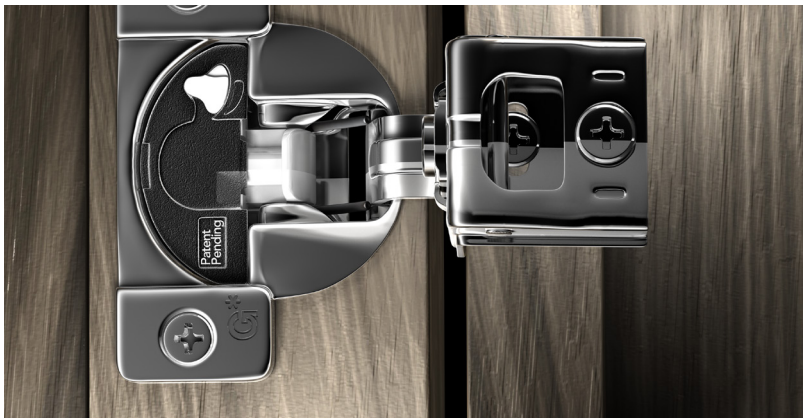

TEC Soft-close – the unique face frame hinge with adjustable soft-close action

The TEC Soft-close hinge system is a revolutionary face frame hinge with the soft-closing mechanism pre-mounted into the interior of the hinge cup. An adjustment switch located on the face of the hinge regulates the closing action of the door. Integrated Soft-close combined with the adjustment feature provides functional benefits for today's modern cabinetry. Made in the USA, your doors will close softly, quietly, and consistently with TEC Soft-close.

Innovative three tiered adjustment

TEC Soft-close hinges feature a three tiered adjustment switch enabling you to regulate the closing action of the door. These adjustments provide different levels of damping resistance in the soft-close mechanism. Set at the highest level, the damping system has the most resistance and provides the longest closing action. To achieve less resistance you can place the adjustment switch at the medium level or lower level. The settings can be different for each hinge on the door so that you can achieve the maximum benefit in your closing action regardless of the size or weight of the door.









TEC Self-close hinge system offers a solution for every cabinet application

The TEC 860 family includes a variety of hinges with three dimensional adjustment to hinges used for MDF material. Each hinge is available in a variety of overlays and in an array of hinge and base plate versions. Constructed of all-steel and nickel-finish components for optimal strength and durability, the TEC hinge systems work on a variety of doors with profiled door edges. Made in the USA, TEC hinges are engineered to last.

TEC Hinges

Table of Content

Opening angle		Description	Adjustments	Page
		Features and Benefits		6
		TEC Technical Information		8
108°		TEC 864 Soft-close <ul style="list-style-type: none"> • 1/4" to 1" overlay • 42mm and 45mm boring patterns 	<ul style="list-style-type: none"> • Height • Side • Depth 	10
108°		TEC 864 Soft-close <ul style="list-style-type: none"> • 1 1/4" to 1 1/2" overlay • 42mm and 45mm boring patterns 	<ul style="list-style-type: none"> • Height • Side • Depth 	12
108°		TEC 863 Face Mount Soft-close and Self-close <ul style="list-style-type: none"> • 1 7/16" minimum overlay • 42mm and 45mm boring patterns 	<ul style="list-style-type: none"> • Height • Side 	14
108°		TEC 864 Self-close <ul style="list-style-type: none"> • 1/4" to 1" overlay • 42mm and 45mm boring patterns 	<ul style="list-style-type: none"> • Height • Side • Depth 	16
108°		TEC 864 Self-close <ul style="list-style-type: none"> • 1 1/4" to 1 1/2" overlay • 42mm and 45mm boring patterns 	<ul style="list-style-type: none"> • Height • Side • Depth 	18
108°		TEC 861 <ul style="list-style-type: none"> • One-piece hinge construction • 42mm and 45mm boring patterns 	<ul style="list-style-type: none"> • Height • Side 	20

Opening angle		Description	Adjustments	Page
108°		<p>TEC 861 MDF</p> <ul style="list-style-type: none"> • One-piece hinge construction for MDF frame material • 42mm boring pattern 	<ul style="list-style-type: none"> • Height • Side 	22
110°		<p>TEC 872</p> <ul style="list-style-type: none"> • Two-piece construction • 1/2" overlay achievable on profile door • 45mm boring pattern 	<ul style="list-style-type: none"> • Height • Side • Depth 	24
		<p>Machinery</p> <ul style="list-style-type: none"> • GRASS PRO 1 • Drill bits • Insertion dies 		26
		<p>Assembly Hardware</p> <ul style="list-style-type: none"> • Bumpers • Spacers • Screws 		28

Features and Benefits

TEC Soft-close

Features



TEC Soft-close hinges are made in the USA of durable and long-lasting materials from time-tested design and manufacturing techniques. Every mechanism is tested for reliability and the user experience.

- One piece hinge and base plate combination
- 3-tier Soft-close adjustment
- 42 and 45mm boring patterns
- For face frame cabinetry
- Made in the USA

TEC Soft-close hinges are offered in these overlays:

1/4", 7/16", 1/2", 5/8", 3/4", 1", 1 1/4", 1 5/16", 1 3/8", 1 1/2", 1 7/16"

3-dimensional adjustment
setting for height, side, and depth

Soft-close damping system
for quiet and effortless closing action

One piece
hinge and base plate construction

Front locating tabs
position hinge on face frame

Low profile cup
allows shallow drilling depth -
11mm (7/16")

Adjustable Soft-close mechanism
integrated into hinge cup with no
protruding parts in the interior of
the cabinet

TEC Self-close

Features



TEC Self-close hinges are made in the USA of durable and long-lasting materials from time-tested design and manufacturing techniques. Every mechanism is tested for reliability and the user experience.

- One piece hinge and base plate combination
- 42 and 45mm boring patterns
- For face frame cabinetry
- Made in the USA

TEC Self-close hinges are offered in these overlays:

1/4", 7/16", 1/2", 9/16", 5/8", 3/4", 1", 1 1/4", 1 5/16", 1 3/8", 1 1/2", 1 7/16"

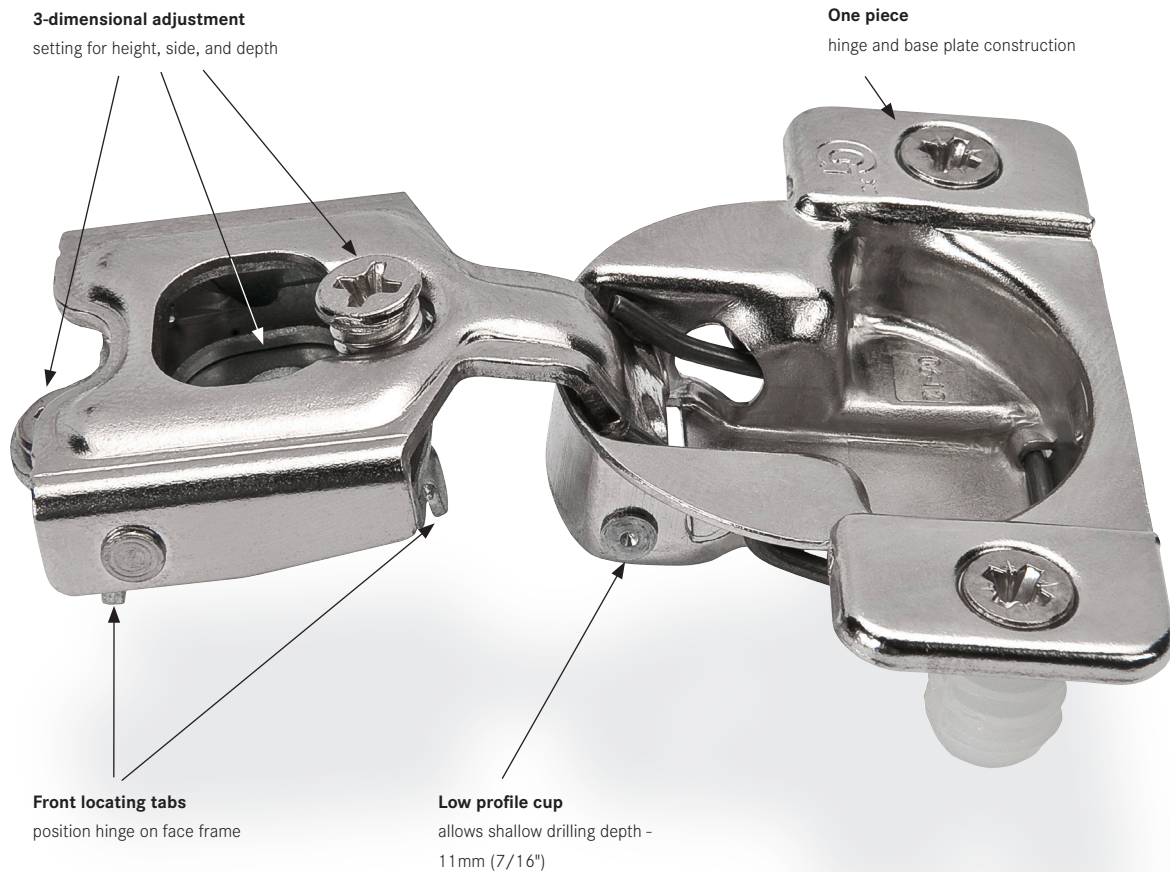

Technical Information

TEC Hinges

Technical Information

There are numerous variables that will determine the choice of hinge. Determine the requirements of the application. Consider the following points based on the door to cabinet application.

- 1 Door overlay
- 2 Adjustment requirements:
 - a. Height only
 - b. Height and side
 - c. Height, side, and depth
- 3 Base plate mounting to face frame:
 - a. Wrap-around - 3/4" thick frames only
 - b. Side mount - frames thicker than 3/4"
 - c. Face mount - any overlay greater than 1 7/16"
 - d. MDF material - mounting into end grain
- 4 Door removal:
 - a. With base plate mounting screw (one-piece hinges)
 - b. With depth adjustment screw (two-piece hinges)
- 5 Door clearance/hinge arm clearance (for interior rollout trays)
- 6 Door gap - distance between face frame and the back of the closed door
- 7 Minimum reveal - distance between two doors hinged back to back
- 8 Door thickness - thicker doors can restrict opening angle and minimum reveal
- 9 Hinge cup boring pattern for dowelled hinges
- 10 Door opening angle
- 11 Soft- or Self-closing

Number of Hinges Per Door

The number of hinges is determined by the door height, door weight, quality of the material and the fixing of the cup and base plate.

The load and height data refer to 24" standard door widths.

Grass strongly recommends a trial mount for all hinges and base plates.

Example:

For doors measuring 56" x 24" and weighing 19lbs, Grass recommends the installation of 3 hinges.

Note: The distance between the top and bottom hinge must be greater than the width of the door.

The **TEC** hinge meets and exceeds the minimum requirements of ANSI/BHMA A 156.9 standard.

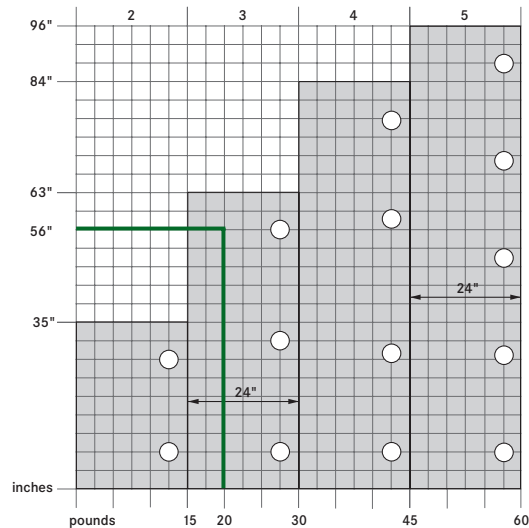

Features

All-steel Construction

TEC hinges feature a solid metal hinge cup. All moving mechanism parts, including pivot pins, linkages and springs are hardened to ensure long-term durability.

Shallow Cup Depth

TEC hinges feature a shallow 11 mm (7/16") cup to accommodate profiled door edge. There are no protruding parts from the hinge cup. ACC140 hinges have a 10mm (13/32") cup depth.

Interchangeable

TEC Soft-close and **Self-close** have the same boring pattern so no change is necessary in your existing setup.

All-steel Construction

3-dimensional adjustment is built into the 864 and 872 hinge series.

2-dimensional adjustment is available for 861, 862, 863, MDF and ACC 140 hinge series.

Integrated Soft-close

The Soft-close damper is pre-mounted in the hinge cup. No additional installation of the Soft-close is required. A three tiered adjustment switch allows various levels of resistance in the damping system.

Made in the USA

TEC hinges are manufactured at the Grass facility in Kernersville, NC.

Technical Information

for TEC Hinges

Adjustments

TEC hinges offer a convenient three dimensional adjustment.

- 1 Side Adjustment
Rotate cam adjustment screw.
- 2 Height Adjustment
Loosen screw, align door, tighten screw.
- 3 Depth Adjustment
Rotate cam screw.

TEC Soft-close hinges offer an adjustable three tier closing mechanism.

- 4 Soft-close Tension - **A** Light, **B** Medium, and **C** Strong settings

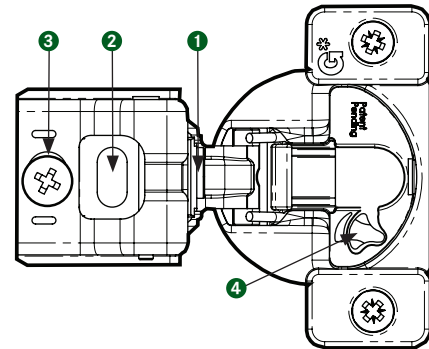

LIGHT

- A** This is the "LIGHT" setting for the Soft-closing mechanism. Set here for light or small doors with very little closing pressure.



MEDIUM

- B** This is the "MEDIUM" setting for the Soft-closing mechanism. Set here for average size doors with normal closing pressure.



STRONG

- C** This is the "STRONG" setting for the Soft-closing mechanism. Set here for larger or heavier doors with a strong closing pressure. **(Factory Setting)**

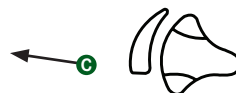

Note: To reset the Soft-close damper, move the adjustment switch to "STRONG", then to the desired position. Close the door and the Soft-close will be reset.

TEC Soft-close

108° Opening Angle - 1/4" to 1" Overlay



- Soft-close damper is pre-mounted in the hinge cup
- Adjustment switch to regulate closing action
- One piece hinge and base plate combination
- 3 dimensional adjustment
- 11mm (7/16") cup drilling depth
- Front locating tabs position hinge on face frame
- Cam side adjustment
- Cam depth adjustment
- Height adjustment at mounting screw
- Works with current GRASS insertion machinery
- Made in the USA



Side-mount - 45mm Drilling Pattern

Overlay	Door Clearance	Arm Clearance	Dowelled Hinge Cup (VS8)			Screw-on Hinge Cup (VS)		
			Description	Item No.	PU	Description	Item No.	PU
12.7 (1/2")	3.5 (1/8)	11 (7/16")	TEC 864-VS8-45U 1/2 SM A-SC	02750A-15	300	TEC 864-VS-45U 1/2 SM A-SC	04423A-15	300
16 (5/8")	0.3 (1/32")	11 (7/16")	TEC 864-VS8-45U 5/8 SM A-SC	01995A-15	300	-	-	300



Wrap-around - 45mm Drilling Pattern

Overlay	Door Clearance	Arm Clearance	Dowelled Hinge Cup (VS8)			Screw-on Hinge Cup (VS)		
			Description	Item No.	PU	Description	Item No.	PU
6 (1/4")	11 (7/16")	14.5 (9/16")	TEC 864-VS8-45U 1/4 WM A-SC	02791A-15	300	TEC 864-VS-45U 1/4 WM A-SC	04429A-15	300
11 (7/16")	5.1 (13/64")	11 (7/16")	TEC 864-VS8-45U 7/16 WM A-SC	02858A-15	300	TEC 864-VS-45U 7/16 WM A-SC	02670A-15	300
12.7 (1/2")	3.5 (1/8")	11 (7/16")	TEC 864-VS8-45U 1/2 WM A-SC	02870A-15	300	TEC 864-VS-45U 1/2 WM A-SC	04431A-15	300
19 (3/4")	0	11 (7/16")	TEC 864-VS8-45U 3/4 WM A-SC	02875A-15	300	TEC 864-VS-45U 3/4 WM A-SC	04432A-15	300
25 (1")	0	11 (7/16")	TEC 864-VS8-45U 1 WM A-SC	02745A-15	300	TEC 864-VS-45U 1 WM A-SC	04441A-15	300



Side-mount - 42mm Drilling Pattern

Overlay	Door Clearance	Arm Clearance	Dowelled Hinge Cup (VS8)		
			Description	Item No.	PU
12.7 (1/2")	3.5 (1/8")	11 (7/16")	TEC 864-VS8-42U 1/2 SM A-SC	02749A-15	300



Wrap-around - 42mm Drilling Pattern

Overlay	Door Clearance	Arm Clearance	Dowelled Hinge Cup (VS8)		
			Description	Item No.	PU
6 (1/4")	11 (7/16")	14.5 (9/16")	TEC 864-VS8-42U 1/4 WM A-SC	02788A-15	300
11 (7/16")	5.1 (13/64")	11 (7/16")	TEC 864-VS8-42U 7/16 WM A-SC	02809A-15	300
12.7 (1/2")	3.5 (1/8")	11 (7/16")	TEC 864-VS8-42U 1/2 WM A-SC	02824A-15	300
19 (3/4")	0	11 (7/16")	TEC 864-VS8-42U 3/4 WM A-SC	02825A-15	300
25 (1")	0	11 (7/16")	TEC 864-VS8-42U 1 WM A-SC	02834A-15	300

Angle Reduction Clip

Description	Item No.	PU
85° Angle reduction clip	80125-42	100

- Reduces opening angle to 85°

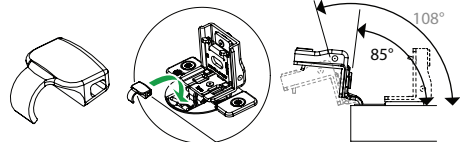

PU - Packaging unit

Dimensions - Door Closed	Minimum Reveal	Clearances - Door Open								
	<p>TEC 864 Minimum Reveal</p> <table border="1"> <tr> <td>Door Thickness</td> <td>16 (5/8")</td> <td>17.5 (11/16")</td> <td>19 (3/4")</td> </tr> <tr> <td>Minimum Reveal</td> <td>4.2 (5/32")</td> <td>5.4 (7/32")</td> <td>6.7 (1/4")</td> </tr> </table> <p>Based on door with square edge.</p>	Door Thickness	16 (5/8")	17.5 (11/16")	19 (3/4")	Minimum Reveal	4.2 (5/32")	5.4 (7/32")	6.7 (1/4")	<p>Arm and door clearances see page 10.</p>
Door Thickness	16 (5/8")	17.5 (11/16")	19 (3/4")							
Minimum Reveal	4.2 (5/32")	5.4 (7/32")	6.7 (1/4")							

Adjustments	Dimensions
-------------	------------

- 1** Side Adjustment +/-1.5mm (1/16")
Rotate cam adjustment screw.
- 2** Height Adjustment +/-2mm (3/32")
Loosen screw, align door, tighten screw.
- 3** Depth Adjustment + 2.5mm (3/32"), -5mm (1/32")
Rotate cam screw.
- 4** Soft-close Tension..... Light, Medium, and Strong setting
See page 9 for complete adjustment explanation

Mounting Screws

Hinge cup to door, #6 x 5/8" Flat head screw
Base plate to face frame, #10 x 3/4" Pan head screw

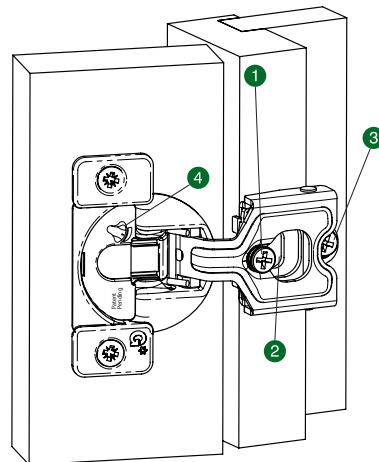

Overall Dimensions

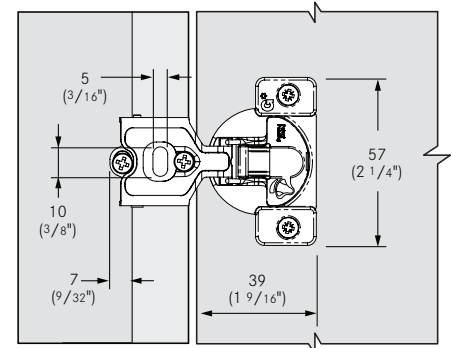

Base Plates	Drilling Pattern
-------------	------------------

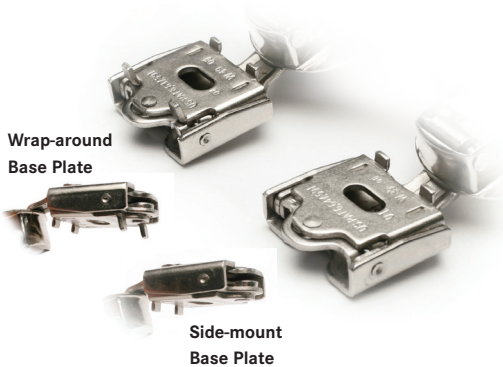

42mm drilling pattern

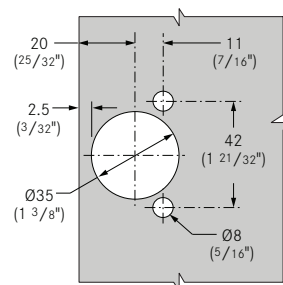

45mm drilling pattern

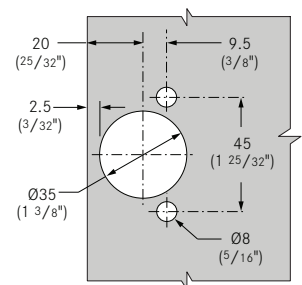

IMPORTANT

To determine the correct application, GRASS strongly recommends a trial mounting for all hinges and base plates.

TEC Soft-close

108° Opening Angle - 1 1/4" to 1 1/2" Overlay



- Soft-close damper is pre-mounted in the hinge cup
- Adjustment switch to regulate closing action
- One piece hinge and base plate combination
- 3 dimensional adjustment
- 11mm (7/16") cup drilling depth
- Front locating tabs position hinge on face frame
- Cam side adjustment
- Cam depth adjustment
- Height adjustment at mounting screw
- Works with current GRASS insertion machinery
- Made in the USA



Side-mount - 45mm Drilling Pattern

Overlay	Door Clearance	Arm Clearance	Dowelled Hinge Cup (VS8)		
			Description	Item No.	PU
32 (1 1/4")	0	10 (13/32")	TEC 864-VS8-45U 1 1/4 SM A-SC	02780A-15	300
35 (1 3/8")	0	10 (13/32")	TEC 864-VS8-45U 1 3/8 SM A-SC	02785A-15	300



Wrap-around - 45mm Drilling Pattern

Overlay	Door Clearance	Arm Clearance	Dowelled Hinge Cup (VS8)			Screw-on Hinge Cup (VS)		
			Description	Item No.	PU	Description	Item No.	PU
32 (1 1/4")	0	10 (13/32")	TEC 864-VS8-45U 1 1/4 WM A-SC	02910A-15	300	TEC 864-VS-45U 1 1/4 WM A-SC	04547A-15	300
33.5 (1 5/16")	0	10 (13/32")	TEC 864-VS8-45U 1 5/16 WM A-SC	02198A-15	300	TEC 864-VS-45U 1 5/16 WM A-SC	02176A-15	300
35 (1 3/8")	0	10 (13/32")	TEC 864-VS8-45U 1 3/8 WM A-SC	02782A-15	300	TEC 864-VS-45U 1 3/8 WM A-SC	04548A-15	300
38 (1 1/2")	0	10 (13/32")	TEC 864-VS8-45U 1 1/2 WM A-SC	02805A-15	300	TEC 864-VS-45U 1 1/2 WM A-SC	04549A-15	300



Side-mount - 42mm Drilling Pattern

Overlay	Door Clearance	Arm Clearance	Dowelled Hinge Cup (VS8)		
			Description	Item No.	PU
32 (1 1/4")	0	10 (13/32")	TEC 864-VS8-42U 1 1/4 SM A-SC	02838A-15	300



Wrap-around - 42mm Drilling Pattern

Overlay	Door Clearance	Arm Clearance	Dowelled Hinge Cup (VS8)		
			Description	Item No.	PU
32 (1 1/4")	0	10 (13/32")	TEC 864-VS8-42U 1 1/4 WM A-SC	02836A-15	300
35 (1 3/8")	0	10 (13/32")	TEC 864-VS8-42U 1 3/8 WM A-SC	02781A-15	300
38 (1 1/2")	0	10 (13/32")	TEC 864-VS8-42U 1 1/2 WM A-SC	02839A-15	300

Angle Reduction Clip

Description	Item No.	PU
85° Angle reduction clip	80125-42	100

- Reduces opening angle to 85°

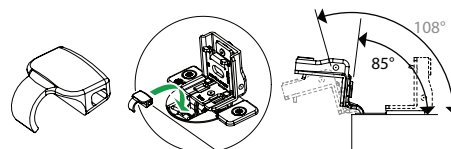

PU - Packaging unit

Dimensions - Door Closed	Minimum Reveal	Clearances - Door Open								
<p>4.9 (3/16") 2.5 (3/32") 20 (25/32") Max. Door Thickness 19 (3/4") Min. Door Thickness 11 (7/16")</p>	<p>#10 x 3/4" pan head screw 9.5 (3/8") Min. Reveal</p> <p>TEC 864 Minimum Reveal</p> <table border="1"> <tr> <td>Door Thickness</td> <td>16 (5/8")</td> <td>17.5 (1 1/16")</td> <td>19 (3/4")</td> </tr> <tr> <td>Minimum Reveal</td> <td>4.2 (5/32")</td> <td>5.4 (7/32")</td> <td>6.7 (1/4")</td> </tr> </table> <p>Based on door with square edge.</p>	Door Thickness	16 (5/8")	17.5 (1 1/16")	19 (3/4")	Minimum Reveal	4.2 (5/32")	5.4 (7/32")	6.7 (1/4")	<p>6.5 (1/4") Arm Clearance 108° Max. Door Thickness 19 (3/4")</p> <p>Arm and door clearances see page 12.</p>
Door Thickness	16 (5/8")	17.5 (1 1/16")	19 (3/4")							
Minimum Reveal	4.2 (5/32")	5.4 (7/32")	6.7 (1/4")							
Adjustments	Dimensions									

- Side Adjustment +/-1.5mm (1/16")
Rotate cam adjustment screw.
- Height Adjustment +/-2mm (3/32")
Loosen screw, align door, tighten screw.
- Depth Adjustment + 3mm (1/8")
Rotate cam screw.
- Soft-close Tension..... Light, Medium, and Strong setting
See page 9 for complete adjustment explanation

Mounting Screws
Hinge cup to door, #6 x 5/8" Flat head screw
Base plate to face frame, #10 x 3/4" Pan head screw

Overall Dimensions

Base Plates	Drilling Pattern	
<p>Wrap-around Base Plate</p> <p>Side-mount Base Plate</p>	<p>42mm drilling pattern</p>	<p>45mm drilling pattern</p>

IMPORTANT
To determine the correct application, GRASS strongly recommends a trial mounting for all hinges and base plates.

TEC Soft-close

108° Opening Angle - Face-mount



- Available in Soft-close and Self-close
- Soft-close damper is pre-mounted in the hinge cup
- Adjustment switch on Soft-close to regulate closing action
- One piece hinge and base plate combination
- 2 dimensional adjustment
- 11mm (7/16") cup drilling depth
- Height adjustment at mounting screw
- For overlays 1 7/16" and greater
- 85° angle reduction clip available for Soft-close and Self-close
- Made in the USA



Face-mount - 45mm Drilling Pattern Soft-close

Overlay mm (inch)	Door Clearance mm (inch)	Arm Clearance mm (inch)	Dowelled Hinge Cup (VS8)			Screw-on Hinge Cup (VS)		
			Description	Item No.	PU	Description	Item No.	PU
37 (1 7/16")	0	0	TEC 863-VS8-45U 1 7/16 FM A-SC	02294A-15	300	TEC 863-VS-45U 1 7/16 FM A-SC	02295A-15	300



Face-mount - 45mm Drilling Pattern Self-close

Overlay mm (inch)	Door Clearance mm (inch)	Arm Clearance mm (inch)	Dowelled Hinge Cup (VS8)			Screw-on Hinge Cup (VS)		
			Description	Item No.	PU	Description	Item No.	PU
37 (1 7/16")	0	0	TEC 863-VS8-45U 1 7/16 FM	02283-15	300	TEC 863-VS-45U 1 7/16 FM	02284-15	300



Face-mount - 42mm Drilling Pattern Soft-close

Overlay mm (inch)	Door Clearance mm (inch)	Arm Clearance mm (inch)	Dowelled Hinge Cup (VS8)		
			Description	Item No.	PU
37 (1 7/16")	0	0	TEC 863-VS8-42U 1 7/16 FM A-SC	02293A-15	300



Angle Reduction Clip

Description	Item No.	PU
85° Angle reduction clip	80125-42	100

- Reduces opening angle to 85°

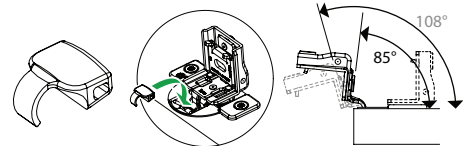

Face-mount - 42mm Drilling Pattern Self-close

Overlay mm (inch)	Door Clearance mm (inch)	Arm Clearance mm (inch)	Dowelled Hinge Cup (VS8)		
			Description	Item No.	PU
37 (1 7/16")	0	0	TEC 863-VS8-42U 1 7/16 FM	02282-15	300

PU - Packaging unit

Dimensions - Door Closed	Minimum Reveal	Clearances - Door Open								
	<p>TEC 863 Minimum Reveal</p> <table border="1"> <tr> <td>Door Thickness</td> <td>16 (5/8")</td> <td>17.5 (1 1/16")</td> <td>19 (3/4")</td> </tr> <tr> <td>Minimum Reveal</td> <td>4.2 (5/32")</td> <td>5.4 (7/32")</td> <td>6.7 (1/4")</td> </tr> </table> <p>Based on door with square edge.</p>	Door Thickness	16 (5/8")	17.5 (1 1/16")	19 (3/4")	Minimum Reveal	4.2 (5/32")	5.4 (7/32")	6.7 (1/4")	
Door Thickness	16 (5/8")	17.5 (1 1/16")	19 (3/4")							
Minimum Reveal	4.2 (5/32")	5.4 (7/32")	6.7 (1/4")							
<p>Adjustments</p>		<p>Dimensions</p>								

<p>1 Side Adjustment +/-1.5mm (1/16") Rotate cam adjustment screw.</p> <p>2 Height Adjustment +/-2mm (3/32") Loosen screws, align door, tighten screws.</p> <p>3 Soft-close Tension..... Light, Medium, and Strong setting See page 9 for complete adjustment explanation</p> <p>Mounting Screws Hinge cup to door, #6 x 5/8" Flat head screw Base plate to face frame, #6 x 5/8" Flat head screw</p> <p>Door Overlay = 37 (1 7/16") when base plate is flush inside edge of face frame.</p>		<p>Overall Dimensions</p>
--	--	----------------------------------

Drilling Pattern	
<p>42mm drilling pattern</p>	<p>45mm drilling pattern</p>

IMPORTANT
To determine the correct application, GRASS strongly recommends a trial mounting for all hinges and base plates.

TEC Self-close

108° Opening Angle - 1/4" to 1" Overlay



- One piece hinge and base plate combination
- 3 dimensional adjustment
- 11mm (7/16") cup drilling depth
- Front locating tabs position hinge on face frame
- Cam side adjustment
- Cam depth adjustment
- Height adjustment at mounting screw
- Works with current GRASS insertion machinery
- Made in the USA



Side-mount - 45 mm Drilling Pattern

Overlay	Door Clearance	Arm Clearance	Dowelled Hinge Cup (VS8)			Screw-on Hinge Cup (VS)		
			Description	Item No.	PU	Description	Item No.	PU
6 (1/4")	11 (7/16")	14.5 (9/16")	TEC 864-VS8-45U 1/4 SM	02851-15	300	TEC 864-VS-45U 1/4 SM	04386-15	300
12.7 (1/2")	3.5 (1/8")	11 (7/16")	TEC 864-VS8-45U 1/2 SM	02872-15	300	TEC 864-VS-45U 1/2 SM	04387-15	300
16 (5/8")	0.3 (1/32")	11 (7/16")	TEC 864-VS8-45U 5/8 SM	01864-15	300	-	-	-
19 (3/4")	0	11 (7/16")	TEC 864-VS8-45U 3/4 SM	02878-15	300	TEC 864-VS-45U 3/4 SM	04390-15	300
25 (1")	0	11 (7/16")	TEC 864-VS8-45U 1 SM	02885-15	300	TEC 864-VS-45U 1 SM	04395-15	300

Wrap-around - 45 mm Drilling Pattern

Overlay	Door Clearance	Arm Clearance	Dowelled Hinge Cup (VS8)			Screw-on Hinge Cup (VS)		
			Description	Item No.	PU	Description	Item No.	PU
6 (1/4")	11 (7/16")	14.5 (9/16")	TEC 864-VS8-45U 1/4 WM	02847-15	300	TEC 864-VS-45U 1/4 WM	04396-15	300
11 (7/16")	5.1 (13/64")	11 (7/16")	TEC 864-VS8-45U 7/16 WM	02904-15	300	-	-	-
12.7 (1/2")	3.5 (1/8")	11 (7/16")	TEC 864-VS8-45U 1/2 WM	02905-15	300	TEC 864-VS-45U 1/2 WM	04399-15	300
19 (3/4")	0	11 (7/16")	TEC 864-VS8-45U 3/4 WM	02907-15	300	TEC 864-VS-45U 3/4 WM	04400-15	300
25 (1")	0	11 (7/16")	TEC 864-VS8-45U 1 WM	02882-15	300	TEC 864-VS-45U 1 WM	04401-15	300

Side-mount - 42 mm Drilling Pattern

Overlay	Door Clearance	Arm Clearance	Dowelled Hinge Cup (VS8)		
			Description	Item No.	PU
12.7 (1/2")	3.5 (1/8")	11 (7/16")	TEC 864-VS8-42U 1/2 SM	02871-15	300
19 (3/4")	0	11 (7/16")	TEC 864-VS8-42U 3/4 SM	02877-15	300
25 (1")	0	11 (7/16")	TEC 864-VS8-42U 1 SM	02884-15	300

Wrap-around - 42 mm Drilling Pattern

Overlay	Door Clearance	Arm Clearance	Dowelled Hinge Cup (VS8)		
			Description	Item No.	PU
6 (1/4")	11 (7/16")	14.5 (9/16")	TEC 864-VS8-42U 1/4 WM	02846-15	300
12.7 (1/2")	3.5 (1/8")	11 (7/16")	TEC 864-VS8-42U 1/2 WM	02869-15	300
19 (3/4")	0	11 (7/16")	TEC 864-VS8-42U 3/4 WM	02873-15	300
25 (1")	0	11 (7/16")	TEC 864-VS8-42U 1 WM	02879-15	300

Angle Reduction Clip

Description	Item No.	PU
85° Angle reduction clip	80125-42	100

- Reduces opening angle to 85°

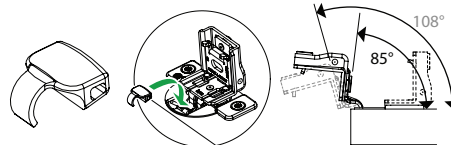

PU - Packaging unit

Dimensions - Door Closed	Minimum Reveal	Clearances - Door Open								
<p>4.9 (3/16") 2.5 (3/32") 20 (25/32") Max. Door Thickness 19 (3/4") Min. 11 (7/16")</p>	<p>#10 x 3/4" pan head screw 9.5 (3/8") Min. Reveal</p>	<p>8.5 (11/32") Arm Clearance Door Clearance 108° Maximum Door Thickness 19 (3/4")</p>								
<p>TEC 864 Minimum Reveal</p> <table border="1"> <tr> <td>Door Thickness</td> <td>16 (5/8")</td> <td>17.5 (11/16")</td> <td>19 (3/4")</td> </tr> <tr> <td>Minimum Reveal</td> <td>4.2 (5/32")</td> <td>5.4 (7/32")</td> <td>6.7 (1/4")</td> </tr> </table> <p>Based on door with square edge.</p>			Door Thickness	16 (5/8")	17.5 (11/16")	19 (3/4")	Minimum Reveal	4.2 (5/32")	5.4 (7/32")	6.7 (1/4")
Door Thickness	16 (5/8")	17.5 (11/16")	19 (3/4")							
Minimum Reveal	4.2 (5/32")	5.4 (7/32")	6.7 (1/4")							
<p>Arm and door clearances see page 14.</p>										

Adjustments	Dimensions
-------------	------------

- 1 Side Adjustment +/-1.5mm (1/16")
Rotate cam adjustment screw.
- 2 Height Adjustment +/-2mm (3/32")
Loosen screw, align door, tighten screw.
- 3 Depth Adjustment + 2.5mm (3/32"), -5mm (1/32")
Rotate cam screw.

Mounting Screws

Hinge cup to door, #6 x 5/8" Flat head screw
 Base plate to face frame, #10 x 3/4" Pan head screw

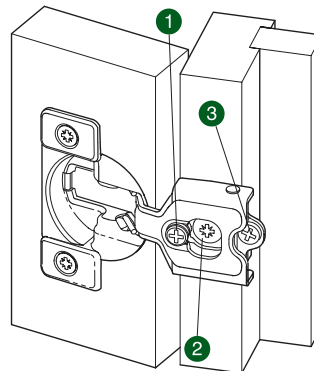

Overall Dimensions

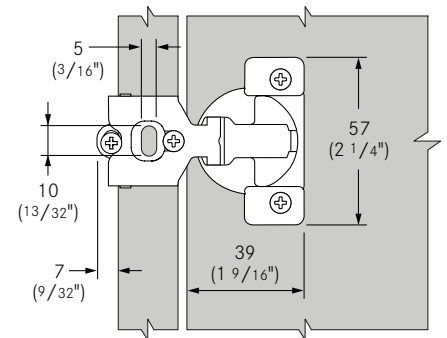

Base Plates	Drilling Pattern
-------------	------------------

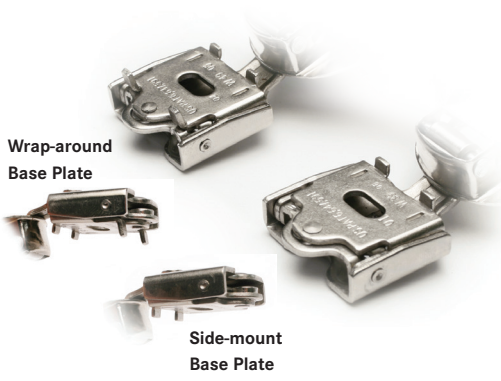

42mm drilling pattern

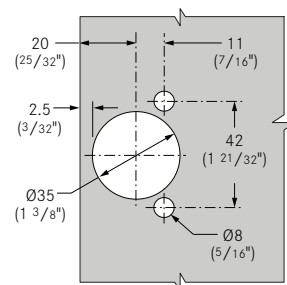

45mm drilling pattern

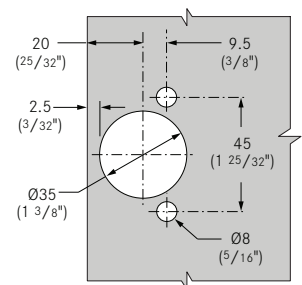

IMPORTANT

To determine the correct application, GRASS strongly recommends a trial mounting for all hinges and base plates.

TEC Self-close

108° Opening Angle - 1 1/4" to 1 1/2" Overlay



- One piece hinge and base plate combination
- 3 dimensional adjustment
- 11mm (7/16") cup drilling depth
- Front locating tabs position hinge on face frame
- Cam side adjustment
- Cam depth adjustment
- Height adjustment at mounting screw
- Works with current GRASS insertion machinery
- Made in the USA



Side-mount - 45mm Drilling Pattern

Overlay	Door Clearance	Arm Clearance	Dowelled Hinge Cup (VS8)			Screw-on Hinge Cup (VS)		
			Description	Item No.	PU	Description	Item No.	PU
32 (1 1/4")	0	10 (13/32")	TEC 864-VS8-45U 1 1/4 SM	02894-15	300	TEC 864-VS-45U 1 1/4 SM	04466-15	300
33.5 (1 5/16")	0	10 (13/32")	TEC 864-VS8-45U 1 5/16 SM	01094-15	300	-	-	-
35 (1 3/8")	0	10 (13/32")	TEC 864-VS8-45U 1 3/8 SM	02898-15	300	TEC 864-VS-45U 1 3/8 SM	04468-15	300
38 (1 1/2")	0	10 (13/32")	TEC 864-VS8-45U 1 1/2 SM	02903-15	300	TEC 864-VS-45U 1 1/2 SM	04469-15	300



Wrap-around - 45mm Drilling Pattern

Overlay	Door Clearance	Arm Clearance	Dowelled Hinge Cup (VS8)			Screw-on Hinge Cup (VS)		
			Description	Item No.	PU	Description	Item No.	PU
32 (1 1/4")	0	10 (13/32")	TEC 864-VS8-45U 1 1/4 WM	02887-15	300	TEC 864-VS-45U 1 1/4 WM	04493-15	300
33.5 (1 5/16")	0	10 (13/32")	TEC 864-VS8-45U 1 5/16 WM	01095-15	300	-	-	-
35 (1 3/8")	0	10 (13/32")	TEC 864-VS8-45U 1 3/8 WM	02896-15	300	TEC 864-VS-45U 1 3/8 WM	04498-15	300
38 (1 1/2")	0	10 (13/32")	TEC 864-VS8-45U 1 1/2 WM	02901-15	300	TEC 864-VS-45U 1 1/2 WM	04499-15	300



Side-mount - 42mm Drilling Pattern

Overlay	Door Clearance	Arm Clearance	Dowelled Hinge Cup (VS8)		
			Description	Item No.	PU
32 (1 1/4")	0	10 (13/32")	TEC 864-VS8-42U 1 1/4 SM	02889-15	300
35 (1 3/8")	0	10 (13/32")	TEC 864-VS8-42U 1 3/8 SM	02897-15	300
38 (1 1/2")	0	10 (13/32")	TEC 864-VS8-42U 1 1/2 SM	02902-15	300



Angle Reduction Clip

Description	Item No.	PU
85° Angle reduction clip	80125-42	100

- Reduces opening angle to 85°

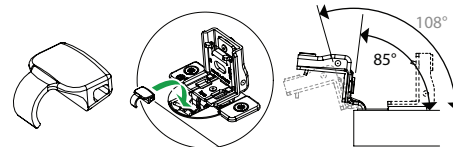

Wrap-around - 42mm Drilling Pattern

Overlay	Door Clearance	Arm Clearance	Dowelled Hinge Cup (VS8)		
			Description	Item No.	PU
32 (1 1/4")	0	10 (13/32")	TEC 864-VS8-42U 1 1/4 WM	02886-15	300
35 (1 3/8")	0	10 (13/32")	TEC 864-VS8-42U 1 3/8 WM	02895-15	300

PU - Packaging unit

Dimensions - Door Closed	Minimum Reveal	Clearances - Door Open								
<p>Overlay</p> <p>4.9 (3/16")</p> <p>2.5 (3/32")</p> <p>20 (25/32")</p> <p>Max. Door Thickness 19 (3/4")</p> <p>Min. Door Thickness 11 (7/16")</p>	<p>#10 x 3/4" pan head screw</p> <p>9.5 (3/8")</p> <p>Min. Reveal</p> <p>TEC 864 Minimum Reveal</p> <table border="1"> <tr> <td>Door Thickness</td> <td>16 (5/8")</td> <td>17.5 (11/16")</td> <td>19 (3/4")</td> </tr> <tr> <td>Minimum Reveal</td> <td>4.2 (5/32")</td> <td>5.4 (7/32")</td> <td>6.7 (1/4")</td> </tr> </table> <p>Based on door with square edge.</p>	Door Thickness	16 (5/8")	17.5 (11/16")	19 (3/4")	Minimum Reveal	4.2 (5/32")	5.4 (7/32")	6.7 (1/4")	<p>6.5 (1/4")</p> <p>Arm Clearance</p> <p>108°</p> <p>Max. Door Thickness 19 (3/4")</p> <p>Arm and door clearances see page 16.</p>
Door Thickness	16 (5/8")	17.5 (11/16")	19 (3/4")							
Minimum Reveal	4.2 (5/32")	5.4 (7/32")	6.7 (1/4")							
Adjustments	Dimensions									

- 1 Side Adjustment +/-1.5mm (1/16")
Rotate cam adjustment screw.
- 2 Height Adjustment +/-2mm (3/32")
Loosen screw, align door, tighten screw.
- 3 Depth Adjustment + 3mm (1/8")
Rotate cam screw.

Mounting Screws

Hinge cup to door, #6 x 5/8" Flat head screw
Base plate to face frame, #10 x 3/4" Pan head screw

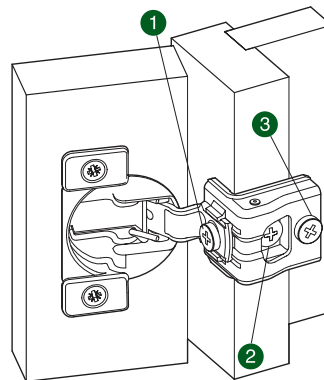

Overall Dimensions

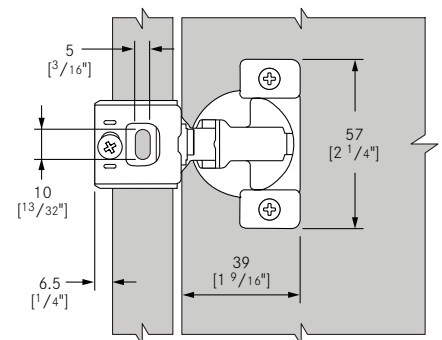

Base Plates	Drilling Pattern
-------------	------------------

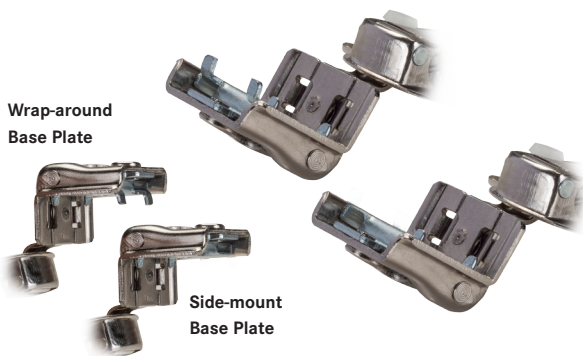

IMPORTANT

To determine the correct application, GRASS strongly recommends a trial mounting for all hinges and base plates.

42mm drilling pattern

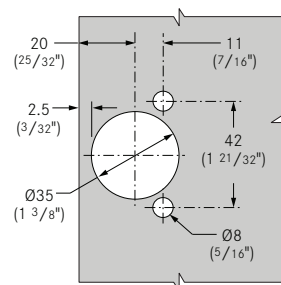

45mm drilling pattern

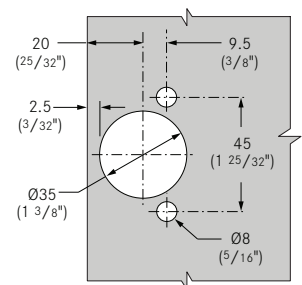

TEC 861 Self-close

108° Opening Angle



- One piece hinge and base plate combination
- 11mm (7/16") cup drilling depth
- Front locating tabs position hinge on face frame
- Works on door thicknesses from 13mm (1/2") to 19mm (3/4")
- Works with current GRASS machinery
- 85° angle reduction clip available
- Made in the USA



Wrap-around - 45mm Drilling Pattern

Overlay	Door Clearance	Arm Clearance	Dowelled Hinge Cup (VS8)		
mm (inch)	mm (inch)	mm (inch)	Description	Item No.	PU
11 (7/16")	5 (3/16")	9.5 (3/8")	TEC 861-VS8-45U 7/16 WM	04728-16	400
12 (1/2")	3 (1/8")	7 (9/32")	TEC 861-VS8-45U 1/2 WM	04780-16	400
14 (9/16")	2.5 (3/32")	7 (9/32")	TEC 861-VS8-45U 9/16 WM	04729-16	400



Wrap-around - 42mm Drilling Pattern

Overlay	Door Clearance	Arm Clearance	Dowelled Hinge Cup (VS8)		
mm (inch)	mm (inch)	mm (inch)	Description	Item No.	PU
12 (1/2")	3 (1/8")	7 (9/32")	TEC 861-VS8-42U 1/2 WM	04679-16	400
14 (9/16")	2.5 (3/32")	7 (9/32")	TEC 861-VS8-42U 9/16 WM	04700-16	400



Side-mount - 42mm Drilling Pattern

Overlay	Door Clearance	Arm Clearance	Dowelled Hinge Cup (VS8)		
mm (inch)	mm (inch)	mm (inch)	Description	Item No.	PU
11 (7/16")	5 (3/16")	9.5 (3/8")	TEC 861-VS8-42U 7/16 SM	04616-16	400

Angle Reduction Clip

Description	Item No.	PU
85° Angle reduction clip	80125-42	100

- Reduces opening angle to 85°

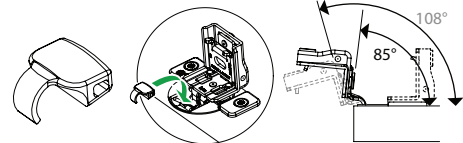

Side Adjustment Spacer

Description	Item No.	PU
1.5 mm (1/16") slotted spacer	00047-42	100



PU - Packaging unit

Dimensions - Door Closed	Minimum Reveal	Clearances - Door Open								
<p>4.9 (3/16") 2.5 (3/32") Max. Door Thickness 19 (3/4") Min. 11 (7/16") 20 (25/32")</p>	<p>#10 x 3/4" pan head screw 9.5 (3/8") Min. Reveal</p> <p>TEC 861 Minimum Reveal</p> <table border="1"> <tr> <td>Door Thickness</td> <td>16 (5/8")</td> <td>17.5 (11/16")</td> <td>19 (3/4")</td> </tr> <tr> <td>Minimum Reveal</td> <td>4.2 (5/32")</td> <td>5.4 (7/32")</td> <td>6.7 (1/4")</td> </tr> </table> <p>Based on door with square edge.</p>	Door Thickness	16 (5/8")	17.5 (11/16")	19 (3/4")	Minimum Reveal	4.2 (5/32")	5.4 (7/32")	6.7 (1/4")	<p>Arm Clearance Door Clearance 108° Maximum Door Thickness 19 (3/4")</p> <p>Arm and door clearances see page 20.</p>
Door Thickness	16 (5/8")	17.5 (11/16")	19 (3/4")							
Minimum Reveal	4.2 (5/32")	5.4 (7/32")	6.7 (1/4")							

Adjustments	Dimensions
-------------	------------

- Side Adjustment Decreasing overlay achieved with use of 1.5mm (1/16") spacer.
- Height Adjustment +/-2mm (3/32")
Loosen screw, align door, tighten screw.

Mounting Screws

Hinge cup to door, #6 x 5/8" Flat head screw
 Base plate to face frame, #10 x 3/4" Pan head screw

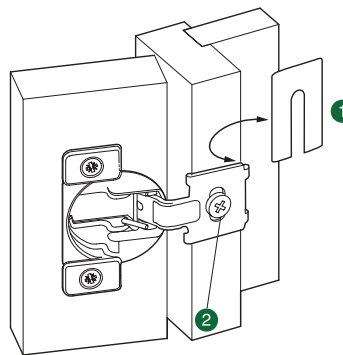

Overall Dimensions

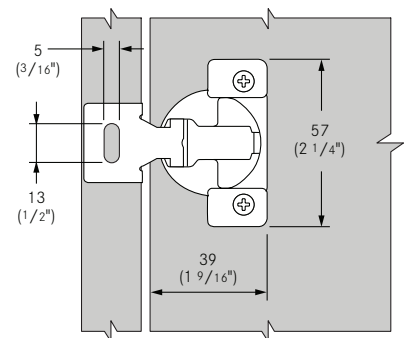

Base Plates	Drilling Pattern
-------------	------------------

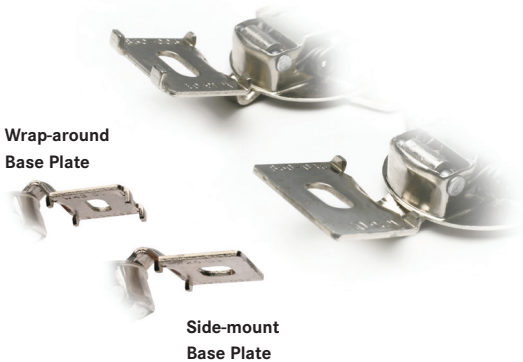

IMPORTANT

To determine the correct application, GRASS strongly recommends a trial mounting for all hinges and base plates.

42mm drilling pattern

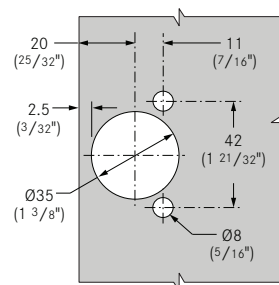

45mm drilling pattern

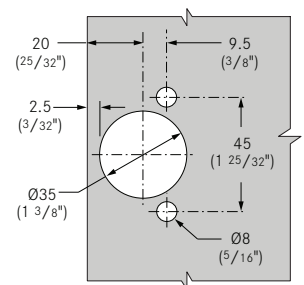

TEC 861 for MDF Frame Material

108° Opening Angle



- Patented wrap-around base plate prevents splitting of frame material
- One piece hinge and base plate combination
- 11mm (7/16") cup drilling depth
- Front locating tabs position hinge on face frame
- Works on door thicknesses from 13mm (1/2") to 19mm (3/4")
- Works with current GRASS machinery
- 85° angle reduction clip available
- Made in the USA



Wrap-around - 42mm Drilling Pattern

Frame Thickness	Overlay	Door Clearance	Arm Clearance	Dowelled Hinge Cup (VS8)		
mm (inch)	mm (inch)	mm (inch)	mm (inch)	Description	Item No.	PU
12 (1/2")	12.5 (1/2")	3 (1/8")	7.5 (9/32")	TEC 861-VS8-42U 1/2 FT	04742-14	250
16 (5/8")	12.5 (1/2")	3 (1/8")	7.5 (9/32")	TEC 861-VS8-42U 5/8 FT	04743-14	250
19 (3/4")	12.5 (1/2")	3 (1/8")	7.5 (9/32")	TEC 861-VS8-42U 3/4 FT	04744-14	250

Spacer and screws

	Description	Item No.	PU
Spacer	1.5 mm (1/16") slotted for MDF 861, clear	00209-42	100
Screw	No. 8 x 3/4" Round head, self drilling, zinc	81018-43	500
Screw	No. 8 x 5/8" Round head, truss quad, self drilling,	81017-43	500

1.5 (1/16")
Spacer



Angle Reduction Clip

Description	Item No.	PU
85° Angle reduction clip	80125-42	100

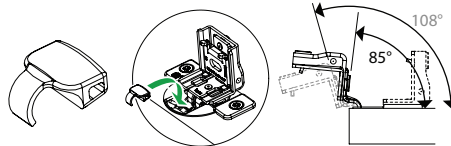

PU - Packaging unit

Dimensions - Door Closed	Minimum Reveal	Clearances - Door Open								
	<p>TEC 861 Minimum Reveal</p> <table border="1"> <tr> <td>Door Thickness</td> <td>16 (5/8")</td> <td>17.5 (11/16")</td> <td>19 (3/4")</td> </tr> <tr> <td>Minimum Reveal</td> <td>4.2 (5/32")</td> <td>5.4 (7/32")</td> <td>6.7 (1/4")</td> </tr> </table> <p>Based on door with square edge.</p>	Door Thickness	16 (5/8")	17.5 (11/16")	19 (3/4")	Minimum Reveal	4.2 (5/32")	5.4 (7/32")	6.7 (1/4")	<p>Arm and door clearances see page 22.</p>
Door Thickness	16 (5/8")	17.5 (11/16")	19 (3/4")							
Minimum Reveal	4.2 (5/32")	5.4 (7/32")	6.7 (1/4")							
Adjustments	Dimensions									

- Side Adjustment Decreasing overlay achieved with use of 1.5mm (1/16") spacer.
- Height Adjustment +/-2mm (3/32")
Loosen screws, align door, tighten screws.

Mounting Screws
 Hinge cup to door, #6 x 5/8" Flat head screw
 Base plate to face frame,
 #8 x 3/4" Round head, self drilling screw or
 #8 x 5/8" Round head, self drilling screw

Overall Dimensions

Drilling Pattern

42mm drilling pattern

IMPORTANT
 To determine the correct application, GRASS strongly recommends a trial mounting for all hinges and base plates.

TEC 872

110° Opening Angle



- 1/2" overlay achievable on profile door
- Available in 45mm boring pattern
- 3-dimensional hinge
- All metal construction, nickel finish
- Height adjustment in elongated screw hole
- Minimal gap between the door and frame
- Minimal protrusion into cabinet
- Hinge and base plate must be ordered separately



TEC 872 Opening Angle 110°

Dowelled Hinge Cup (VS8)			Screw-on Hinge Cup (VS)		
Description	Item No.	PU	Description	Item No.	PU
TEC 872-VS8-45	43729-17	500	TEC 872-VS-45	43727-17	500

Side-mount Base Plates

Plate Height	Description	Item No.	PU
00	872-18 Side-mount	43730-43	500
04	872-22 Side-mount	43731-43	500

PU - Packaging unit

Dimensions - Door Closed

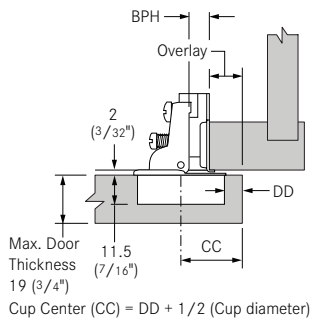

Drilling Distance (DD)

	3	4	5	6	7
19				0	
18				0	
17			0		
16		0			
15	0				4
14				4	
13			4		
12		4			
11	4				

Door Overlay max.

Base Plate Height (BPH)

Minimum Reveal

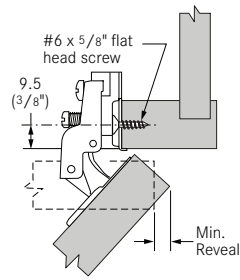

TEC 872 Minimum Reveal

Door Thickness	16 (5/8")	17.5 (11/16")	19 (3/4")
Minimum Reveal	1 (3/64")	1 (3/64")	1 (3/64")

Based on door with square edge.

Clearances - Door Open

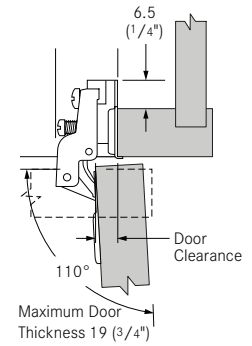

Adjustments

- Side Adjustment +/-2mm (3/32")
Rotate cam adjustment screw.
- Height Adjustment +/-2mm (3/32")
Loosen screws, align door, tighten screws.
- Depth Adjustment +/-2mm (3/32")
Loosen screw, align door, tighten screw.

Mounting Screws

Hinge cup to door, #6 x 5/8" Flat head screw
Base plate to face frame, #6 x 5/8" Flat head screw
or #6 x 3/4" Flat head screw

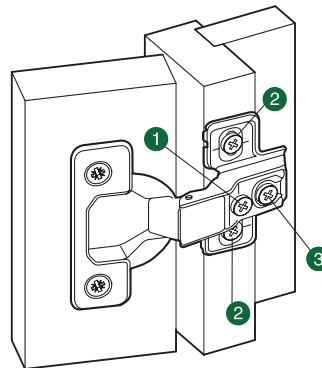

Dimensions

Overall Dimensions

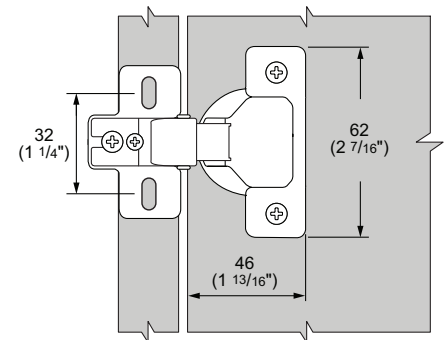

Drilling Pattern

45mm drilling pattern

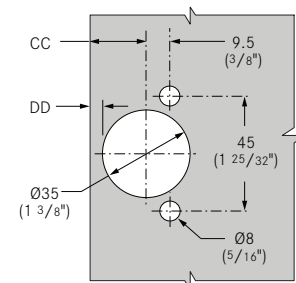

IMPORTANT

To determine the correct application, GRASS strongly recommends a trial mounting for all hinges and base plates.

Machinery

GRASS PRO1 drilling and insertion machine for 45mm boring pattern

GRASS PRO1



- Depth stop can be adjusted to material thickness
- Functional design
- Easy, fast and efficient operation
- Easy maintenance
- 45mm boring pattern

Description	Item No.	PU
220v single phase pneumatic	94559-01	1
220v three phase pneumatic	94560-01	1
110v single phase pneumatic	94561-01	1

GRASS PRO1 Features

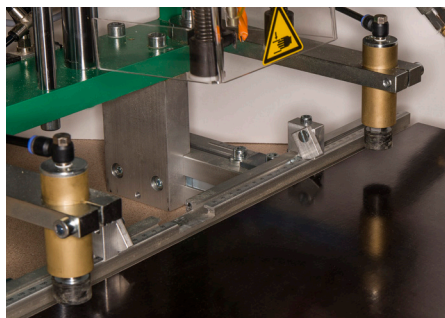

Adjustable hold-down devices

Adjustable hold-down devices are suitable for a wide range of material thicknesses. Holds door firmly in place for drilling and insertion and features manual release.

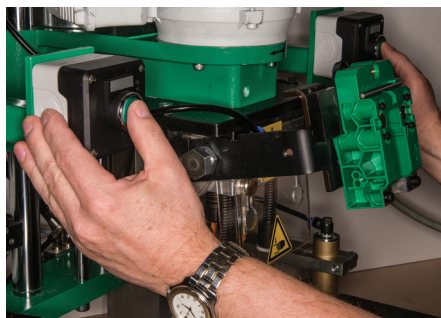

Pneumatic controls

Two-hand start button controls for safe drilling and insertion functions.



Quick change chucks

Easy drill bit removal and insertion using quick change chucks.

PU - Packaging unit

Drill Bits

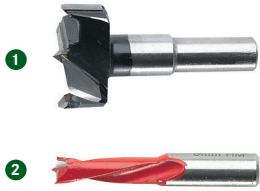

Description	Item No.	PU
① 35mm diameter, RH	00077-01	1
② 8mm diameter, LH	00160-01	1
Bit set for hinge drilling		
1 x 35mm/RH, 2 x 8mm/LH	00213-01	1

Fence Stops

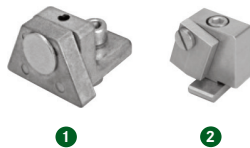

Description	Item No.	PU
① Additional fence stop	949.200.21.0000	1
② Universal fence stop	949.200.21.0100	1

Insertion Dies

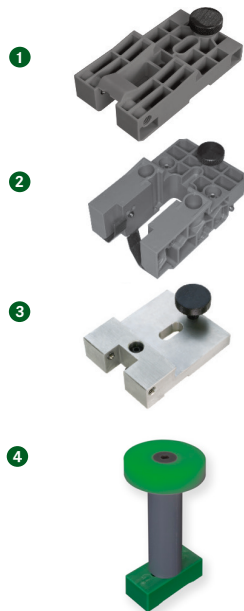

Description	Item No.	PU
① Tiomos 110°/120°	F146101310201	1
② Universal Die for Tiomos 110°/120°/100°	F146101308201	1
③ TEC Die for all cup styles	92617	1
④ TEC Hand insertion tool	03987-01	1

Extension Fence



Description	Item No.	PU
Extension fence 400mm to 1650mm	88612-01	1

Assembly Hardware

Shelf Supports



Description	Item No.	PU
Plastic, clear, with steel pin	499.582.50.0050	5000
Metal spoon, nickel plated	499.582.50.2050	2000
Shelf support 7006/9.5, nickel	517.206.64.1015	2500
Shelf support 7035, nickel	517.206.61.0015	2500
H-802 plastic, square, clear	00036-43	500

Bumper Pads

AIRSOFT Bumper Pads, Plastic, Round



Description	Item No.	PU
AirSoft Bumper pad, 2.5mm, clear	63480-99	480
AirSoft Bumper pad, 2.5mm, clear	63482-30	5000
AirSoft Bumper pad, 5mm, clear	63481-43	500
AirSoft Bumper pad, 5mm, clear	63483-30	5000

Self-adhesive Bumper Pads



Description	Item No.	PU
Self-adhesive bumper pad, clear, 7mm	630.000.03.0750	1088
Self-adhesive bumper pad, clear, 10mm	630.000.03.1050	1050
Self-adhesive bumper pad, clear, 12mm	630.000.02.1250	5000

Bumper Pads



Description	Item No.	PU
Bumper pad, round, clear, 3mm	31002-43	500
Bumper pad, round, clear, 1.5mm	31004-43	500

Bumper Pads

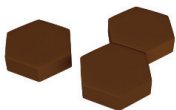

Description	Item No.	PU
Bumper pad, hexagonal, butterscotch, 3mm	00464-43	500

Door Stop



Description	Item No.	PU
H-950 door stop, clear	00068-43	500

PU - Packaging unit

Cover Caps

Hole covers for 35mm cup drillings



Description	Item No.	PU
35mm cover cap, white	22227-42	100
35mm cover cap, almond	22228-42	100
35mm cover cap, brown	22229-42	100

Angle Reduction Clip

Reduces opening angle to 85°

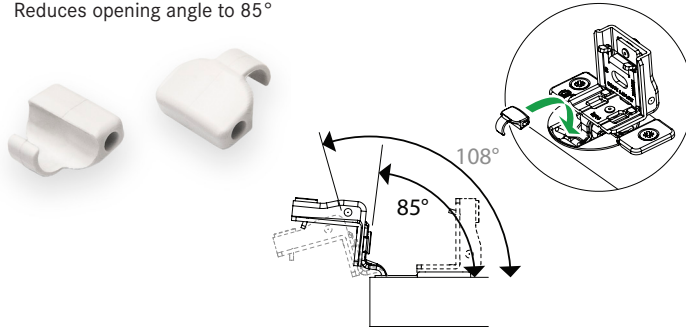

Description	Item No.	PU
85° Angle reduction clip	80125-42	100

Spacers

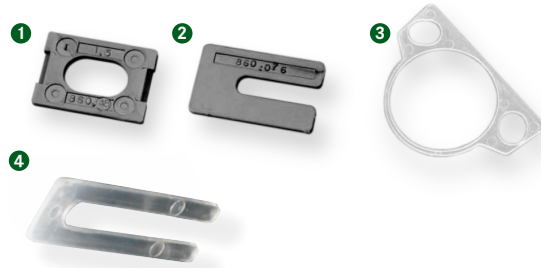

Description	Item No.	PU
1 860-048 1.5mm (1/16") thick, without locating pins	00264-42	100
2 860-076 1.5mm (1/16") thick, slotted	00047-42	100
3 1.5mm (1/16") thick, hinge cup spacer	00284-42	100
4 1.5mm (1/16") thick, slotted for MDF, clear	00209-42	100

Screws

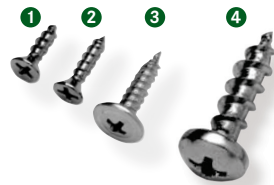

Description	Item No.	PU
1 No. 6 x 1/2" Flat head, nickel	81014-43	500
2 No. 6 x 5/8" Flat head, nickel	81001-43	500
3 No. 8 x 3/4" Round head, self-drilling, zinc	81018-43	500
4 No. 10 x 3/4" Pan head, nickel	81007-43	500
5 No. 8 x 5/8" Round head, truss quad, self-drilling, zinc	81017-43	500



GRASS America Inc.
1202 NC Highway 66 South
Kernersville, NC 27284

Phone: 1-800-334-3512
Fax: 1-800-525-8406

Website: www.grassusa.com
E-mail: info@grassusa.com

GRASS Canada Inc.
10 Newgale Gate, Unit 7
Toronto, ON M1X 1C5

Phone: 1-800-461-4975
Fax: 1-416-335-5907

Internet: www.grasscanada.com
E-Mail: info@grasscanada.com



www.grassusa.com