



ELITE PLUS



G* GRASS®

ELITE PLUS SLIDE SYSTEM

Undermount drawer technology with superior running performance and smooth closing action





Bringing together the advances and experience of undermount technology with a precision roller carriage.





Solid, superior and designed for uncompromised performance

The innovative Elite Plus drawer slide draws attention to the beauty of your cabinetry and leaves the mounted hardware completely out of sight. The Elite Plus brings together the advances of undermount technology with a precision roller carriage and features a new liquid damper technology that is designed for a smoother closing transition.

Offered in a full range of lengths for frameless and face frame construction, the Elite Plus features a full drawer extension for maximum use of interior space. It is a proven undermount slide with an ample load capacity of 75 lb that meets and exceeds ANSI/BHMA Grade 1 testing standards. Year after year, Elite Plus enables drawers to function quietly and flawlessly with the quality construction and Grass standard of excellence you have come to expect.

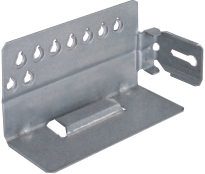

Table of Content

	Description	Adjustment	Page
	Features & Benefits		4
	Elite Plus 16 <ul style="list-style-type: none"> • Integrated Soft-close • Full extension • For 16mm (5/8") material 	<ul style="list-style-type: none"> • Height adjustment (2.5mm) • Side tolerance, left side (max. $\pm 1.5\text{mm}$) 	6
	Elite Plus 19 <ul style="list-style-type: none"> • Integrated Soft-close • Full extension • For 19mm (3/4") material 	<ul style="list-style-type: none"> • Height adjustment (2.5mm) • Side tolerance, left side (max. $\pm 1.5\text{mm}$) 	8
	V-notch Brackets <ul style="list-style-type: none"> • V-notch Brackets, 19mm 		10
	Accessories <ul style="list-style-type: none"> • Drilling Template • Screws 		10

Weight Capacities per Pair of Slides

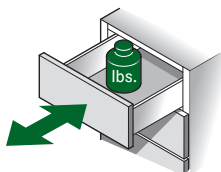

Elite Plus: 75 lb dynamic load rating; 100 lb static load rating

Elite Plus meets and exceeds the minimum requirements of ANSI/BHMA 156.1 standard, Grade 1

Features and Benefits

Elite Plus

Features



- Slide is concealed to give full view of finely crafted drawers
- Liquid damper softly glides drawers to a stop
- Weight capacity: 75 lb dynamic, 100 lb static
- Available for 16mm (5/8") and 19mm (3/4") drawer side thickness
- For frameless and face frame construction
- Zinc plated roll form steel composition
- Precision smooth running synthetic roller carriages
- Self-latching front locking devices have easy release levers for drawer removal and integrated height adjustment of 2.5mm (3/32")
- Meets and exceeds ANSI/BHMA 156.9, Grade 1

Multiple cleats

For secure front locking.

Depth Adjustment

4mm (5/32") allows perfect alignment for the drawer front.



Minimal opening force

Superb soft-closing action.



Front locking device

with height adjustment
+2.5mm (3/32")

The front locking device securely connects the drawer to the slide.



Flanged front locking device

with height adjustment
+2.5mm (3/32")

The front locking device securely connects the drawer to the slide.

Features

- Soft-closing mechanism fully enclosed
- Precision German made liquid damper
- Interchangeable with Maxcess full access and Dynapro full extension
- Uses same front locking devices as Maxcess
- Patented technology

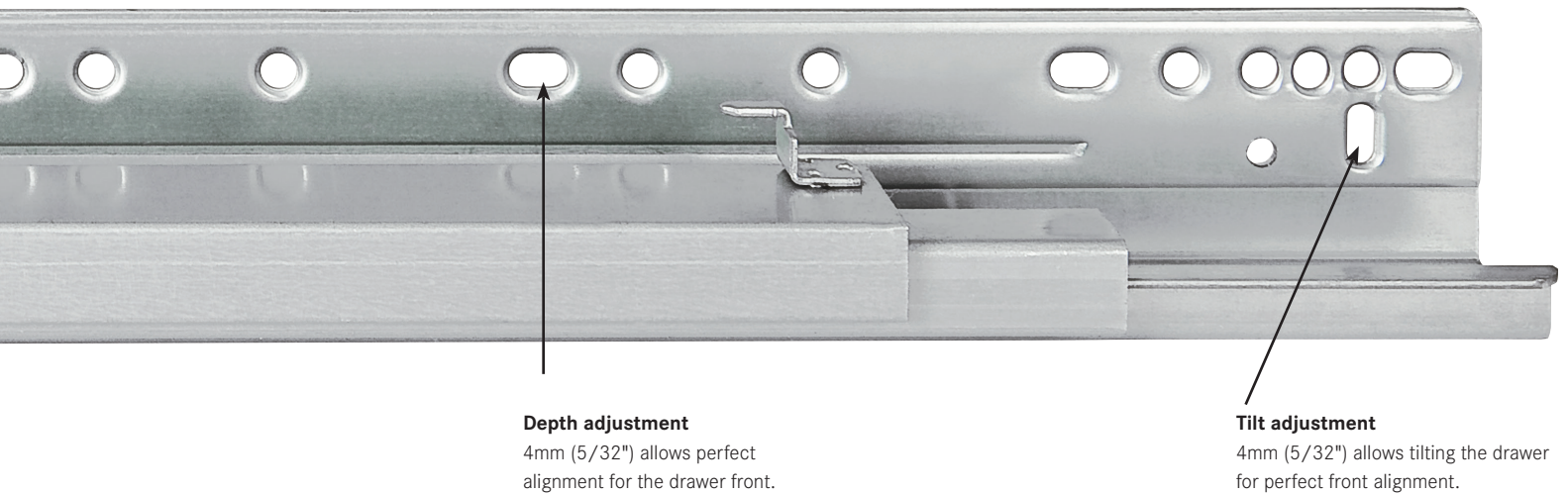
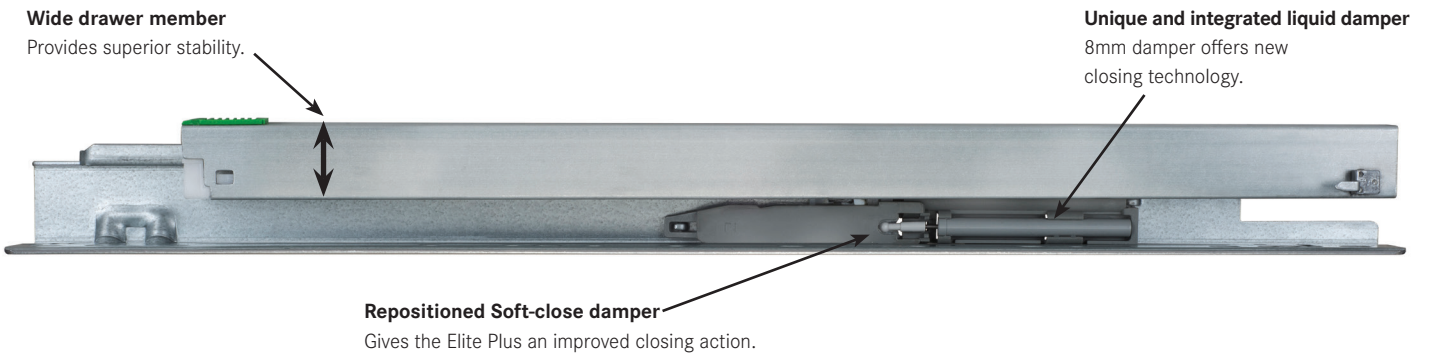

Self-aligning rear mount bracket
Brackets self-align the drawer when cabinets are out of square, $\pm 2\text{mm}$ (3/32") adjustment range.

For additional rear mount brackets see page 10.

Elite Plus 16

Full Extension Slide for 16mm (5/8") drawer material



- Slide is concealed to give a full view of finely crafted drawers
- Zinc plated, roll formed steel components
- Precision, smooth-running synthetic roller carriages
- Liquid damper softly glides drawers to a stop
- Self-latching front locking devices have comfortable release levers for drawer removal and installation
- Front locking device with height adjustment 2.5mm (3/32")
- Positive tracked right side, ± 1.5mm (1/16") side tolerance on left side
- Self-closing mechanism engages 30mm (1 1/4") before closed position
- Weight capacity: 75 lb dynamic, 100 lb static
- Meets and exceeds ANSI/BHMA 156.9, Grade 1

Elite Plus 16



Drawer Length	Nominal length	Min Installation Depth	Max Installation Depth	Item No.	PU
240 (9 7/16")	250 (9 27/32")	259 (10 3/16")	296 (11 5/8")	13132-03	5
305 (12")	317 (12 15/32")	329 (12 15/16")	363 (14 5/16")	13133-03	5
381 (15")	394 (15 1/2")	407 (16")	440 (17 5/16")	13363-03	5
457 (18")	470 (18 1/2")	479 (18 7/8")	516 (20 5/16")	13364-03	5
533 (21")	550 (21 21/32")	562 (22 1/8")	596 (23 7/16")	13365-03	5
381 (15")	394 (15 1/2")	407 (16")	440 (17 5/16")	13363-12	200
457 (18")	470 (18 1/2")	479 (18 7/8")	516 (20 5/16")	13364-12	200
533 (21")	550 (21 21/32")	562 (22 1/8")	596 (23 7/16")	13365-12	200

*For frameless applications, deduct 1.5mm (1/16") for minimum installation depth

Front Locking Devices and Rear Mounting Bracket

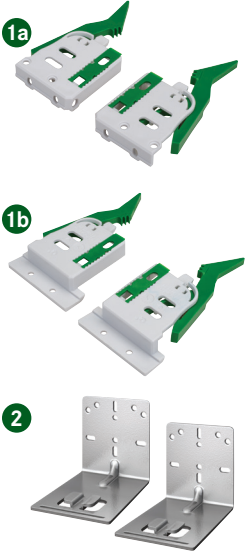

Description	Item No.	PU
(Please order separately)		
1a 7523 Front locking device, universal, kit*	02500-03	5
7523 Front locking device, universal, left	02498-12	200
7523 Front locking device, universal, right	02499-12	200
1b 7523 Flanged front locking device, universal, kit*	02497-12	200
7523 Flanged front locking device, universal, left	02495-12	200
7523 Flanged front locking device, universal, right	02496-12	200
2 7523 Universal rear mount bracket**	7950.VE20	20
7523 Universal rear mount bracket**	7950.VE300	300

*Kit: Left/Right locking device, (4) #6 x 1/2" flat head Phillips screws, **Plug-in brackets available on page 10

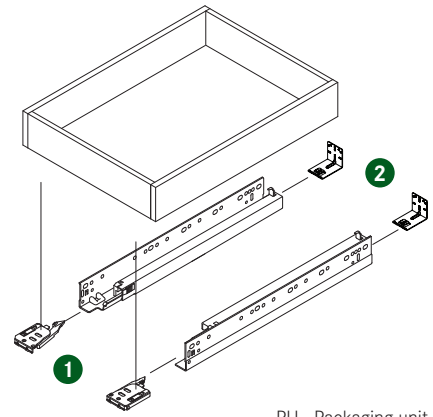

PU - Packaging unit

Drawer Installation Dimensions

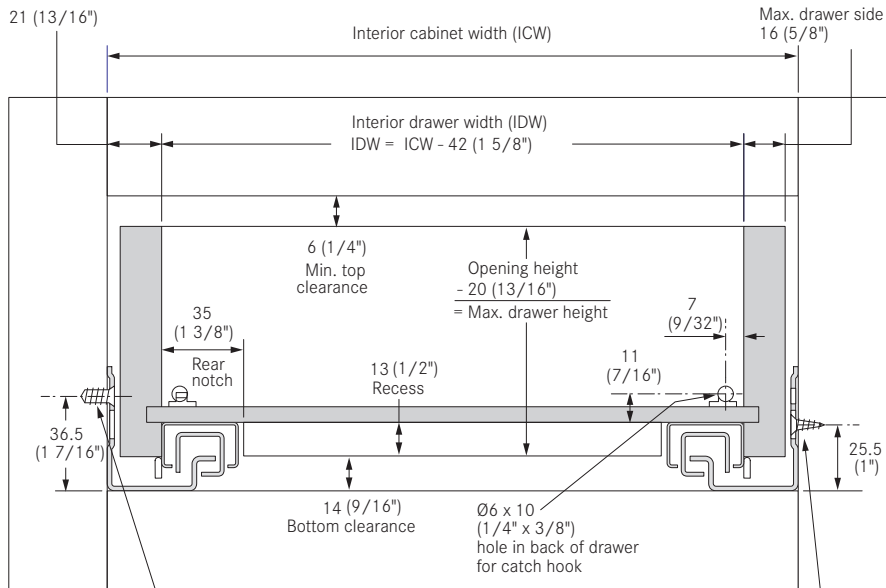

Euro screw Ø5 x 13mm or #7 x 5/8" flat head wood screw location on panel cabinets

#7 wood screw location at face frame

Rear Bracket Position/Drawer Measurements

Rear Bracket for Face Frame

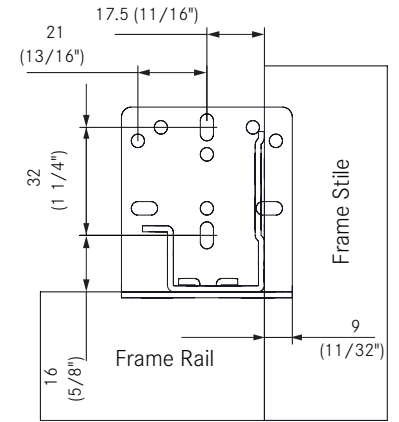

For face frame applications only. Use minimum of 3 screws per bracket, #6 x 1/2" truss head screws.

Drawer Measurements

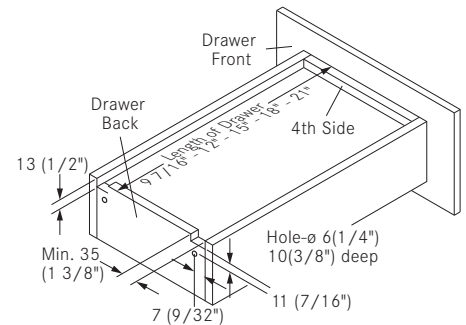

Cabinet Member Boring Specifications

Face Frame

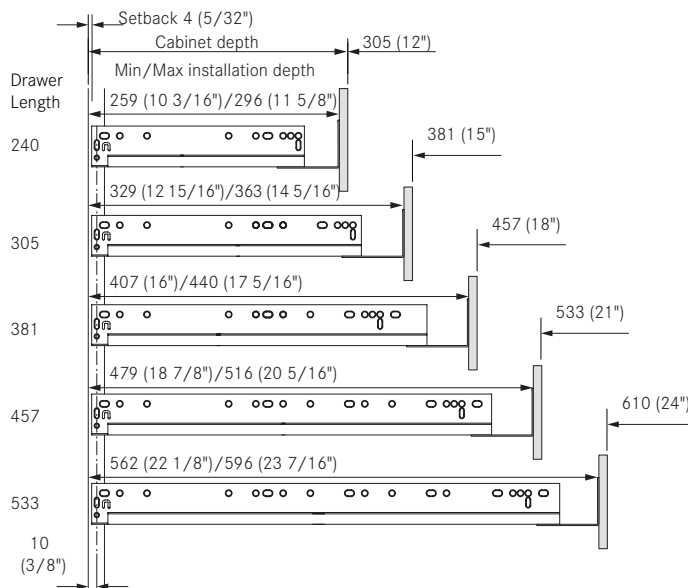

Frameless

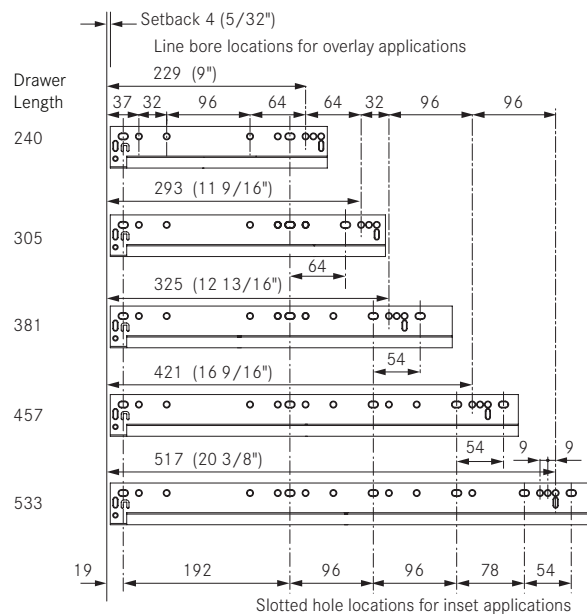

Elite Plus 19

Full Extension Slide for 19mm (3/4") drawer material



- Slide is concealed to give a full view of finely crafted drawers
- Zinc plated, roll formed steel components
- Precision, smooth-running synthetic roller carriages
- Liquid damper softly glides drawers to a stop
- Self-latching front locking devices have comfortable release levers for drawer removal and installation
- Front locking device with height adjustment 2.5mm (3/32")
- Positive tracked right side, ± 1.5mm (1/16") side tolerance on left side
- Self-closing mechanism engages 30mm (1 1/4") before closed position
- Weight capacity: 75 lb dynamic, 100 lb static
- Meets and exceeds ANSI/BHMA 156.9, Grade 1

Elite Plus 19



Drawer Length	Nominal length	Min Installation Depth	Max Installation Depth	Item No.	PU
240 (9 7/16")	250 (9 27/32")	259 (10 3/16")	296 (11 5/8")	13183-03	5
305 (12")	317 (12 15/32")	329 (12 15/16")	363 (14 5/16")	13184-03	5
381 (15")	394 (15 1/2")	407 (16")	440 (17 5/16")	13185-03	5
457 (18")	470 (18 1/2")	479 (18 7/8")	516 (20 5/16")	13186-03	5
533 (21")	550 (21 21/32")	562 (22 1/8")	596 (23 7/16")	13139-03	5
457 (18")	470 (18 1/2")	479 (18 7/8")	516 (20 5/16")	13186-12	200
533 (21")	550 (21 21/32")	562 (22 1/8")	596 (23 7/16")	13139-12	200

*For frameless applications, deduct 1.5mm (1/16") for minimum installation depth

Front Locking Devices and Rear Mounting Bracket

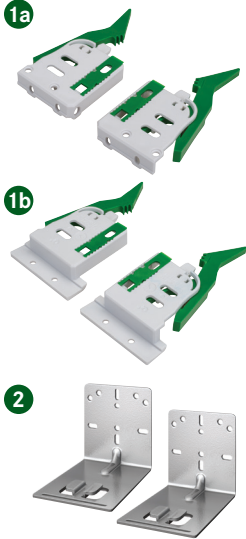

Description	Item No.	PU
(Please order separately)		
1a 7523 Front locking device, universal, kit*	02500-03	5
7523 Front locking device, universal, left	02498-12	200
7523 Front locking device, universal, right	02499-12	200
1b 7523 Flanged front locking device, universal, kit*	02497-12	200
7523 Flanged front locking device, universal, left	02495-12	200
7523 Flanged front locking device, universal, right	02496-12	200
2 7523 Universal rear mount bracket**	7950.VE20	20
7523 Universal rear mount bracket**	7950.VE300	300

*Kit: Left/Right locking device, (4) #6 x 1/2" flat head Phillips screws, **Plug-in brackets available on page 10

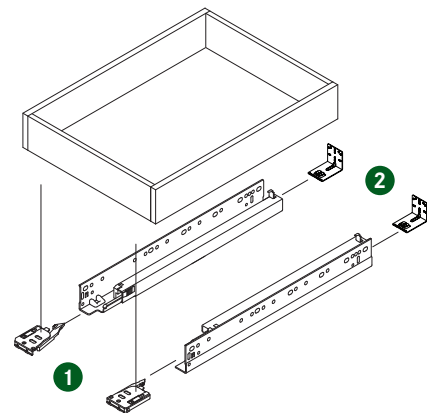

PU - Packaging unit

Drawer Installation Dimensions

Rear Bracket Position/Drawer Measurements

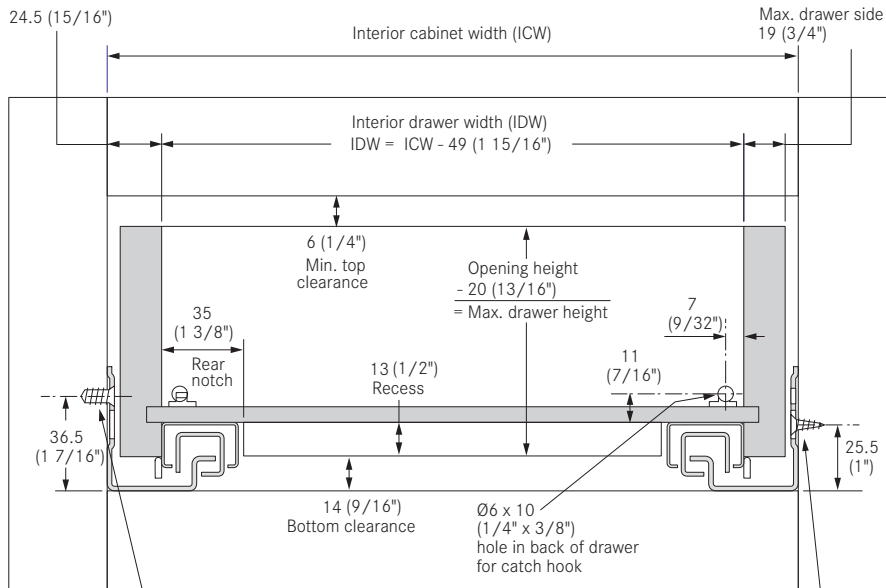

Euro screw Ø5 x 13mm or #7 x 5/8" flat head wood screw location on panel cabinets

#7 wood screw location at face frame

Rear Bracket for Face Frame

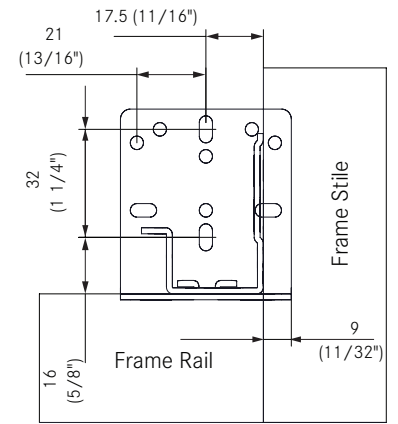

For face frame applications only. Use minimum of 3 screws per bracket, #6 x 1/2" truss head screws.

Drawer Measurements

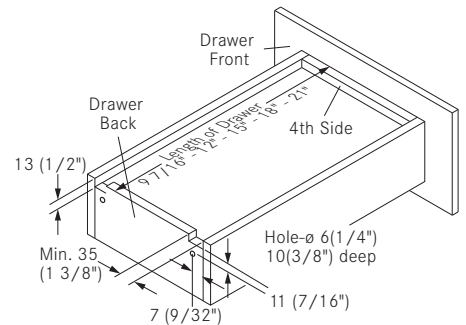

Cabinet Member Boring Specifications

Face Frame

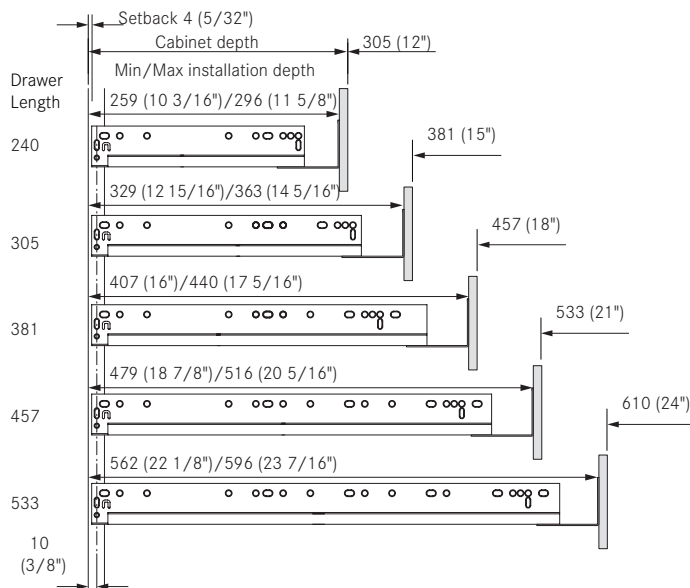

Frameless

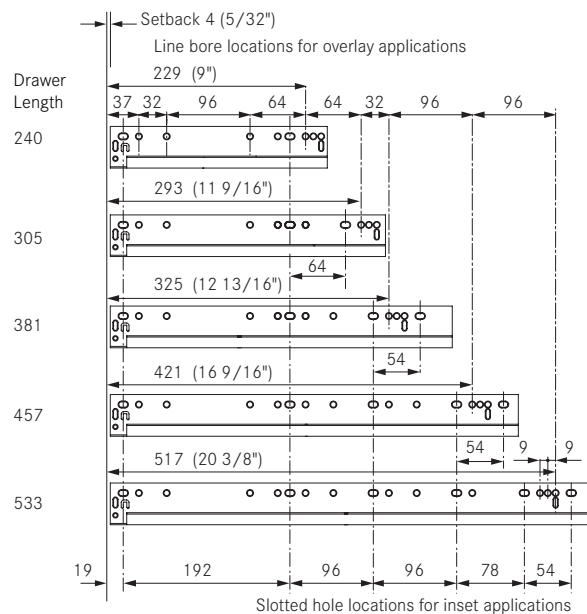

Accessories

Elite Plus

V-notch Rear Mounting Brackets, 19mm

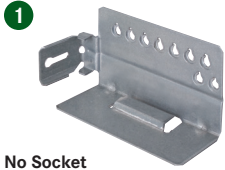

No Socket



With Socket

- 19mm rear mounting brackets
- Side-to-side adjustment $\pm 6\text{mm}$ ($1/4''$)
- Sockets attach to cabinet member with Euro screws

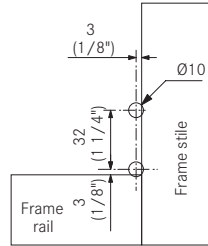

Description	Item No.	PU
1 V-notch, metal, no socket, left	02212-12	200
V-notch, metal, no socket, right	02213-12	200
2 V-notch, metal, with socket, left	02216-12	200
V-notch, metal, with socket, right	02217-12	200

Drilling Template



- Use to precisely bore holes in the drawer back
- Use with a standard $1/4''$ (6mm) drill bit and stop collar

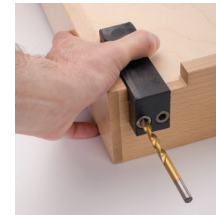

Left Side Drilling

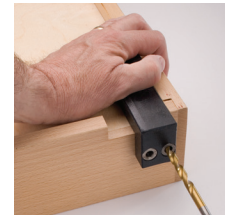

Right Side Drilling

Description	Item No.	PU
Elite Plus drilling template	02511-01	1

Screws

Euro Screw, Nickel-plated



Description	Item No.	PU
Euro Screw 11mm (7/16'') Pozi	499.360.61.1015	500
Euro Screw 13mm (1/2'') Pozi	499.360.61.3015	500

Wood Screw, Nickel-plated



Description	Item No.	PU
#6 x 5/8'' FHP, NI	81001-43	500
#6 x 3/4'' FHP, NI	81003-43	500

PU - Packaging unit



GRASS America Inc.
1202 NC Highway 66 South
Kernersville, NC 27284

Phone: 1-800-334-3512
Fax: 1-800-525-8406

Website: www.grassusa.com
E-mail: info@grassusa.com

GRASS Canada Inc.
10 Newgale Gate, Unit 7
Toronto, ON M1X 1C5

Phone: 1-800-461-4975
Fax: 1-416-335-5907

Internet: www.grasscanada.com
E-Mail: info@grasscanada.com



www.grassusa.com