



ZARGEN AND INTEGRA



G* GRASS®

ZARGEN & INTEGRA STEEL DRAWER SYSTEMS

Zargen and Integra steel drawer systems provide flexibility to please the most demanding design needs.







Zargen and Integra Drawer systems offer tried and tested technology.

Zargen – Maximum design versatility

From residential and office furniture to commercial and institutional settings, the versatile and reliable Zargen drawer system delivers superior performance. From cabinet members to full extension members to high sides to railing systems, the Zargen drawer system provides the flexibility to please the most demanding design needs for any application. Zargen offers endless possibilities for the well organized storage system. Made in the USA.

Integra – Tried and tested technology

The track-proven single-wall drawer system, Integra, offers cabinet makers a variety of design options for today's kitchens, baths, and case goods. A selection of standard drawers and deep drawers, pull-out shelves and inset drawers and custom sizable Pendaflex filing systems complete the Integra program. Excellent quality, flawless function, and clean lines create a superior drawer. For the customer, Integra offers maximum user benefits.

Two Minute Drawer

Zargen offers a drawer solution that saves time and money with its quick drawer box construction and simple installation. Zargen drawers can be assembled using the Grass Pro1 and the ZRam in less than 2 minutes. The Pro1 allows you to drill the front and back drawer panels and the ZRam presses the slides into place.

Zargen and Integra

Table of Content

	Description	Adjustment	Page
	Zargen Features and Benefits		6
	Zargen Technical Information		8
	Zargen 6436 <ul style="list-style-type: none"> • 213mm (8 3/8") Side Height • Integrated drawer slide and side 	<ul style="list-style-type: none"> • Height adjustment $\pm 2.0\text{mm}$ via cam • Side adjustment $\pm 1.5\text{mm}$ 	10
	Zargen 6236 <ul style="list-style-type: none"> • 149mm (5 7/8") Side Height • Integrated drawer slide and side 	<ul style="list-style-type: none"> • Height adjustment $\pm 2.0\text{mm}$ via cam • Side adjustment $\pm 1.5\text{mm}$ 	12
	Zargen 6136 <ul style="list-style-type: none"> • 117mm (4 5/8") Side Height • Integrated drawer slide and side 	<ul style="list-style-type: none"> • Height adjustment $\pm 2.0\text{mm}$ via cam • Side adjustment $\pm 1.5\text{mm}$ 	14
	Zargen 6036 <ul style="list-style-type: none"> • 85mm (3 3/8") Side Height • Integrated drawer slide and side 	<ul style="list-style-type: none"> • Height adjustment $\pm 2.0\text{mm}$ via cam • Side adjustment $\pm 1.5\text{mm}$ 	16
	Zargen 6026 <ul style="list-style-type: none"> • 85mm (3 3/8") Side Height • Integrated drawer slide and side 	<ul style="list-style-type: none"> • Height adjustment $\pm 2.0\text{mm}$ • Side adjustment $\pm 1.5\text{mm}$ 	18
	Zargen 6035 <ul style="list-style-type: none"> • 43mm (1 11/16") Side Height • Integrated drawer slide and side 	<ul style="list-style-type: none"> • Height adjustment $\pm 2.0\text{mm}$ via cam • Side adjustment $\pm 1.5\text{mm}$ 	20
	Zargen 6200 <ul style="list-style-type: none"> • Full Extension Slide Member • For use with all Zargen slides • Inserts easily between cabinet and drawer members 		22
	Zargen Soft-close <ul style="list-style-type: none"> • Liquid damper for improved performance 	<ul style="list-style-type: none"> • Height adjustment $\pm 2\text{mm}$ via elongated hole 	24
	Zargen 6100 <ul style="list-style-type: none"> • Railing System • For use with all Zargen slides • Allows end user to customize storage space 		26
	Pendaflex File Railing <ul style="list-style-type: none"> • Three file systems available • Easy installation 	<ul style="list-style-type: none"> • Accommodates letter and legal size folders 	27
	Machinery <ul style="list-style-type: none"> • Grass Pro 1 <ul style="list-style-type: none"> • Boring and insertion machine • Functional design • Easy maintenance • ZRam <ul style="list-style-type: none"> • For drawer assembly • Activated by air • For ZBox and Zargen assembly 		30
	Accessories		32

	Description	Adjustment	Page
	Integra Features and Benefits		36
	Integra Technical Information		38
	Integra 9313 <ul style="list-style-type: none"> • 149mm (5 7/8") Side Height • Integrated drawer slide and side 	<ul style="list-style-type: none"> • Height adjustment $\pm 2.0\text{mm}$ via cam • Side adjustment $\pm 2.0\text{mm}$ 	40
	Integra 9113 <ul style="list-style-type: none"> • 85mm (3 3/8") Side Height • Integrated drawer slide and side 	<ul style="list-style-type: none"> • Height adjustment $\pm 2.0\text{mm}$ via cam • Side adjustment $\pm 2.0\text{mm}$ 	42
	Integra Soft-close <ul style="list-style-type: none"> • Liquid damper for improved performance 	<ul style="list-style-type: none"> • Height adjustment $\pm 2\text{mm}$ via elongated hole 	44
	Roller Slide 1700/1702 <ul style="list-style-type: none"> • Single extension slide for Pull-out shelf • Bottom mount slide 		46
	Integra Interior Drawer		47
	Integra Rail 3500 <ul style="list-style-type: none"> • For Integra drawers with tall fronts • Gallery rail set 		48
	Integra 3595 Pendaflex File Railing <ul style="list-style-type: none"> • File Railing Set • Easy to construct 		49
	Integra Accessories		50

Features and Benefits

Zargen

Features



- Integrated drawer slide and drawer side
- White epoxy finish
- Load capacity 100 lb dynamic, 100 lb static
- Installation width 15.5mm (5/8")
- Made in the USA

Quick Assembly
with integrated front
fixing brackets

Built in drawer front bumpers
protect the drawer front during closing

Full extension capability
using Zargen 6200 system

Side adjustment
±1.5mm

Height adjustment
±2mm

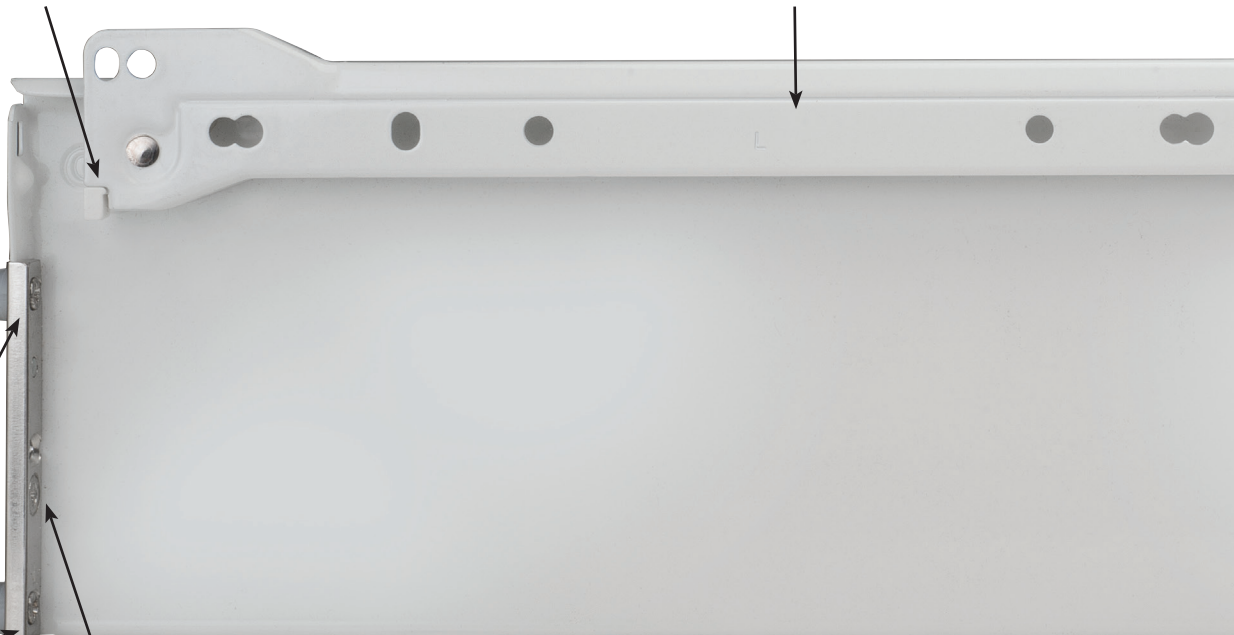

Versatile. Reliable. Proven.
Zargen delivers superior performance
with tried-and-tested technology.

Features

- Available in five drawer heights
 - 43mm (1 11/16")
 - 85mm (3 3/8")
 - 117mm (4 5/8")
 - 149mm (5 7/8")
 - 213mm (8 3/8")

Double stop

on drawer member locks the drawer safely in the open position

Parallel closing action

keeps the drawer front properly aligned

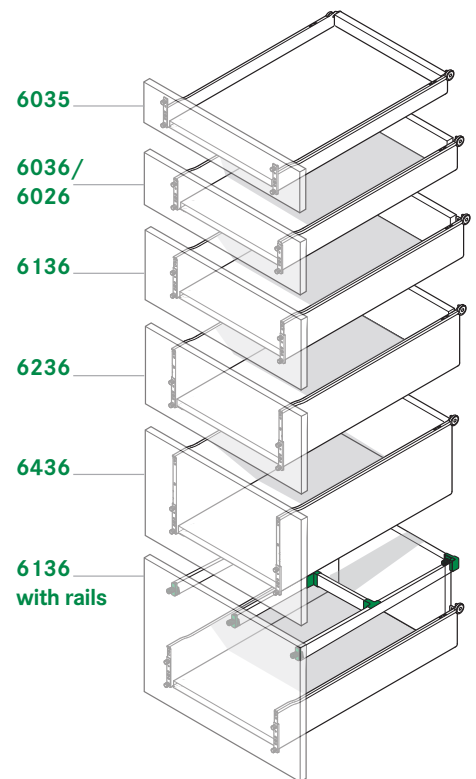

Technical Information

Zargen

Double Stop Rollers Built-in Stop

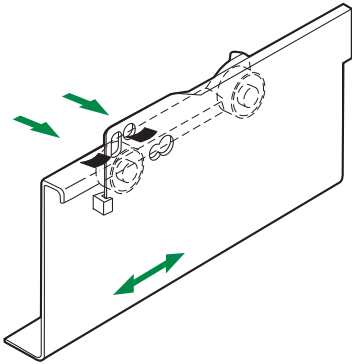

The double stop prevents the drawer from falling out while being extended. In addition, the drawer can be locked in the open position.

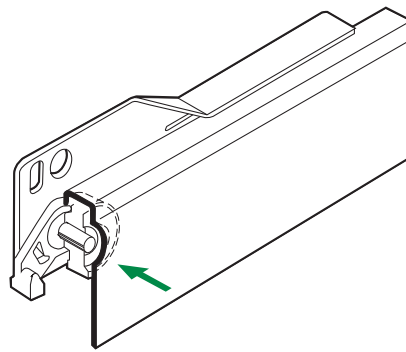

Special rollers provide lateral stability and a smooth glide. The rollers are tested for durability, and washers behind the rollers ensure stability.

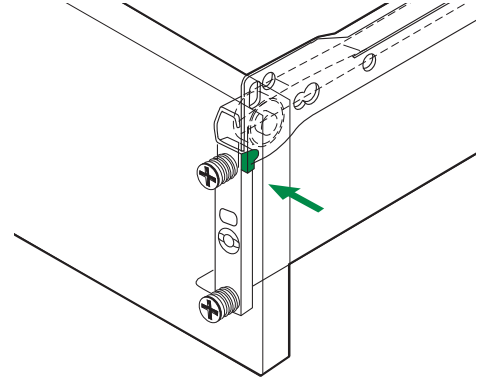

The integrated drawer stop protects the drawer front from impact during closing. Furthermore, it acts as a shock absorber and a self-alignment feature for the drawer fronts.

Closing

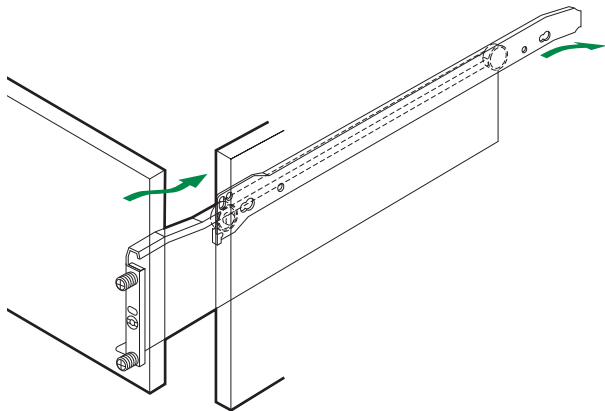

Self-Closing From a range of 60mm (2 3/8") out, the drawer closes quietly and smoothly. Drawers closed with force will not bounce back.

Minimum Reveal Minimum reveals are required between fronts due to the specifically formed closing action.

Parallel Closing The parallel closing action keeps the drawer front properly aligned with the cabinet front. Cabinet members feature elongated holes for height adjustment.

Adjustment Features 6036, 6035 Adjustment Features 6436, 6236, 6136

Height Adjustment:

Loosen screws 2 slightly. Adjust screw 1 (adjustment $\pm 2\text{mm}$). Tighten screws 2.

Side Adjustment:

Loosen screws 2 slightly. Adjust front to required position (adjustment range $\pm 1.5\text{mm}$). Tighten screws 2.

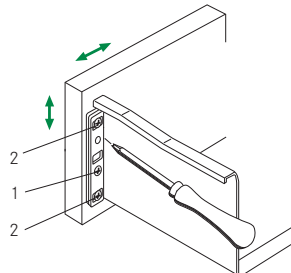

Height Adjustment:

Loosen screws 2 slightly. Adjust screw 1 (adjustment $\pm 2\text{mm}$). Tighten screws 2.

Side Adjustment:

Loosen screws 2 slightly. Adjust front to required position (adjustment range $\pm 1.5\text{mm}$). Tighten screws 2.

After adjusting front panel, mount fixing screw

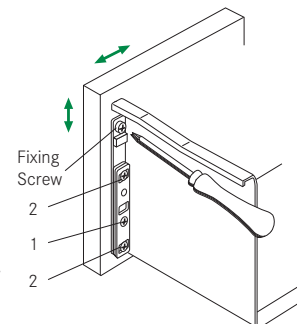

Weight Capacities per Pair of Slides

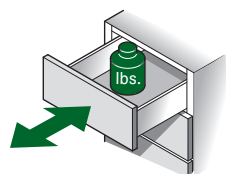

Zargen: 100 lb dynamic load rating; 100 lb static load rating

Zargen meets and exceeds the minimum requirements of ANSI/BHMA A156.9 standard, Grade 1

Cabinet Member **Installation**

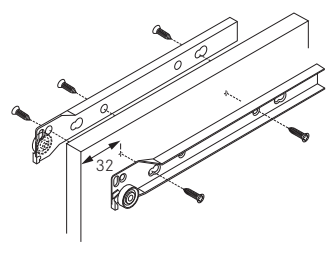
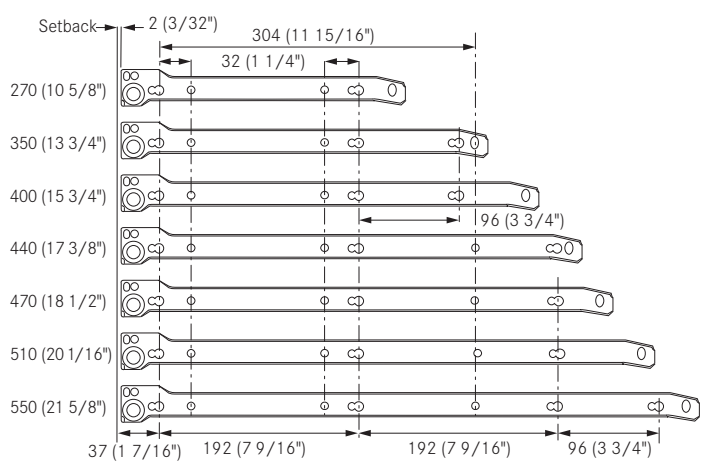

With Wood Screws
 (#6x5/8" Flat Head Phillips)
 the cabinet member is screwed directly on the end panel. To guarantee precise positioning, pre-center with a Grass pilot drill. For wood screws, use the front section of the double hole.

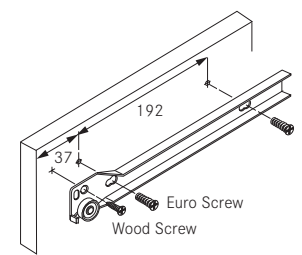

With Euro Screws (Flat Head Phillips)
 the cabinet member can be fastened into a pre-drilled 32mm hole system. See cabinet member drawing to the left for all fastening positions.

To simplify installation of the cabinet member, a unique double-hole pattern for 32mm and 37mm setback has been developed.

Captive Rollers **Full Extension Slide** **One Cabinet Member Slide System**

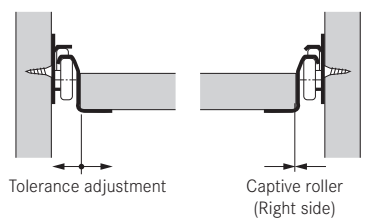

Manufacturing often is accompanied by tolerance problems. To avoid this situation, Grass slides are designed to eliminate side movement of the drawer. After installation, the right drawer member blends perfectly with the right cabinet member for guidance; the left side allows for cutting tolerance of the drawer and the cabinet components.

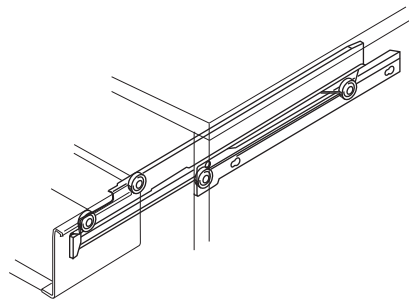

Using the 6200 member, the slide becomes fully extendible. An already existing drawer does not have to be altered. Only the cabinet member needs to be lowered 32mm.

Regular Extension

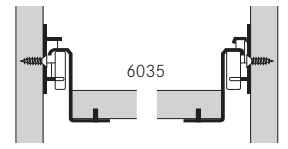

Full Extension

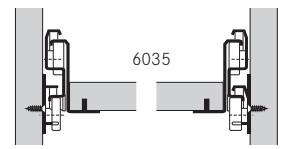

All slides of the Zargen system utilize the same cabinet member. The 6200 member can be inserted into the slides below when a full extension is needed. The example shown is 6035, see page 22 for more information.

System Organization

A unique feature of the Zargen System is its universal adaptability in cabinetry. The system offers function, drawer space utilization and economy. With regular drawers, inset pull-outs, divider railings and more the Zargen System provides a variety of organizational solutions.

Slide with railing (6036, 6100)

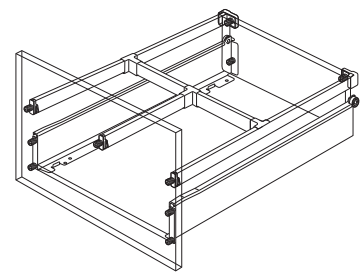

Zargen 6436

213mm (8 3/8") Side Height



- Integrated drawer slide and drawer side
- Self-closing feature with 60mm (2 3/8") closing range
- Built-in drawer front bumpers
- Quick assembly through dowelled and integrated front fixing brackets
- White epoxy finish
- Tolerance adjustment 2mm (3/32")
- Load capacity: 100 lb
- Adjustments: Cam height (± 2 mm), side (± 1.5 mm)
- Made in the USA

Zargen 6436 slide, 100 lb (45 kg)



Description	Slide Length	Item No.	PU
Zargen 6436/350	350 (13 3/4")	22910-03	5
Zargen 6436/400	400 (15 3/4")	22911-03	5
Zargen 6436/440	440 (17 3/8")	22708-03	5
Zargen 6436/470	470 (18 1/2")	22709-03	5
Zargen 6436/510	510 (20 1/16")	22710-03	5
Zargen 6436/550	550 (21 5/8")	22711-03	5
Zargen 6436/510	510 (20 1/16")	22710-12	200
Zargen 6436/550	550 (21 5/8")	22711-12	200

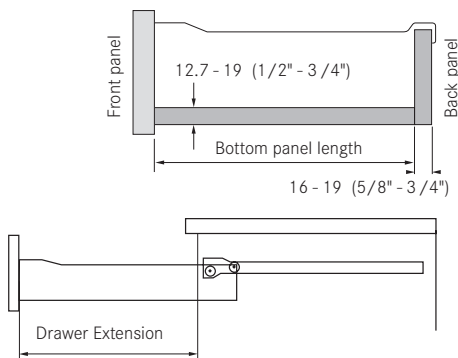

Slide Length	Bottom Panel Length		Extension	
	16mm (5/8") Back Panel	19mm (3/4") Back Panel	Single Stop	Double Stop
350 (13 3/4")	331 (13 1/16")	328 (12 15/16")	280 (11")	-
400 (15 3/4")	381 (15")	378 (14 7/8")	300 (11 13/16")	314 (12 3/8")
440 (17 3/8")	421 (16 9/16")	418 (16 7/16")	340 (13 3/8")	354 (13 15/16")
470 (18 1/2")	451 (17 3/4")	448 (17 5/8")	370 (14 9/16")	384 (15 1/8")
510 (20 1/16")	491 (19 5/16")	488 (19 3/16")	410 (16 1/8")	424 (16 11/16")
550 (21 5/8")	531 (20 7/8")	528 (20 13/16")	450 (17 11/16")	464 (18 1/4")

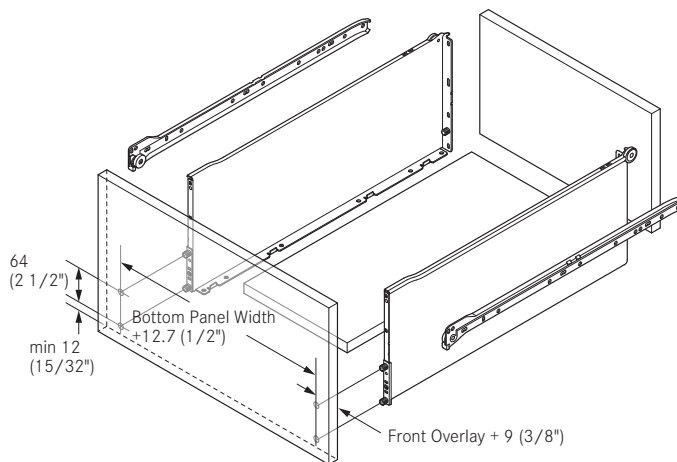

PU - Packaging unit

Drawer Back and Bottom Measurements

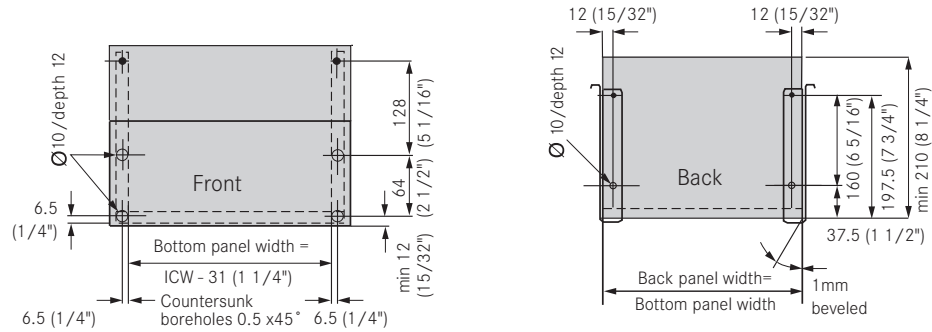

Drawer Installation Measurements

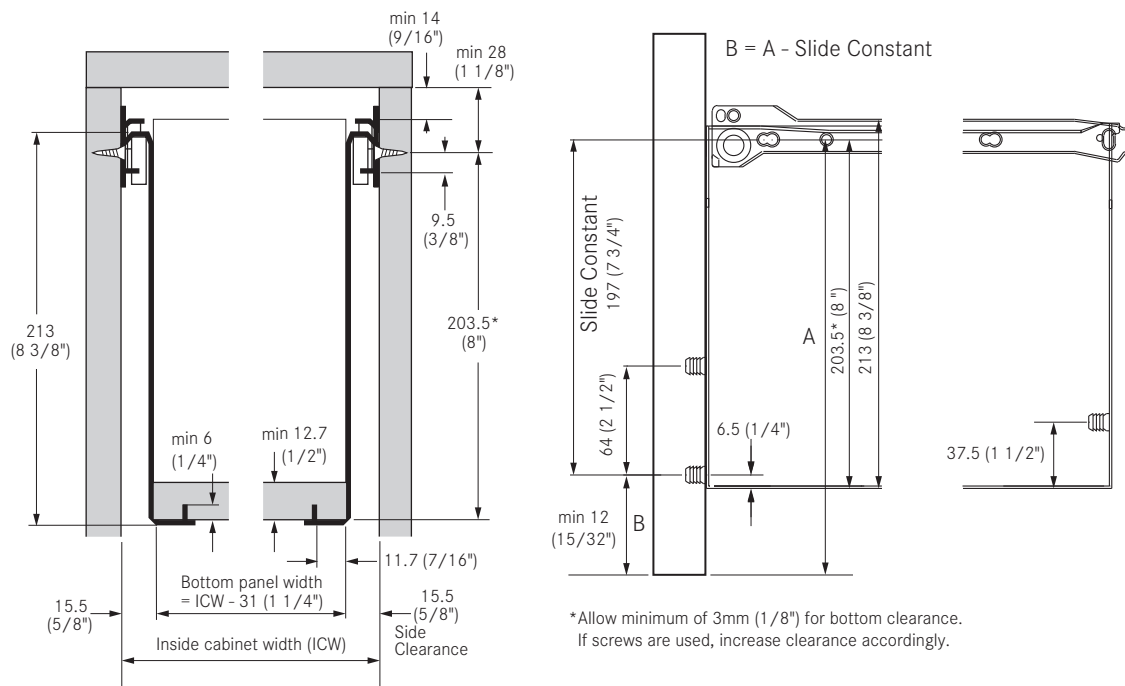

Drawer slide attachment:

Wood screws #6 x 5/8 FHP

Euro screw lengths 18mm, 13mm, 7.5mm

Bottom panel thickness: 12.7 - 19mm (1/2" - 3/4")

Back panel thickness: 16 - 19mm (5/8" - 3/4")

Back panel height: min 210mm (8 1/4")

All dimensions in millimeters.

Zargen 6236

149mm (5 7/8") Side Height



- Integrated drawer slide and drawer side
- Self-closing feature with 60mm (2 3/8") closing range
- Built-in drawer front bumpers
- Quick assembly through dowelled and integrated front fixing brackets
- White epoxy finish
- Tolerance adjustment 2mm (3/32")
- Load capacity: 100 lb
- Adjustments: Cam height (± 2 mm), side (± 1.5 mm)
- Made in the USA

Zargen 6236 slide, 100 lb (45 kg)



Description	Slide Length	Item No.	PU
Zargen 6236/350	350 (13 3/4")	22908-03	5
Zargen 6236/400	400 (15 3/4")	22909-03	5
Zargen 6236/440	440 (17 3/8")	22704-03	5
Zargen 6236/470	470 (18 1/2")	22705-03	5
Zargen 6236/510	510 (20 1/16")	22706-03	5
Zargen 6236/550	550 (21 5/8")	22707-03	5
Zargen 6236/350	350 (13 3/4")	22908-12	200
Zargen 6236/400	400 (15 3/4")	22909-12	200
Zargen 6236/440	440 (17 3/8")	22704-12	200
Zargen 6236/470	470 (18 1/2")	22705-12	200
Zargen 6236/510	510 (20 1/16")	22706-12	200
Zargen 6236/550	550 (21 5/8")	22707-12	200

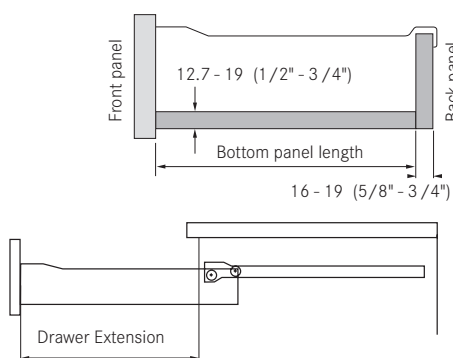

Slide Length	Bottom Panel Length		Extension	
	16mm (5/8") Back Panel	19mm (3/4") Back Panel	Single Stop	Double Stop
350 (13 3/4")	331 (13 1/16")	328 (12 15/16")	280 (11")	-
400 (15 3/4")	381 (15")	378 (14 7/8")	300 (11 13/16")	314 (12 3/8")
440 (17 3/8")	421 (16 9/16")	418 (16 7/16")	340 (13 3/8")	354 (13 15/16")
470 (18 1/2")	451 (17 3/4")	448 (17 5/8")	370 (14 9/16")	384 (15 1/8")
510 (20 1/16")	491 (19 5/16")	488 (19 3/16")	410 (16 1/8")	424 (16 11/16")
550 (21 5/8")	531 (20 7/8")	528 (20 13/16")	450 (17 11/16")	464 (18 1/4")

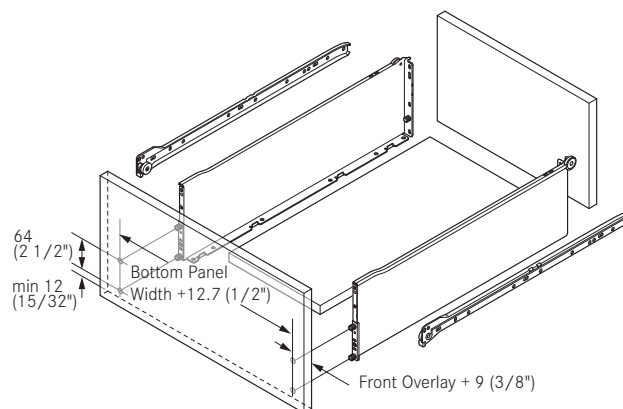

PU - Packaging unit

Drawer Back and Bottom Measurements

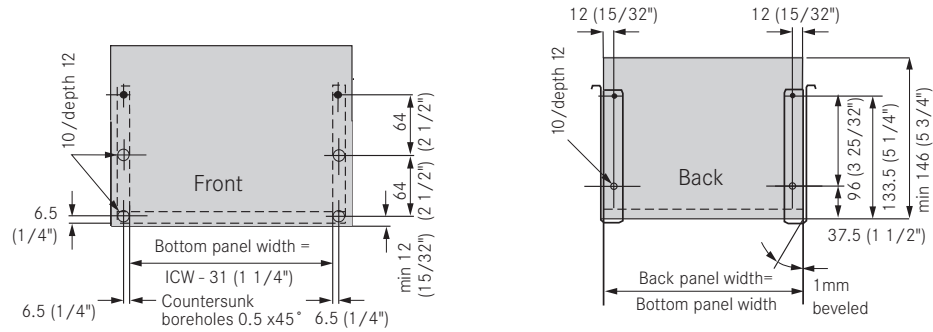

Drawer Installation Measurements

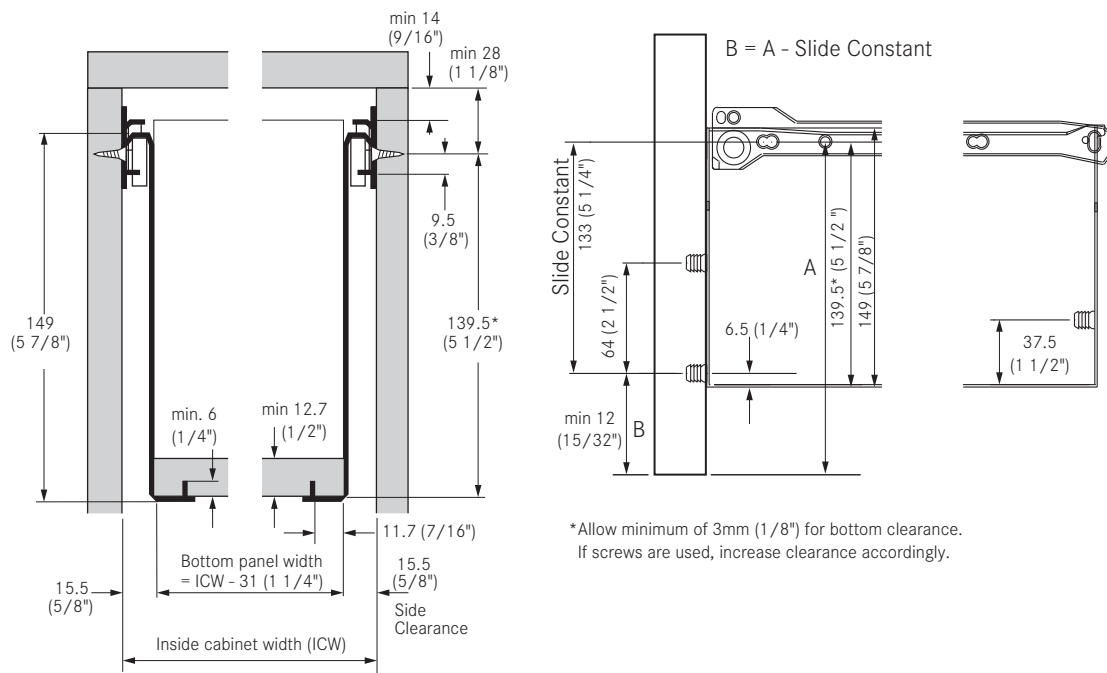

*Allow minimum of 3mm (1/8") for bottom clearance.
 If screws are used, increase clearance accordingly.

Drawer slide attachment:

Wood screws #6 x 5/8 FHP

Euro screw lengths 18mm, 13mm, 7.5mm

Bottom panel thickness: 12.7 - 19mm (1/2" - 3/4")

Back panel thickness: 16 - 19mm (5/8" - 3/4")

Back panel height: min 146mm (5 3/4")

All dimensions in millimeters.

Zargen 6136

117mm (4 5/8") Side Height



- Integrated drawer slide and drawer side
- Self-closing feature with 60mm (2 3/8") closing range
- Built-in drawer front bumpers
- Quick assembly through dowelled and integrated front fixing brackets
- White epoxy finish
- Tolerance adjustment 2mm (3/32")
- Load capacity: 100 lb
- Adjustments: Cam height (± 2 mm), side (± 1.5 mm)
- Made in the USA

Zargen 6136 slide, 100 lb (45 kg)



Description	Slide Length	Item No.	PU
Zargen 6136/350	350 (13 3/4")	22906-03	5
Zargen 6136/400	400 (15 3/4")	22907-03	5
Zargen 6136/440	440 (17 3/8")	22700-03	5
Zargen 6136/470	470 (18 1/2")	22701-03	5
Zargen 6136/510	510 (20 1/16")	22702-03	5
Zargen 6136/550	550 (21 5/8")	22703-03	5
Zargen 6136/400	400 (15 3/4")	22907-12	200
Zargen 6136/470	470 (18 1/2")	22701-12	200
Zargen 6136/510	510 (20 1/16")	22702-12	200
Zargen 6136/550	550 (21 5/8")	22703-12	200

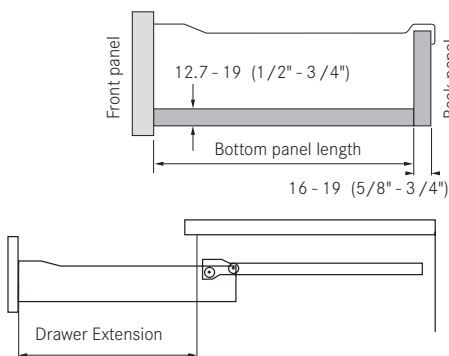

Slide Length	Bottom Panel Length		Extension	
	16mm (5/8") Back Panel	19mm (3/4") Back Panel	Single Stop	Double Stop
350 (13 3/4")	331 (13 1/16")	328 (12 15/16")	280 (11")	-
400 (15 3/4")	381 (15")	378 (14 7/8")	300 (11 13/16")	314 (12 3/8")
440 (17 3/8")	421 (16 9/16")	418 (16 7/16")	340 (13 3/8")	354 (13 15/16")
470 (18 1/2")	451 (17 3/4")	448 (17 5/8")	370 (14 9/16")	384 (15 1/8")
510 (20 1/16")	491 (19 5/16")	488 (19 3/16")	410 (16 1/8")	424 (16 11/16")
550 (21 5/8")	531 (20 7/8")	528 (20 13/16")	450 (17 11/16")	464 (18 1/4")

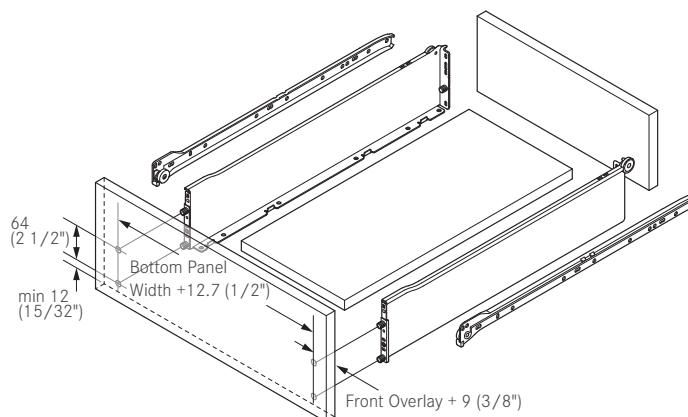

PU - Packaging unit

Drawer Back and Bottom Measurements

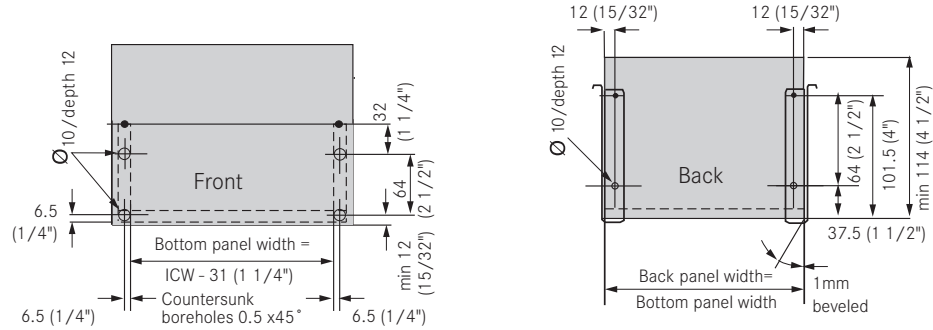

Drawer Installation Measurements

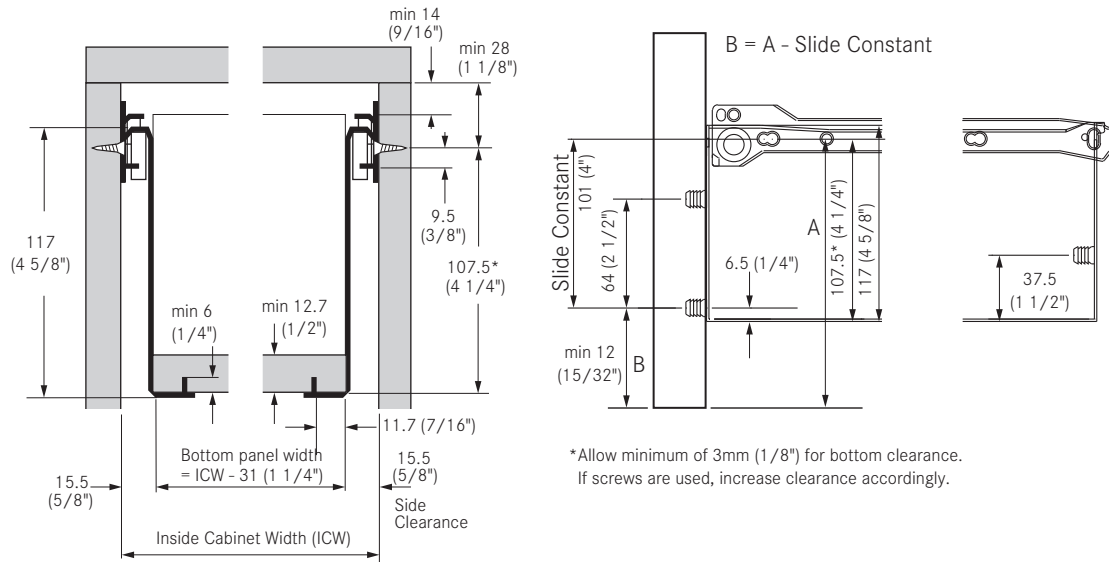

Drawer slide attachment:

Wood screws #6 x 5/8 FHP

Euro screw lengths 18mm, 13mm, 7.5mm

Bottom panel thickness: 12.7 - 19mm (1/2" - 3/4")

Back panel thickness: 16 - 19mm (5/8" - 3/4")

Back panel height: min 114mm (4 1/2")

All dimensions in millimeters.

Zargen 6036

85mm (3 3/8") Side Height

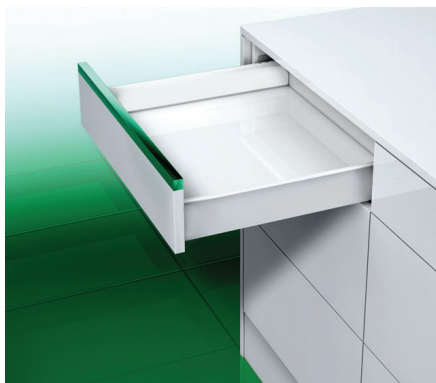

- Integrated drawer slide and drawer side
- Self-closing feature with 60mm (2 3/8") closing range
- Built-in drawer front bumpers
- Quick assembly through dowelled and integrated front fixing brackets
- White epoxy finish
- Tolerance adjustment 2mm (3/32")
- Load capacity: 100 lb
- Adjustments: Cam height (± 2 mm), side (± 1.5 mm)
- Made in the USA

Zargen 6036 slide, 100 lb (45 kg)



Description	Slide Length	Item No.	PU
Zargen 6036/270	270 (10 5/8")	11895-04	10
Zargen 6036/350	350 (13 3/4")	11896-04	10
Zargen 6036/400	400 (15 3/4")	12849-04	10
Zargen 6036/440	440 (17 3/8")	12850-04	10
Zargen 6036/470	470 (18 1/2")	12851-04	10
Zargen 6036/510	510 (20 1/16")	12852-04	10
Zargen 6036/550	550 (21 5/8")	11901-04	10
Zargen 6036/400	400 (15 3/4")	12849-16	400
Zargen 6036/440	440 (17 3/8")	12850-16	400
Zargen 6036/470	470 (18 1/2")	12851-16	400
Zargen 6036/510	510 (20 1/16")	12852-15	300
Zargen 6036/550	550 (21 5/8")	11901-15	300

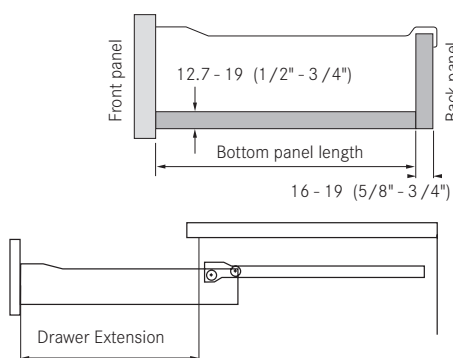

Slide Length	Bottom Panel Length		Extension	
	16mm (5/8") Back Panel	19mm (3/4") Back Panel	Single Stop	Double Stop
350 (13 3/4")	331 (13 1/16")	328 (12 15/16")	280 (11")	-
400 (15 3/4")	381 (15")	378 (14 7/8")	300 (11 13/16")	314 (12 3/8")
440 (17 3/8")	421 (16 9/16")	418 (16 7/16")	340 (13 3/8")	354 (13 15/16")
470 (18 1/2")	451 (17 3/4")	448 (17 5/8")	370 (14 9/16")	384 (15 1/8")
510 (20 1/16")	491 (19 5/16")	488 (19 3/16")	410 (16 1/8")	424 (16 11/16")
550 (21 5/8")	531 (20 7/8")	528 (20 13/16")	450 (17 11/16")	464 (18 1/4")

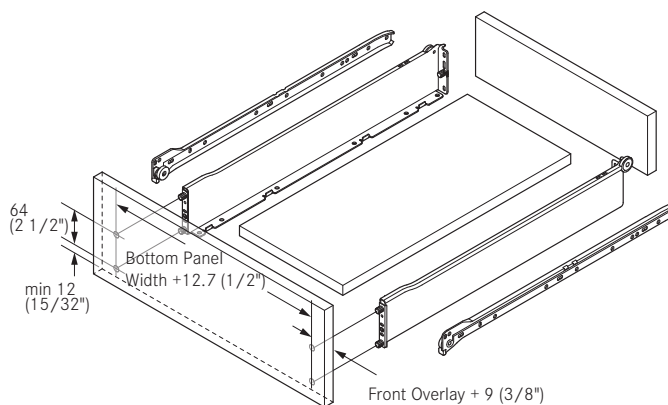

PU - Packaging unit

Drawer Back and Bottom Measurements

Drawer Back and Bottom Measurements with 6100 Railing Installation

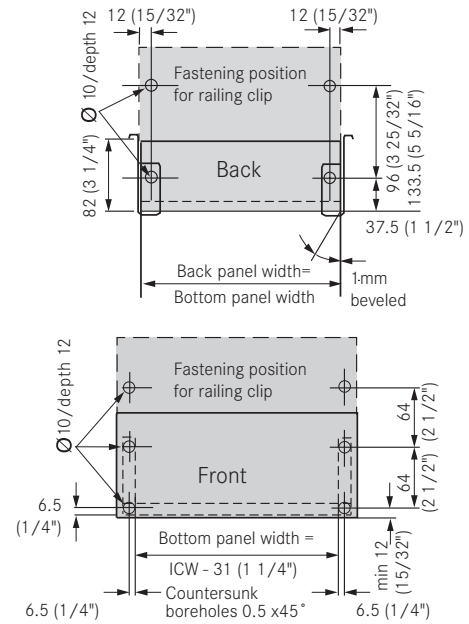
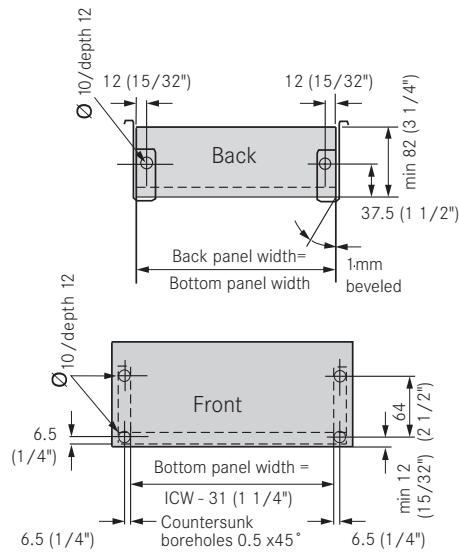

Drawer Installation Measurements

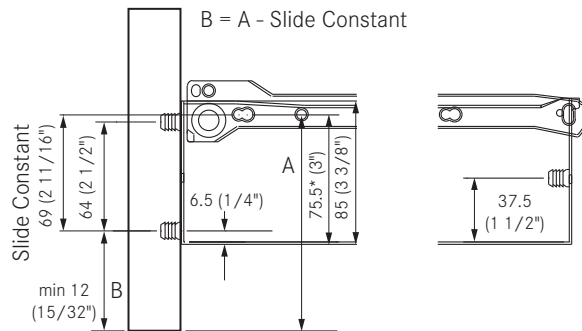
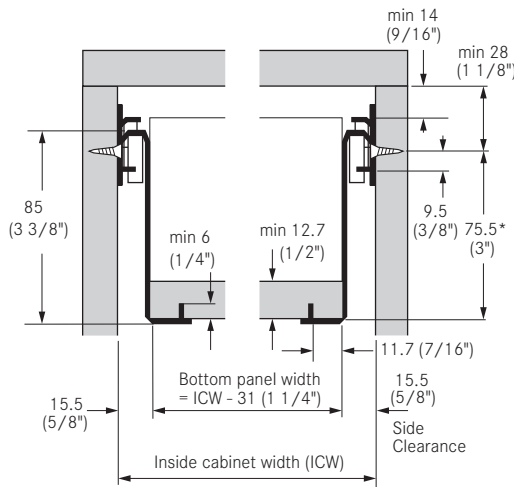

*Allow minimum of 3mm (1/8") for bottom clearance.
If screws are used, increase clearance accordingly.

Drawer slide attachment:

Wood screws #6 x 5/8 FHP

Euro screw lengths 18mm, 13mm, 7.5mm

Bottom panel thickness: 12.7 - 19mm (1/2" - 3/4")

Back panel thickness: 16 - 19mm (5/8" - 3/4")

Back panel height: min 82 (3 1/4")

All dimensions in millimeters.

Zargen 6026

85mm (3 3/8") Side Height



- Integrated drawer slide and drawer side
- Self-closing feature with 60mm (2 3/8") closing range
- Built-in drawer front bumpers
- Quick assembly through dowelled and integrated front fixing brackets
- White epoxy finish
- Tolerance adjustment 2mm (3/32")
- Load capacity: 100 lb
- Adjustments: height (± 2 mm), side (± 1.5 mm)
- Made in the USA

Zargen 6026 slide, 100 lb (45 kg)



Description	Slide Length	Item No.	PU
Zargen 6026/270	270 (10 5/8")	17766-04	10
Zargen 6026/350	350 (13 3/4")	17767-04	10
Zargen 6026/400	400 (15 3/4")	17768-04	10
Zargen 6026/440	440 (17 3/8")	11103-04	10
Zargen 6026/470	470 (18 1/2")	11128-04	10
Zargen 6026/510	510 (20 1/16")	17771-04	10
Zargen 6026/550	550 (21 5/8")	17772-04	10
Zargen 6026/400	400 (15 3/4")	17768-16	400
Zargen 6026/440	440 (17 3/8")	11103-16	400
Zargen 6026/470	470 (18 1/2")	11128-16	400
Zargen 6026/510	510 (20 1/16")	17771-16	400
Zargen 6026/550	550 (21 5/8")	17772-15	300

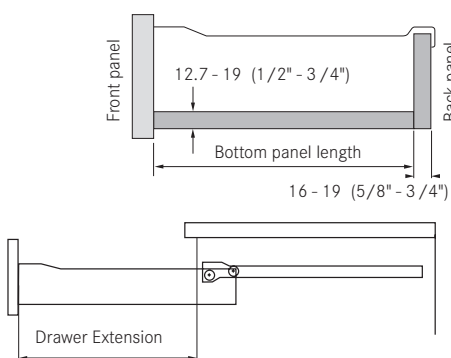

Slide Length	Bottom Panel Length		Extension	
	16mm (5/8") Back Panel	19mm (3/4") Back Panel	Single Stop	Double Stop
350 (13 3/4")	331 (13 1/16")	328 (12 15/16")	280 (11")	-
400 (15 3/4")	381 (15")	378 (14 7/8")	300 (11 13/16")	314 (12 3/8")
440 (17 3/8")	421 (16 9/16")	418 (16 7/16")	340 (13 3/8")	354 (13 15/16")
470 (18 1/2")	451 (17 3/4")	448 (17 5/8")	370 (14 9/16")	384 (15 1/8")
510 (20 1/16")	491 (19 5/16")	488 (19 3/16")	410 (16 1/8")	424 (16 11/16")
550 (21 5/8")	531 (20 7/8")	528 (20 13/16")	450 (17 11/16")	464 (18 1/4")

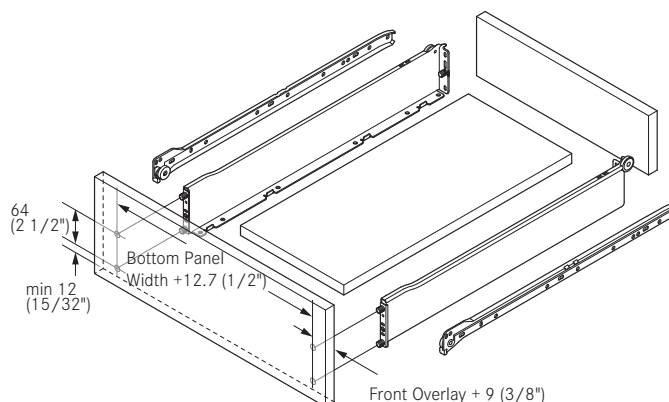

PU - Packaging unit

Drawer Back and Bottom Measurements

Drawer Back and Bottom Measurements with 6100 Railing Installation

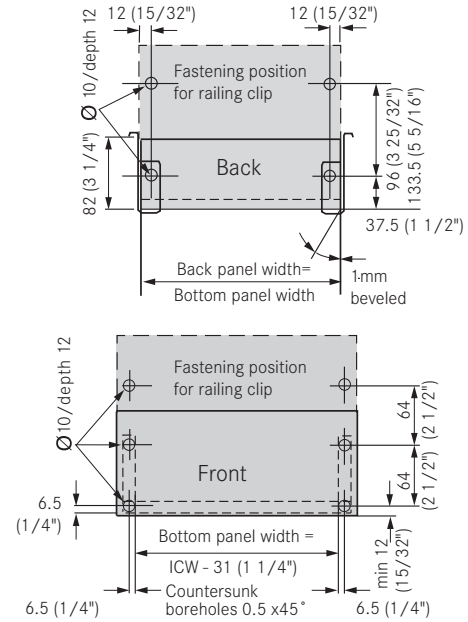
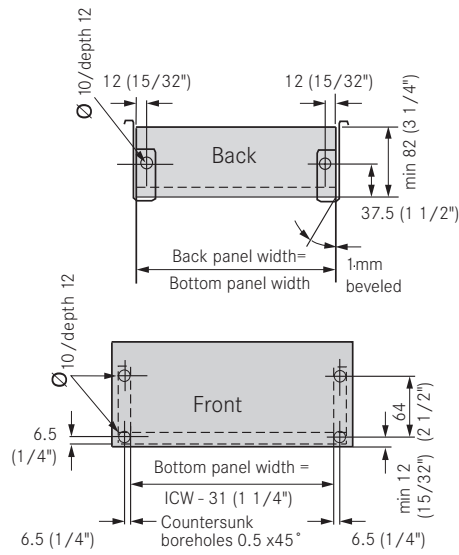

Drawer Installation Measurements

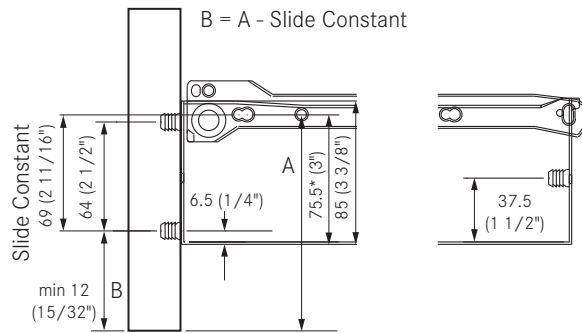
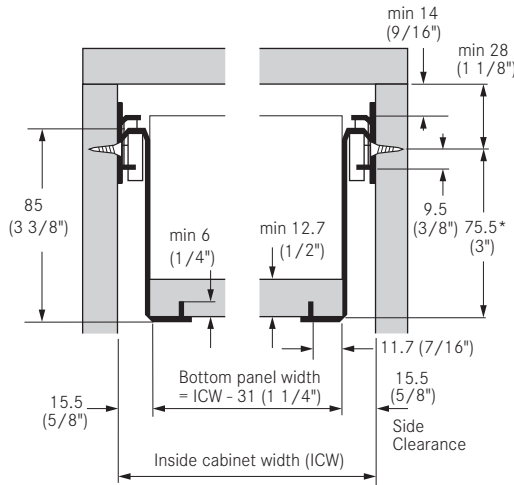

*Allow minimum of 3mm (1/8") for bottom clearance.
 If screws are used, increase clearance accordingly.

Drawer slide attachment:

Wood screws #6 x 5/8 FHP

Euro screw lengths 18mm, 13mm, 7.5mm

Bottom panel thickness: 12.7 - 19mm (1/2" - 3/4")

Back panel thickness: 16 - 19mm (5/8" - 3/4")

Back panel height: min 82 (3 1/4")

All dimensions in millimeters.

Zargen 6035

43mm (1 11/16") Side Height



- Integrated drawer slide and drawer side
- Self-closing feature with 60mm (2 3/8") closing range
- Built-in drawer front bumpers
- Quick assembly through dowelled and integrated front fixing brackets
- White epoxy finish
- Tolerance adjustment 2mm (3/32")
- Load capacity: 100 lb
- Adjustments: Cam height ($\pm 2\text{mm}$), side ($\pm 1.5\text{mm}$)
- Made in the USA

Zargen 6035 slide, 100 lb (45 kg)



Description	Slide Length	Item No.	PU
Zargen 6035/270	270 (10 5/8")	12119-04	10
Zargen 6035/350	350 (13 3/4")	12120-04	10
Zargen 6035/400	400 (15 3/4")	12121-04	10
Zargen 6035/440	440 (17 3/8")	12122-04	10
Zargen 6035/470	470 (18 1/2")	12123-04	10
Zargen 6035/510	510 (20 1/16")	12124-04	10
Zargen 6035/550	550 (21 5/8")	12125-04	10

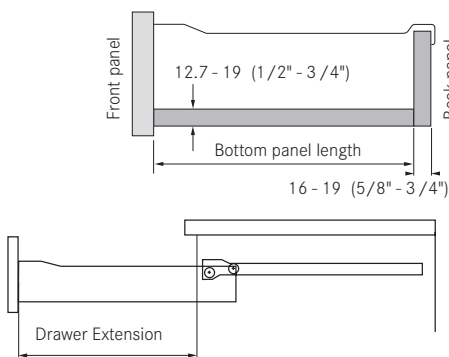

Slide Length	Bottom Panel Length		Extension	
	16mm (5/8") Back Panel	19mm (3/4") Back Panel	Single Stop	Double Stop
350 (13 3/4")	331 (13 1/16")	328 (12 15/16")	280 (11")	-
400 (15 3/4")	381 (15")	378 (14 7/8")	300 (11 13/16")	314 (12 3/8")
440 (17 3/8")	421 (16 9/16")	418 (16 7/16")	340 (13 3/8")	354 (13 15/16")
470 (18 1/2")	451 (17 3/4")	448 (17 5/8")	370 (14 9/16")	384 (15 1/8")
510 (20 1/16")	491 (19 5/16")	488 (19 3/16")	410 (16 1/8")	424 (16 11/16")
550 (21 5/8")	531 (20 7/8")	528 (20 13/16")	450 (17 11/16")	464 (18 1/4")

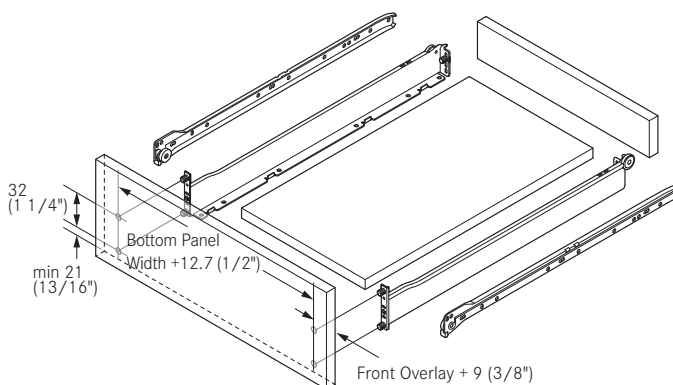

PU - Packaging unit

Drawer Back and Bottom Measurements

Drawer Back and Bottom Measurements with 6100 Railing Installation

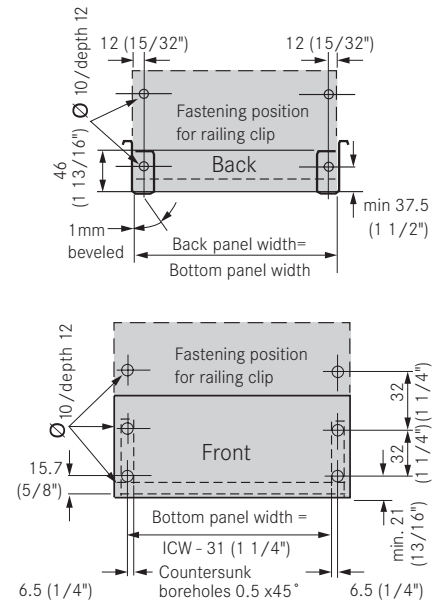
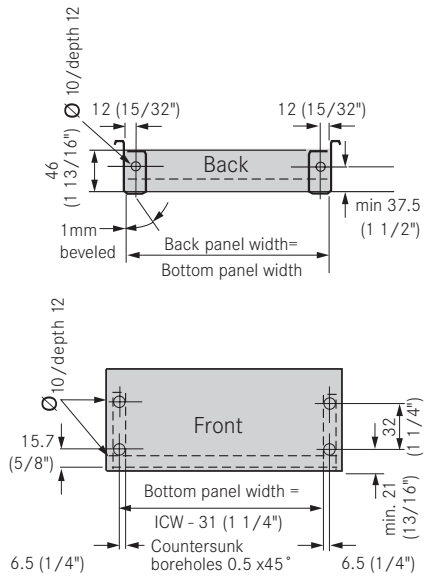

Drawer Installation Measurements

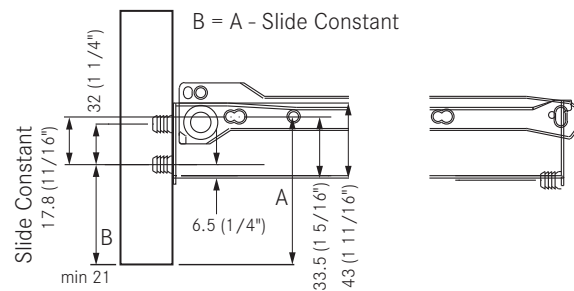
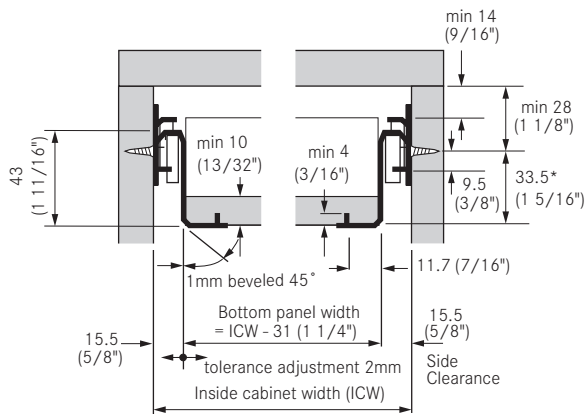

*Allow minimum of 3mm (1/8") for bottom clearance.
If Screws are used, increase clearance accordingly.

Drawer slide attachment:

Wood screws #6 x 5/8 FHP

Euro screw lengths 18mm, 13mm, 7.5mm

Bottom panel thickness: 12.7 - 19mm (1/2" - 3/4")

Back panel thickness: 16 - 19mm (5/8" - 3/4")

Back panel height: min 37.5mm (1 1/2")

All dimensions in millimeters.

Zargen 6200

Full Extension Slide Member

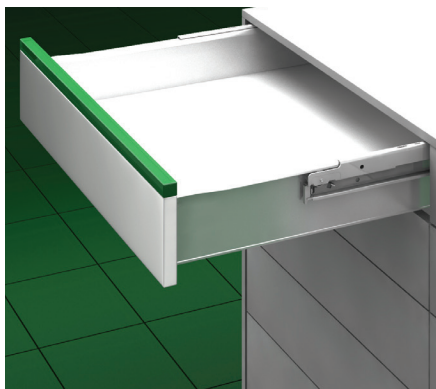

- Designed for use with Systems 6035, 6036, 6026, 6136, 6236, and 6436
- Provides full extension of drawers, pull-outs or shelves
- Inserts easily between the cabinet and drawer members
- Available in white epoxy finish
- Made in the USA

Zargen 6200 Full Extension Slide Member

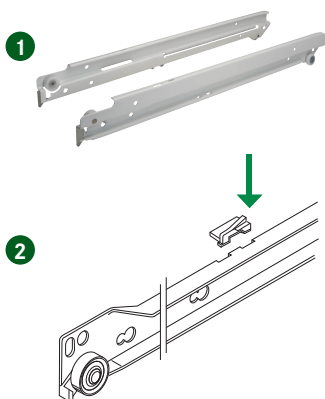

Note: product lead time approximately 4 weeks for order quantities of 400 or more.

Description	Slide Length	Item No.	PU
1 Zargen 6200/270	270 (10 5/8")	12754-04	10
Zargen 6200/350	350 (13 3/4")	12755-04	10
Zargen 6200/400	400 (15 3/4")	12756-04	10
Zargen 6200/440	440 (17 3/8")	12757-04	10
Zargen 6200/470	470 (18 1/2")	12758-04	10
Zargen 6200/510	510 (20 1/16")	12759-04	10
Zargen 6200/550	550 (21 5/8")	12760-04	10
2 Spare guide clip		61440-38	10

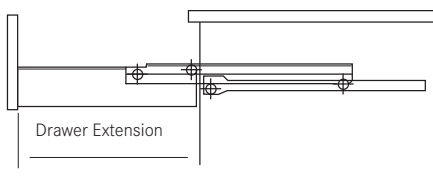

Slide Length	Extension	
	Single Stop	Double Stop
270 (10 5/8")	275 (10 13/16")	-
350 (13 3/4")	355 (14")	-
400 (15 3/4")	405 (15 15/16")	419 (16 3/8")
440 (17 3/8")	445 (17 1/2")	459 (18 1/16")
470 (18 1/2")	475 (18 11/16")	489 (19 1/4")
510 (20 1/16")	515 (20 1/4")	529 (20 13/16")
550 (21 5/8")	555 (21 7/8")	569 (22 3/8")

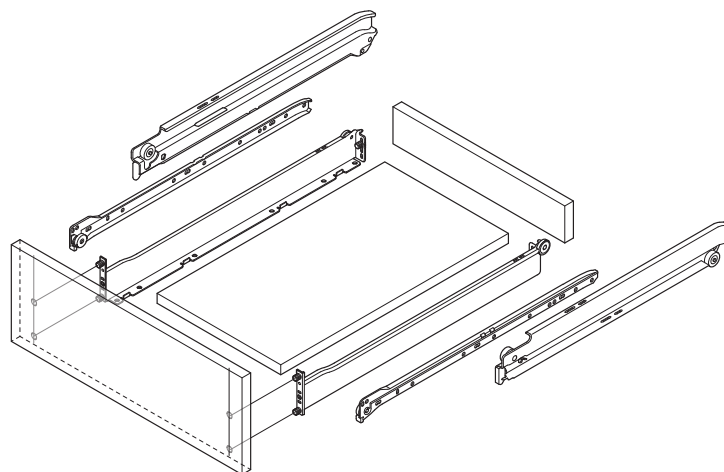

PU - Packaging unit

6200 Drawer Installation Measurements

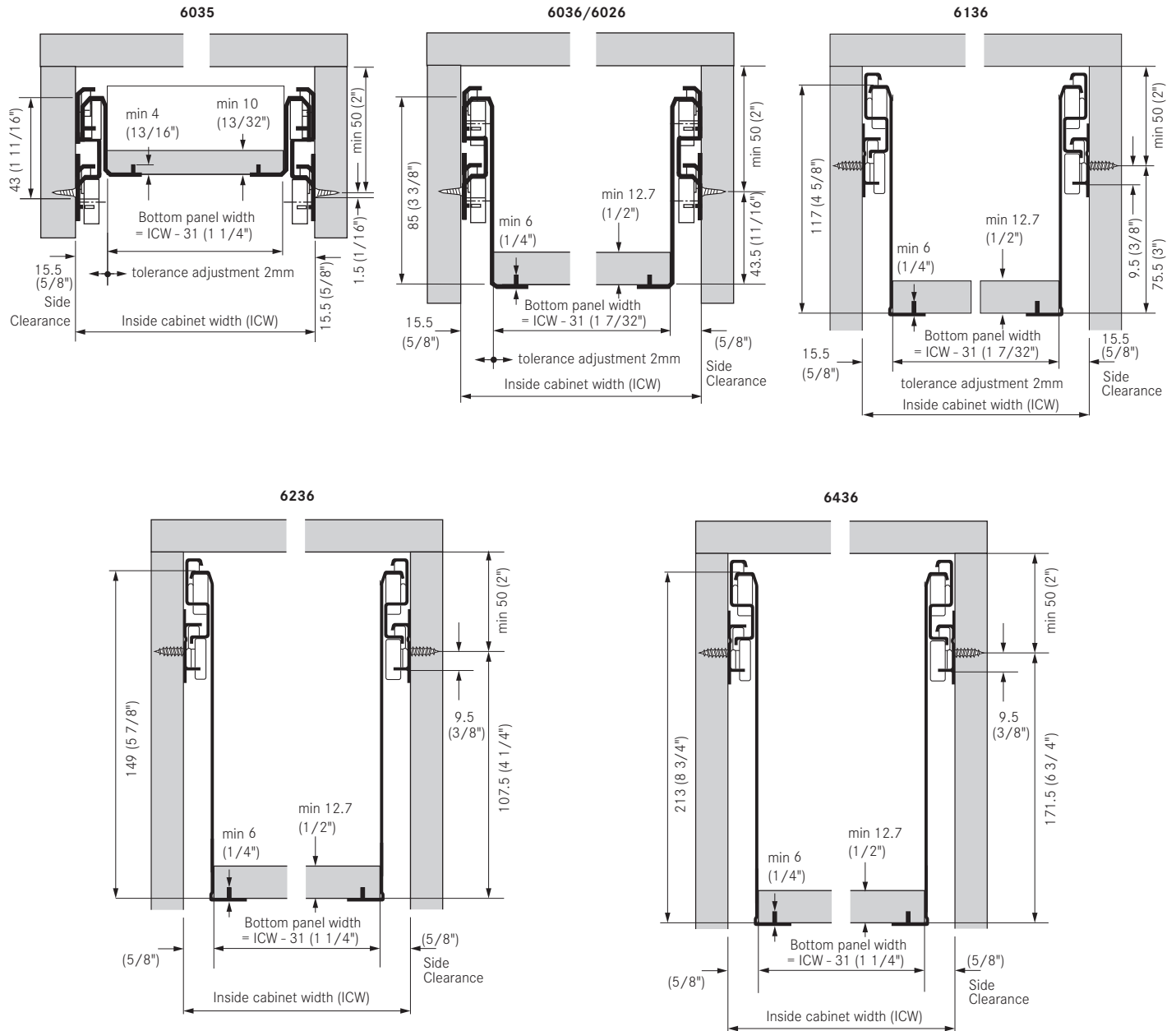

Drawer slide attachment:

Wood screws #6 x 5/8 FHP

Euro screw lengths 18mm, 13mm, 7.5mm

6200 Member Installation

1. Attach spare guide clip to left cabinet member to prevent full extension member from slipping.
2. Mount cabinet member of the drawer slide (System 6035, 6026, 6036, 6136, 6236 or 6436) according to installation measurements.
3. Install full extension slide member by simple insertion.
4. Insert drawer, pull-out or shelf.

All dimensions in millimeters.

Zargen Soft-close

Damper set

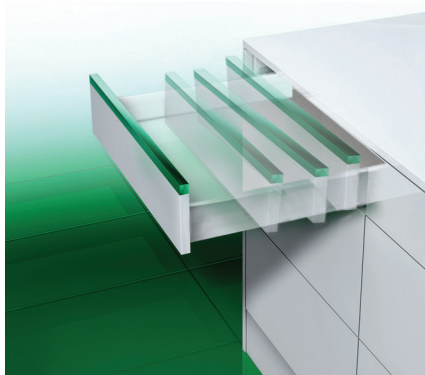

- Add-on damper creates a smooth soft-close action
- Liquid closing mechanism for improved performance
- Three options for various load capacities
- Height adjustment $\pm 2\text{mm}$ via elongated hole
- Secure striker plate engagement
- Actuator design allows for flush mounting
- Set includes: damper and actuator unit

Soft-close Damper



Description	Load Capacity	Item No.	PU
15 kg Damper set	33 lb	02564-11	140
30 kg Damper set	66 lb	02572-11	140
70 kg Damper set	154 lb	02565-11	140

Note: Damper sets do not include screws.

Soft-close Damper Placement

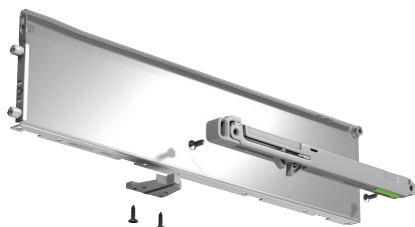

Dampers per drawer

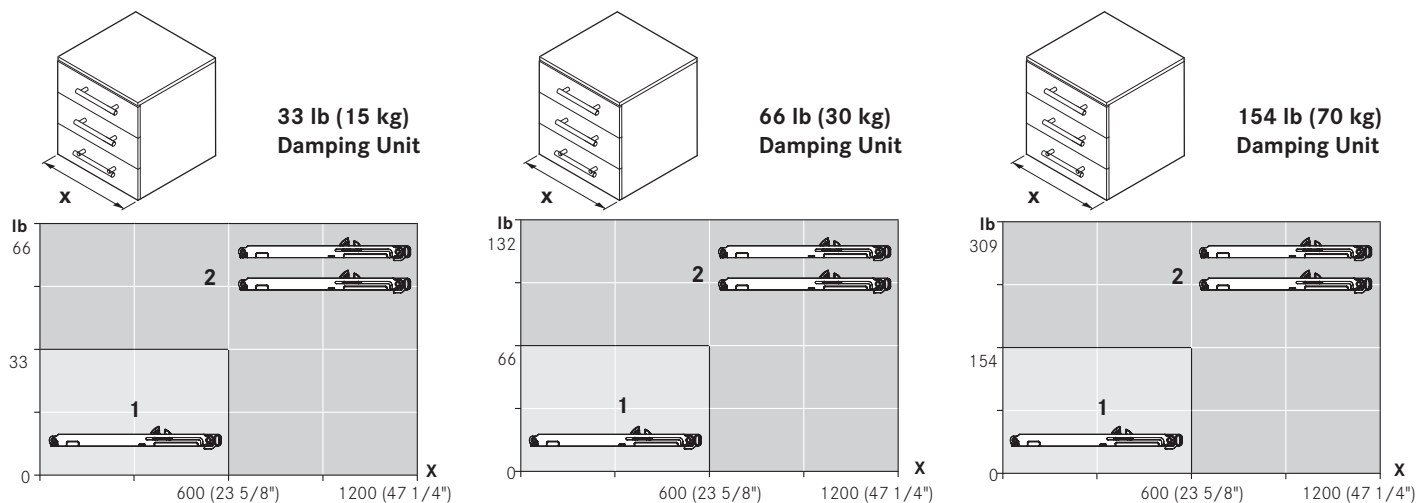

PU - Packaging unit

Product specifications

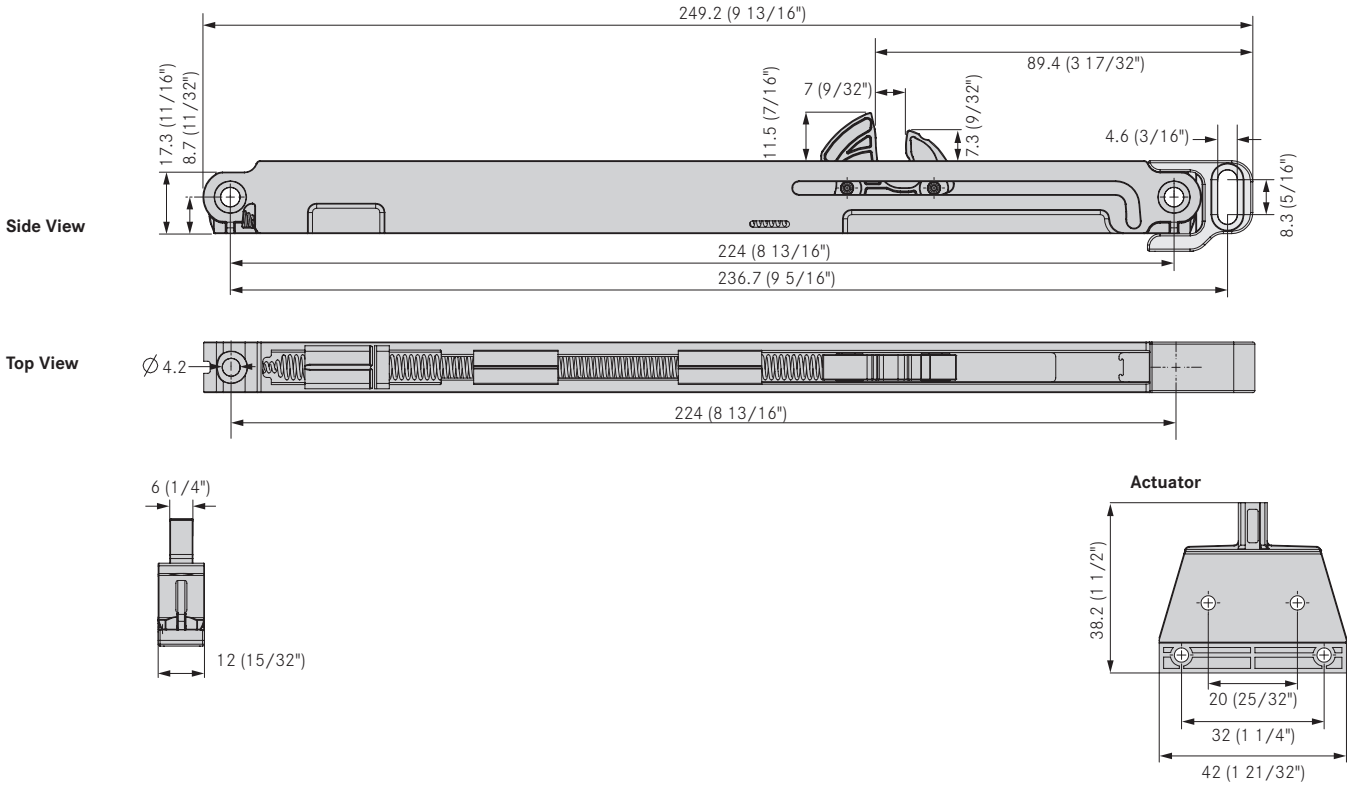

Mounting dimensions

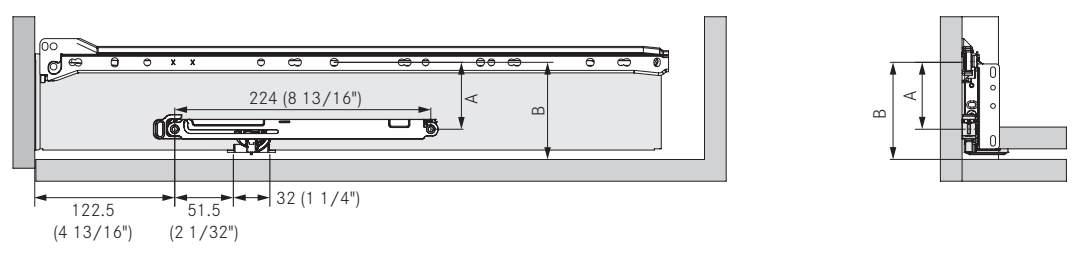

Recommended screws are:
 #4 x 1/2" Phillips flat head wood screws
 #4 x 3/4" Phillips pan head wood screws

Zargen	A	B
43	16.5	43
85	58.5	85
117	90.5	117
149	122.5	149
213	186.5	213

6100 Railing System

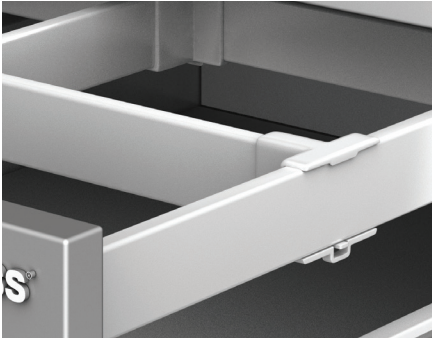

- Designed for use with Systems 6610, 6035, 6036, 6026, 6136, 6236, and 6436
- Easy to construct
- Allows end user to customize storage space
- Includes convenient rail dividers
- Available in white

6100 Railing System

Description	Slide Length	Item No.	PU
A 6100-02 Side Railing 345 (13 9/16")	350 (13 3/4")	F085098128211	20
6100-02 Side Railing 395 (15 9/16")	400 (15 3/4")	F085096773211	20
6100-02 Side Railing 435 (17 1/8")	440 (17 3/8")	F085096774211	20
6100-02 Side Railing 465 (18 5/16")	470 (18 1/2")	F085096775211	20
6100-02 Side Railing 505 (20")	510 (20 1/16")	F085096776211	20
6100-02 Side Railing 545 (21 3/8")	550 (21 5/8")	F085097210211	20
B 6100-02 Divider Railing - cut to size	Railing length 1000 (39 3/8")	F085096783211	20

Description	Item No.	PU
1 6150-01 Front railing clip, dowelled	F145096360111	20
2 6150-HF Front partition clip, 4.2mm screw-on	F145098829111	20
3 6150-02 Back railing clip, dowelled	F145096719123	100
4 6150-03 Back railing clip, 4.2mm screw-on	F145096769111	20
5 6150-20 Back partition clip, 4.2mm screw-on	F145097480111	20
6 6180-01 Divider railing clip	F145096770111	20
7a 6190-01 Corner bracket, LH	F145096771111	20
7b 6190-01 Corner bracket, RH	F145096772111	20

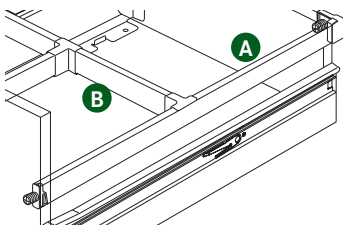

Front railing clip
Dowelled

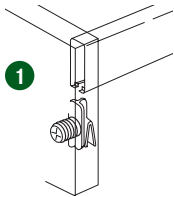

Front partition clip
Screw-on

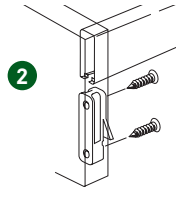

Back railing clip
Dowelled

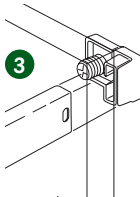

Back railing clip
Screw-on

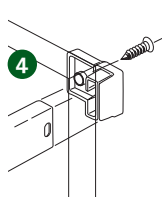

Back partition clip
Screw-on

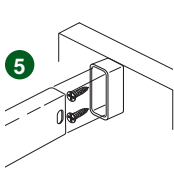

Divider railing clip

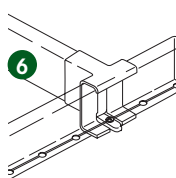

Corner Bracket

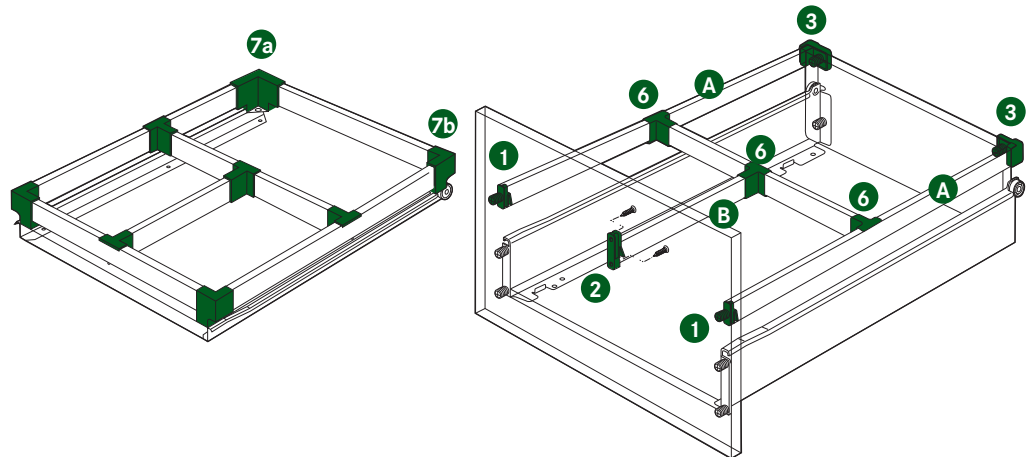
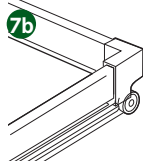
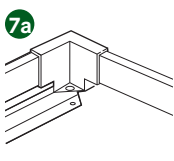

PU - Packaging unit

Pendaflex

6110 File Railing

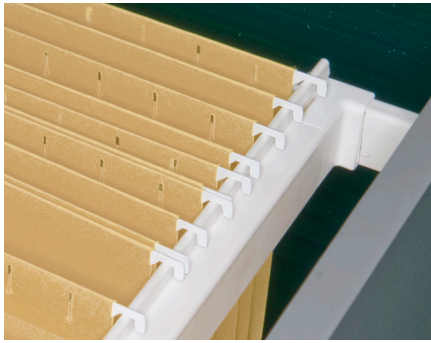

- The Pendaflex Rail 6110 provides a lip for drop in file folders. It is cut to a desired length and attached over the 6100 side railing.
- Use in conjunction with Zargen
- Easy to construct
- White plastic

File Rail 6110

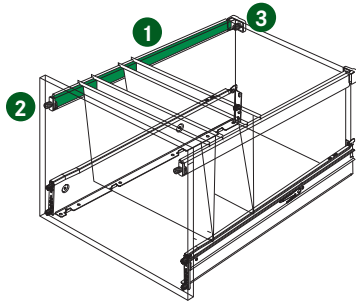

Description	Length	Item No.	PU
1 Pendaflex Rail 6110	1100 (43 5/16")	F145099062211	20
2 Front railing clip, doweled, white		F145096360111	100
3 Back railing clip, doweled, white		F145096719123	100

Drawer Measurements

Inside Cabinet Width

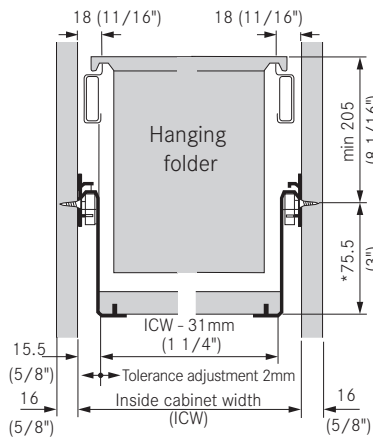

*6036 measurement used.
For other drawer heights, refer to the appropriate page.

ICW = Inside Cabinet Width
Legal Size paper:
ICW = 418mm (16 7/16")
Letter size Paper:
ICW = 342mm (13 7/16")

Drilling Patterns for Pendaflex File Drawers

Front panel
(manual and automatic assembly)

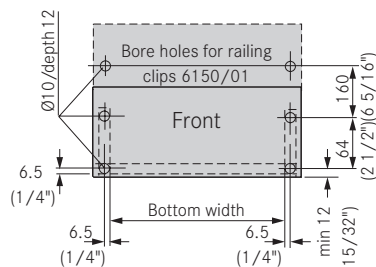

Back panel
(automatic assembly)

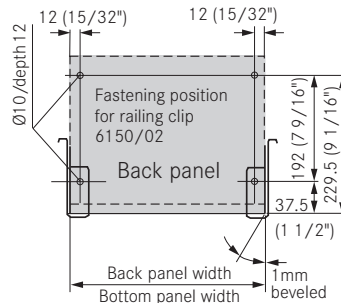

Back panel
(manual assembly)

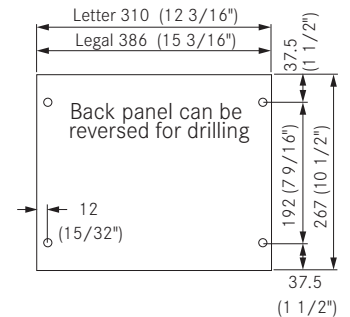

Pendaflex

File Railing



- Designed for use with metal drawer system or wood drawer application
- File bar accommodates lateral file application
- Easy to construct
- Available in white finish

US File Rail

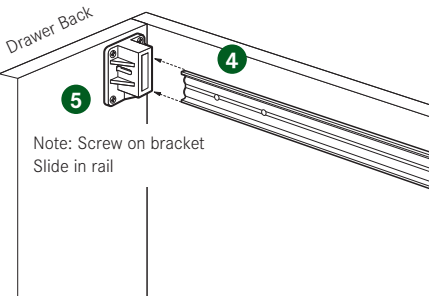
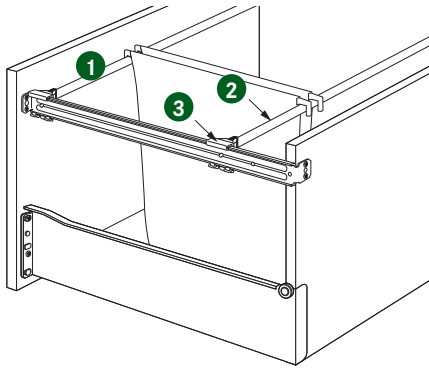

Description	Use With Slide Length	Item No.	PU
1 US/468.5 Side Rail	470 (18 1/2")	01692-05	20
US/508.5 Side Rail	510 (20 1/16")	01690-05	20
US/548.5 Side Rail	550 (21 5/8")	01686-05	20
2 711 (28") File Bar		30890-05	20
3 Lateral File Clip		30954-39	20
4 US/442.5 Partition Rail	470 (18 1/2")	01693-05	20
US/482.5 Partition Rail	510 (20 1/16")	01691-05	20
US/522.5 Partition Rail	550 (21 5/8")	01687-05	20
5 Partition Bracket		30956-39	20

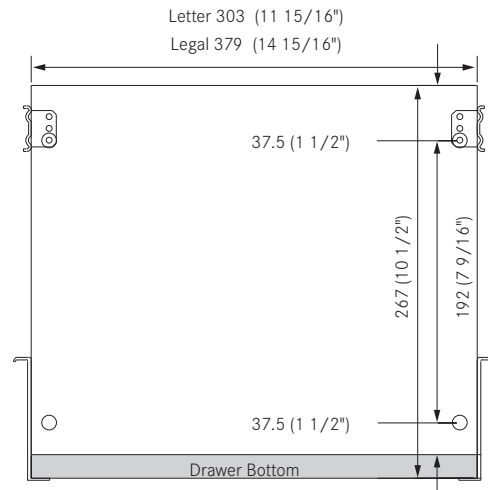

PU - Packaging unit

3595 Pendaflex Aluminum File Railing

For Zargen

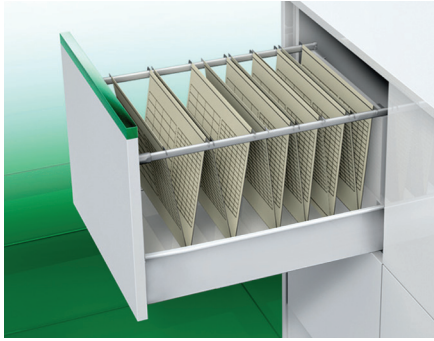

- For Zargen and Integra drawer systems
- Install file railing system independent from drawer system
- Front tilt adjustment
- Oval aluminum anodized

3595 File Rail

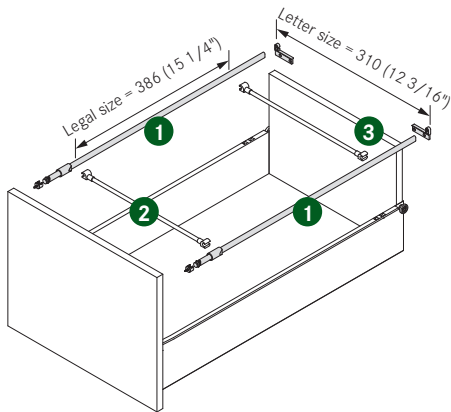

Description	Length	Item No.	PU
1 File Railing Set	500 (20")	F084074850511	20
File Railing Set	550 (22")	F084074851511	20
2 Divider Rail - cut to size	1200 (47 1/4")	F084074854223	20
3 Divider Clips		F084074857133	20

File Railing set consists of:

- 2 Side gallery rails
- 2 Front fixing parts
- 2 Back fixing parts
- 2 Cover caps

Front Tilt Adjustment

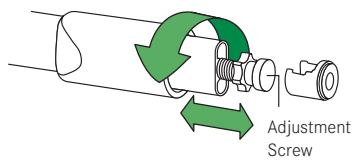

Installation Instructions

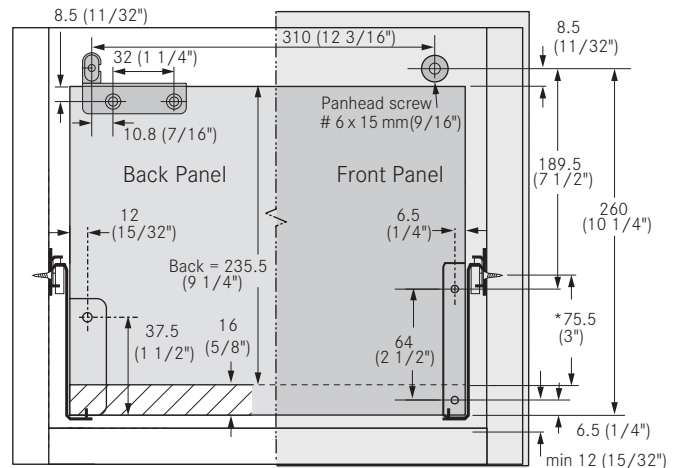

* 6036 measurement used. For other drawer heights, refer to the appropriate page.

Machinery

Grass PRO1 and ZRam for Zargen and ZBox Assembly

Grass PRO1 for Zargen and ZBox



- Depth stop can be adjusted to material thickness
- Functional design
- Easy, fast and efficient operation
- Easy maintenance
- 3 spindle gear box

Description	Item No.	PU
220v single phase pneumatic	80131	1
220v three phase pneumatic	80132	1
110v single phase pneumatic	80068	1



Description	Item No.	PU
Extension fence 300mm to 1250mm	88612-01	1

Zargen and ZBox Conversion Kit

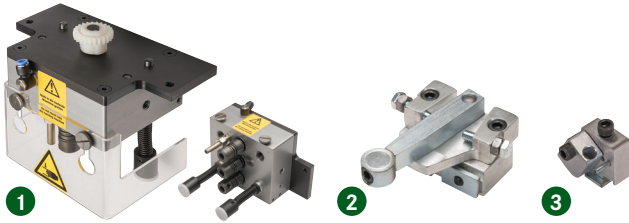

Description	Item No.	PU
1 PRO1 Gear box	80151	1
2 PRO1 Side-to-side Stop	80153	1
3 PRO1 13mm Fence Stop	80152	1
4 PRO1 Kit (gear box, fence and side stops)	80154	1

Bits

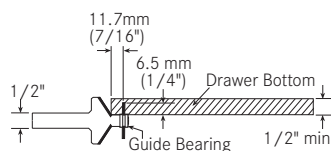
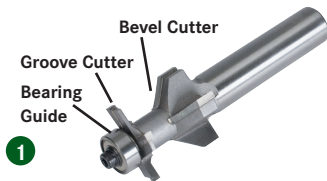

This bit is designed for grooving and beveling the drawer bottoms for the lipped version of the ZBox and Zargen drawer slide. The bit comes only with a 1/2" shank.



Two 00222-01 bits are needed for the Zargen and ZBox Grass PRO1 setup.

Description	Item No.	PU
1 Router bit	00197-01	1
2 10mm Carbide counter sink drill bit, LH	00222-01	1

ZRam



- Designed for semi-automated assembly of ZBox and Zargen slides
- Operated by a foot pedal – air required
- No adjustment required when using various heights or when switching slide types
- Economical solution for drawer assembly

Description	Item No.	PU
ZRam	93250-01	1
ZRam Retrofit Kit	69401	1

PU - Packaging unit

Assembly of Zargen

Grass PRO 1

To assemble, drill drawer back dowel holes for each side by positioning back against the side-to-side stop.

To ensure correct positioning of the drawer front dowel holes, place drilled drawer back against right side of 13mm stop. Set floating side stop at opposite end of panel. Drill bits are countersunk to allow for easy installation of dowels.

To drill right side of drawer front, place front against the 13mm stop. To drill left side, place front against floating side stop.

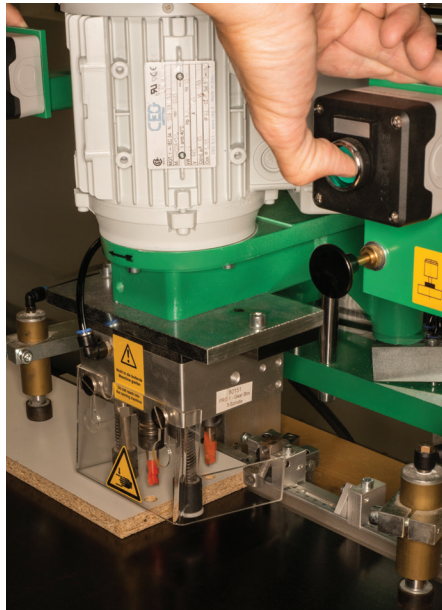

ZRam

To insert the slide, position the slide against the ZRam arm and place drawer back over the dowel. Repeat for other side.

Place drawer front face down on ZRam. Position slide over dowel holes and depress foot pedal. Repeat for other side.

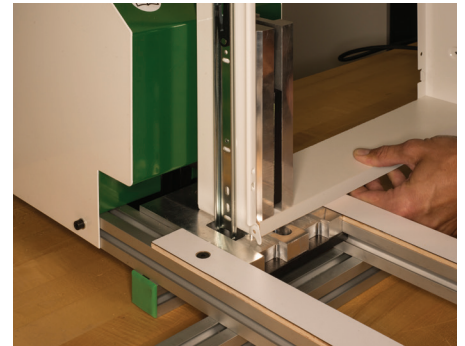
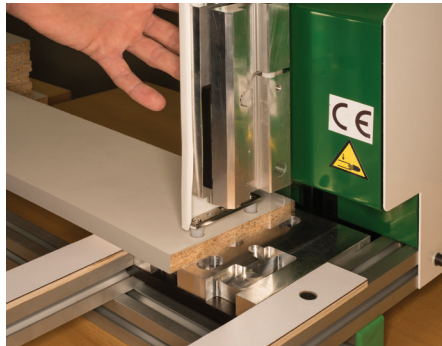

After assembly is complete, place Zargen drawer box on a stable surface and press bottom firmly over tabs.



Note: The assembly of the ZBox drawer system is the same process as the Zargen system.

Accessories

Zargen

6196 Bracket



- Attaches cabinet member of drawer slide if no side panel is available
- Bracket can be used for right or left
- Polybag includes 4 brackets with screws

Description	Item No.	PU
6196 Bracket	00432-08	50

Polybag set consists of:

- 4 - Brackets
- 8 - Screws #10 x 5/8" PHP Screws

6035

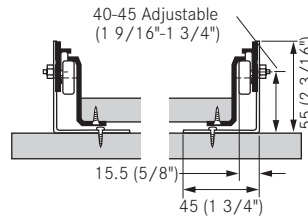

6036

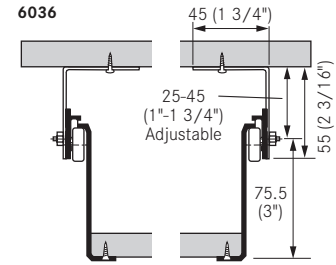

Rear Mounting Socket



- Drawer slide can slide in or out to achieve different cabinet depth
- Extra long length
- Socket can be stapled or screwed

Description	Item No.	PU
Rear mounting socket, left	13946-09	100
Rear mounting socket, right	13947-09	100
Rear mounting socket, left	13946-17	500
Rear mounting socket, right	13947-17	500

6195 Spacers for Cabinet Members



Designed for doors protruding into the cabinet and for inset drawers.

Description	Item No.	PU
1 6195 Spacer, 25mm	F145086478111	20
2 6195 Spacer, 11mm	89104-39	20
3 6195 Spacer/pin, 25mm	13097-39	20

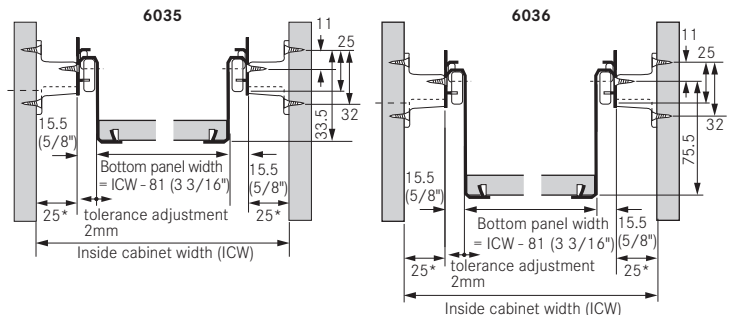

PU - Packaging unit

Accessories

Zargen

Pilaster Mounting Bracket

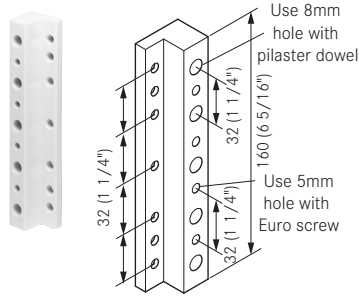

- Fits over 32mm line boring patterns
- Attaches to cabinet with Euro or wood screws
- Allows use of pilaster dowel on cabinet member for an adjustable roll out shelf.
- Allows roll out shelves to be adjustable in 32mm increments

Description	Item No.	PU
Pilaster Mounting Bracket	30912-12	200

Pilaster Dowels



- Allows for construction of adjustable pull-outs with any Zargen
- Drawer Slide System when attached to cabinet member
- Dowel requires an 8mm x 5/8" deep hole
- Attaches with a #6 x 5/8" or #6 x 1/2" FHP screw

Description	Item No.	PU
Pilaster Dowel, black	00395-43	500

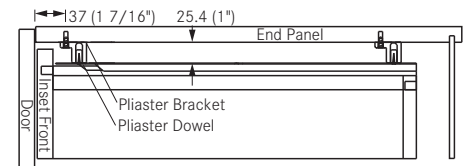

Example shown using 6036 slide with 19mm (3/4") front material

Door Protectors for Pull-outs



Protects door when insets are pulled out. Attached to the bottom of the pull-out.



Description	Item No.	PU
6197 Protector, left	F145088094 223	100
6197 Protector, right	F145088095 223	100

Door/Drawer Protector

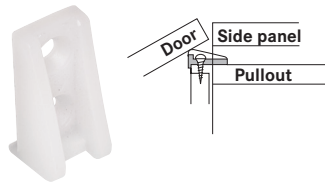

Attaches to side of wooden pull-out. Designed for inset pull-out trays for frame or frameless cabinetry.

Description	Item No.	PU
Door/drawer protector	13096-43	500

Roll-out Tray Bracket

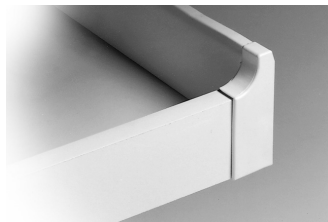

- Allows 6036/6026 slide to be used as roll out tray
- Tray front is 59mm (2 5/16")
- Bracket mounts to front of slide
- Color: white

Description	Item No.	PU
6036/6026 Roll out tray bracket - Polybag	30570-05	20
6036/6026 Roll out tray bracket set	30561-15	300
#4 X 3/8", NI screws	00073-43	500

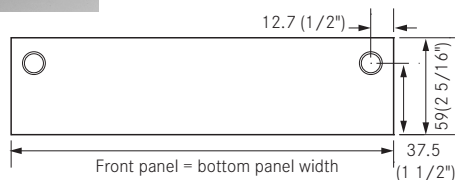

Polybag consists of:
 2 - Brackets, LH and RH
 2 - Clamps
 4 - #4 X 3/8", NI screws

Set consists of:
 2 - Brackets, LH and RH
 2 - Clamps

Accessories

Zargen

Zargen Front Bracket



- Position bracket on the inside edge of the face frame with the tab resting on the cross rail.
- Brackets can be stapled or screwed.

Description	Item No.	PU
Zargen front bracket	00228-09	100

Central Locking Device



- Use with most commercial gang lock system.
- Provides necessary match for gang lock pins to engage.

Description	Item No.	PU
Central locking device	F145088123238	300

6036 Support Bracket



- Attaches to the center of wide drawers for support.
- Elongated holes for drawer front adjustments.

Description	Item No.	PU
6036 Support bracket, nickel	22226-42	100

6036 Spacer for Inset Drawers

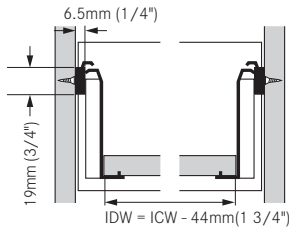

Description	Item No.	PU
6036 Spacer	00035-42	100

Screws

Euro Screw, Nickel-plated



Description	Item No.	PU
Euro Screw 11mm (7/16") Pozi	499.360.61.1015	500
Euro Screw 13mm (1/2") Pozi	499.360.61.3015	500

Wood Screw, Nickel-plated



Description	Item No.	PU
#6 x 5/8" FHP, NI	81001-43	500
#6 x 3/4" FHP, NI	81003-43	500

PU - Packaging unit



INTEGRA DRAWER SYSTEM

The single-wall steel drawer system that offers a range of design options.

Integra offers solutions for flexible production and provides a track proven record of quality in a variety of applications. The features for Integra include a dynamic load capacity of 100 lb, a parallel self-closing feature, and quick bottom mounting. A selection of standard drawers and deep drawers, pull-out shelves and soft-close drawers, and custom sizable Pendaflex filing systems complete the Integra program. Top quality and maximum functionality create a perfect drawer.



Features and Benefits

Integra

Features



- 2-Dimensional front adjustment
- Snap on bottom mounting
- Parallel self-closing feature
- Double stop
- Installation width 15.5mm (5/8")
- Load capacity: 100 lb dynamic, 125 lb static

Two front fixing bracket choices.

Both provide simple adjustments of drawer front gap

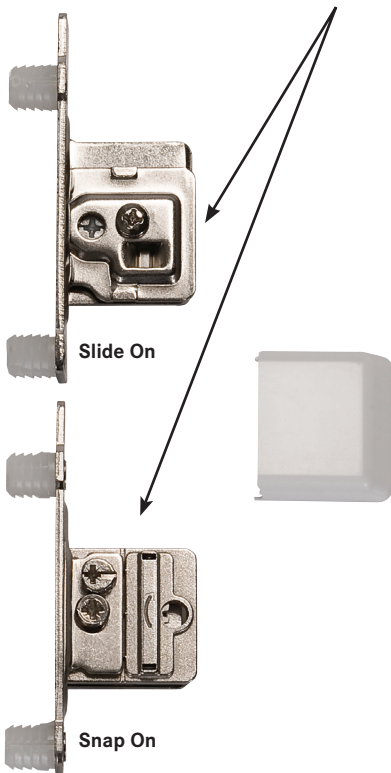

Smooth running

properties and self closing action provides optimum durability

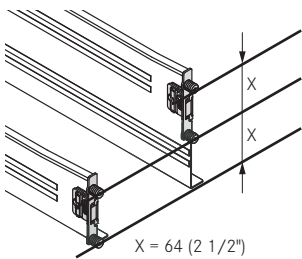
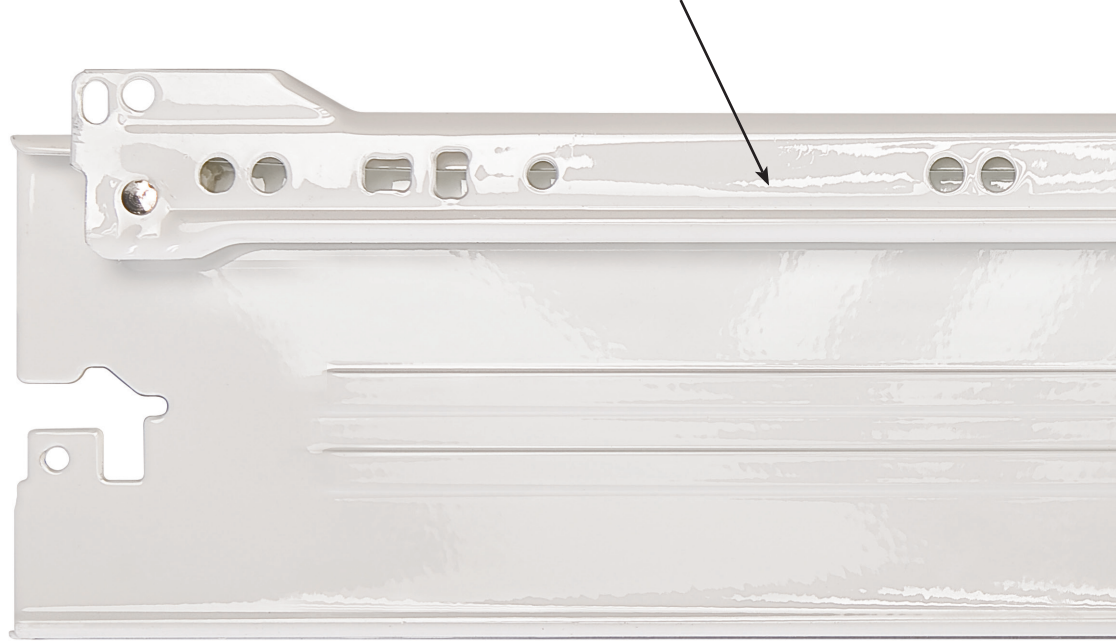

32mm System

Height of drawer sides in 32mm increments, makes cabinet design easy.

The Integra single-wall metal drawer system offers cabinet makers a variety of design options for modern kitchens and bathrooms.

Features

- Available in 2 drawer heights:
 - 85mm (3 3/8")
 - 149mm (5 7/8")

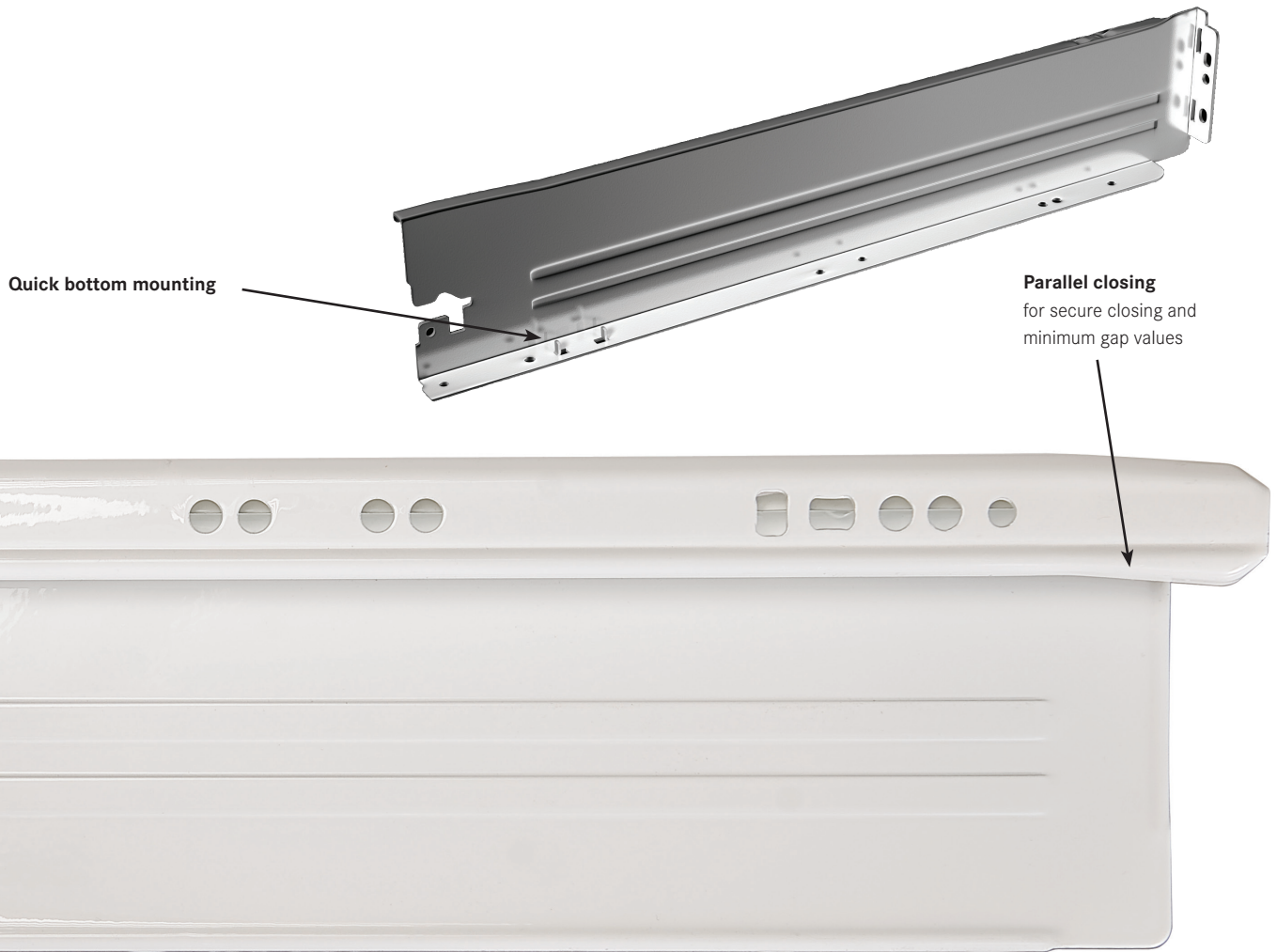

Interior Drawers

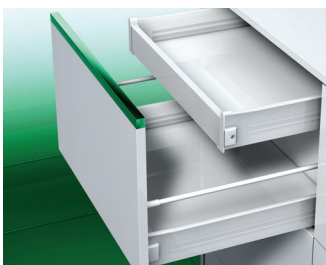

Tall Drawer Fronts

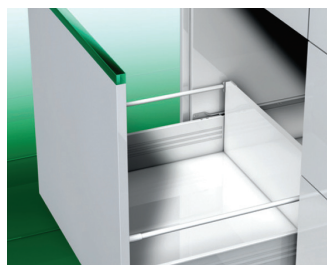

Hanging File Rail

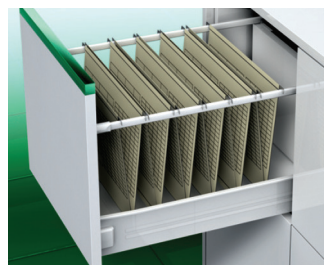

Quick Bottom Mounting

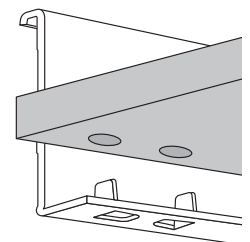

Technical Information

Integra

Cabinet Member Mounting Positions 32mm Grid

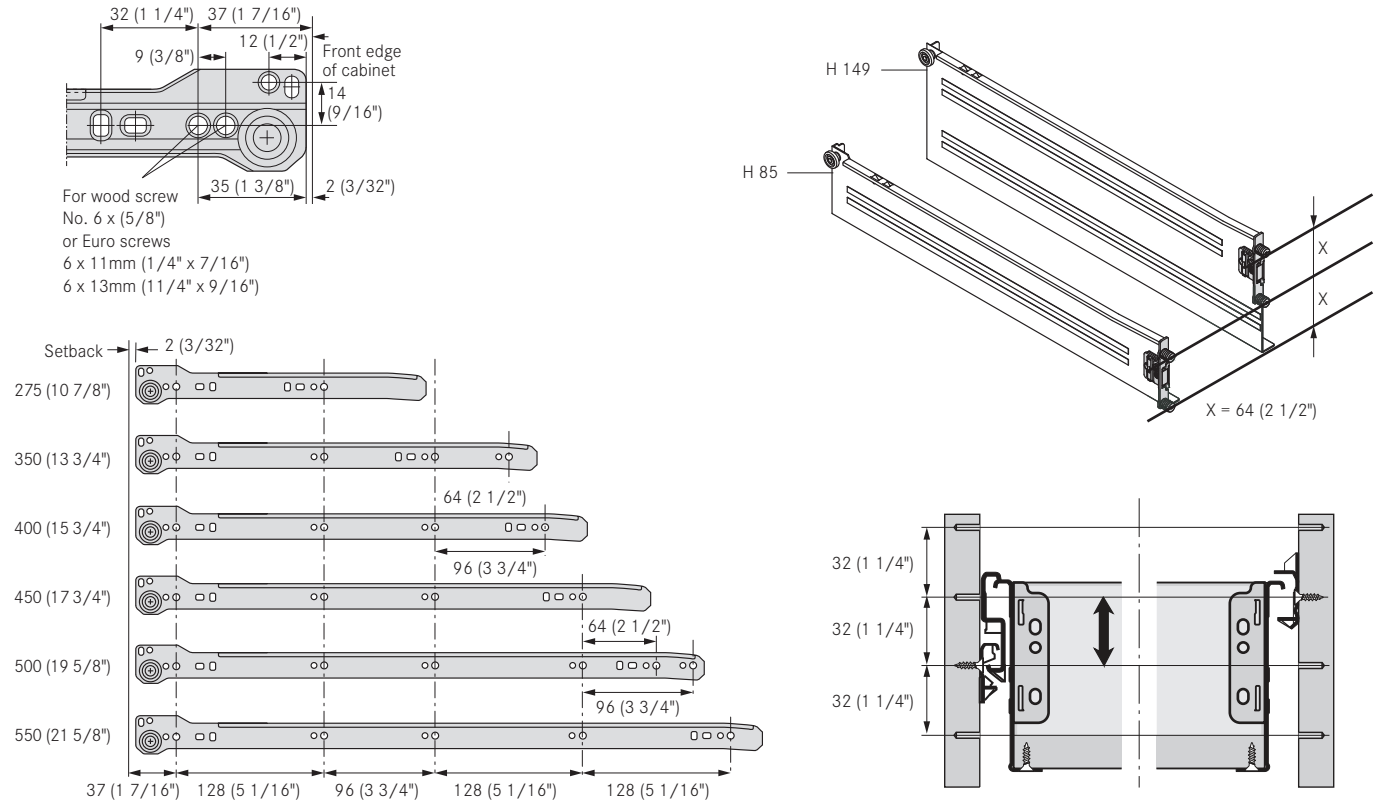

Minimum Gap

Minimum gaps are required due to parallel self-closing feature

Minimum gap for 19mm front = 0.5mm

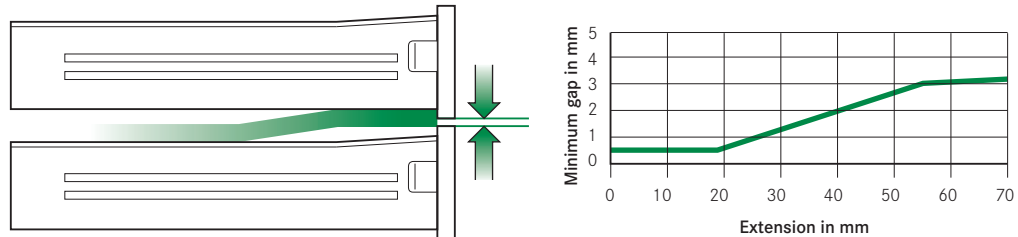

Removal Space

Small space necessary for insertion and removal "roller over axle"

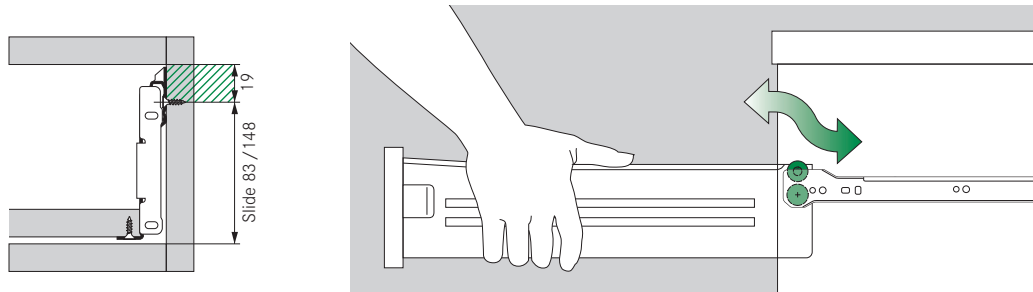

Weight Capacities per Pair of Slides

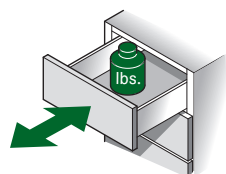

Integra: 100 lb dynamic load rating; 125 lb static load rating

Integra meets and exceeds the minimum requirements of ANSI/BHMA A156.9 standard, Grade 1

Drawer Front Attachment

Drawer Front Removal

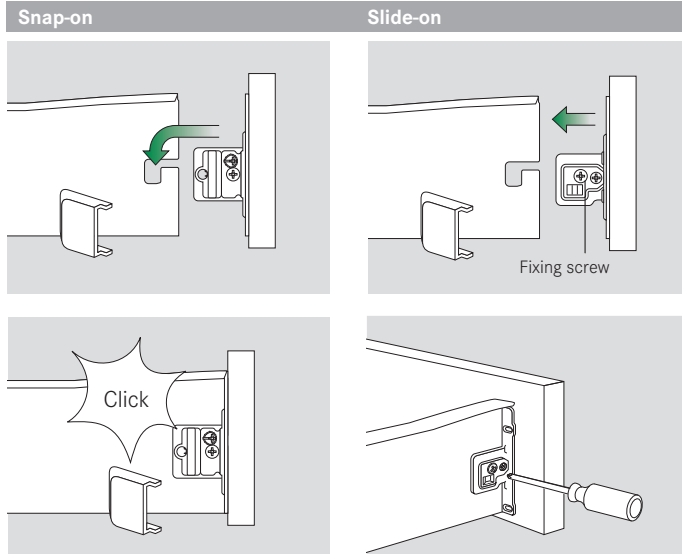

Snap-on

1. Insert front
2. Front clicks on automatically

Slide-on

1. Insert front
2. Tighten fixing screw

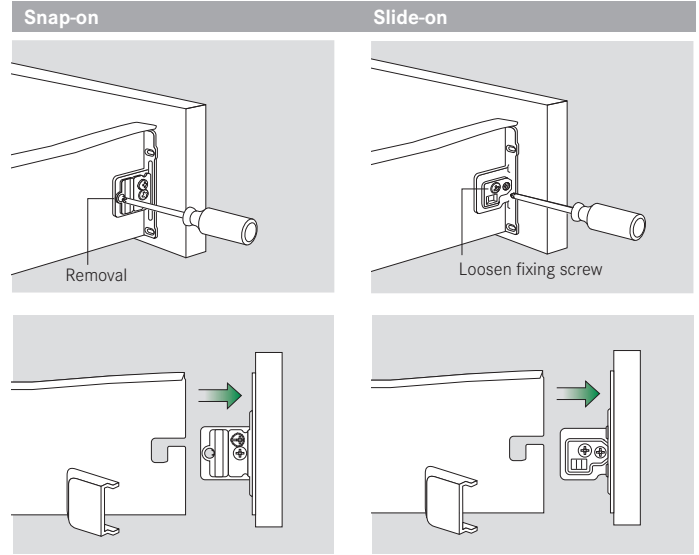

Snap-on

1. Loosen screw as indicated
2. Remove front

Slide-on

1. Loosen fixing screw
2. Remove front

Cam Height Adjustment

Integra Snap-on and Slide-on

Brackets will be supplied in neutral position. Therefore up and down adjustment is possible.

If adjustment is necessary:

1. Loosen fixing screw
2. Adjust cam
3. Tighten fixing screw

Slide-on

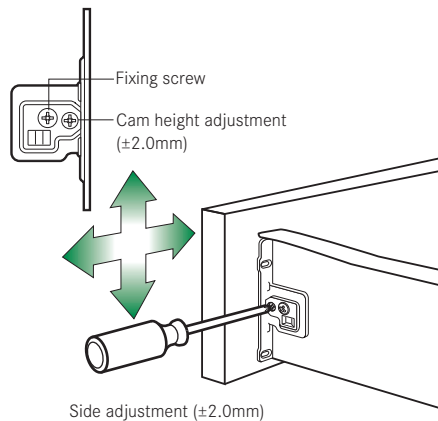

Snap-on

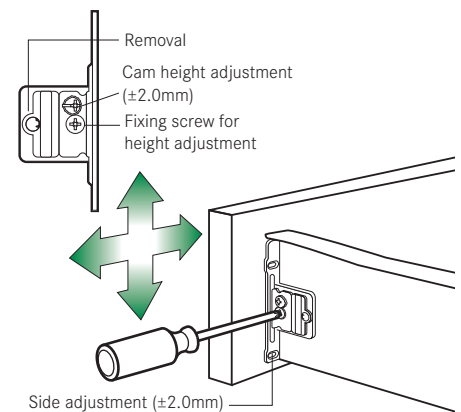

Mounting Tips

Front fixing bracket with press-in dowel

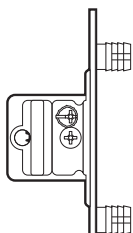

When using front fixing brackets with press-in dowel the bored holes should be countersunk. Hard surface coatings such as melamine can shear off the dowel membranes. This will result in a drastically reduced holding power of the front bracket.

For commercial applications we recommend using a close stop to prevent the drawer front from hitting the cabinet.

Integra Quick 9313

149mm (5 7/8") Side Height

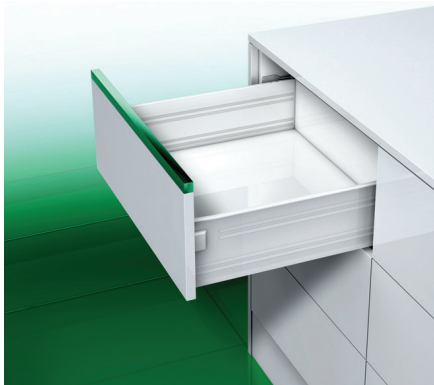

- Metal drawer system
- White baked on epoxy finish
- Single extension, height 149mm (5 7/8")
- Load capacity: 100 lb dynamic
- Installation width 15.5mm (5/8")
- Snap-on bottom mounting
- Made in the USA

Integra 9313 Slide, 100 lb (45 kg)



Description	Nominal Length	Item No.	PU
Integra 9313/350	350 (14")	F084075187204	5
Integra 9313/400	400 (16")	9313.400.2.U	5
Integra 9313/450	450 (18")	9313.450.2.U	5
Integra 9313/500	500 (20")	9313.500.2.U	5
Integra 9313/550	550 (22")	9313.550.2.U	5

Front Fixing Brackets



Description	Left Hand Item No.	Right Hand Item No.	PU
(Must order separately)			
1 Snap-on, dowel	9306.L.VE10	9306.R.VE10	10
Snap-on, dowel	F084075178236	F084075179236	250
2 Slide-on, dowel	9206.L.VE10	9206.R.VE10	10
Slide-on, dowel	F084115234536	F084115235536	250
For additional front fixing brackets see page 51			
3 Cover Cap		F084075011111	20

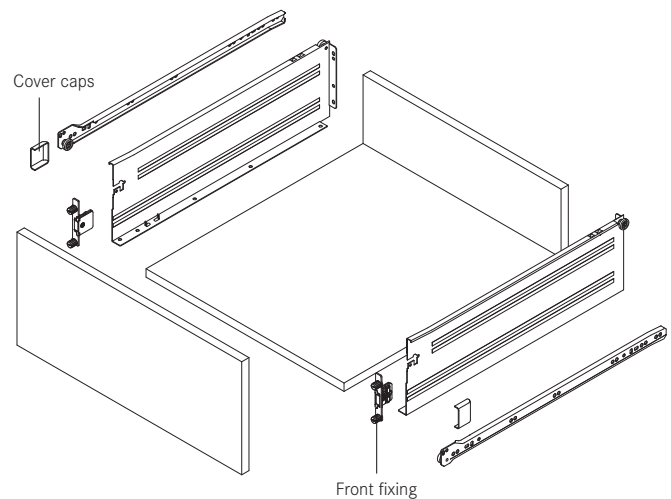

PU - Packaging unit

Drawer Back and Bottom Measurements

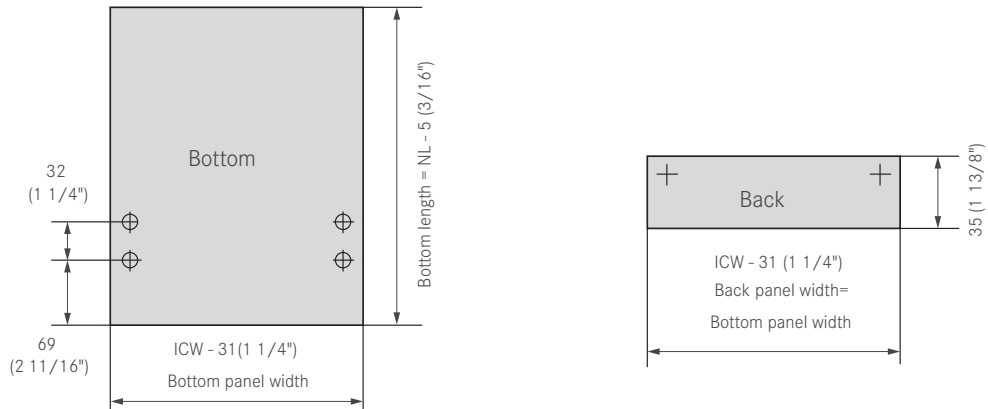

Drawer Measurements

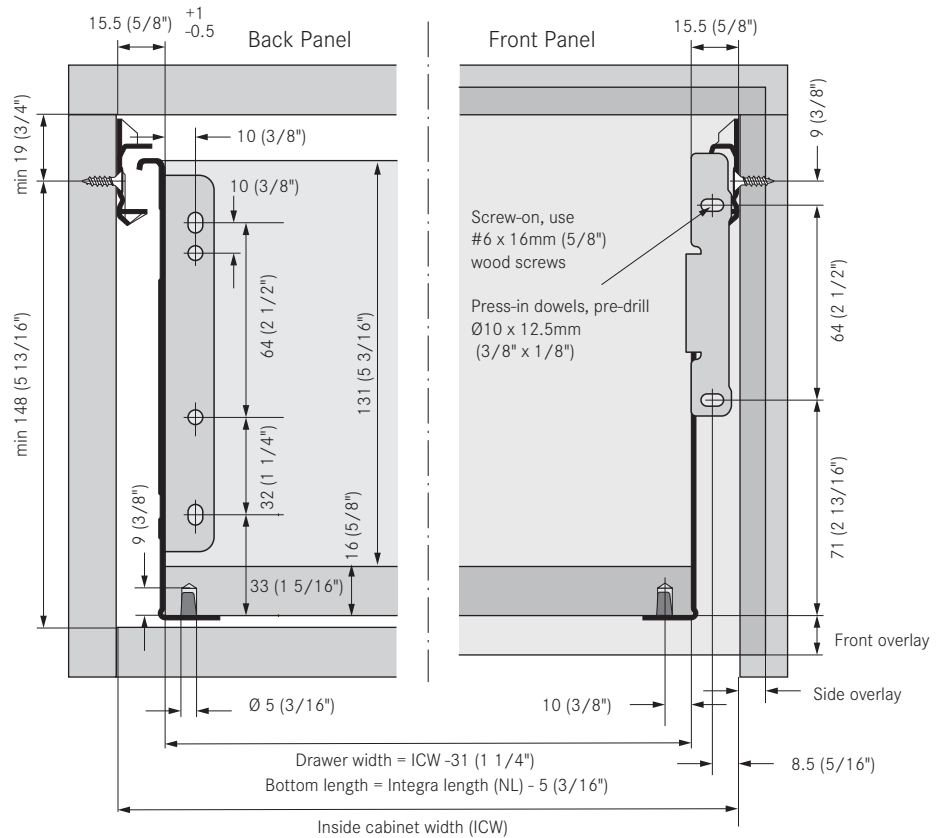

ICW = inside cabinet width
 IDW = inside drawer width
 NL = nominal length

Integra Quick 9113

85mm (3 3/8") Side Height

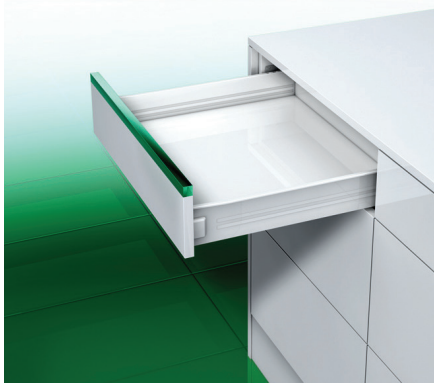

- Metal drawer system
- White baked on epoxy finish
- Single extension, height 85mm (3 3/8")
- Load capacity: 100 lb dynamic
- Installation width 15.5mm (5/8")
- Snap-on bottom mounting

Integra 9113 Slide, 100 lb (45 kg)



Description	Nominal Length	Item No.	PU
Integra 9113/350	350 (14")	F084075017207	10
Integra 9113/400	400 (16")	F084075020207	10
Integra 9113/450	450 (18")	F084074990207	10
Integra 9113/500	500 (20")	F084074993207	10
Integra 9113/550	550 (22")	F084075025207	10

Front Fixing Brackets



Description	Left Hand Item No.	Right Hand Item No.	PU
(Must order separately)			
1 Snap-on, dowel	9306.L.VE10	9306.R.VE10	10
Snap-on, dowel	F084075178236	F084075179236	250
2 Slide-on, dowel	9206.L.VE10	9206.R.VE10	10
Slide-on, dowel	F084115234536	F084115235536	250
For additional front fixing brackets see page 51			
3 Cover Cap		F084075011111	20

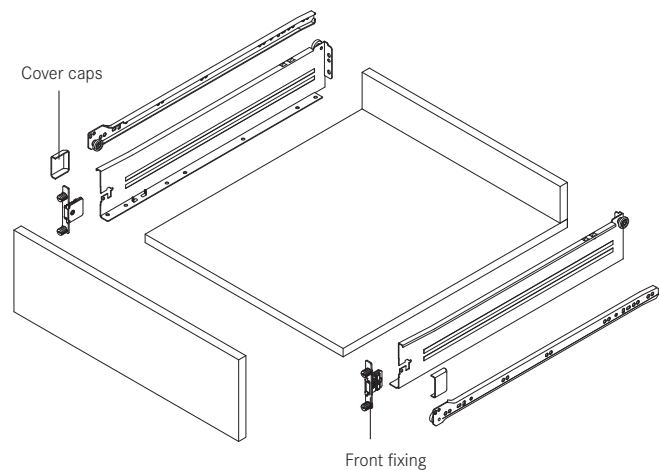

PU - Packaging unit

Drawer Back and Bottom Measurements

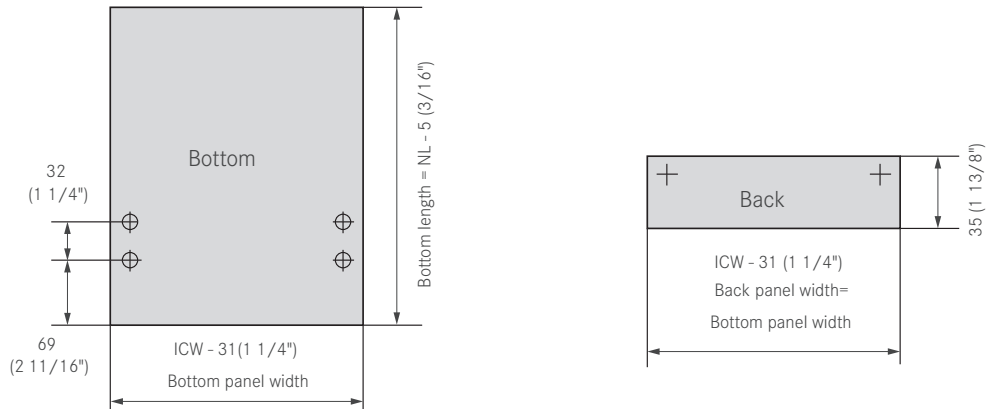

Drawer Measurements

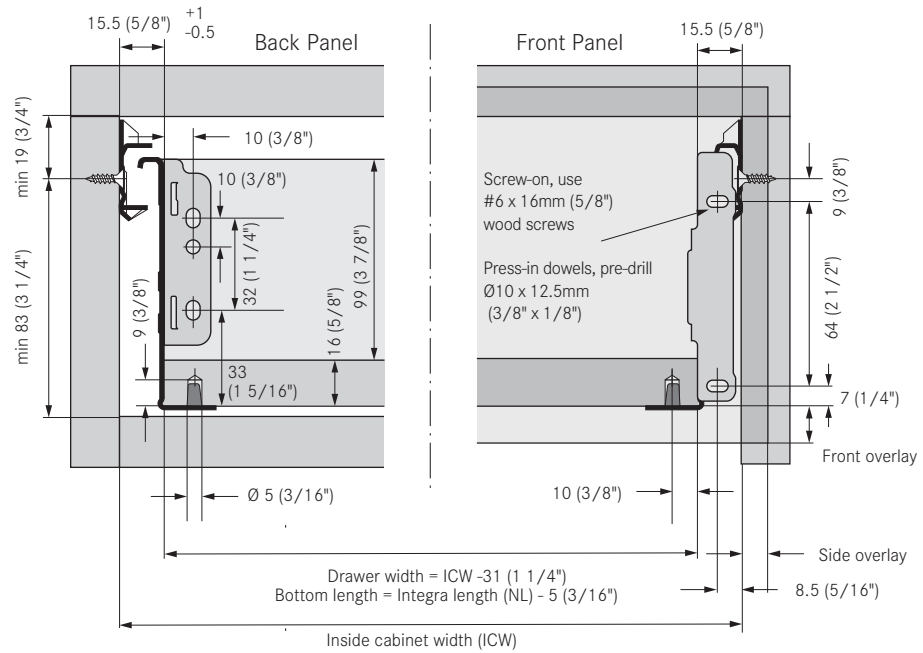

ICW = inside cabinet width
 IDW = inside drawer width
 NL = nominal length

Integra Soft-close

Damper set

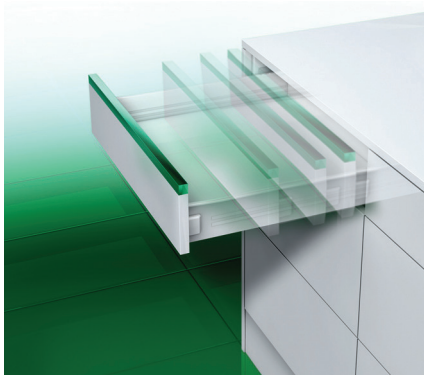

- Add-on damper creates a smooth soft-close action
- Liquid damper for improved performance
- Three options for various load capacities
- Height adjustment $\pm 2\text{mm}$ via elongated hole
- Secure striker plate engagement
- Actuator design allows for flush mounting
- Set includes: damper and actuator unit

Soft-close Damper

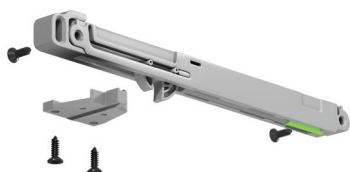

Description	Load Capacity	Item No.	PU
15 kg Damper set	33 lb	02564-11	140
30 kg Damper set	66 lb	02572-11	140
70 kg Damper set	154 lb	02565-11	140

Note: Damper sets do not include screws.

Soft-close Damper Placement



Dampers per Drawer

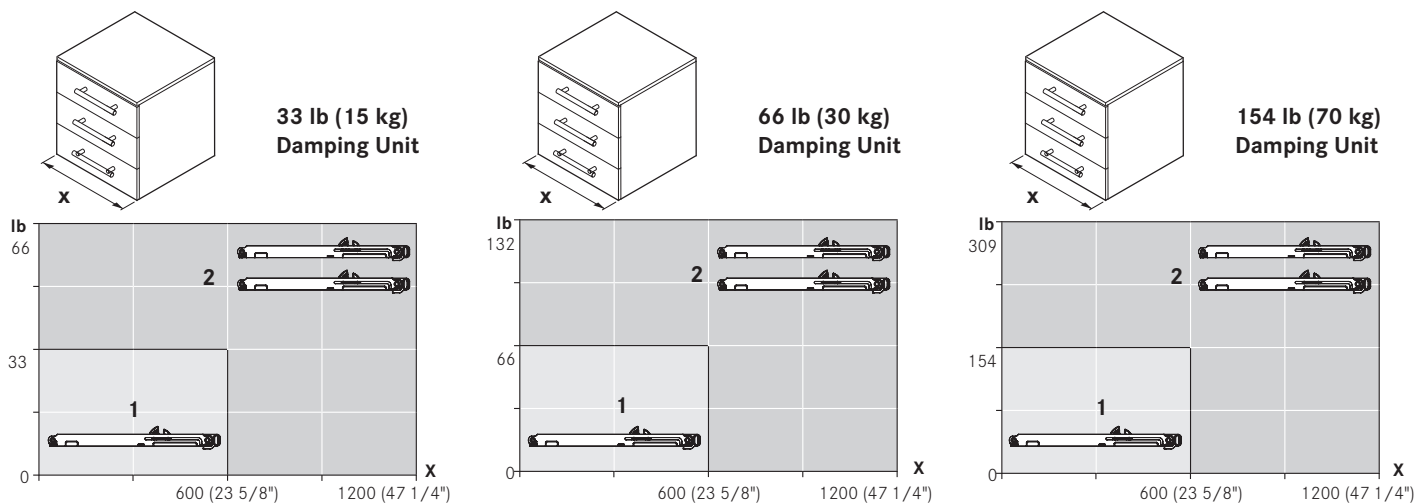

PU - Packaging unit

Product specifications

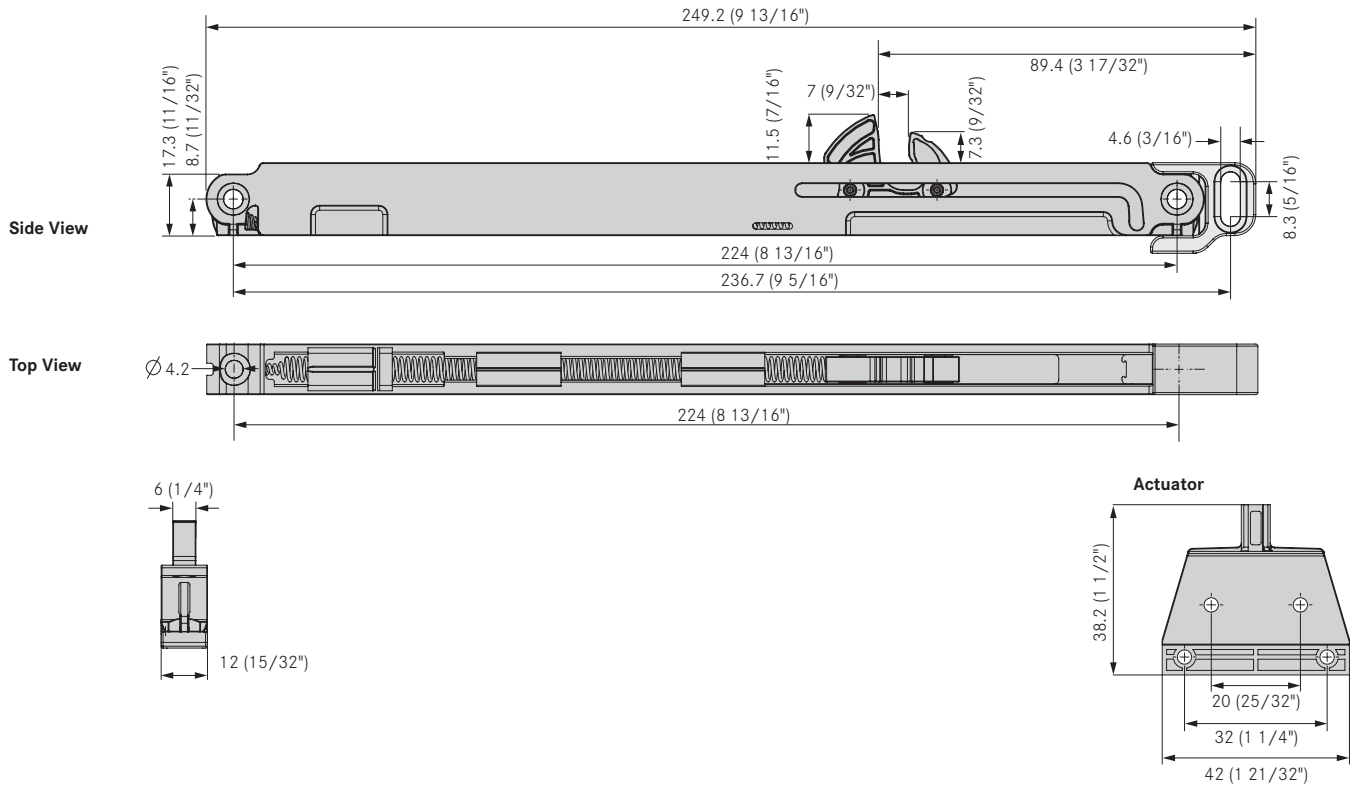

Mounting dimensions

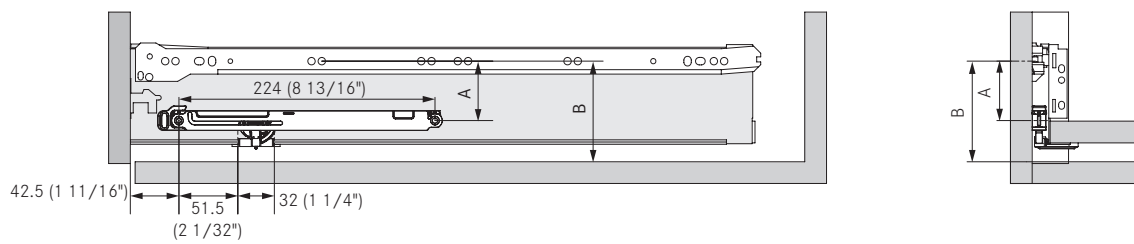

Recommended screws are:

#4 x 1/2" Phillips flat head wood screws

#4 x 3/4" Phillips pan head wood screws

Integra	A	B
85	62	88
149	120	152

Roller Slide 1700/1702

For Pull-out Shelf



- Single extension
- Load capacity: 100 lb dynamic
- Installation width 12.5mm
- Bottom mount slide
- Nylon rollers
- White baked on epoxy finish

1700/1702 Roller Slide, 100 lb (45 kg)



Description	Nominal Length	Item No.	PU
1700/300	300 (12")	1700.300.2	20
1700/350	350 (14")	1700.350.2	20
1700/400	400 (16")	1700.400.2	20
1700/450	450 (18")	1700.450.2	20
1700/500	500 (20")	1700.500.2	20
1700/550	550 (22")	1700.550.2	20
1702/300	300 (12")	F080073985213	25
1702/350	350 (14")	F080073988213	25
1702/400	400 (16")	F080073992213	25
1702/450	450 (18")	F080073995213	25
1702/500	500 (20")	F080073998213	25
1702/550	550 (22")	F080074001213	25

Cabinet Member Boring Specifications

Drawer Measurements

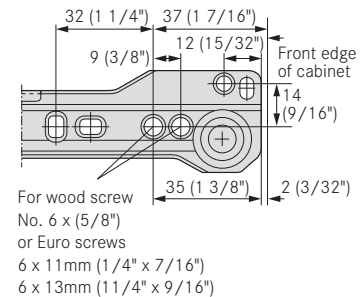
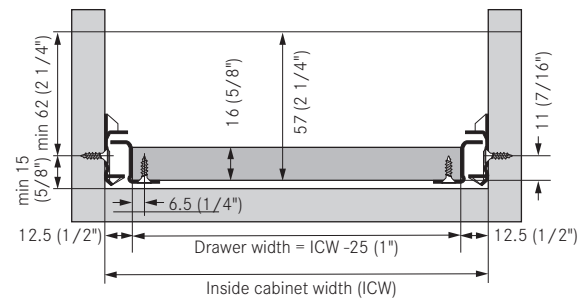
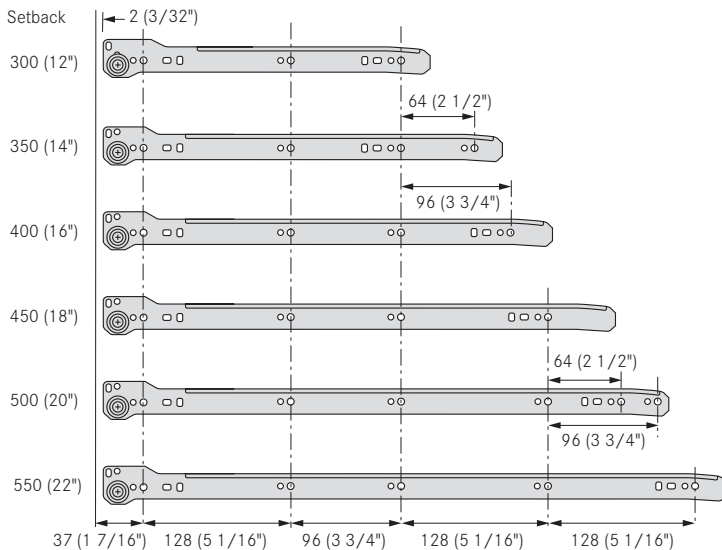

PU - Packaging unit

Integra Interior Drawer

Front Fixing Adapters

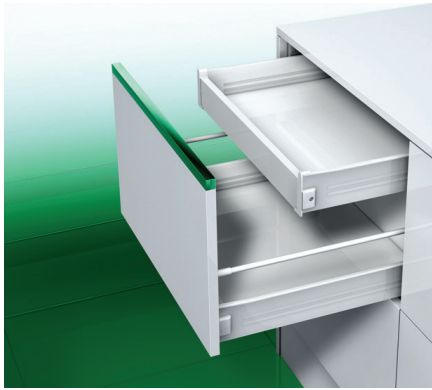

- Front fixing adapters for interior drawers
- For 85mm drawer height
- White
- Screw-on

Front Fixing Adapter 9108



Description	Height	Item No.	PU
Front fixing adapter 9108	85mm (3 3/8")	F084074983107	10

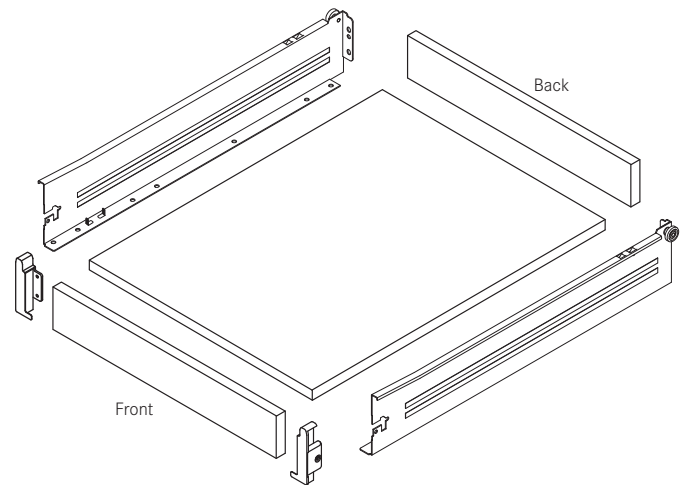

Drawer Back, Bottom and Front Measurements

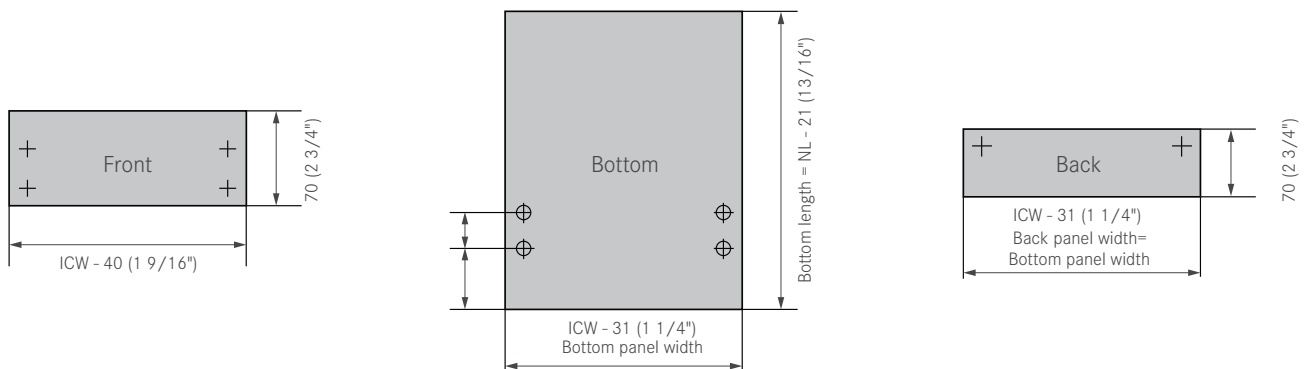

Integra Adjustable Gallery Rail 3500

For Screw-on front fixing

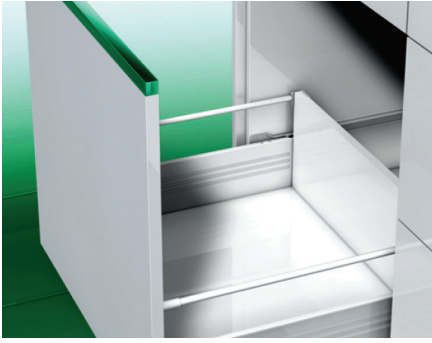

- For Integra drawers with tall fronts and tall wooden drawer backs
- Color: white

3500 Railing System

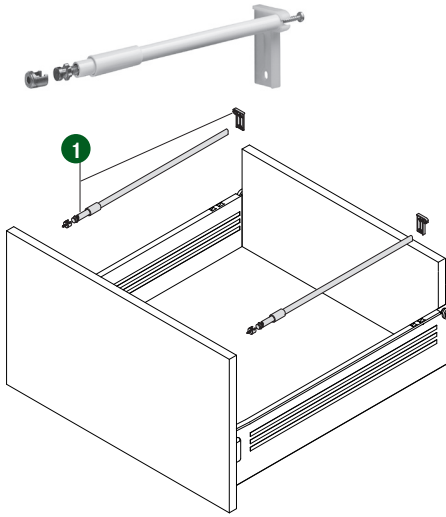

Description	Drawer Length	Item No.	PU
1 Gallery Railing Set	500 (20")	F084074811511	20

File Railing set consists of:

- 2 Side gallery rails
- 2 Front fixing parts
- 2 Back fixing parts
- 2 Cover caps

Installation Instructions

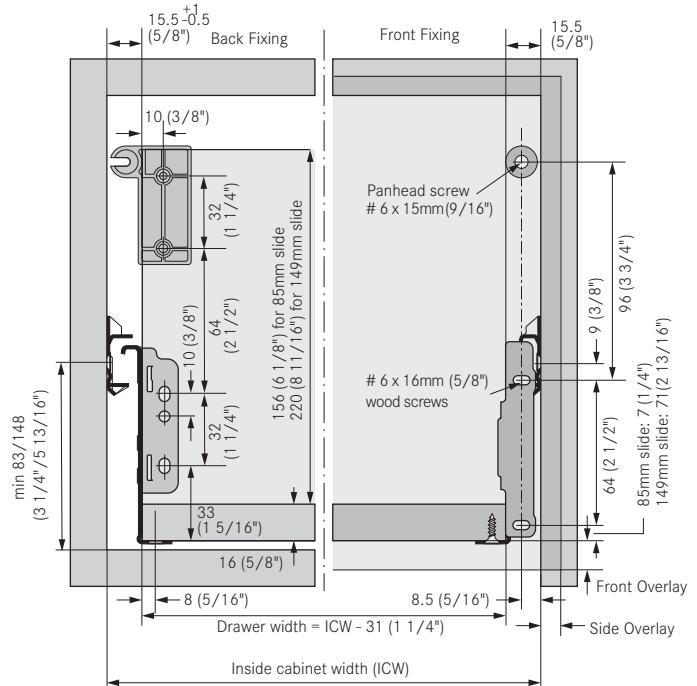
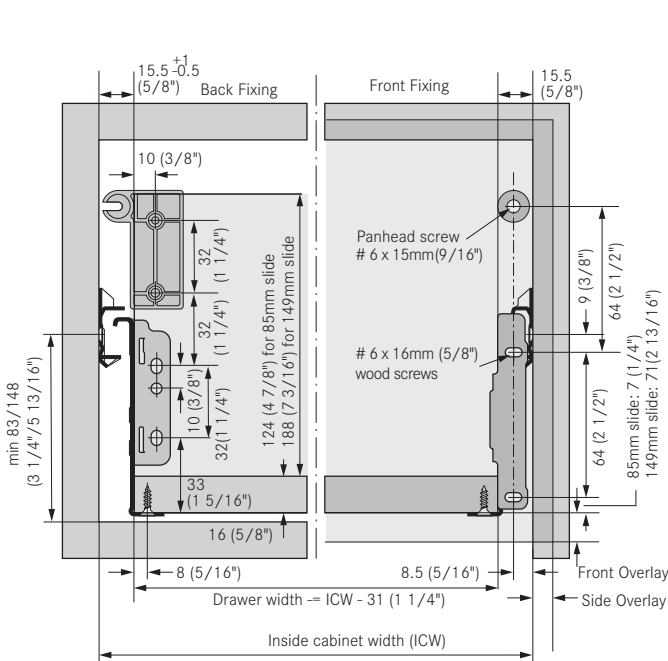

PU - Packaging unit

3595 Aluminum File Rail



For Integra

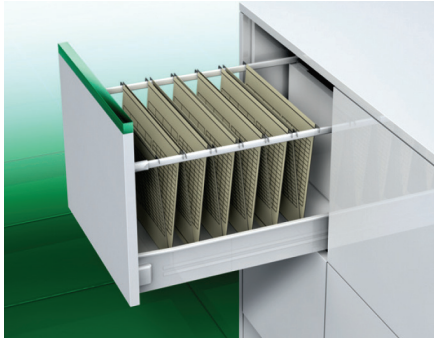

- Keep hanging files organized
- Install file railing system independent from drawer system
- Front tilt adjustment
- Oval aluminum anodized

3595 Railing System

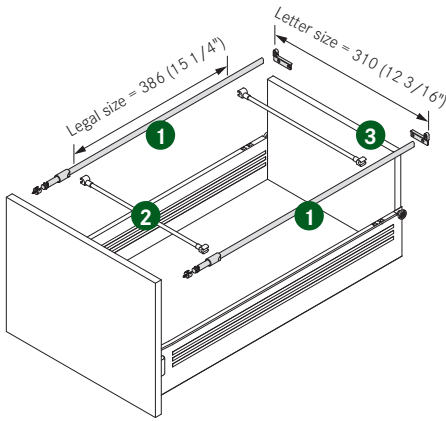

Description	Length	Item No.	PU
1 File Railing Set	500 (20")	F084074850511	20
File Railing Set	550 (22")	F084074851511	20
2 Divider Rail - cut to size	1200 (47 1/4")	F084074854223	20
3 Divider Clips		F084074857133	20

File Railing set consists of:

- 2 Side gallery rails
- 2 Front fixing parts
- 2 Back fixing parts
- 2 Cover caps

Front Tilt Adjustment

Back and Bottom Measurements

Installation Instructions

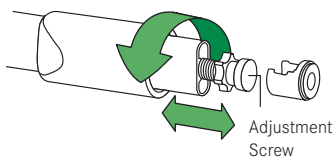

Adjustment Screw

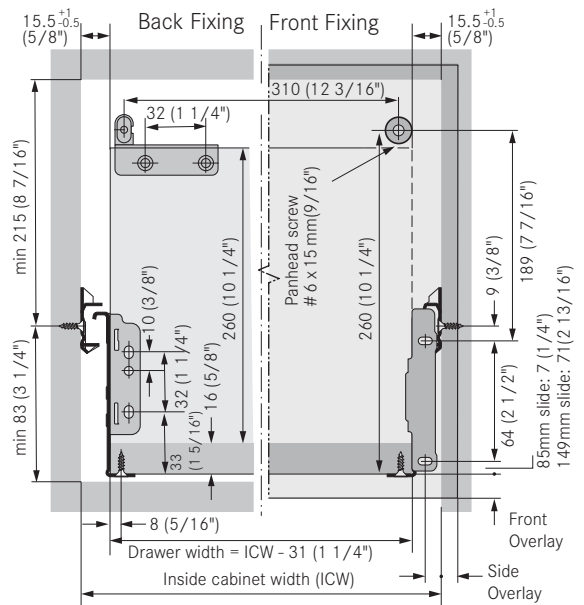
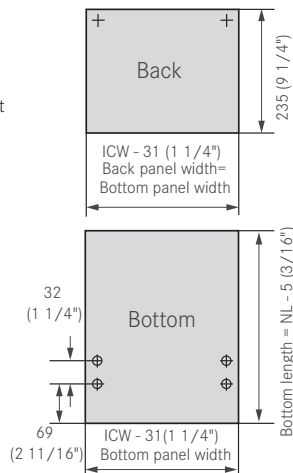

PU - Packaging unit

Accessories

Integra

Integra/1700/1702 Drill Jig



- For pre-drilling the cabinet member position.
- For Integra and 1700/1702
- Also works for 1754 and 1800 Roller slide

Description	Item No.	PU
1700/1702 Drill Jig	F146083248 101	1

3810/3811 Close Stop



- For Integra single extension
- Ensures 1.5mm (1/16") or 3mm (1/8") gap between front and cabinet.
- Assembles at back panel left and right.

Description	Item No.	PU
3810 Close stop, 1.5mm	F084117240 547	100
3811 Close stop, 3mm	F084074897 123	100

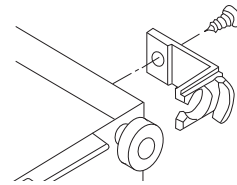

Spacer for Cabinet Members



To provide side clearance for interior drawers and pull-out shelves.



Description	Item No.	PU
1 3800 Spacer, symmetrical, 25mm	F084074894 123	100
2 3802 Spacer/pin, asymmetrical, 25mm	F084074895 123	100
3 6195 Spacer, 11mm	89104-39	20

3800 Installation Instructions

3802 Installation Instructions

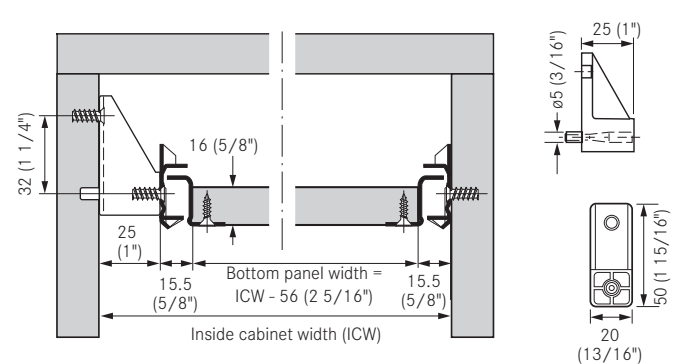
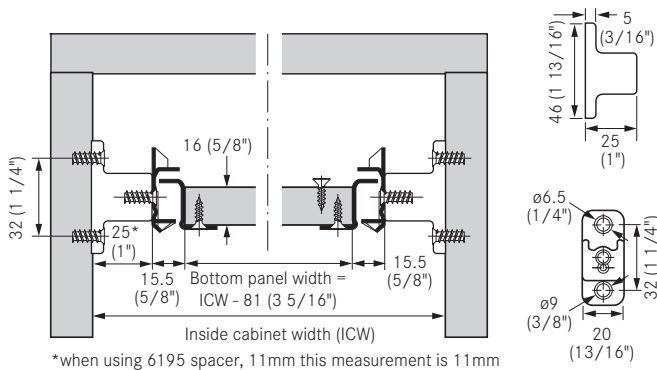

PU - Packaging unit

Integra

Snap On Front Fixing Brackets for 9113/9213/9313



Description	Type	Left Hand Item No.	Right Hand Item No.	PU
Snap-on front fixing bracket	Screw-on	F084115240 107	F084115242 107	10
Snap-on front fixing bracket	Press-in dowel	9306.L.VE10	9306.R.VE10	10
Snap-on front fixing bracket	Screw-on	F084115240 236	F084115242 236	250
Snap-on front fixing bracket	Press-in dowel	F084075178 236	F084075179 236	250

Slide On Front Fixing Brackets for 9113/9213/9313



Description	Type	Left Hand Item No.	Right Hand Item No.	PU
Slide-on front fixing bracket	Screw-on	F084115230 107	F084115232 107	10
Slide-on front fixing bracket	Press-in dowel	9206.L.VE10	9206.R.VE10	10
Slide-on front fixing bracket	Screw-on	F084115231 236	F084115233 236	250
Slide-on front fixing bracket	Press-in dowel	F084115234 536	F084115235 536	250

Universal Rear Mounting Socket, 4"

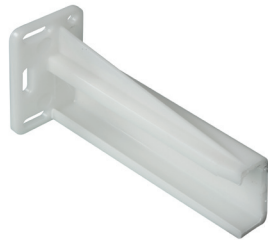

- Drawer slide can slide in or out to achieve different cabinet depth
- Extra long length
- Socket can be stapled or screwed

Description	Item No.	PU
Rear mounting socket, 4", Left	931.248.00.0249	500
Rear mounting socket, 4", Right	931.248.00.0149	500

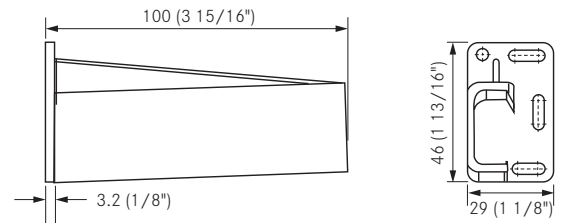

Rear Mount Socket for 1700/1702



- Drawer slide can slide in or out to achieve different cabinet depth
- Socket can be stapled or screwed

Description	Item No.	PU
Rear mounting socket, 1700/1702, Left	499.217.00.0249	500
Rear mounting socket, 1700/1702, Right	499.217.00.0149	500

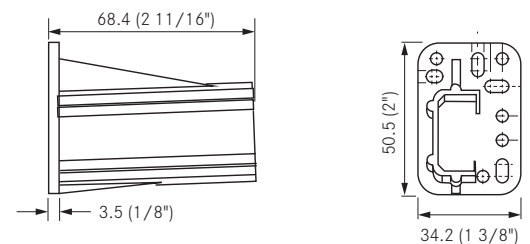



GRASS America Inc.
1202 NC Highway 66 South
Kernersville, NC 27284

Phone: 1-800-334-3512
Fax: 1-800-525-8406

Website: www.grassusa.com
E-mail: info@grassusa.com

GRASS Canada Inc.
10 Newgale Gate, Unit 7
Toronto, ON M1X 1C5

Phone: 1-800-461-4975
Fax: 1-416-335-5907

Internet: www.grasscanada.com
E-Mail: info@grasscanada.com



www.grassusa.com