



NOVA PRO

G*GRASS®

NOVA PRO DRAWER SYSTEM

The elegant double-wall drawer system that offers innovative functionality, timeless design and maximum efficiency.







The tried and tested Nova Pro Drawer System offers outstanding quality, maximum design freedom and innovative functional solutions for modern cabinet construction.

Stylish design with a variety of options

The designer inspired Nova Pro is a double-walled, steel drawer system concealing a full extension slide that not only glides with precision, but provides a high load capacity. A system engineered to exceed industry standards for weight capacity and longevity. From traditional to modern to everywhere in between, Nova Pro offers a beautiful metallic finish that enhances all kitchen designs. Sleek contoured sides with interior vertical walls are designed to provide maximum interior storage. Deep drawers can be created with Nova Pro's tall side and side rails. Nova Pro offers the ever-popular Soft-close action and can be outfitted with the Sensomatic, electro-mechanical opening system for handle free drawers.



NOVA PRO DRAWER SYSTEM

Sophisticated. Intelligent. Advanced.
The classic double-wall Nova Pro drawer system offers maximum functionality, timeless design, and outstanding aesthetic appeal. From the slide to the add-on rails to the electronic opening system you can see why Nova Pro reigns supreme.



A place for everything and everything in its place

Whether it's food items, beverages, or kitchen utensils, everything can be stored neatly away and instantly retrieved. With Nova Pro's railing and divider system this task is easier than ever. And all Nova Pro organization is designed to your specification.



Engineered to the highest standards

Synchronized full-extension drawer slides give a superb gliding action for today's Nova Pro. This mechanical synchronization of each individual slide ensures enhanced comfort and movement without annoying sounds or resistance. And the operating function of Nova Pro remains unchanged even when moving heavy loads of up to 154 lb. Abrasion-resistant nylon rollers ensure smooth and even operation.

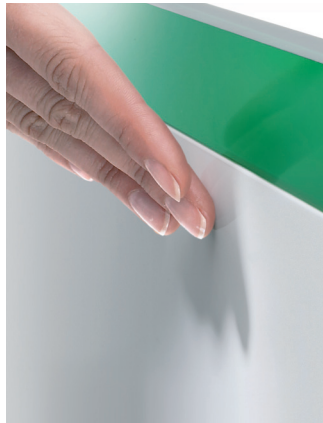

Sensomatic for opening and closing comfort

With the addition of Sensomatic, the electronic opening system, it becomes possible to create large, handle-free drawers that open with a gentle push on the drawer front. And Nova Pro features a liquid damper Soft-close technology for an even smoother closing action. Soft-close gently slows the drawers and pulls them to the fully closed position.

The exclusive rack and pinion mechanism synchronizes the telescoping cabinet profile for smooth extension and reduced side play.



Stylish design with a variety of options

From traditional to modern and every where in between Nova Pro offers a beautiful metallic finish that enhances all kitchen designs. Sleek contoured sides with vertical interior walls designed to provide maximum interior storage. Deep drawers can be created with Nova Pro's tall sides and side rails.

Table of Content

	Description	Adjustment	Page
	Features and Benefits		6
	Technical Information		8
	Standard Drawer P920 Series <ul style="list-style-type: none"> • Height 90 mm (3 1/2") • Integrated 2-dimensional adjustment • Soft-close 	<ul style="list-style-type: none"> • Height adjustment $\pm 2.0\text{mm}$ via cam • Side adjustment $\pm 1.5\text{mm}$ 	10
	Standard Drawer with Railings P920 Series <ul style="list-style-type: none"> • Height 90 mm (3 1/2") • Integrated 2-dimensional adjustment • Soft-close 	<ul style="list-style-type: none"> • Height adjustment $\pm 2.0\text{mm}$ via cam • Side adjustment $\pm 1.5\text{mm}$ 	12
	Interior Drawer P920 Series <ul style="list-style-type: none"> • Height 90 mm (3 1/2") • Integrated 2-dimensional adjustment • Soft-close 	<ul style="list-style-type: none"> • Height adjustment $\pm 2.0\text{mm}$ via cam • Side adjustment $\pm 1.5\text{mm}$ 	14
	Interior Drawer with Railings P920 Series <ul style="list-style-type: none"> • Height 90 mm (3 1/2") • Integrated 3-dimensional adjustment • Soft-close 	<ul style="list-style-type: none"> • Height adjustment $\pm 2.0\text{mm}$ via cam • Side adjustment $\pm 1.5\text{mm}$ • Tilt adjustment $\pm 2.0\text{mm}$ 	16
	Deep Drawer P930 Series <ul style="list-style-type: none"> • Height 122 mm (4 3/4") • Integrated 3-dimensional adjustment • Soft-close 	<ul style="list-style-type: none"> • Height adjustment $\pm 2.0\text{mm}$ via cam • Side adjustment $\pm 1.5\text{mm}$ • Tilt adjustment $\pm 2.0\text{mm}$ 	18
	Deep Drawer with Railings P930 Series <ul style="list-style-type: none"> • Height 122 mm (4 3/4") • Integrated 3-dimensional adjustment • Soft-close 	<ul style="list-style-type: none"> • Height adjustment $\pm 2.0\text{mm}$ via cam • Side adjustment $\pm 1.5\text{mm}$ • Tilt adjustment $\pm 2.0\text{mm}$ 	20
	File Railing <ul style="list-style-type: none"> • Complements Nova Pro Metallic finish • File railing system is independent from drawer system 		22
	Accessories <ul style="list-style-type: none"> • Drawer stabilizer mechanism • Accessories • Tools 		23
	Sensomatic <ul style="list-style-type: none"> • Opening System for handle-free cabinets 		24

Features and Benefits

Nova Pro

Features



- Synchronized full-extension drawer slide
- Liquid damping system integrated into the cabinet member slows the momentum of the closing drawer
- 2 and 3-dimensional adjustment for perfect alignment
- Telescoping cabinet profiles provide a smooth extension and reduced side play
- Drawer front can be installed or removed without the use of tools
- Width of the bottom and back panel is the same

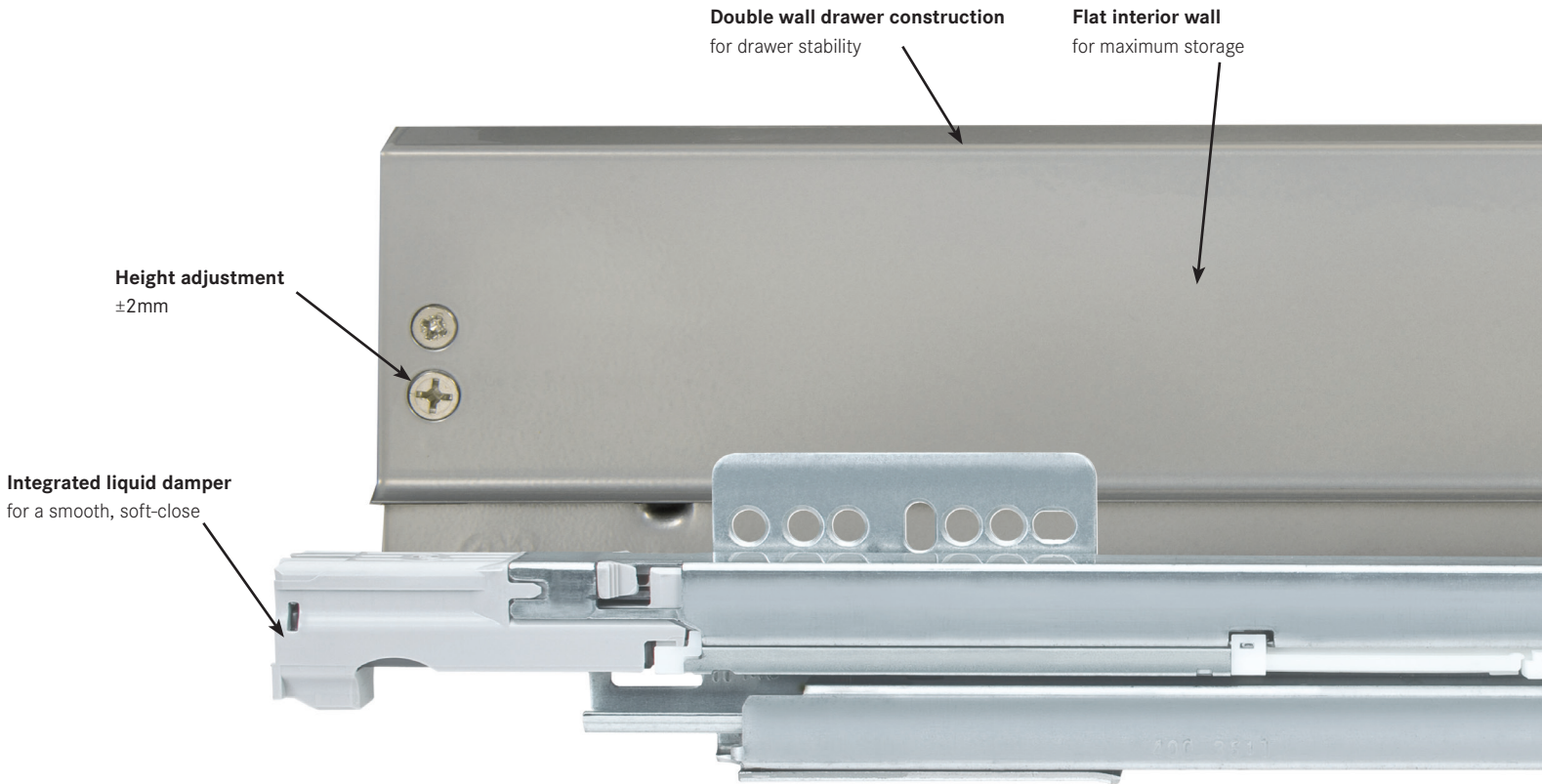

Double wall sides guarantee optimum lateral stability, synchronized movement and a smooth quiet running action.



Flat interior side walls provide maximum storage.

Features

- Vertical interior walls designed for maximum storage
- Available in Metallic finish
- Drawer side height of 90mm (3 1/2") and 122mm (4 3/4")
- High load carrying capacities of 88 lb and 154 lb
- Side and divider railings for personalized organization
- Tilt angle adjustment integrated in drawer slide for 122mm height

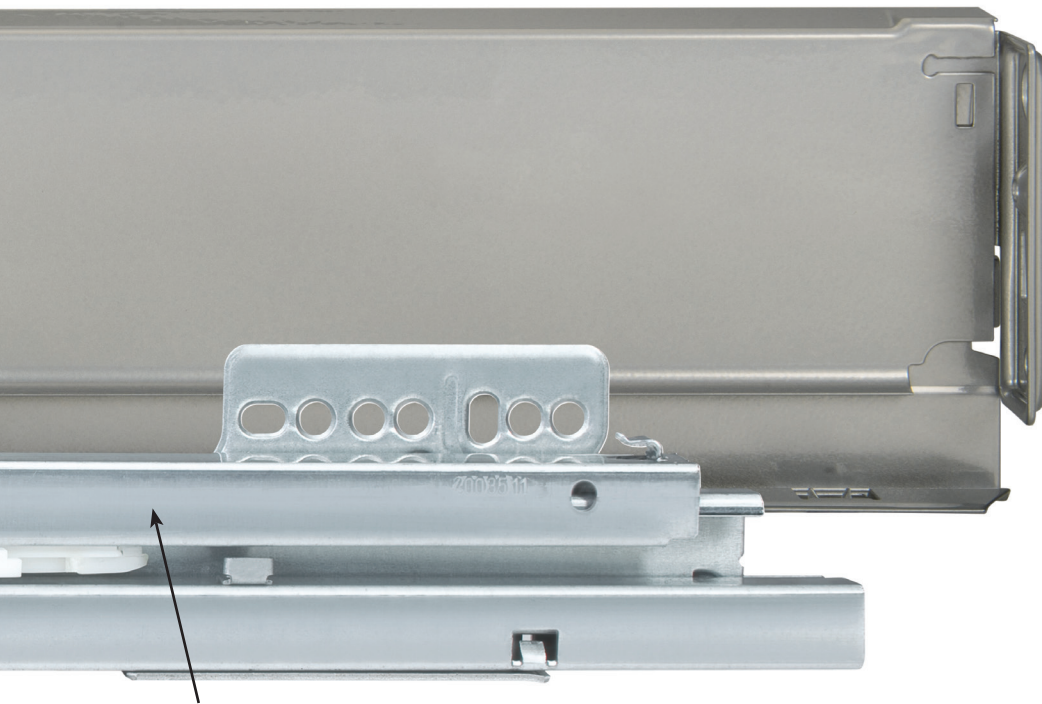

Telescoping cabinet member
provides smooth extension



Sensomatic
Innovative opening system for handle free drawers

Technical Information

Nova Pro

Installation and Removal



Drawer bottom can be secured in two ways:

1. By depressing barbed tabs with a manual punch
2. With wood screws



Front brackets are attached to the drawer front with screws or dowels. Position the drawer front in place, push down. Spring loaded catches secure the front to the drawer sides.



The Nova Pro drawers can be installed or removed with just one movement. No levers to press.

Side and Divider Railing Installation and Adjustment



Side railing and divider railing installation and removal are tool-free



Side railings provide tilt adjustment - tool-free or with screwdriver.



Dividers are moved by depressing the tabs on the end caps which index into holes underneath the side rails.

Weight Capacities per Pair of Slides

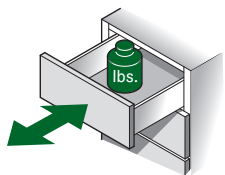

Nova Pro is available in two capacities: 88 lb and 154 lb dynamic load rating

Nova Pro meets and exceeds the minimum requirements of ANSI/BHMA A156.9 Standard, Grade 1

Drawer Front Assembly

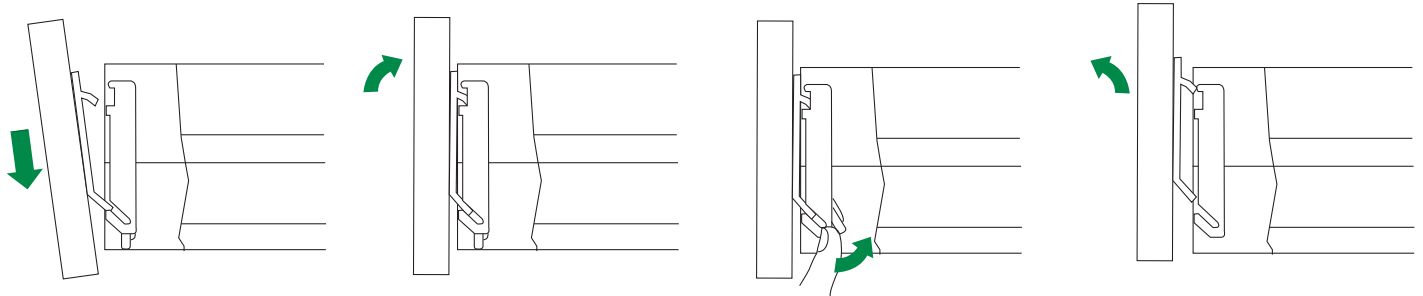

Front Assembly

1. Angle the front panel with the installation hooks into the lower slanted slot (0-positioning with the installation hooks).
2. Tilt the front in and...
3. Press down.

Front Removal

1. Press the catch
2. Remove front panel.

Height Adjustment with Eccentric Screw

Side Adjustment

H122 Front Tilt Angle Adjustment

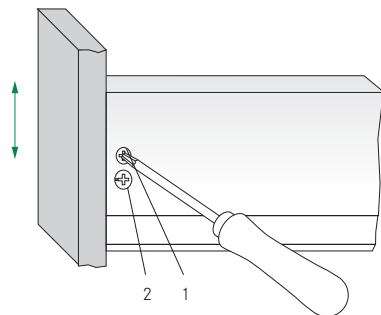

Height adjustment

- Slightly release screw 1 and move front to the desired height position using eccentric screw 2. Adjustment range $\pm 2\text{mm}$
- Tighten screw 1

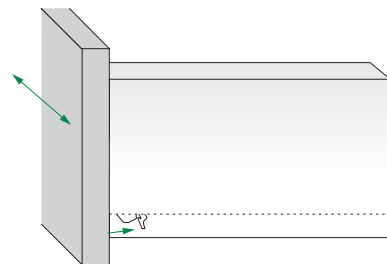

Side adjustment

- Slightly push clamping lever towards the back, lift front slightly and move across serration. Adjustment range $\pm 1.5\text{mm}$
- Release clamping lever

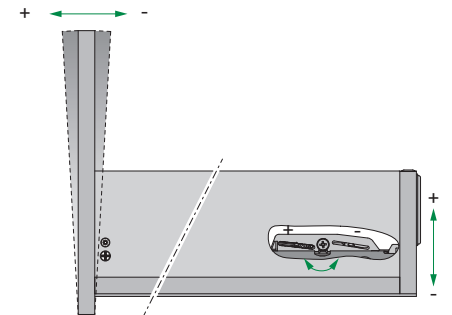

Tilt adjustment

For drawer side height 122

- Tilt adjustment is easily accessible on the inside of the drawer. Tilt angle adjustment is achieved by changing the position of the drawer. Adjustment range $\pm 2\text{mm}$

Nova Pro, Standard Drawer

P920 Series - 90mm (3 1/2") side height drawer system

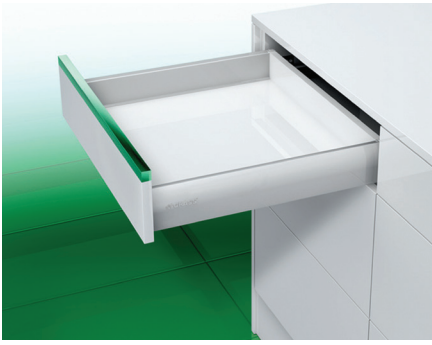

- The foundation drawer of the Nova Pro system
- Full extension for maximum access to drawer contents
- Available load capacities: 88lb (40kg) and 154 lb (70kg) dynamic
- Soft-close liquid damping system
- Tool-free drawer front removal and installation
- Cam height adjustment and tool-free side adjustment of drawer front
- Metallic finish

Cabinet Member Set and Drawer Member Set

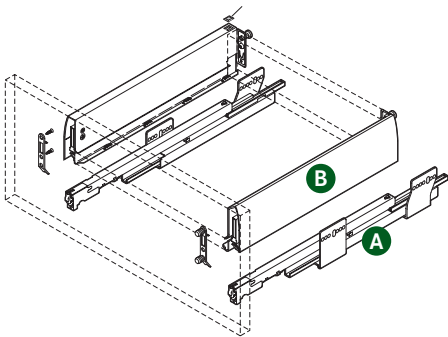

Description	Length	40kg (88 lb) capacity	70kg (154 lb) capacity	PU
A Nova Pro Cabinet Member Set	270 (11")	F101108261507	-	10
Nova Pro Cabinet Member Set	350 (14")	F101108267507	-	10
Nova Pro Cabinet Member Set	400 (16")	F101108270507	-	10
Nova Pro Cabinet Member Set	450 (18")	F101108273507	F101108285507	10
Nova Pro Cabinet Member Set	500 (20")	F101108276507	F101108288507	10
Nova Pro Cabinet Member Set	550 (22")	F101108279507	F101108291507	10

Description	Slide Length	Item No. Metallic	PU
B Nova Pro P920/270 Drawer Member Set	270 (11")	F100065000607	10
Nova Pro P920/350 Drawer Member Set	350 (14")	F100065006607	10
Nova Pro P920/400 Drawer Member Set	400 (16")	F100065009607	10
Nova Pro P920/450 Drawer Member Set	450 (18")	F100065012607	10
Nova Pro P920/500 Drawer Member Set	500 (20")	F100065015607	10
Nova Pro P920/550 Drawer Member Set	550 (22")	F100065018607	10

Brackets and Cover Cap

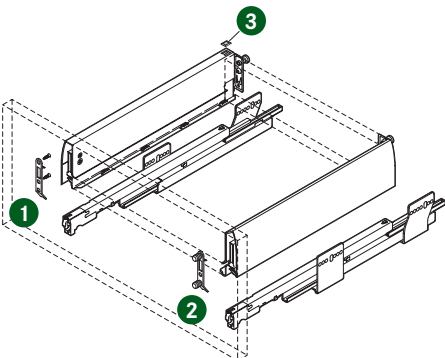

Description	Item No.	PU
1 Screw-on Bracket	F102021855547	100
2 Dowelled Bracket	F102021854123	100
3 U-cover cap	F102025821117	50

Note: Two brackets are required per drawer

PU - Packaging unit

Drawer Back and Bottom Measurements **Minimum Cabinet Depth**

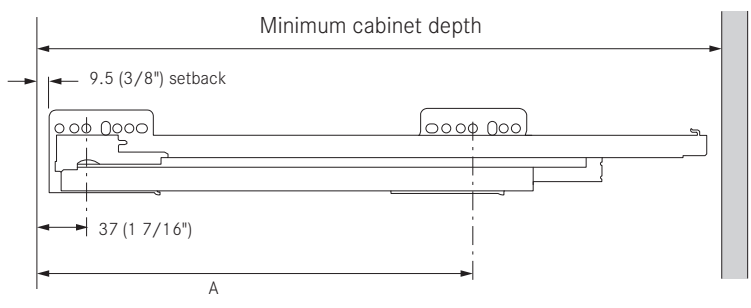
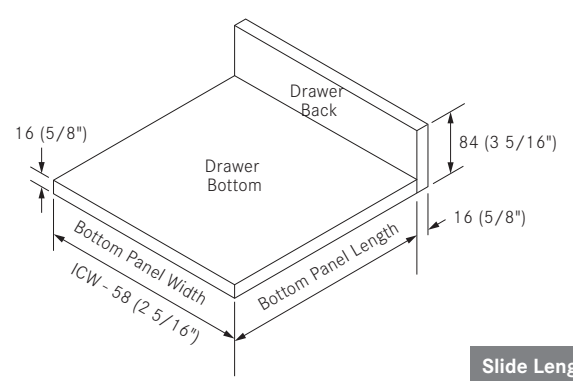

Attach with 13mm (1/2") long Euro screws or #7 X 5/8" wood screw.
Use 4 screws per side on 70kg (154 lb) slides.

Slide Length	Bottom Panel Length	A	Minimum Cabinet Depth
270 (11")	251 (9 7/8")	197 (7 3/4")	275 (10 13/16")
350 (14")	331 (13 1/16")	261 (10 9/32")	355 (14")
400 (16")	381 (15")	261 (10 9/32")	405 (15 15/16")
450 (18")	431 (16 15/16")	325 (12 13/16")	455 (17 15/16")
500 (20")	481 (18 15/16")	325 (12 13/16")	505 (19 7/8")
550 (22")	531 (20 7/8")	325 (12 13/16")	555 (21 7/8")

Drawer Installation Dimensions

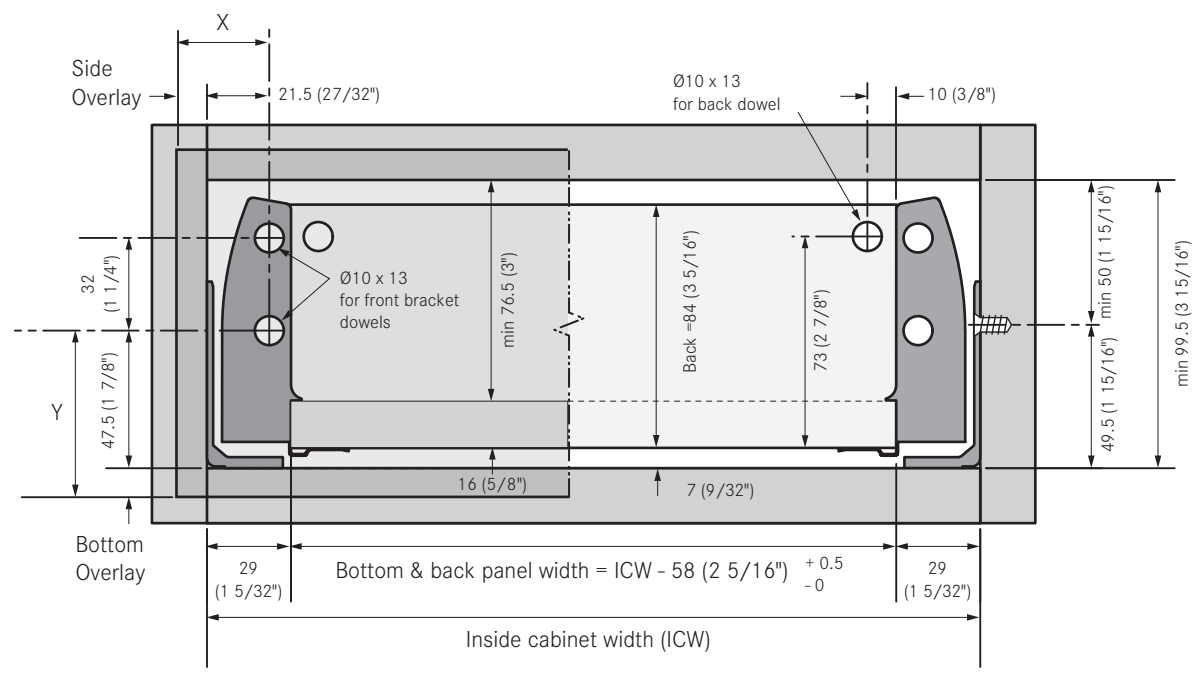

ICW = inside cabinet width

Nova Pro, Standard Drawer with Railings

P920 Series - 90mm (3 1/2") side height drawer system

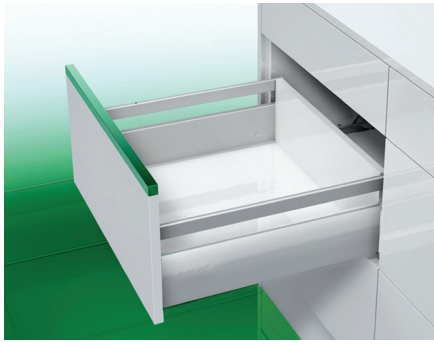

- Adding a railing set to the Standard Drawer increases height and enables organization with Nova Pro divider railing set
- Full extension for maximum access to drawer contents
- Available load capacities: 88lb (40kg) and 154 lb (70kg) dynamic
- Soft-close liquid damping system
- Tool-free drawer front, rail and divider removal and installation
- Cam height adjustment and tool-free side adjustment of drawer front
- Railings provide tilt adjustment of the drawer front
- Metallic finish

Cabinet Member Set and Drawer Member Set

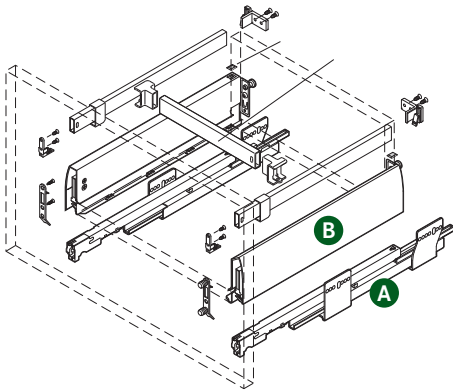

Description	Length	40kg (88 lb) capacity	70kg (154 lb) capacity	PU
A Nova Pro Cabinet Member Set	400 (16")	F101108270 507	-	10
Nova Pro Cabinet Member Set	450 (18")	F101108273 507	F101108285 507	10
Nova Pro Cabinet Member Set	500 (20")	F101108276 507	F101108288 507	10
Nova Pro Cabinet Member Set	550 (22")	F101108279 507	F101108291 507	10

Description	Slide Length	Item No. Metallic	PU
B Nova Pro P920/400 Drawer Member Set	400 (16")	F100065009 607	10
Nova Pro P920/450 Drawer Member Set	450 (18")	F100065012 607	10
Nova Pro P920/500 Drawer Member Set	500 (20")	F100065015 607	10
Nova Pro P920/550 Drawer Member Set	550 (22")	F100065018 607	10

Brackets, Cover Cap, and Railings

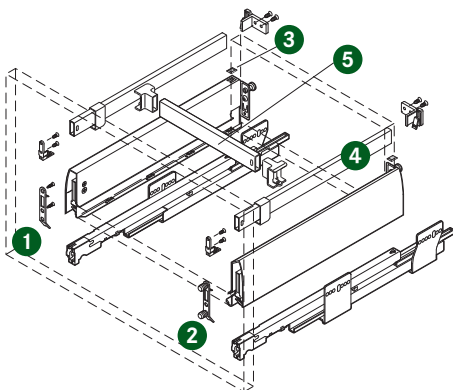

Description	Rail Length	Item No.	PU
1 Screw-on Bracket		F102021855 547	100
2 Dowelled Bracket		F102021854 123	100
3 U-cover cap		F10202582 1117	50
4 Side Railing set with tilt adjustment 400	400 (16")	F102045860 507	10
Side Railing set with tilt adjustment 450	450 (18")	F10204586 1507	10
Side Railing set with tilt adjustment 500	500 (20")	F102045862 507	10
Side Railing set with tilt adjustment 550	550 (22")	F102045863 507	10
5 Divider Railing set - cut to size	1200 (47 1/4")	F10205166 1507	5

Note: Two brackets are required per drawer

PU - Packaging unit

Drawer Back and Bottom Measurements

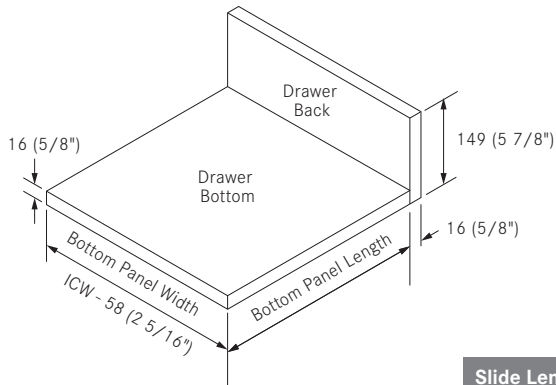

Minimum Cabinet Depth

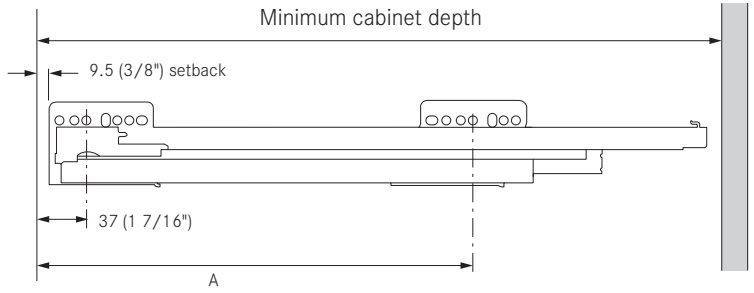

Attach with 13mm (1/2") long Euro screws or #7 X 5/8" wood screw.
Use 4 screws per side on 70kg (154 lb) slides.

Slide Length	Bottom Panel Length	A	Minimum Cabinet Depth
400 (16")	381 (15")	261 (10 9/32")	405 (15 15/16")
450 (18")	431 (16 15/16")	325 (12 13/16")	455 (17 15/16")
500 (20")	481 (18 15/16")	325 (12 13/16")	505 (19 7/8")
550 (22")	531 (20 7/8")	325 (12 13/16")	555 (21 7/8")

Drawer Installation Dimensions

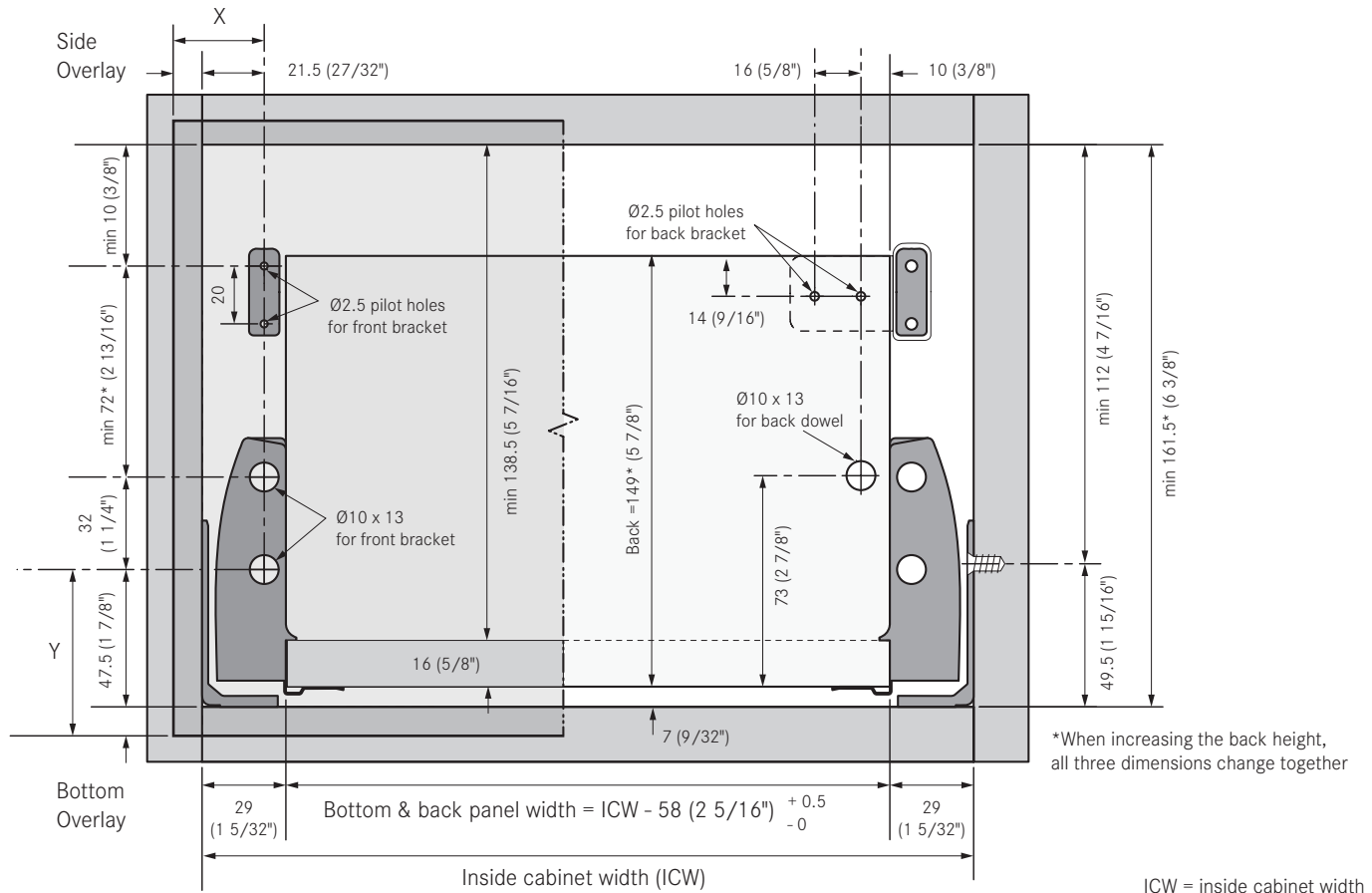

Nova Pro, Interior Drawer

P920 Series - 90mm (3 1/2") side height drawer system

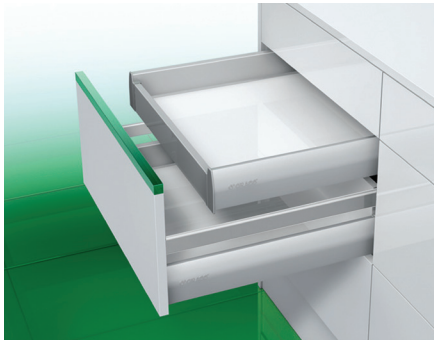

- Adding an aluminum front panel and coordinated brackets converts a Standard Drawer into an Interior Roll Out Drawer.
- Available load capacities: 88lb (40kg) and 154 lb (70kg) dynamic
- Soft-close liquid damping system
- Tool-free drawer front removal and installation
- Metallic finish

Cabinet Member Set and Drawer Member Set

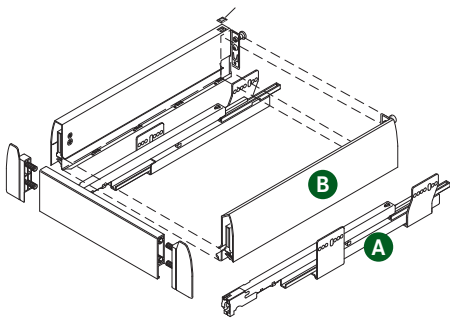

Description	Length	40kg (88 lb) capacity	70kg (154 lb) capacity	PU
A Nova Pro Cabinet Member Set	270 (11")	F101108261507	-	10
Nova Pro Cabinet Member Set	350 (14")	F101108267507	-	10
Nova Pro Cabinet Member Set	400 (16")	F101108270507	-	10
Nova Pro Cabinet Member Set	450 (18")	F101108273507	F101108285507	10
Nova Pro Cabinet Member Set	500 (20")	F101108276507	F101108288507	10
Nova Pro Cabinet Member Set	550 (22")	F101108279507	F101108291507	10

Description	Slide Length	Item No. Metallic	PU
B Nova Pro P920/270 Drawer Member Set	270 (11")	F100065000607	10
Nova Pro P920/350 Drawer Member Set	350 (14")	F100065006607	10
Nova Pro P920/400 Drawer Member Set	400 (16")	F100065009607	10
Nova Pro P920/450 Drawer Member Set	450 (18")	F100065012607	10
Nova Pro P920/500 Drawer Member Set	500 (20")	F100065015607	10
Nova Pro P920/550 Drawer Member Set	550 (22")	F100065018607	10

Cover Cap and Front Panel

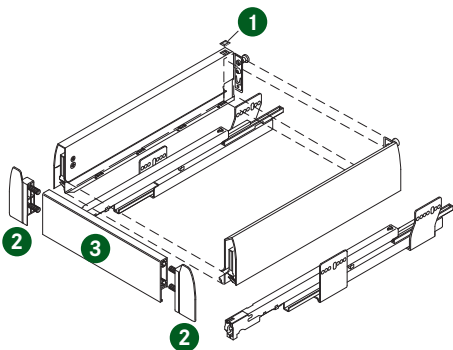

Description	Panel Length	Item No.	PU
1 U-cover cap		F102025821117	50
2 Panel holder set, Anthracite		F102066500204	5
3 610 Front panel - cut to size	610 (24")	F102068813204	5
1200 Front panel - cut to size	1200 (47 1/4")	F102051147204	5

Note: Select front panel by overall width

PU - Packaging unit

Drawer Back and Bottom Measurements

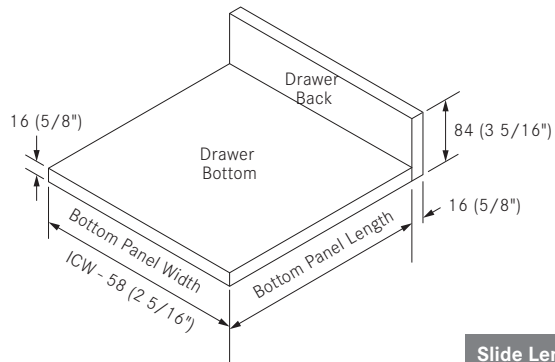

Inset front panel width = ICW - 85 (3 3/8")

If drawer member spacers are used, deduct their thickness from the inside cabinet width

Minimum Cabinet Depth

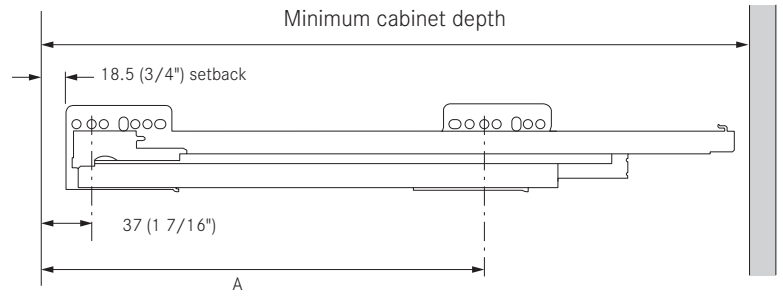

Attach with 13mm (1/2") long Euro screws or #7 X 5/8" wood screw.

Use 4 screws per side on 70kg (154 lb) slides.

Slide Length	Bottom Length	D	Minimum Cabinet Depth
270 (11")	251 (9 7/8")	197 (7 3/4")	284 (11 3/16")
350 (14")	331 (13 1/16")	261 (10 9/32")	364 (14 5/16")
400 (16")	381 (15")	261 (10 9/32")	414 (16 5/16")
450 (18")	431 (16 15/16")	325 (12 13/16")	464 (18 1/4")
500 (20")	481 (18 15/16")	325 (12 13/16")	514 (20 1/4")
550 (22")	531 (20 7/8")	325 (12 13/16")	564 (22 3/16")

Drawer Installation Dimensions

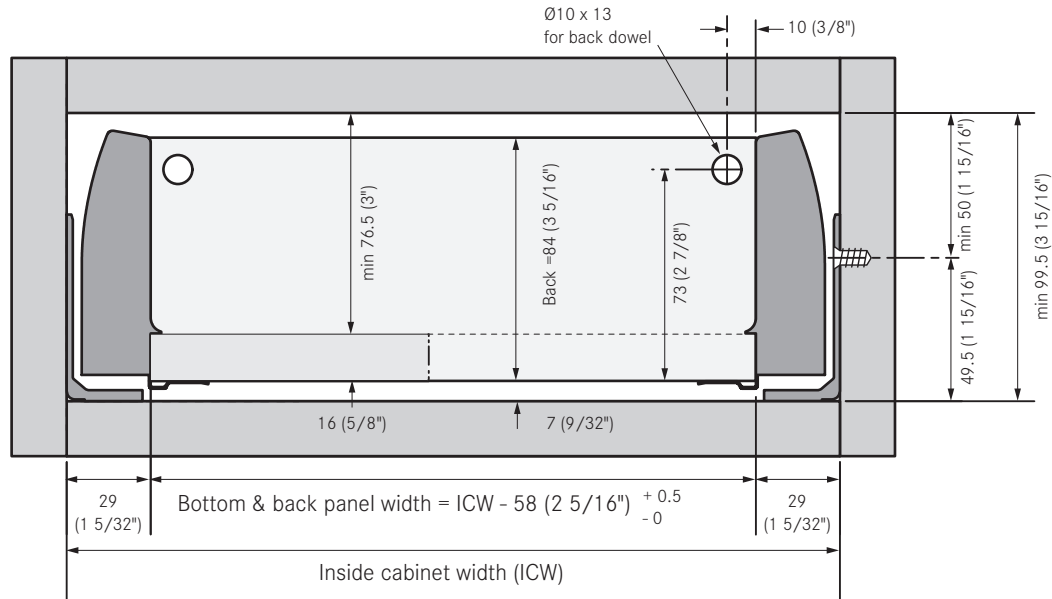

ICW = inside cabinet width

Nova Pro, Interior Drawer with Railings

P920 Series - 90mm (3 1/2") side height drawer system

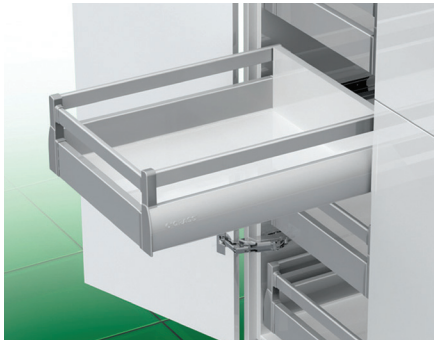

- Adding an aluminum front panel and coordinated brackets with a railing set converts a Standard Drawer into an Interior Roll Out Drawer with increased height.
- Available load capacities: 88lb (40kg) and 154 lb (70kg) dynamic
- Soft-close liquid damping system
- Tool-free drawer front removal and installation
- Metallic finish

Cabinet Member Set and Drawer Member Set

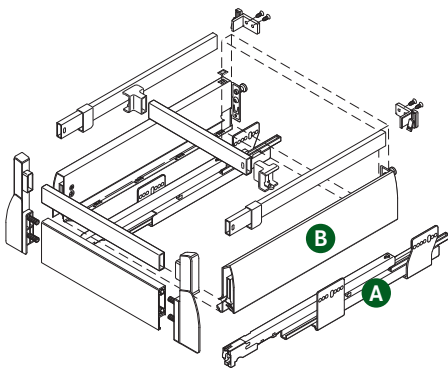

Description	Length	40kg (88 lb) capacity	70kg (154 lb) capacity	PU
A Nova Pro Cabinet Member Set	400 (16")	F101108270 507	-	10
Nova Pro Cabinet Member Set	450 (18")	F101108273 507	F101108285 507	10
Nova Pro Cabinet Member Set	500 (20")	F101108276 507	F101108288 507	10
Nova Pro Cabinet Member Set	550 (22")	F101108279 507	F101108291 507	10

Description	Slide Length	Item No. Metallic	PU
B Nova Pro P920/400 Drawer Member Set	400 (16")	F100065009 607	10
Nova Pro P920/450 Drawer Member Set	450 (18")	F100065012 607	10
Nova Pro P920/500 Drawer Member Set	500 (20")	F100065015 607	10
Nova Pro P920/550 Drawer Member Set	550 (22")	F100065018 607	10

Brackets, Cover Cap, and Railings

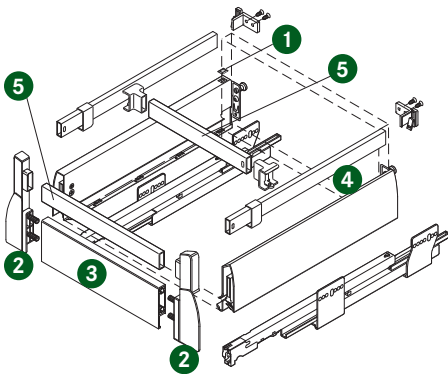

Description	Rail Length	Item No.	PU
1 U-cover cap		F102025821 117	50
2 Panel holder set, Anthracite		F102066500 204	5
3 610 Front panel - cut to size	610 (24")	F102068813 204	5
1200 Front panel - cut to size	1200 (47")	F102051147 204	5
4 Side Railing set with tilt adjustment 400	400 (16")	F102045860 507	10
Side Railing set with tilt adjustment 450	450 (18")	F102045861 507	10
Side Railing set with tilt adjustment 500	500 (20")	F102045862 507	10
Side Railing set with tilt adjustment 550	550 (22")	F102045863 507	10
5 Divider Railing set - cut to size	1200 (47 1/4")	F102051661 507	5

Note: Select front panel by overall width

PU - Packaging unit

Drawer Back and Bottom Measurements

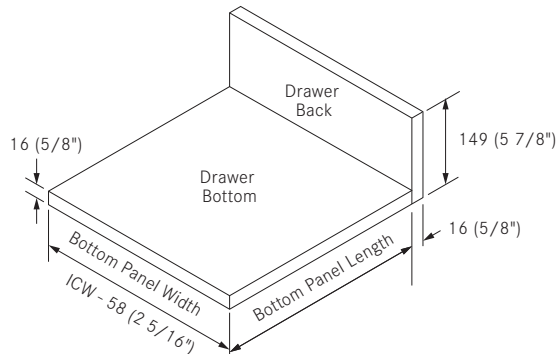

Inset front panel width = ICW - 85 (3 3/8")

Rail width = ICW - 55 (2 3/16")

Divider width = ICW - 55 (2 3/16")

If drawer member spacers are used, deduct their thickness from the inside cabinet width

Minimum Cabinet Depth

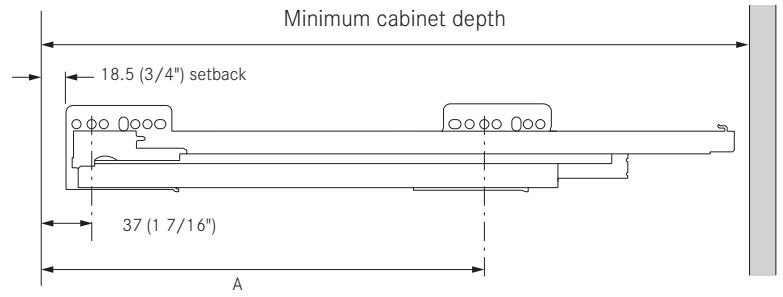

Attach with 13mm (1/2") long Euro screws or #7 X 5/8" wood screw.

Use 4 screws per side on 70kg (154 lb) slides.

Slide Length	Bottom Panel Length	A	Minimum Cabinet Depth
400 (16")	381 (15")	261 (10 9/32")	414 (16 5/16")
450 (18")	431 (16 15/16")	325 (12 13/16")	464 (18 1/4")
500 (20")	481 (18 15/16")	325 (12 13/16")	514 (20 1/4")
550 (22")	531 (20 7/8")	325 (12 13/16")	564 (22 3/16")

Drawer Installation Dimensions

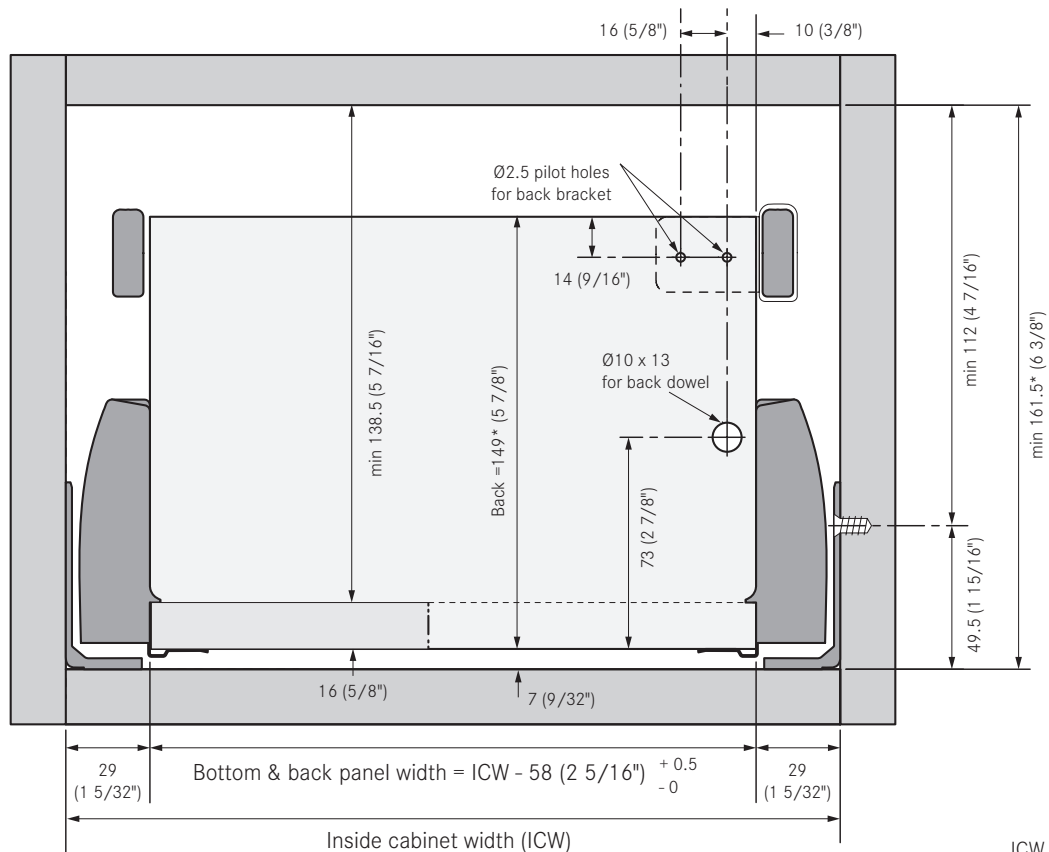

ICW = inside cabinet width

Nova Pro, Deep Drawer

P930 Series - 122mm (4 3/4") side height drawer system

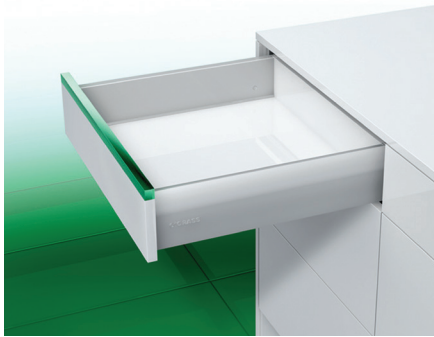

- The Deep Drawer is 32mm (1 1/4") taller than the Standard Drawer adding more storage capacity.
- Full extension for maximum access to drawer contents
- Available load capacities: 88lb (40kg) and 154 lb (70kg) dynamic
- Soft-close liquid damping system
- Tool-free drawer front removal and installation
- Cam height adjustment and tool-free side adjustment of drawer front
- Tilt adjustment for drawer front integrated in drawer side
- Metallic finish

Cabinet Member Set and Drawer Member Set

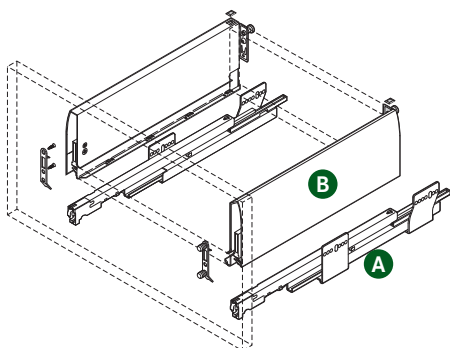

Description	Length	40kg (88 lb) capacity	70kg (154 lb) capacity	PU
A Nova Pro Cabinet Member Set	400 (16")	F101108270 507	-	10
Nova Pro Cabinet Member Set	450 (18")	F101108273 507	F101108285 507	10
Nova Pro Cabinet Member Set	500 (20")	F101108276 507	F101108288 507	10
Nova Pro Cabinet Member Set	550 (22")	F101108279 507	F101108291 507	10

Description	Slide Length	Item No. Metallic	PU
B Nova Pro P930/400 Drawer Member Set	400 (16")	F100065156 607	10
Nova Pro P930/450 Drawer Member Set	450 (18")	F100065159 607	10
Nova Pro P320/500 Drawer Member Set	500 (20")	F100065162 607	10
Nova Pro P320/550 Drawer Member Set	550 (22")	F100065165 607	10

Brackets and Cover Cap

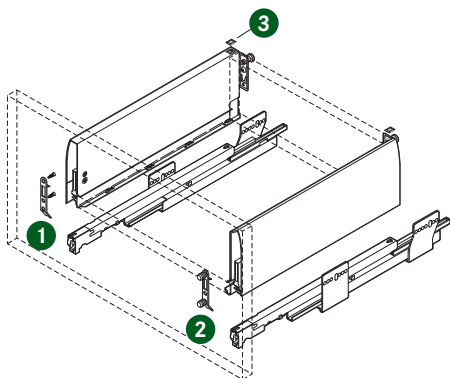

Description	Item No.	PU
1 Screw-on Bracket	F102021855 547	100
2 Dowelled Bracket	F102021854 123	100
3 U-cover cap	F10202582 1117	50

Note: Two brackets are required per drawer

Drawer Back and Bottom Measurements **Minimum Cabinet Depth**

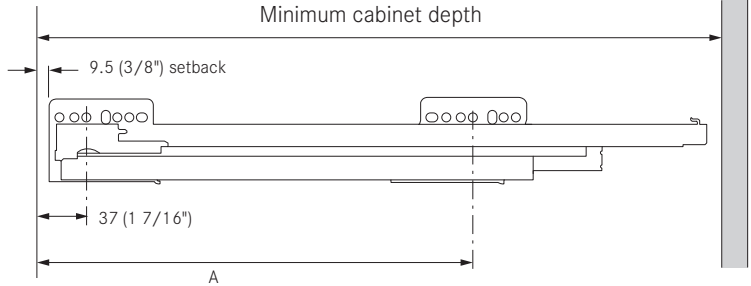
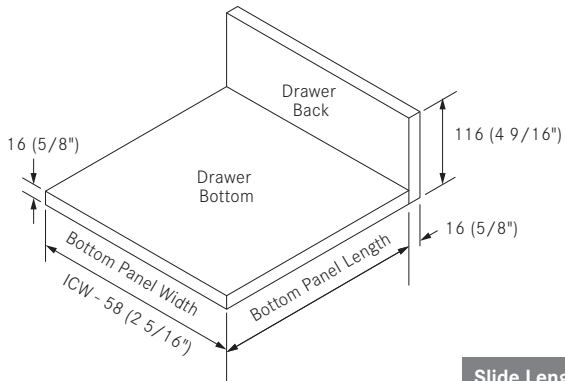

Attach with 13mm (1/2") long Euro screws or #7 X 5/8" wood screw.
Use 4 screws per side on 70kg (154 lb) slides.

Slide Length	Bottom Panel Length	A	Minimum Cabinet Depth
400 (16")	381 (15")	261 (10 9/32")	405 (15 15/16")
450 (18")	431 (16 15/16")	325 (12 13/16")	455 (17 15/16")
500 (20")	481 (18 15/16")	325 (12 13/16")	505 (19 7/8")
550 (22")	531 (20 7/8")	325 (12 13/16")	555 (21 7/8")

Drawer Installation Dimensions

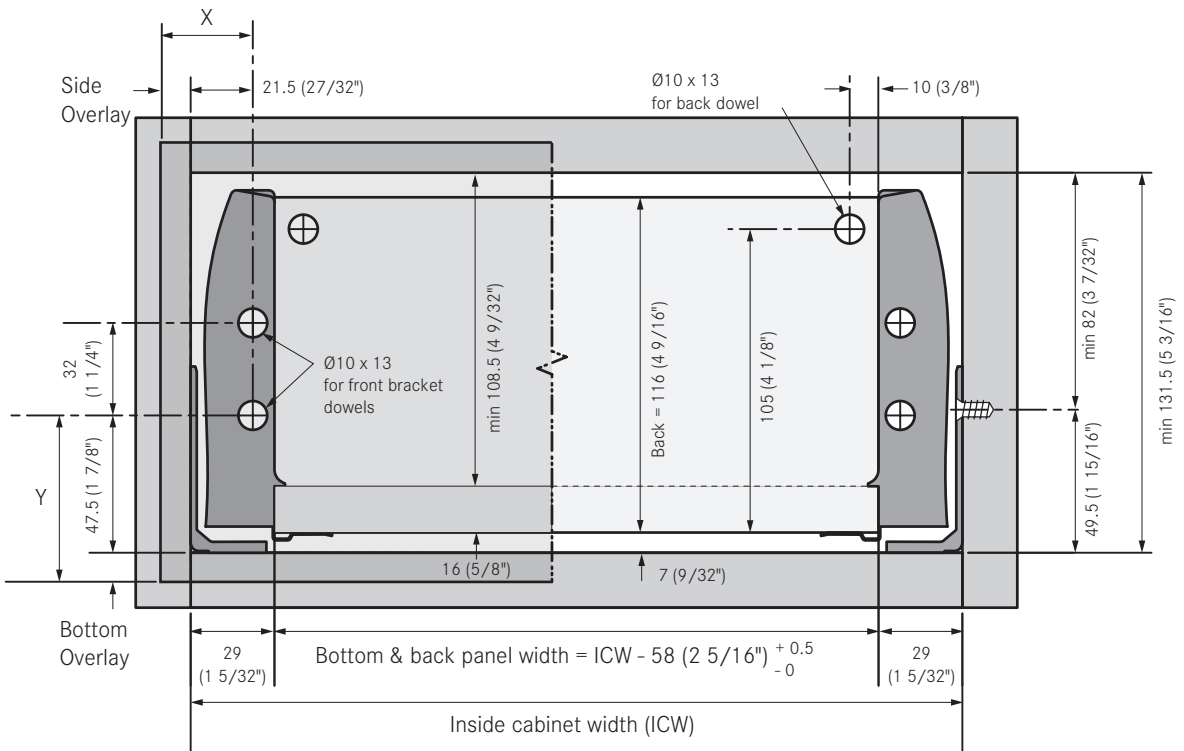

ICW = inside cabinet width

Nova Pro, Deep Drawer with Railing

P930 Series - 122mm (4 3/4") side height drawer system

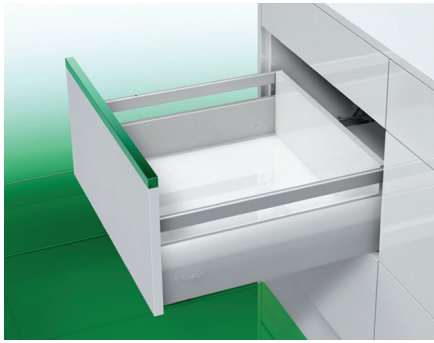

- Adding a railing set to the Deep Drawer provides more storage area and enables organization with Nova Pro divider railing set
- Full extension for maximum access to drawer contents
- Available load capacities: 88lb (40kg) and 154 lb (70kg) dynamic
- Soft-close liquid damping system
- Tool-free drawer front removal and installation
- Cam height adjustment and tool-free side adjustment of drawer front
- Railings provide drawer front tilt adjustment
- Metallic finish

Cabinet Member Set and Drawer Member Set

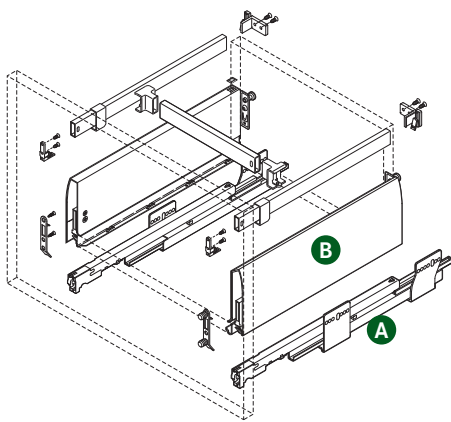

Description	Length	40kg (88 lb) capacity	70kg (154 lb) capacity	PU
A Nova Pro Cabinet Member Set	400 (16")	F101108270 507	-	10
Nova Pro Cabinet Member Set	450 (18")	F101108273 507	F101108285 507	10
Nova Pro Cabinet Member Set	500 (20")	F101108276 507	F101108288 507	10
Nova Pro Cabinet Member Set	550 (22")	F101108279 507	F101108291 507	10

Description	Slide Length	Item No. Metallic	PU
B Nova Pro P930/400 Drawer Member Set	400 (16")	F100065156 607	10
Nova Pro P930/450 Drawer Member Set	450 (18")	F100065159 607	10
Nova Pro P930/500 Drawer Member Set	500 (20")	F100065162 607	10
Nova Pro P930/550 Drawer Member Set	550 (22")	F100065165 607	10

Brackets, Cover Cap, and Railings

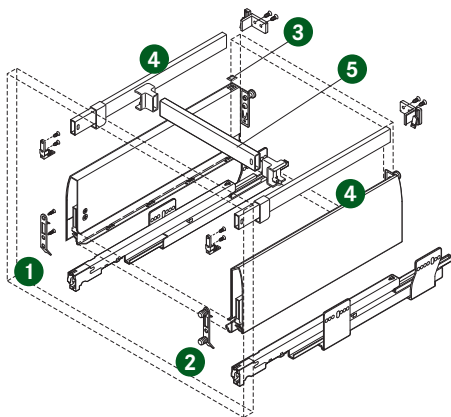

Description	Rail Length	Item No.	PU
1 Screw-on Bracket		F102021855 547	100
2 Dowelled Bracket		F102021854 123	100
3 U-cover cap		F10202582 1117	50
4 Side Railing set with tilt adjustment 400	400 (16")	F102045860 507	10
Side Railing set with tilt adjustment 450	450 (18")	F10204586 1507	10
Side Railing set with tilt adjustment 500	500 (20")	F102045862 507	10
Side Railing set with tilt adjustment 550	550 (22")	F102045863 507	10
5 Divider Railing set - cut to size	1200 (47 1/4")	F10205166 1507	5

Note: Two brackets are required per drawer

PU - Packaging unit

Drawer Back and Bottom Measurements **Minimum Cabinet Depth**

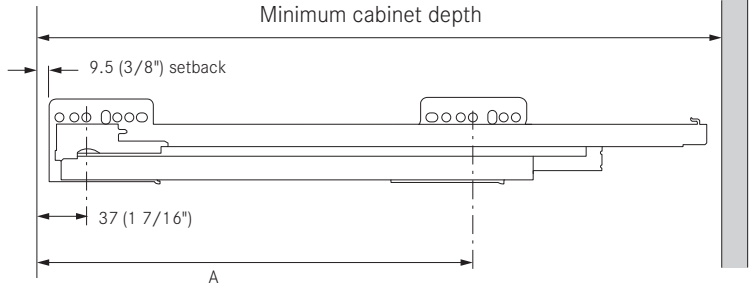
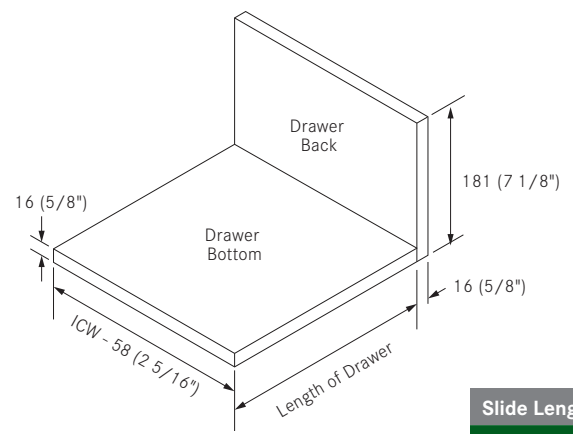

Attach with 13mm (1/2") long Euro screws or #7 X 5/8" wood screw.
Use 4 screws per side on 70kg (154 lb) slides.

Slide Length	Bottom Panel Length	A	Minimum Cabinet Depth
400 (16")	381 (15")	261 (10 9/32")	405 (15 15/16")
450 (18")	431 (16 15/16")	325 (12 13/16")	455 (17 15/16")
500 (20")	481 (18 15/16")	325 (12 13/16")	505 (19 7/8")
550 (22")	531 (20 7/8")	325 (12 13/16")	555 (21 7/8")

Drawer Installation Dimensions

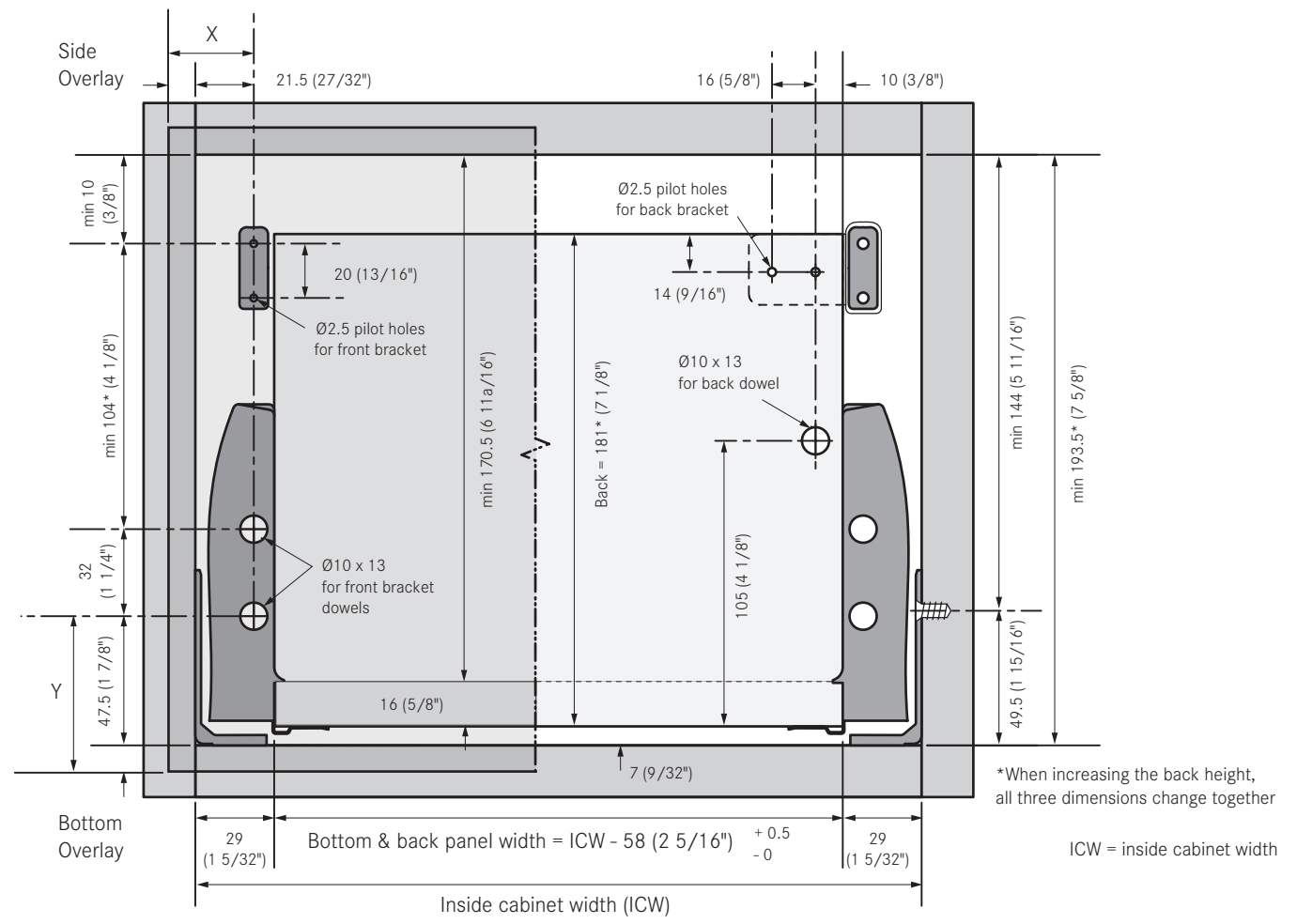

3595 Aluminum File Rail

For Nova Pro

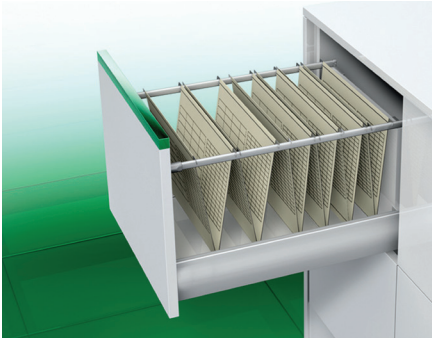

- Keep hanging files organized
- Install file railing system independent from drawer system
- Front tilt adjustment
- Oval aluminum anodized

3595 Railing System

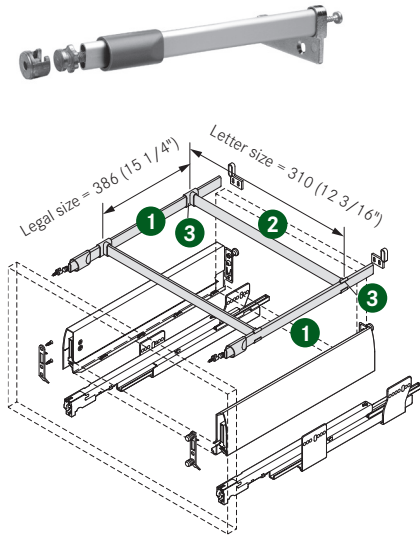

Description	Slide Length	Item No.	PU
1 File Railing Set	500 (20")	F084074850511	20
File Railing Set	550 (22")	F084074851511	20
2 Divider Rail	1200 (47 1/4")	F084074854223	20
3 Divider Clips		F084074857133	20

File Railing set consists of:

- 2 Side gallery rails
- 2 Front fixing parts
- 2 Back fixing parts
- 2 Cover caps

Front Tilt Adjustment

Installation Instructions

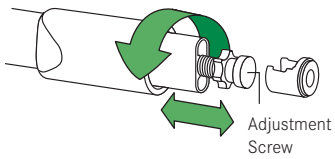

Assembly:

1. Prepare back, bottom and front.
2. Mark position of side rail.
3. Screw-on back and front fixing parts.
4. Attach side rail to back bracket, then insert into front bracket.
5. Adjust if necessary and slide cover cap forward.

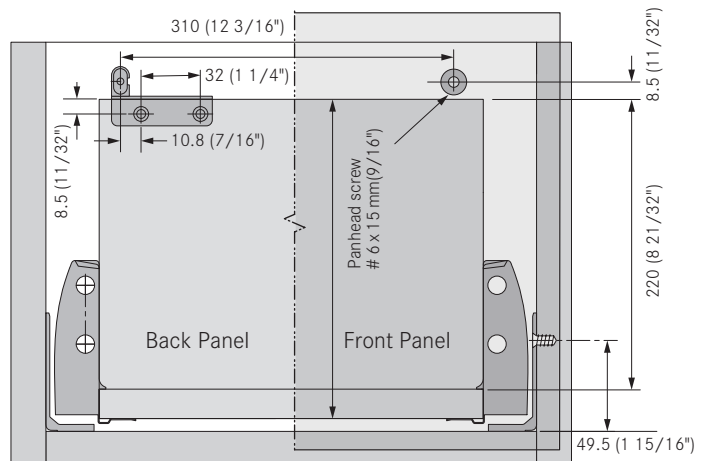

PU - Packaging unit

For Nova Pro

Cabinet Member Spacer

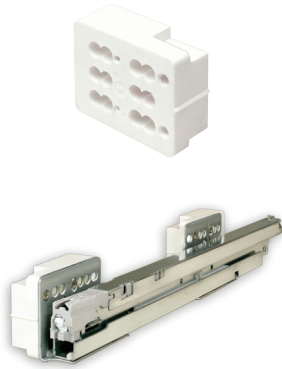

Used to space slides away from the cabinet sides on interior drawer applications.

- 25 mm (1") thick, white molded plastic
- Universal, non-handed
- Can be mounted with Euro or wood screws
- Use (2) per side

Description	Item No.	PU
P601-001 Spacer	F102062616211	20

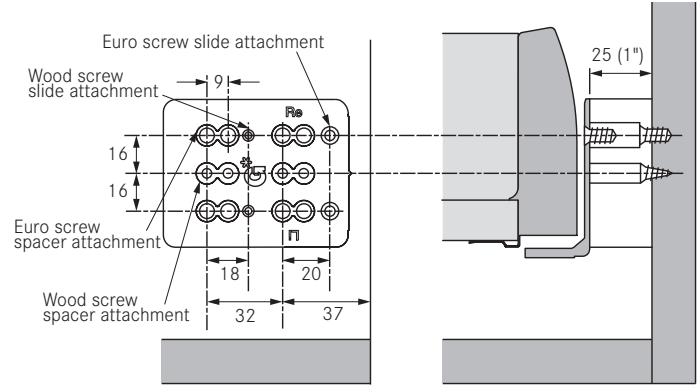

Interior Drawer Bracket Kit

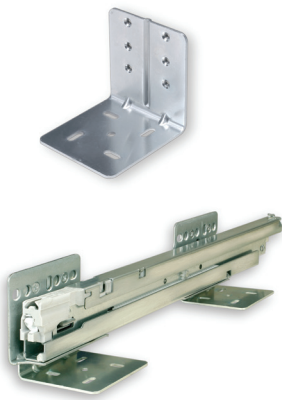

Used to mount slides to a cabinet bottom or shelf for interior roll out trays.

Description	Item No.	PU
Interior drawer bracket	00443-40	25

Kit consists of:

- 4 non-handed zinc plated steel brackets
- 8 M4 screws to attach slides to brackets
- 8 #8 x 5/8" truss head screws to mount brackets to cabinet

Top

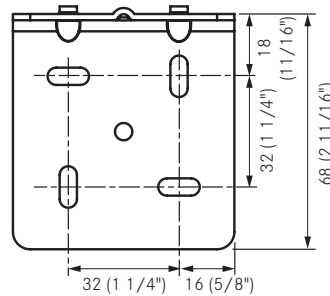

Side

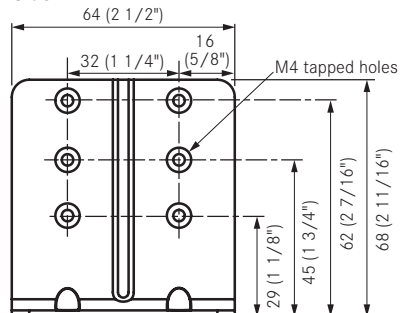

Front

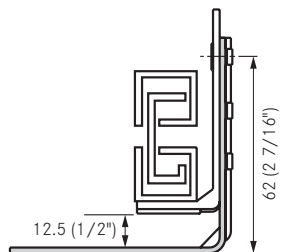

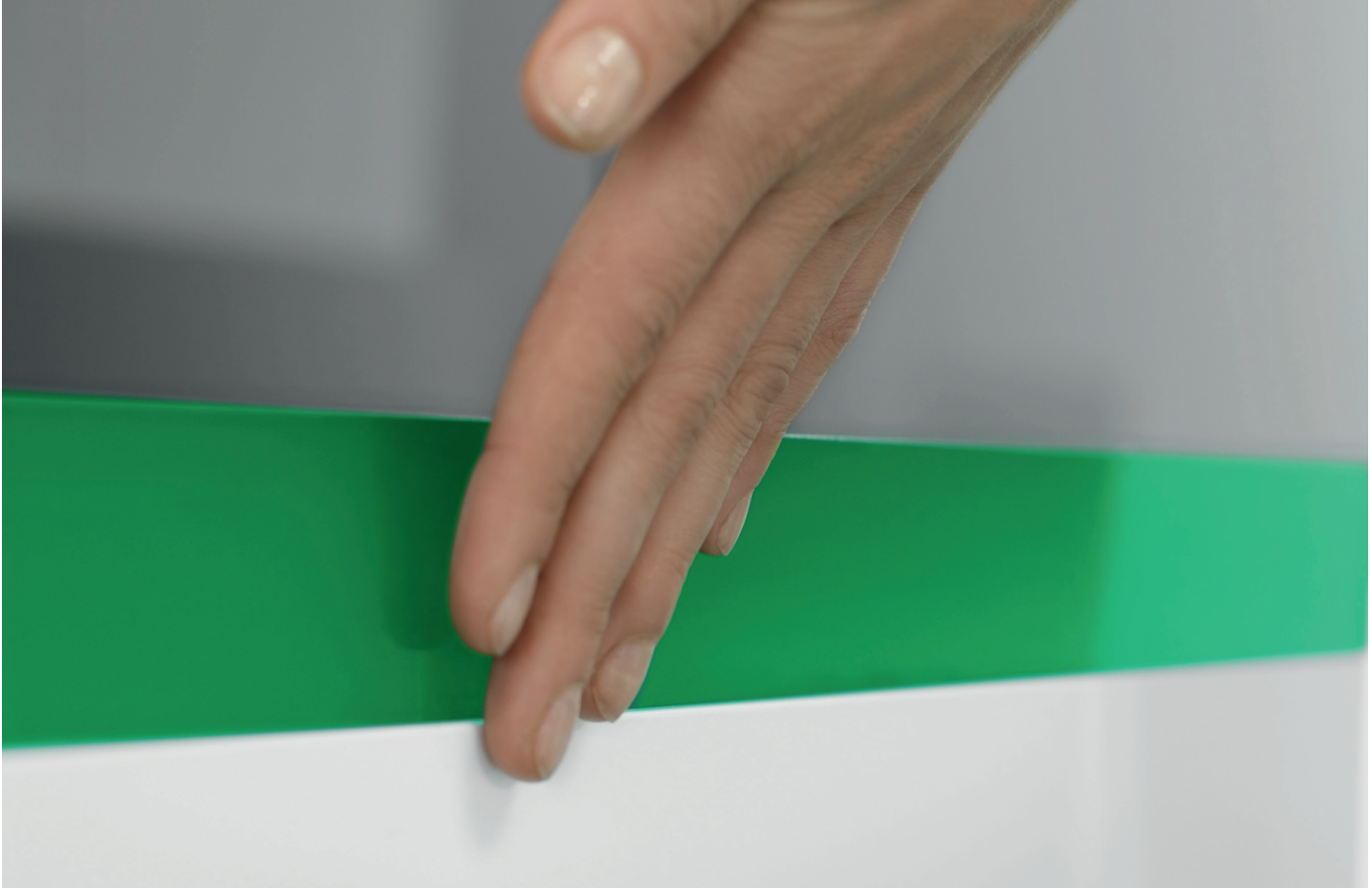

Sensomatic combines handle-free opening with the ever popular Soft-closing action

Just tap anywhere on the drawer front and the drawer opens automatically.

The Sensomatic is an electro-mechanical opening system that works with the Nova Pro Drawer system. A simple installation process creates a superior drawer system.



Versatile. Efficient. Exciting.
 Sensomatic combines handle-free
 opening with the ever popular
 Soft-closing action.
 Fully automatic, electrically powered.

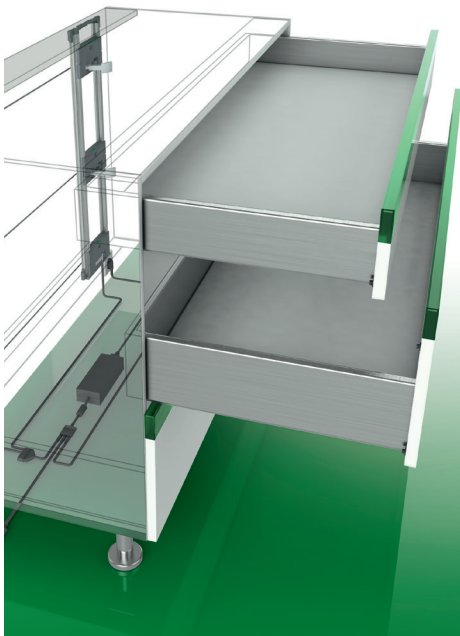

SENSOMATIC OPENING SYSTEM

Sensomatic, an electro-mechanical opening system that can be activated by a light touch anywhere on the surface of the drawer front. At the touch, the drawers glide open in one smooth motion.

A simple installation process creates a superior drawer system. The action is steady, precise and ingenious. The perfect movement for today's functional requirements.

Sensomatic is extremely efficient in regard to power consumption and occupied space. The Sensomatic needs only one drive unit for cabinet widths up to 48" (1219mm) regardless of the weight. Accessories such as wire baskets, trash can receptacles, or roll out trays can be fitted with the Sensomatic system without modification. It has never been easier to open a drawer and - never easier to close a drawer.

Sensomatic together with Soft-close offers all the advantages of handle free opening with the elegance and functionality of a soft-closing action. These functions together guarantee your operating convenience at the highest level.

Sensomatic for Nova Pro

Standard cabinet with horizontal wooden stretcher

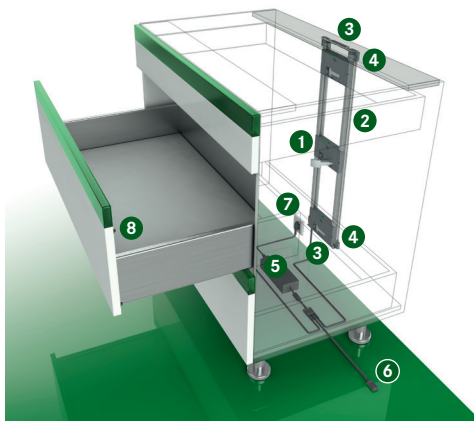

- Electro-mechanical opening system
- Sensomatic works with any Nova Pro drawer design
- Activated by a light touch anywhere on the drawer front
- One drive unit for cabinets widths up to 48" (1219mm)
- Soft-closing action pulls the drawer closed
- Ideal for accessories such as wire baskets, waste bins, or roll-out trays
- Full extension for maximum access to drawer contents

1 Opening Unit

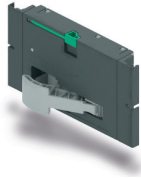

	Item No.	PU
For Nova Pro	F121100268607	10

PU - 10 Pieces, individually packaged

2 Frame Sides, Including Frame Side Cable

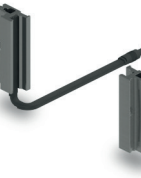

Length	Item No.	PU
750mm	F121100285207	10
1170mm	F121100286207	10

PU - 10 Pairs

3 Frame Connector

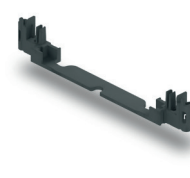

	Item No.	PU
Frame connector	F121100282211	20

4 Fixing Bracket

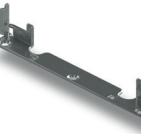

	Item No.	PU
Fixing bracket	F121100270211	1

5 Power Supply Unit



	Item No.	PU
Power supply unit	F121100269607	10

PU = 10 pieces, individually packaged

One power supply operates up to 30 opening units

6 Connection Cable with 2-way-adapter



Length	Item No.	PU
1000mm	F121100289207	10
1600mm	F121100290207	10
2000mm	F121100291207	10

7 Power Cord, 1.8 m (6')



Type of plug	Item No.	PU
Power cord (USA, CA)	F120069760207	10

8 Spring-loaded Front Bumper



Ø 5mm	Item No.	PU
Front gap 2.2mm	F121100294223	100
Front gap 3mm	F121100295223	100
Front gap 4mm	F121100296223	100

PU - Packaging unit

Mounting Dimensions

Fixing brackets positioned at top and bottom

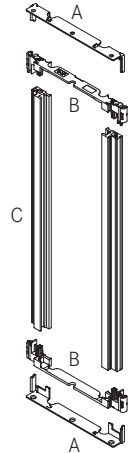
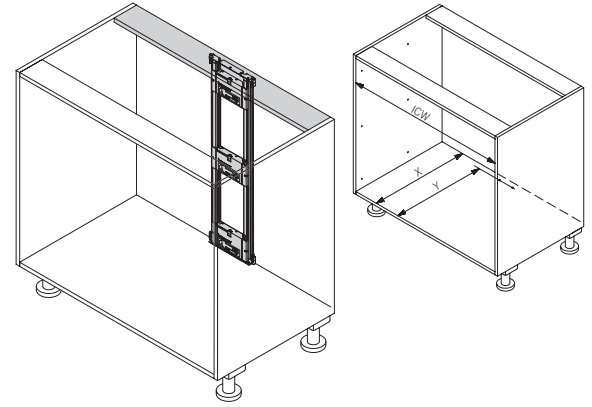
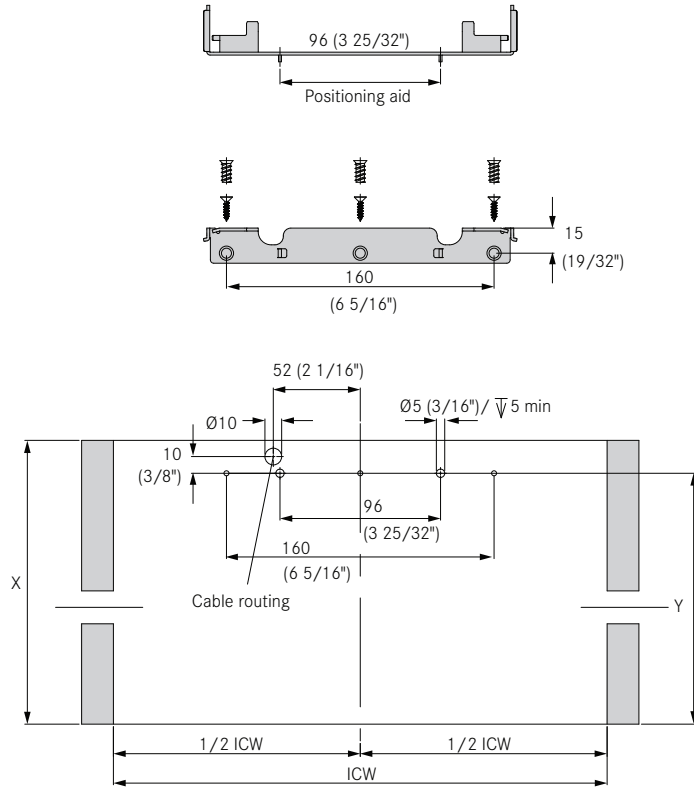

Mounting dimensions Nova Pro	X	Y	Min ICW
Wood back panel	NL + 20 (25/32")	NL + 5 (3/16")	262 (10 5/16")

Legend

Position of Opening Unit for Nova Pro

Position of Front Bumper

- A = fixing bracket used at top and bottom
- B = frame connector
- C = frame sides
- ICW = inside cabinet width
- NL = nominal length of cabinet slide
- X = min installation depth
- Y = depth of hole pattern

- FSL = frame side length
- ICH = inside cabinet height

- FH = front height
- FO = front overlay

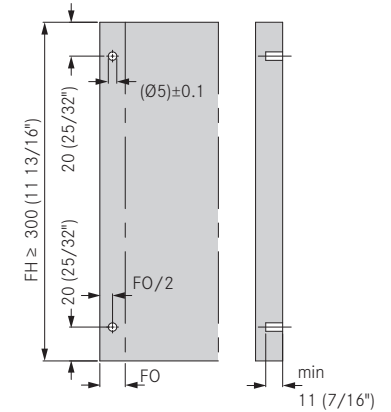
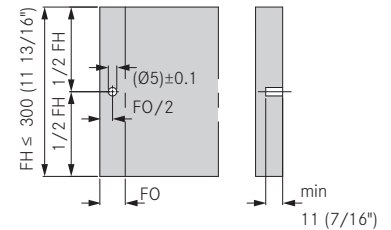
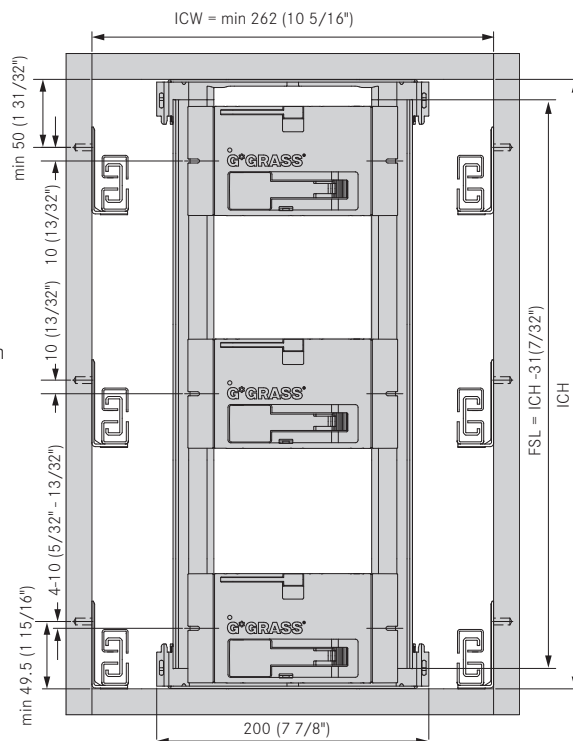

When mounting the heavy-duty slide (154 lb), it is necessary to insert 4 front bumpers into the drawer front.

Do not drive in or glue front bumpers

Sensomatic for Nova Pro

Standard cabinet with vertical wooden stretcher

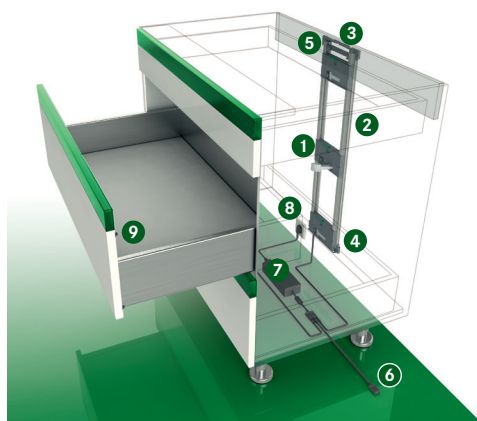

- Electro-mechanical opening system
- Sensomatic works with any Nova Pro drawer design
- Activated by a light touch anywhere on the drawer front
- One drive unit for cabinets widths up to 48" (1219mm)
- Full extension for maximum access to drawer contents
- Soft-closing action pulls the drawer closed
- Ideal for accessories such as wire baskets, waste bins, or roll-out trays

1 Opening Unit

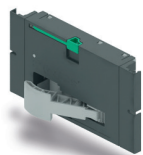

	Item No.	PU
For Nova Pro	F121100268607	10

PU - 10 Pieces, individually packaged

2 Frame Sides, including Frame Side Cable



Length	Item No.	PU
750mm	F121100285207	10
1170mm	F121100286207	10

PU - 10 Pairs

3 Frame Connector

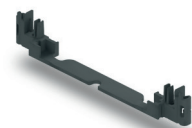

	Item No.	PU
Frame connector	F121100282211	20

4 Fixing Bracket



	Item No.	PU
Fixing bracket	F121100270211	1

5 Rear-mount Fixing Brackets



	Item No.	PU
Flush mount	F121100275207	10

6 Connection Cable with 2-way-adaptor



Length	Item No.	PU
1000mm	F121100289207	10
1600mm	F121100290207	10
2000mm	F121100291207	10

7 Power Supply Unit



	Item No.	PU
Power supply unit	F121100269607	10

PU = 10 pieces, individually packaged
One power supply operates up to 30 opening units

8 Power Cord, 1.8 m (6')



Type of plug	Item No.	PU
Power cord (USA, CA)	F120069760207	10

9 Spring-loaded Front Bumper



Ø 5mm	Item No.	PU
Front gap 2.2mm	F121100294223	100
Front gap 3mm	F121100295223	100
Front gap 4mm	F121100296223	100

PU - Packaging unit

Mounting Dimensions

Fixing bracket positioned at bottom

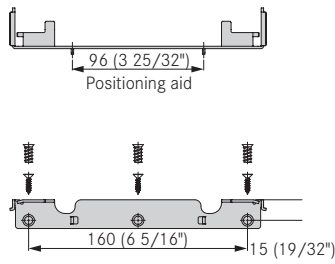

Rear-mount fixing bracket (flush mount)

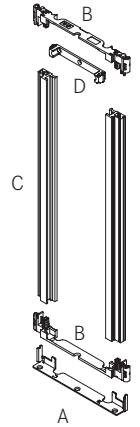
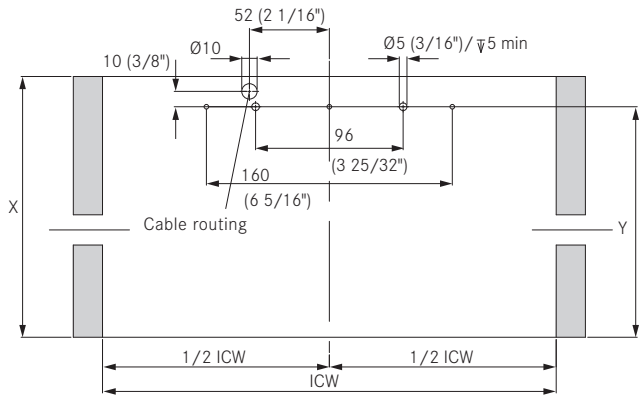
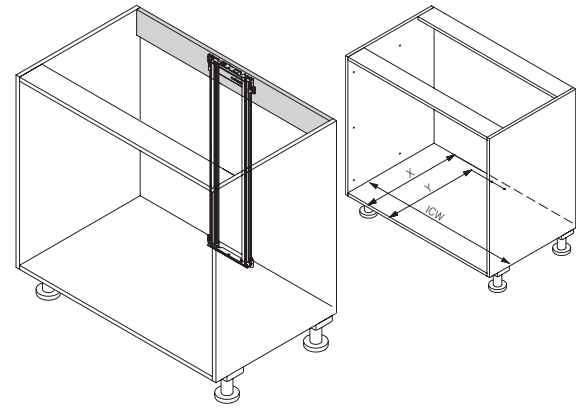
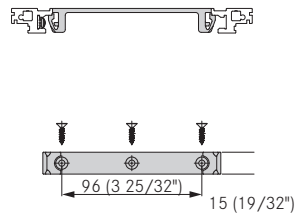

Mounting dimensions Nova Pro	X	Y	Min ICW
Wood back panel	NL + 20 (25/32")	NL + 5 (3/16")	262 (10 5/16")

Legend

Position of Opening Unit for Nova Pro

Position of Front Bumper

- A = fixing bracket used at top and bottom
- B = frame connector
- C = frame sides
- D = Rear mount fixing bracket, flush
- ICW = inside cabinet width
- NL = nominal length of cabinet slide
- X = min installation depth
- Y = depth of hole pattern

FSL = frame side length
 ICH = inside cabinet height

FH = front height
 FO = front overlay

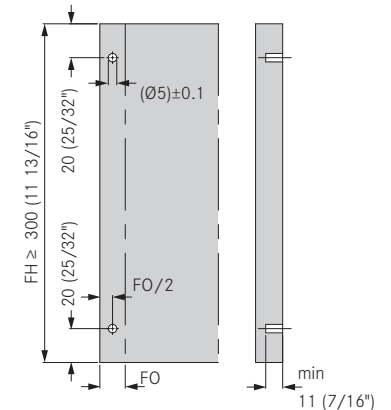
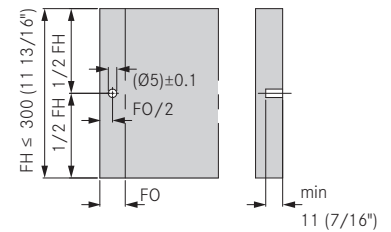
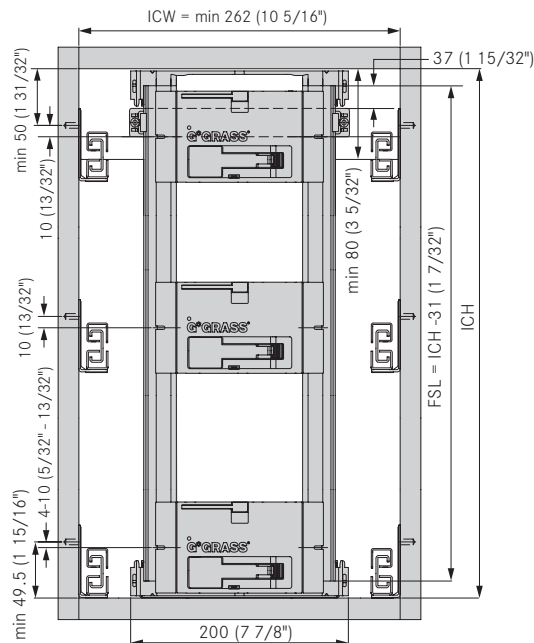

When mounting the heavy-duty slide (154 lb), it is necessary to insert 4 front bumpers into the drawer front.

Do not drive in or glue front bumpers

Sensomatic for Nova Pro

Single drawer with top mounting

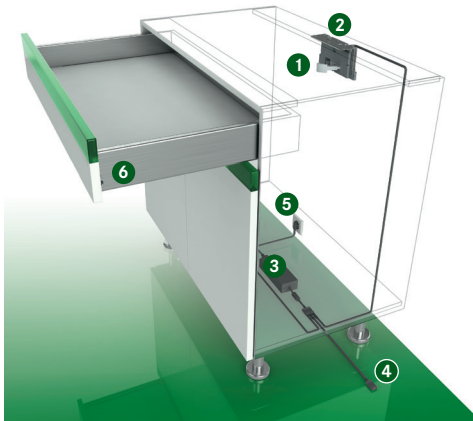

- Electro-mechanical opening system
- Sensomatic works with any Nova Pro drawer design
- Activated by a light touch anywhere on the drawer front
- One drive unit for cabinets widths up to 48" (1219mm)
- Full-extension for maximum access to drawer contents
- Soft-closing action pulls the drawer closed
- Ideal for accessories such as wire baskets, waste bins, or roll-out trays

1 Opening Unit

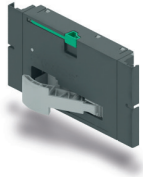

	Item No.	PU
For Nova Pro	F121100268607	10

PU - 10 Pieces, individually packaged

2 Frame for Top Assembly

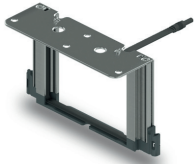

	Item No.	PU
Height 120mm (4 23/32")	F121100272207	10

3 Power Supply Unit



	Item No.	PU
Power supply unit	F121100269607	10

PU = 10 pieces, individually packaged. One power supply operates up to 30 opening units

4 Connection Cable with 2-way-adapter



Length	Item No.	PU
600mm	F121100288207	10
1000mm	F121100289207	10
1600mm	F121100290207	10
2000mm	F121100291207	10

5 Power Cord, 1.8 m (6')



Type of plug	Item No.	PU
Power cord (USA, CA)	F120069760207	10

6 Spring-loaded Front Bumper



Ø 5mm	Item No.	PU
Front gap 2.2mm	F121100294223	100
Front gap 3mm	F121100295223	100
Front gap 4mm	F121100296223	100

PU - Packaging unit

Mounting Dimensions

Back wall cabling

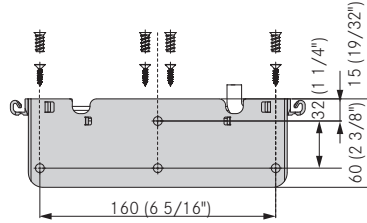
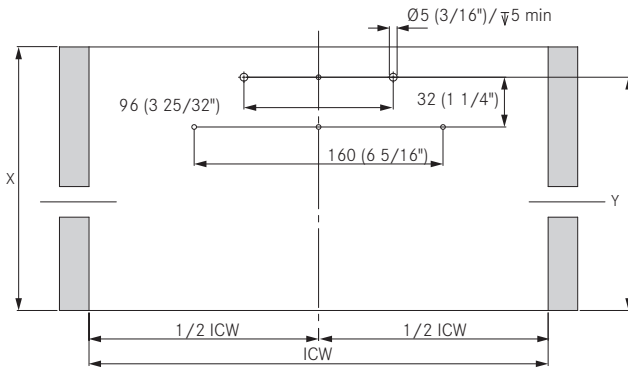
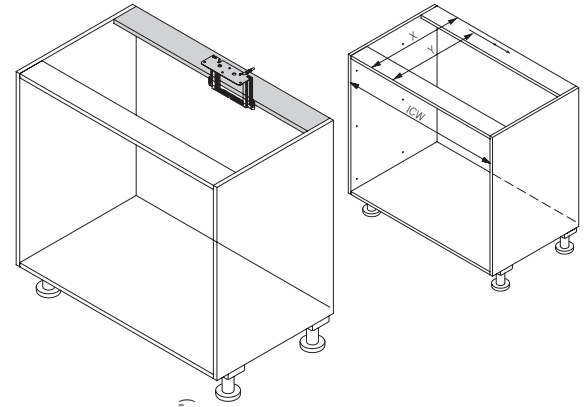
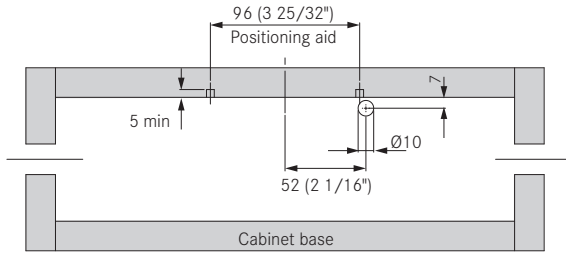

Mounting dimensions Nova Pro	X	Y	Min ICW
Wood back panel	NL + 20 (25/32")	NL + 5 (3/16")	262 (10 5/16")

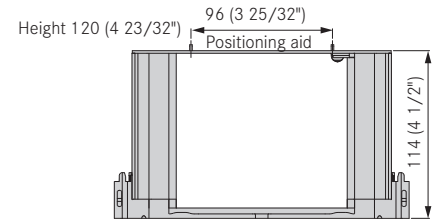

Legend

Position of Opening Unit for Nova Pro

Position of Front Bumper

Height 120 (4 23/32")

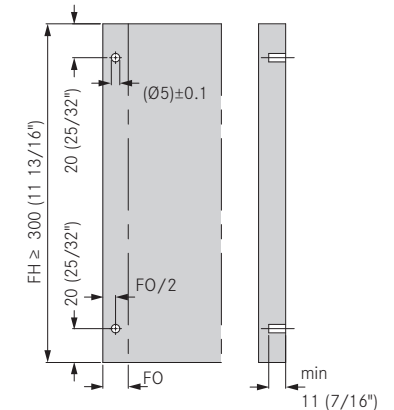
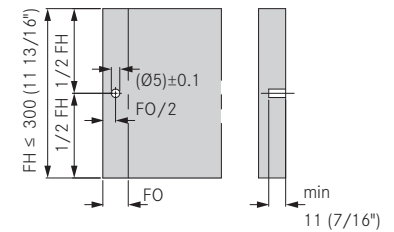
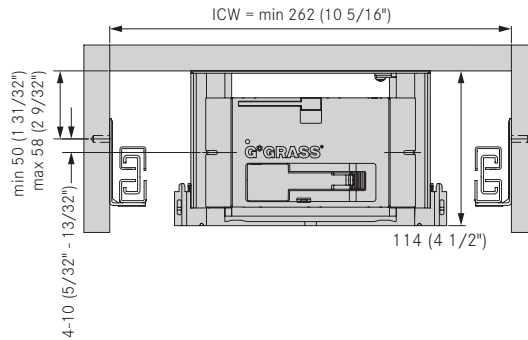

ICW = inside cabinet width
 NL = nominal length of cabinet slide
 X = min installation depth
 Y = depth of hole pattern

FH = front height
 FO = front overlay

When mounting the heavy-duty slide (154 lb), it is necessary to insert 4 front bumpers into the drawer front.

Do not drive in or glue front bumpers

Sensomatic for Nova Pro

Waste bin cabinet with bottom panel frame mounting

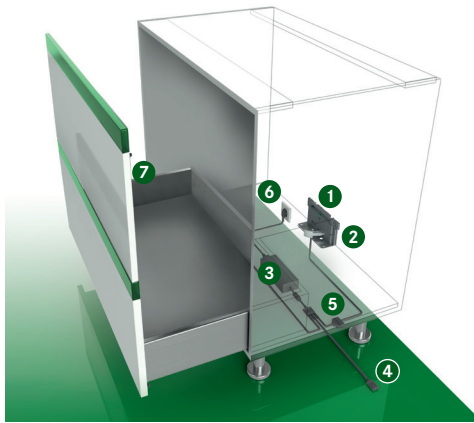

- Electro-mechanical opening system
- Sensomatic works with any Nova Pro drawer design
- Activated by a light touch anywhere on the drawer front
- One drive unit for cabinets widths up to 48" (1219mm)
- Full-extension for maximum access to drawer contents
- Soft-closing action pulls the drawer closed
- Ideal for accessories such as wire baskets, waste bins, or roll-out trays

1 Opening Unit

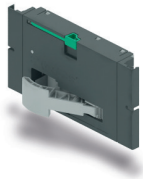

	Item No.	PU
For Nova Pro	F121100268 607	10
PU - 10 Pieces, individually packaged		

2 Base Frame



	Item No.	PU
for Nova Pro	F121100271 207	10

3 Power Supply Unit



	Item No.	PU
Power supply unit	F121100269 607	10
PU = 10 pieces, individually packaged One power supply operates up to 30 opening units		

4 Connection Cable with 2-way-adapter



Length	Item No.	PU
1000mm	F121100289 207	10
1600mm	F121100290 207	10
2000mm	F121100291 207	10

5 4-way-adapter



Type of plug	Item No.	PU
4-way-adapter	F121100293 207	10

6 Power Cord, 1.8 m (6')



Type of plug	Item No.	PU
Power cord (USA, CA)	F120069760 207	10

7 Spring-loaded Front Bumper



Ø 5mm	Item No.	PU
Front gap 2.2mm	F121100294 223	100
Front gap 3mm	F121100295 223	100
Front gap 4mm	F121100296 223	100

Sensomatic Kit



Set includes:

Opening unit: 1 Power cord: 1
 Base frame: 1 Front bumpers: 4
 Power supply unit : 1 (F121100294223)

	Item No.	PU
For Nova Pro	F121100697 201	1

PU = 1 set

PU - Packaging unit

Mounting Dimensions

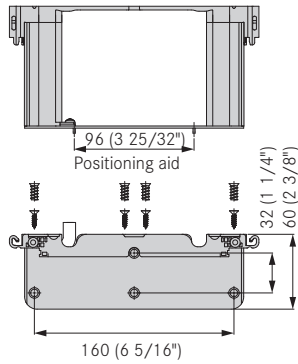

Base mounting

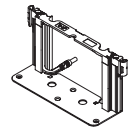
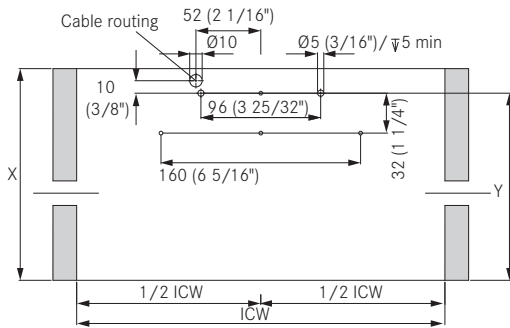
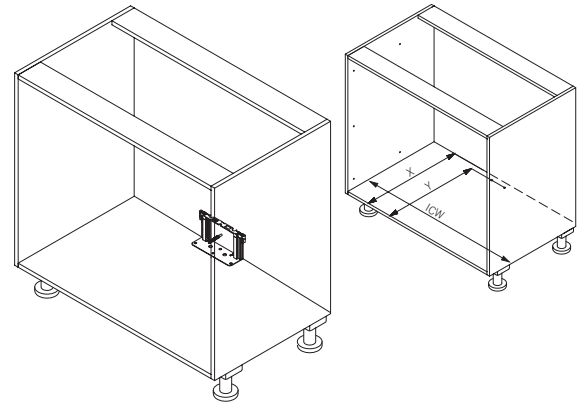

Base frame

Mounting dimensions Nova Pro	X	Y	Min ICW
Wood back panel	NL + 20 (25/32")	NL + 5 (3/16")	262 (10 5/16")

Legend

Position of Opening Unit for Nova Pro

Position of Front Bumper

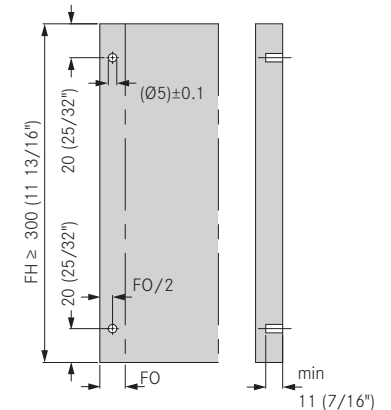
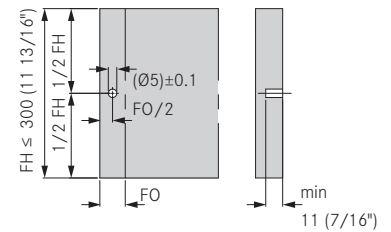
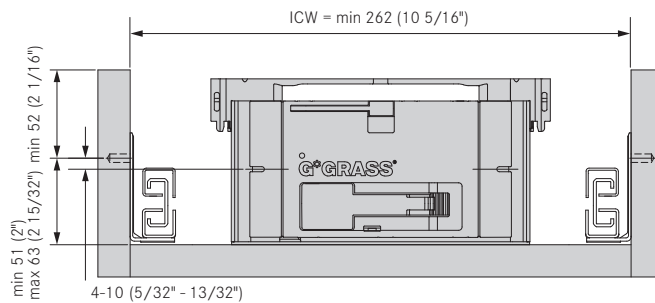

ICW = inside cabinet width
 NL = nominal length of cabinet slide
 X = min installation depth
 Y = depth of hole pattern

FH = front height
 FO = front overlay

When mounting the heavy-duty slide (154 lb), it is necessary to insert 4 front bumpers into the drawer front.

Do not drive in or glue front bumpers



GRASS America Inc.
1202 NC Highway 66 South
Kernersville, NC 27284

Phone: 1-800-334-3512
Fax: 1-800-525-8406

Website: www.grassusa.com
E-mail: info@grassusa.com

GRASS Canada Inc.
10 Newgale Gate, Unit 7
Toronto, ON M1X 1C5

Phone: 1-800-461-4975
Fax: 1-416-335-5907

Internet: www.grasscanada.com
E-Mail: info@grasscanada.com



www.grassusa.com