

ELEVATION

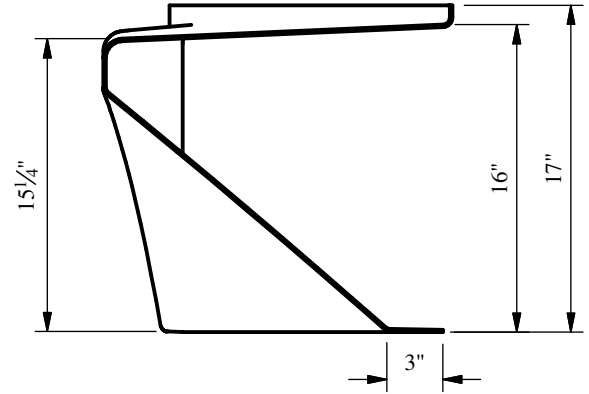

SECTION C-C

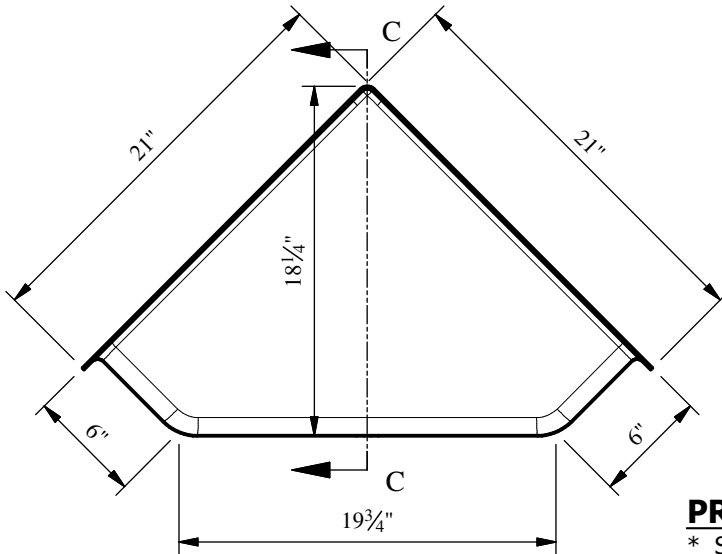

PLAN

PRODUCT SPECIFICATION:

- * Special installation instruction for this unit must be followed carefully.
- * Product complies with NAHB, HUD UM-73A, & ANSI-Z124.1.2.
- * Product has a Class B fire rating as determined by ASTM E-84 test method.
- * Reinforced & slip resistant seat.
- * Molded seat.
- * Integral 1" [25mm] nailing flange.
- * All dimensions =/± 1/2" [12.8mm]
- * Clarion Bathware reserves the right to change design and/or dimensions.
- * Dimensions are the same for RE, MP, and all other versions of this model.

SPCS21

Molded Shower Seat for Shower Pans

Clarion
BATHWARE
44 Amsler Ave.
Shipperville, PA 16254

Phone: (814) 226-5374
Toll Free: (800) 576-9228
Fax: (814) 226-0730
www.clarionbathware.com

Signatures For Approval:

Customer: _____
Arch./Engr: _____

Date:

DWG. #
SPCS-21-CUT

Quote #: _____
Job Name: _____

By: NMH
Date: 4/26/2017

IMPOTANT NOTICE

Clarion bathware reserves the right to change the design and/or dimensions of its products at any time. This drawing may have been updated since this publication was issued. Before placing an order for any product, refer to our website at www.clarionbathware.com to obtain the most current drawings for any products that you wish to purchase. Compare the date of revision of the drawing that you have with the one on the drawing on our website. If you do not have internet access, please call your sales representative or Clarion Bathware's sales department at 1-800-576-9228.