

ENGINEERING SPECIFICATIONS: - Brass shower arm with polished nickel chrome plated surface. Flange is stamped 300 series stainless steel.

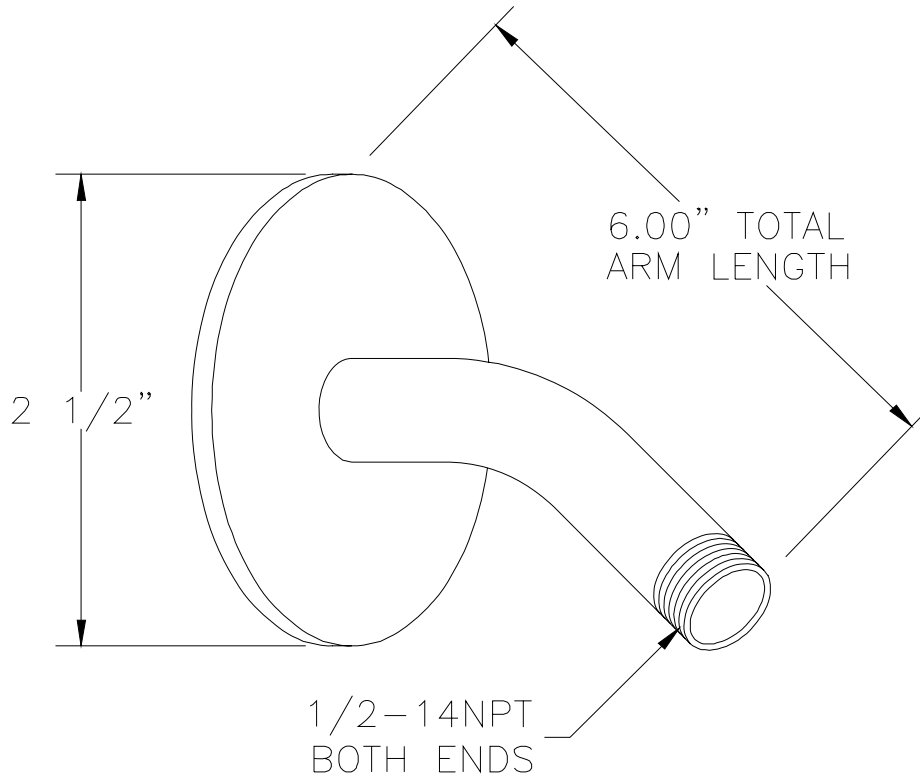

Note: All dimensions are for reference only. Do not use for pre-plumbing

OPTIONS (Check/specify appropriate options)

STANDARDS

Description

Standard arm with chrome plated die-cast zinc wall flange

Tested to meet the following standards:
Tub spout meets CSA B125 M89



TEMP-GARD STANDARD SHOWER ARM AND WALL FLANGE

Clarion
BATHWARE
44 Amsler Ave.
Shipperville, PA 16254

Phone: (814) 226-5374
Toll Free: (800) 576-9228
Fax: (814) 226-0730
www.clarionbathware.com

Mold Fabrication will not begin until approved drawing is received.
Standard mold production is (_____ weeks) unless quoted otherwise.

Signatures For Approval: _____ Date: _____
Customer: _____
Clarion Engineer: _____
Clarion SVP of Sales: _____

DWG. #
Fixed Shower
Head Arm/Flange
Dwg. By: NMH
Date: 5/7/2020