

SHOWER DOME INSTALLATION

Clarion
EVERYDAY LUXURY

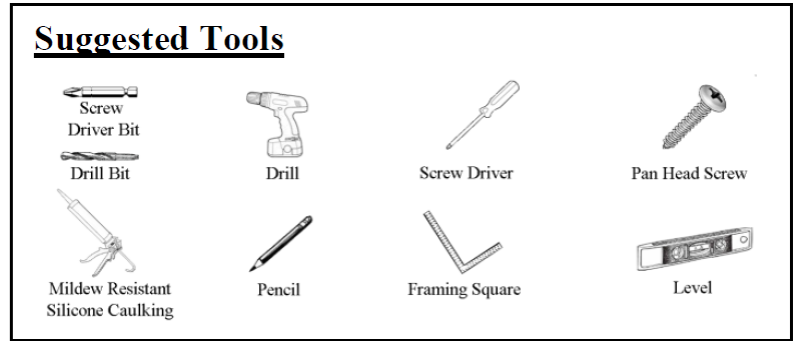

1. Please consult all local and state building codes, and read the entire installation instructions prior to beginning the installation of this unit to ensure that the installation is performed correctly.
2. Construct a framed pocket that is square and plumb in accordance with rough-in dimensions. When determining the height of the pocket, take into consideration the height of the dome. (See Figure 1)

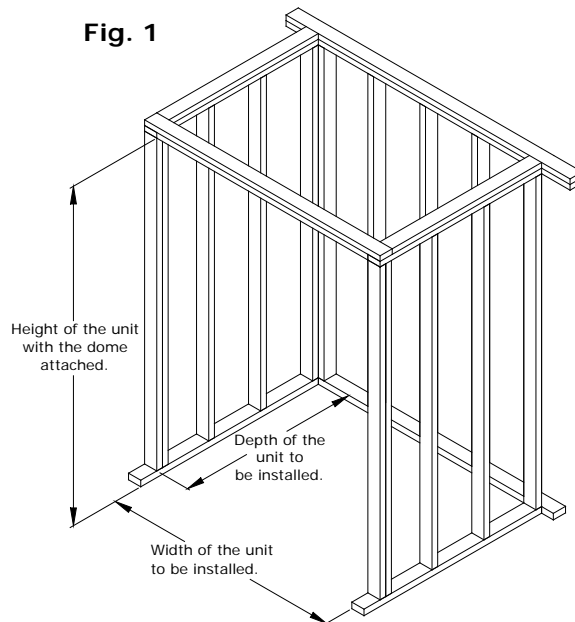

At this point of the installation, the method used depends upon whether or not there will be access to the back and sides of the unit after it is installed to allow installation of the dome. If there will be access to the back and sides of the unit after installing the unit, METHOD 1 should be used to install a unit with a cap. If there will not be access to the unit after it is installed, METHOD 2 should be used to install the unit.

METHOD 1

3. Set the dome aside and install the unit according to its instructions.
4. After the unit is installed, place the dome on the unit. From behind the studding, attach the dome using stove bolts. **A bead of silicone caulking (not latex caulking) may be placed on the bolt locations and inside the seam between the dome and the unit.**
5. Attach the side flanges and the top flange of the dome to the studding using screws. (See Figure 2) Secure the flanges every 6" or as necessary to keep the flanges flush to the studding.

Fig. 2

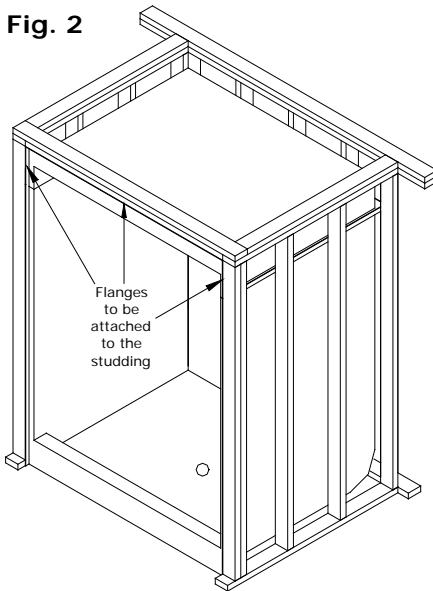

METHOD 2

3. Attach the dome to the unit using stove bolts. **A bead of silicone caulking (not latex caulking) may be placed on the bolt locations and inside the seam between the dome and the unit.**
4. Install the unit per its installation instructions, omitting the step of screwing the horizontal flanges to the studding.
5. Attach the side flanges and the top flange of the dome to the studding using screws. (*See Figure 2*) Secure the flanges every 6" or as necessary to keep the flanges flush to the studding.
6. You can finish off your new tub with a variety of materials. (tile, drywall, caulking, plaster of paris, wood or plastic trim).
7. Clean your new tub with a liquid detergent and warm water.
Do not use any abrasive cleaners such as scouring powder, or liquid abrasive cleaners.

IF YOU HAVE ANY QUESTIONS REGARDING INSTALLATION OF YOUR CLARION BATHWARE PRODUCT, PLEASE CALL OUR CUSTOMER SERVICE DEPARTMENT AT 1 (800) 576-9228 OR BY E-MAIL AT CUSTOMERSERVICE@CLARIONBATHWARE.COM

CLARION BATHWARE PRODUCTS ARE CERTIFIED TO MEET CSA B45.5/IAPMO Z124 STANDARD. FOR DETAILS, PLEASE REFER TO ICC-ES PMG CERTIFICATION PROGRAM.

Clarion
EVERYDAY LUXURY

44 Amsler Avenue
Shippenville, PA 16254
(814) 226-5374 or (800) 576-9228
Fax: (814) 226-0730 www.clarionbathware.com



AcrylX™ with the Strength of ArmorCore™ Lifetime Warranty



This warranty applies to all Clarion Bathware AcrylX™ with Armorcore™ base reinforcement produced after 1-23-2017.

Clarion Bathware warrants to the original purchaser and consumer that its products will be free from defects in material or workmanship when properly installed pursuant to Clarion Bathware installation instructions for the following warranty periods:

Warranty Details: On your new Clarion unit, you will find a medallion sticker. On this sticker it says “Clarion” and has a Serial Number that starts with “CL”, PLEASE do not remove this sticker. This number will be needed if you would require a warranty claim to be processed.

Lifetime Warranty

- (1) AcrylX™, Residential* Use
- (2) CenturyStone™, Residential* Use

Thirty (30) Year Warranty

- (1) AcrylX™, Commercial* Use
- (2) CenturyStone™, Commercial* Use

Upon inspection by an authorized representative, Clarion Bathware will repair or exchange at its sole discretion, any unit found to be defective in material or workmanship. The exchange of a unit will only be considered when Clarion Bathware has eliminated all options to restore the unit to acceptable factory condition. Exchange of a unit is limited to supplying replacement product of comparable size and style, and does not include any cost of removal or installation.

EXCEPTIONS

This warranty shall be voided if the unit is moved from its place of initial installation or is not installed in accordance with the instructions supplied by the manufacturer of the unit. Clarion Bathware will not be held responsible for any damages resulting from improper installation.

Further, this warranty does not apply if the unit has been subjected to accident, abuse, misuse, damage caused by flood, fire, or other force of nature.

Any unauthorized repair or modification to the product would render the warranty null and void.

This warranty does not apply to any equipment or accessories not installed by Clarion Bathware and Clarion Bathware will not be held liable for any results of such acts.

Clarion Bathware is not responsible for any consequential or incidental mishaps, inconvenience, time loss, incidental expense, materials or labor related to the installation of hardware or the actual tub.

The owner agrees by use of the unit that the obligations of Clarion Bathware shall not extend to contingent or indirect damage or injury to the structure of its contents, that the obligations of Clarion Bathware are limited to those set forth herein, and that no other obligations, expressed or implied, are assumed by Clarion Bathware.

The product is not recommended for outside storage.

To obtain warranty service, the Customer must give prompt notice to Clarion Bathware of any claim.

Clarion Bathware is a division of American Bath Group Inc.

*Residential Use is considered any unit Installed in a permanent residence dwelling of Individual ownership, such as but not limited to single family home, multi-family home, or condominium. Commercial Use is considered transient lodging, such as but not limited to healthcare facility, dormitory, hotel, or apartment complex.