

## Residential Shower Base Seat SPCS21 Installation

**WARNING: FAILURE TO FOLLOW THESE INSTALLATION INSTRUCTIONS COULD VOID THIS PRODUCTS WARRANTY.** These instructions are meant to be used in conjunction with the installation instructions for the shower base to be installed. They will be used during the framing of the pocket for the base. Please read all steps (for both this seat and the shower base) before starting the installation.

### **Step 1 Provide additional studding** (Figure 1)

In addition to a properly framed pocket, studding needs to be provided for the (4) flanges of the seat in the locations shown. The vertical members shall be placed 20 $\frac{3}{4}$ " (Dim 'A') from the inside corner to the centerline of the stud. Horizontal studs will be placed 16 $\frac{3}{4}$ " (Dim 'B') above the rim of the properly leveled base to the centerline of the stud. Perform a 'dry-fit' of the seat to verify studding locations. Flanges should align with studding.

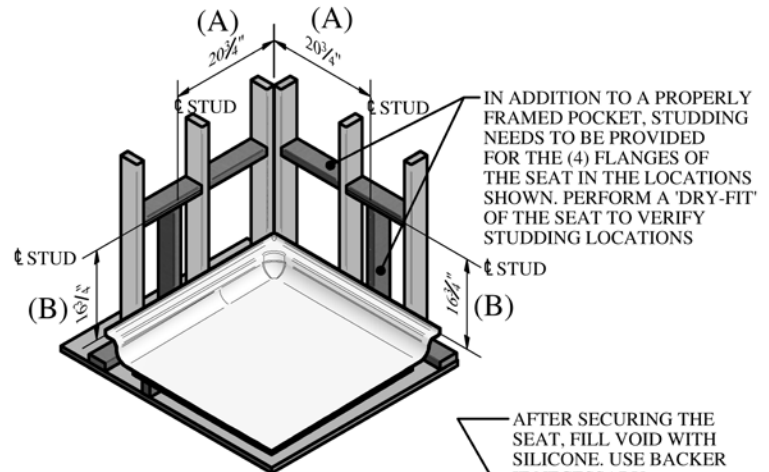

FIGURE 1

### **Step 2 Predrill seat to studding** (Figure 2)

After the shower base has been properly leveled and secured according to its instructions, dry-fit the seat once again. Verify alignment and mark & predrill (3) evenly spaced holes along each of the (4) flanges (2-vertical & 2-horizontal). Note: If using a self-tapping type screw, predrilling is not necessary.

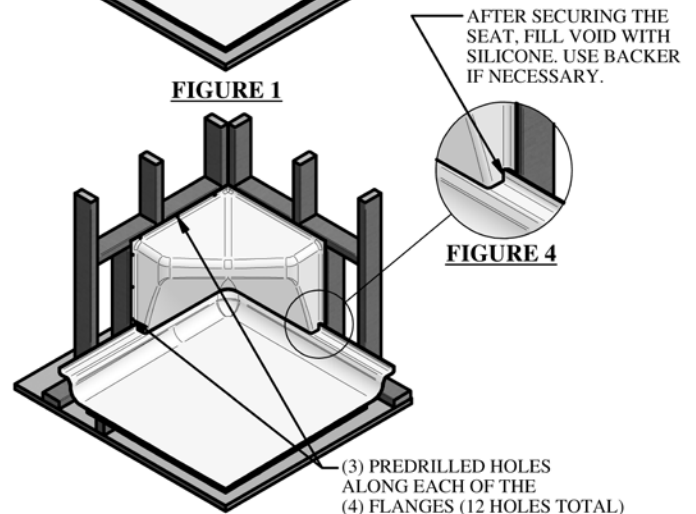

FIGURE 2

### **Step 3 Apply silicone** (Figure 3)

Clean up debris from drilling and apply a continuous bead of silicone adhesive where the seat will contact the base (Fig 3 'C'). Reposition seat back onto the base.

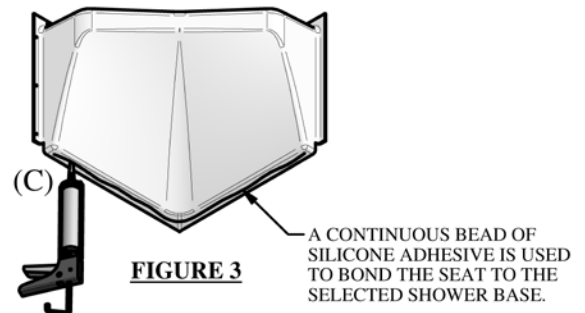

FIGURE 3

### **Step 4 Secure the seat**

Secure the seat to the studding using galvanized screws. Take care to not over tighten. Fill void (Figure 4) with silicone. Use backer if necessary. Clean up any excess adhesive according to the manufactures instructions.

Final installation can now be done.

**IF YOU HAVE ANY QUESTIONS REGARDING INSTALLATION OF YOUR CLARION BATHWARE PRODUCT, PLEASE CALL OUR CUSTOMER SERVICE DEPARTMENT AT 1 (800) 576-9228 OR BY E-MAIL AT [Customerservice@Clarionbathware.com](mailto:Customerservice@Clarionbathware.com)**

### **JOB SITE INSTALLATION OF OWNER SUPPLIED ACCESSORIES**

Job-site installation of third party supplied accessories is entirely at the risk and full responsibility of the owner. Any damage to Clarion Bathware units or the property during or after accessory installation, or any injuries due to improper installation remain the sole responsibility of said owner and cannot be attributed to Clarion Bathware, Inc.

CLARION BATHWARE PRODUCTS ARE CERTIFIED TO MEET CSA B45.5/IAPMO Z124 STANDARD. FOR DETAILS, PLEASE REFER TO ICC-ES PMG CERTIFICATION PROGRAM.



# AcryIX™ with the Strength of ArmorCore™ Lifetime Warranty



This warranty applies to all Clarion Bathware AcryIX™ with Armorcore™ base reinforcement produced after 1-23-2017.

Clarion Bathware warrants to the original purchaser and consumer that its products will be free from defects in material or workmanship when properly installed pursuant to Clarion Bathware installation instructions for the following warranty periods:

#### Lifetime Warranty

- (1) AcryIX™, Residential\* Use
- (2) CenturyStone™, Residential\* Use

#### Thirty (30) Year Warranty

- (1) AcryIX™, Commercial\* Use
- (2) CenturyStone™, Commercial\* Use

Upon inspection by an authorized representative, Clarion Bathware will repair or exchange at its sole discretion, any unit found to be defective in material or workmanship. The exchange of a unit will only be considered when Clarion Bathware has eliminated all options to restore the unit to acceptable factory condition. Exchange of a unit is limited to supplying replacement product of comparable size and style, and does not include any cost of removal or installation.

#### **EXCEPTIONS**

This warranty shall be voided if the unit is moved from its place of initial installation or is not installed in accordance with the instructions supplied by the manufacturer of the unit. Clarion Bathware will not be held responsible for any damages resulting from improper installation.

Further, this warranty does not apply if the unit has been subjected to accident, abuse, misuse, damage caused by flood, fire, or other force of nature.

Any unauthorized repair or modification to the product would render the warranty null and void.

This warranty does not apply to any equipment or accessories not installed by Clarion Bathware and Clarion Bathware will not be held liable for any results of such acts.

Clarion Bathware is not responsible for any consequential or incidental mishaps, inconvenience, time loss, incidental expense, materials or labor related to the installation of hardware or the actual tub.

The owner agrees by use of the unit that the obligations of Clarion Bathware shall not extend to contingent or indirect damage or injury to the structure of its contents, that the obligations of Clarion Bathware are limited to those set forth herein, and that no other obligations, expressed or implied, are assumed by Clarion Bathware.

The product is not recommended for outside storage.

To obtain warranty service, the Customer must give prompt notice to Clarion Bathware of any claim.

Clarion Bathware is a division of American Bath Group Inc.

\*Residential Use is considered any unit Installed in a permanent residence dwelling of Individual ownership, such as but not limited to single family home, multi-family home, or condominium. Commercial Use is considered transient lodging, such as but not limited to healthcare facility, dormitory, hotel, or apartment complex.