

Tools you might need for proper installation

- screws
- 4 foot level
- screw gun
- shims
- adhesive (to secure shims)

Thank you for purchasing Praxis Bathware. For best results, please read and follow all directions carefully.

STORAGE AND HANDLING OF ACRYLIC UNITS

Do not store units out of doors.- Keep out of sunlight and exposure to weather.

1. Most handling damage is the result of impact blows to the back side of the fiberglass reinforcement.
2. Stress cracks can develop when shipping boards are removed before unit is positioned for final installation in bathroom.
3. Placing objects inside of tub can cause scratches, abrasions or nicks to the acrylic surface.
4. Storing units outside right-side up can cause the sunlight to discolor the acrylic finish. Also, unit becomes unstable and is easily knocked over by wind or bumping.
5. The back side of a fiberglass unit isn't waterproof.

Unit must be stored so that water will drain off of unit and not accumulate in any one spot. Water can permeate the back laminates and soak the glassed in wood or cardboard supports causing bulges in the acrylic surface.

6. Never drag an acrylic unit on any surface. Always transport the unit by hand using (2) people or a two wheel dolly.
 7. Never let an acrylic unit drop from any height, not even an inch.
 8. Never clean the acrylic surface with metal tools of any kind, including razors.
- **Very Important for Modified Threshold Units:*
Modified threshold acrylic barrier free shower stalls - An acrylic shower stall with less than a 2" threshold has to be stored and installed with care. During storage this unit should not sit as it as received. It should be stored either upside down resting on the top of the unit or with a 2" x 4" block of some other type of material at each of the (4) points numbered (see Figure 1).

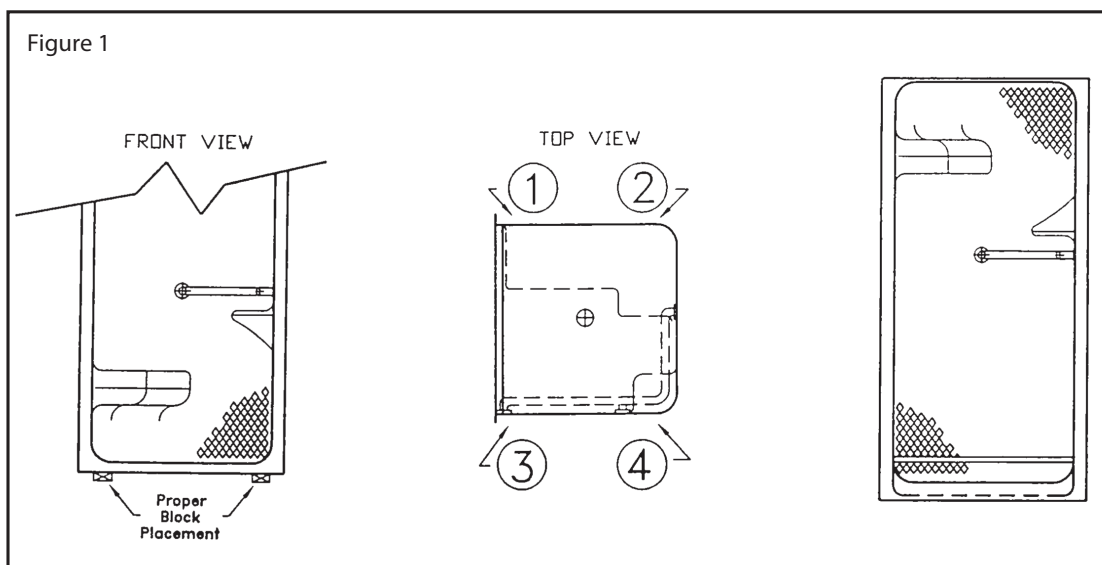

Units having altered threshold heights do not have wooden bottoms to reinforce the floors. By placing the unit on some type of block, the drain will not rest on the floor. This will allow the draft of the shower floor to be maintained without the weight of the shower unit pushing the drain upward. The block should only be placed at the outside corner edges of the unit and should not be placed under the middle of the threshold. This procedure should only be used during storage and not during installation. Some units may ship with a template under them. This template should stay in place until the unit is to be installed.

Installation Procedure - .75" Threshold

1. At the time of installation, prepare the installation area in which the unit will sit by pouring a multipurpose thin set bed of which the pit walls become the boundary. Place the unit onto the mix and make sure the tub sits plumb and flush. This procedure will eliminate any voids under the tub. Too much mix can cause the floor to push upward during the cure and violate the drainage of the unit as well as bow the threshold of the unit. (See Figures 2 & 4)

2. In order to ensure proper draining of the unit, you must: a) Core drill a diameter of 10" and a depth of .5" on a concrete surface that is "pre-fabbed" around the drain pipe; or b) Box out a diameter of 10" and a depth of .5" in the poured slab around the drain pipe. Following these instructions will allow the floor surface of the unit to maintain its draft and allow the unit to drain properly (see Figure 5). This is absolutely necessary to allow for the depth of the drain pull that may go below the bottom of the threshold of the unit.

3. A unit with .75" barrier free threshold may be recessed or the outside floor may be built up .25" in order to allow the finished floor to come within .5" of the top of the threshold on any 60" barrier free (ADA) unit. The pit depression should be deep enough to allow for the specified finished floor. Detail and the pit dimensions should allow for the placement of the unit inside the pit. (See Figure 6)

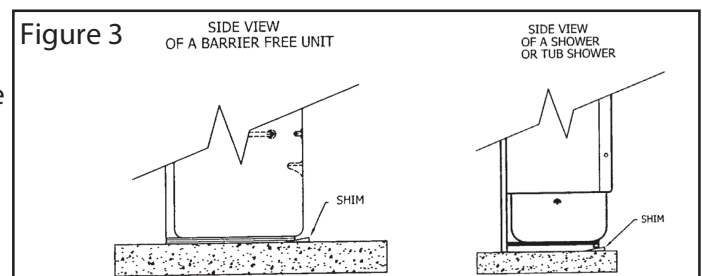
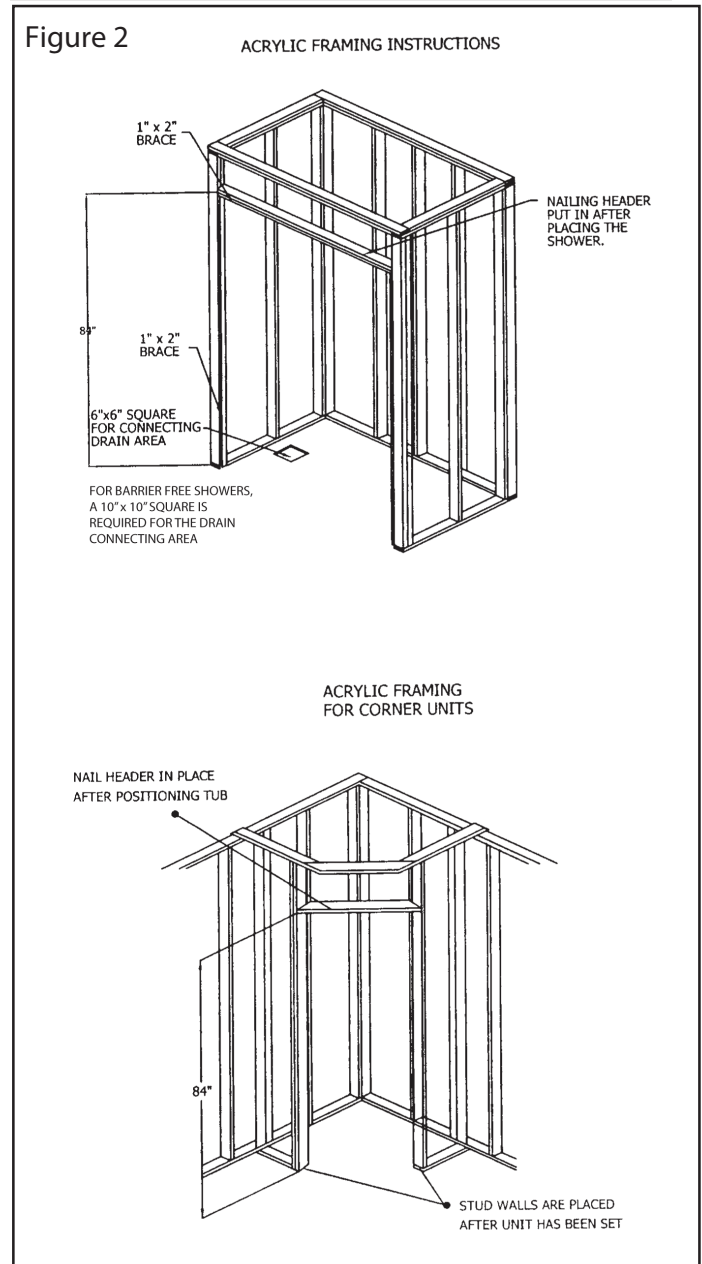
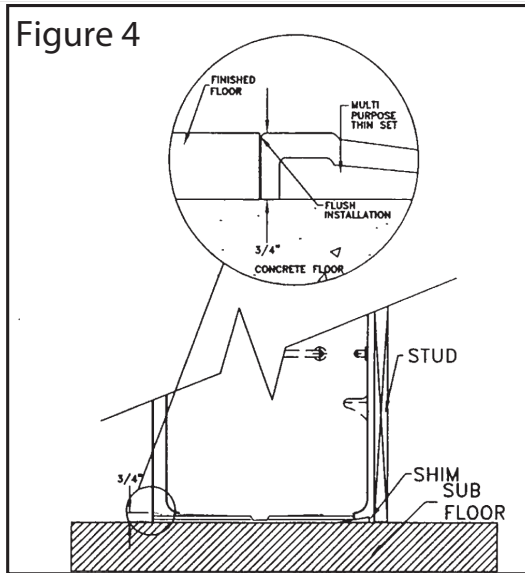

Figure 4



4. It is advised that all barrier free units should be designed with an outside floor drain to catch any over-spray of water that may escape the unit.

INSTALLATION PROCEDURE - 2" THRESHOLD

1. At the time of installation, prepare the pit in which the unit will sit by pouring a very wet multi-purpose thin set bed (applied with a .5" notched trowel) of which the pit walls become the boundary. Place the unit on to the mix and make sure the tub sits plumb and flush. This procedure will eliminate any voids under the tub. Too much mix could cause the floor to push upward and violate the drain-ability of the unit as well as bow the threshold (see Figure 7).

2. A unit with a 2" threshold must be recessed in order to allow the finished floor to come within .5" of the top of the threshold on any 36" barrier free (ADA) unit and level with the top of the threshold on any 60" barrier free (ADA) unit. The pit depression should be deep enough to allow for the specified finished floor detail and the pit dimension should allow for the placement of the unit inside the pit. (see Figure 8)

3. It is advised that all barrier free units should be designed with an outside floor drain to catch any over-spray of water that may escape the unit.

Figure 5

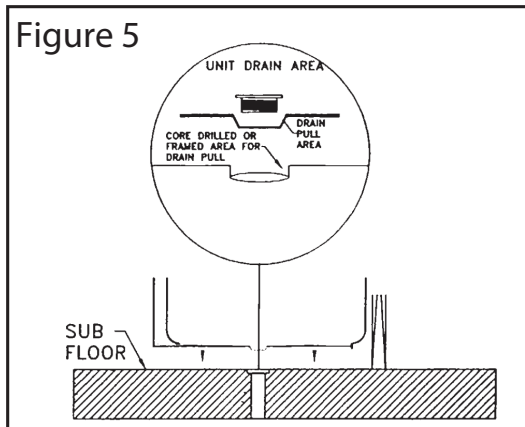

PREPARATION OF THE ACRYLIC UNIT FOR INSTALLATION

The barrier free special needs shower is a very sensitive unit to proper installation, therefore, it is very important that the following procedures are followed during remaining installation process to create the ideal barrier free access area. Prior to setting the product into the recessed pit, the pit must be prepared with a multipurpose thin set applied with a .5" notched trowel. This mixture needs to be wet in order to fill all areas under the base and flow with the draft of the base. When the pit has been prepared with the mixture, set the unit into the recessed pit. After the unit has been set into the thin set, it must be braced from the inside for 72 hours (until the mix is set) to insure proper drainage.

Figure 6

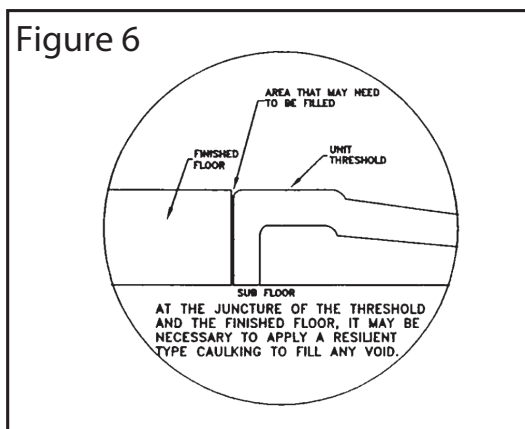

Standard Acrylic Units Installation Instructions

The following steps are proper procedure for the placement of the brace (see Figure 9):

1. Measure the distance between the drain and the ceiling in the inside of the unit. The distance should be between 80.5" and 80.75".

2. Cut 2 x 4 members for the top and the bottom. They should be 18" and 8" respectively.

3. Cut a 2 x 4 member the distance between the top and bottom less the thickness of the two pieces cut for the top and bottom.

4. Place the brace in the unit with the members for the top and bottom on each end of it. The brace with the ends should be a tight fit. In order to protect the surface of the unit, please place a towel or other soft object between the wood and the acrylic.

5. Level the unit in two directions, then attach the unit to the framing using the pre-drilled holes in the flanges. Check the floor for high spots that would prevent proper drainage.

6. Check the threshold to ensure it remains flat. If it has flexed upward, a brace should be placed from the top of the unit to the bowed section to hold it in place as the slurry cures.

7. Make the drain connection after the floor has been braced.

8. Remove the bracing after the mix has cured and check the floor for high spots.

Note: This unit is thoroughly tested in the plant to ensure its ability to drain water. Several tests are performed on each unit prior to it leaving the factory and all modified threshold units ship with a "false" bottom or upside down to prevent the drain from sitting on the floor. Failure to follow the above handling and installation procedures may cause improper drainage thus voiding the unit's warranty. It is advised that all barrier free units should be designed with an outside floor drain to catch any over-spray of water that may escape the unit.

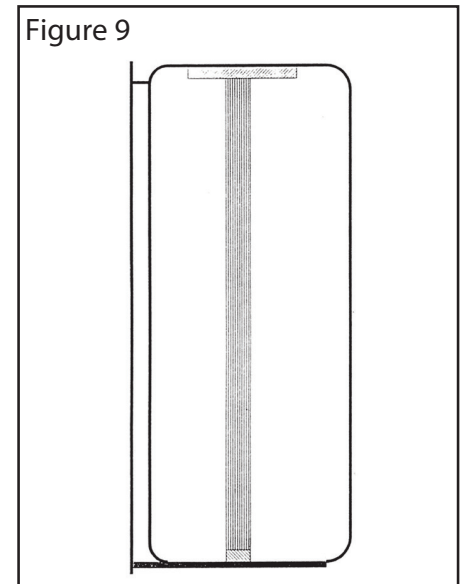
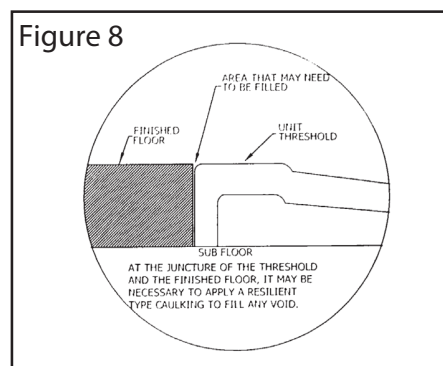
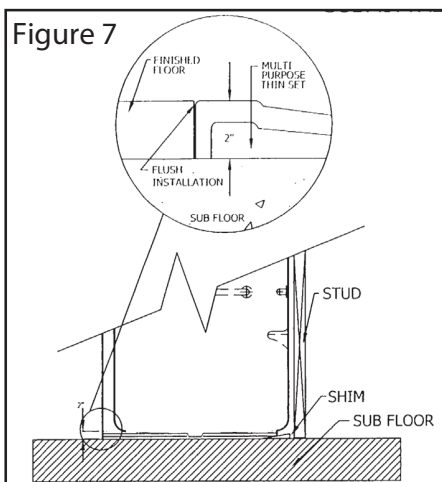

FLOORING DETAILS

See Figure 10 for 36" x 36" Threshold 0.5" - 2"

See Figure 11 for 60" Barrier Free

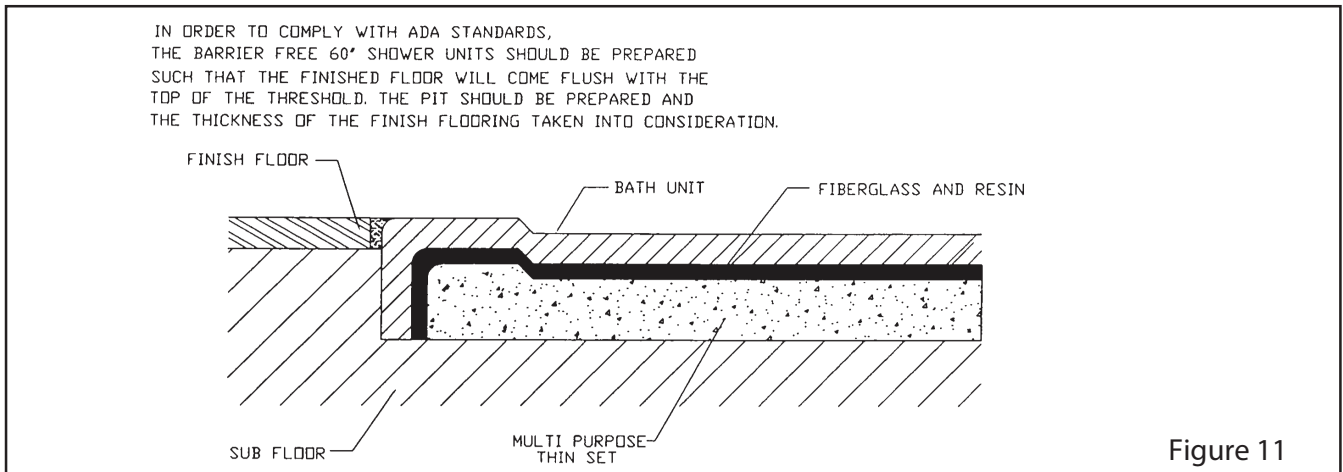
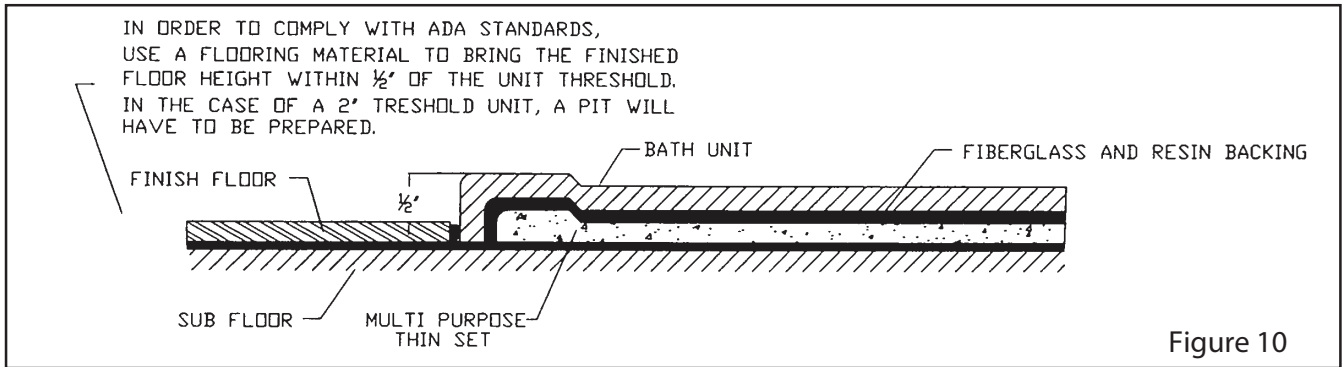

ACRYLIC EDGE INSTALLATION
See Figure 12

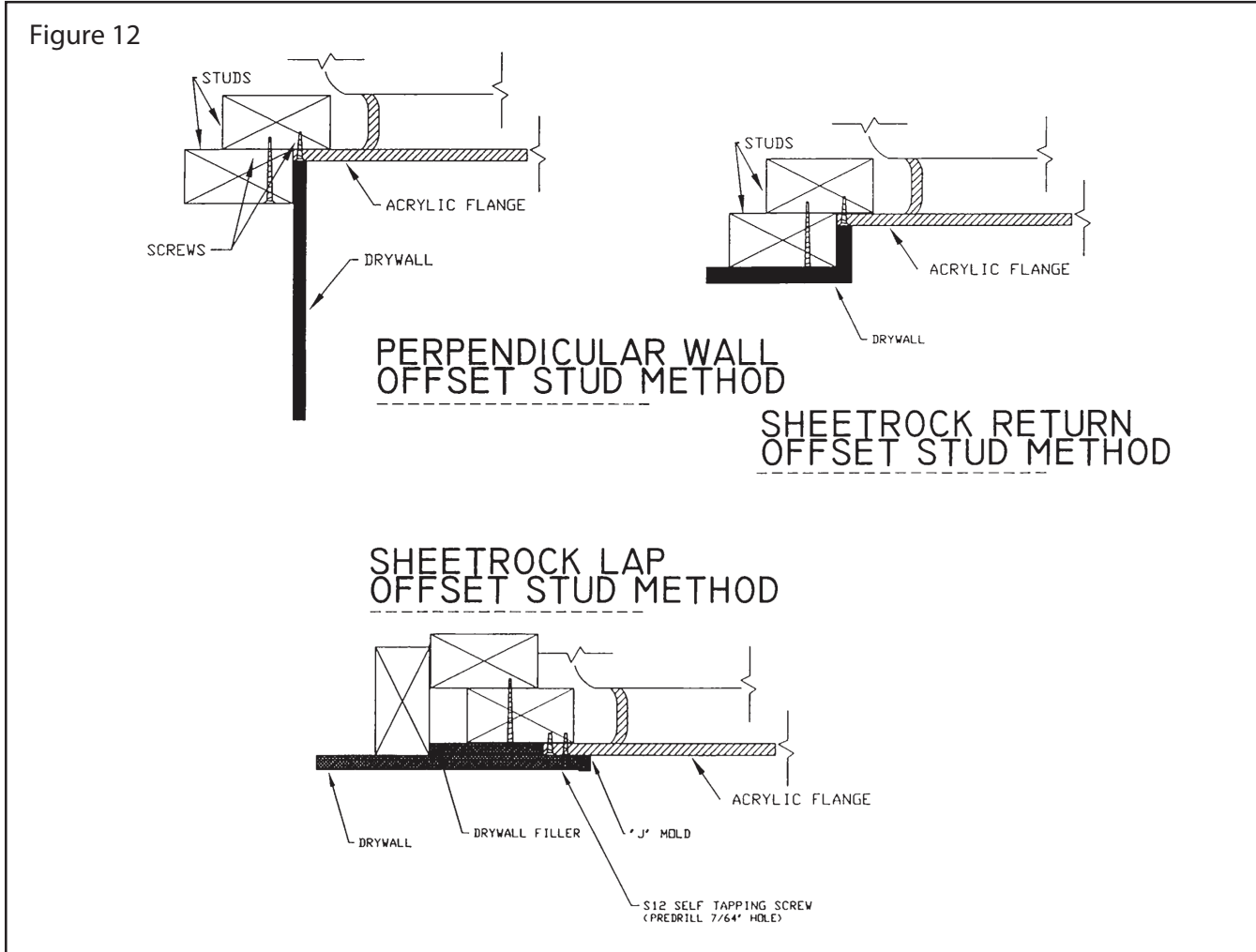

**DRYWALL INSTALLATION FOR
CORNER ACRYLIC SHOWER UNITS**
See Figure 13

Figure 13

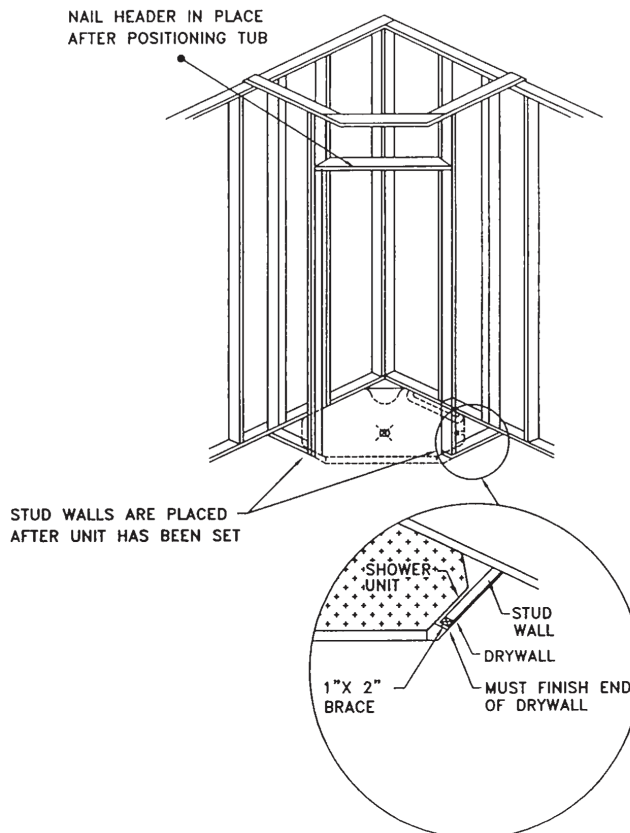
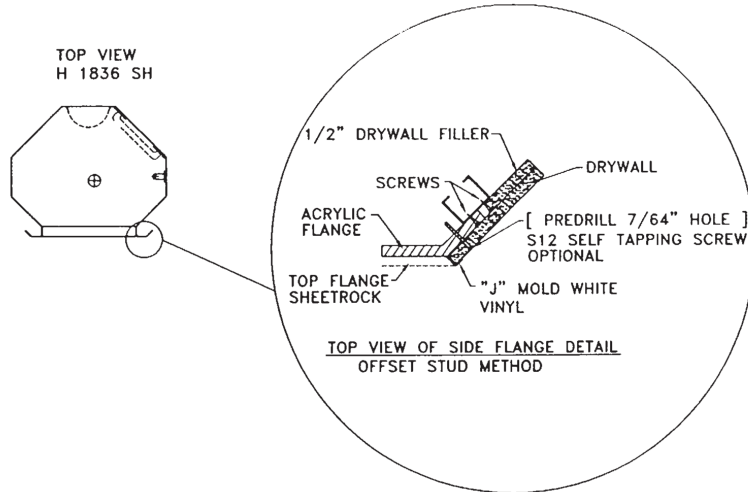

DRYWALL INSTRUCTIONS FOR
RECESSED RECEIVER ACRYLICS
See Figure 14

Figure 14

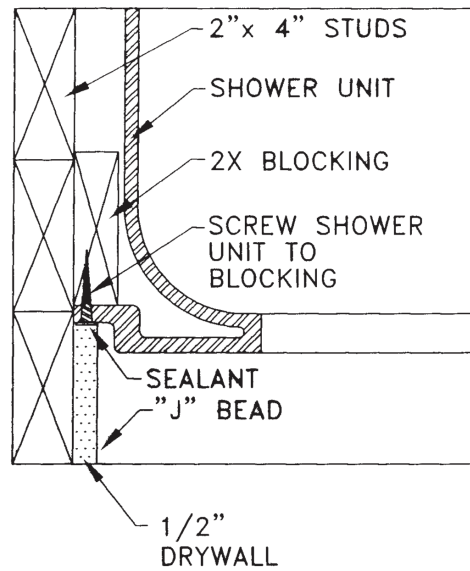

RECESSED RECEIVER FLANGE INSTALLATION 1

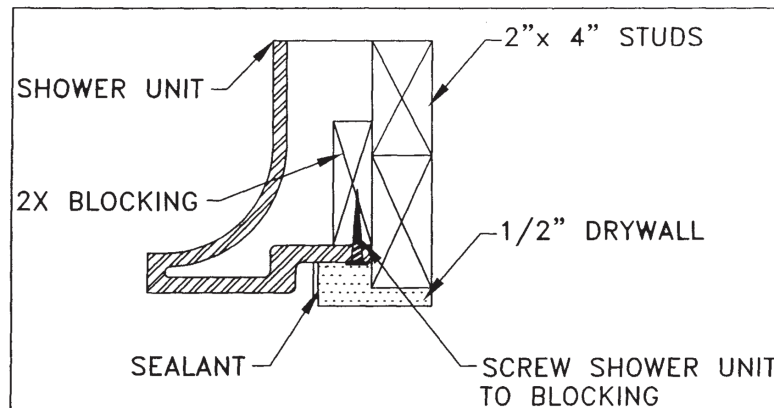

RECESSED RECEIVER FLANGE INSTALLATION 2



Standard Acrylic Units Installation Instructions

ACRYLIC UNITS INSTALLED IN CONCRETE BLOCK

See Figure 15

When placing the order, specify concrete block will be the framing material.

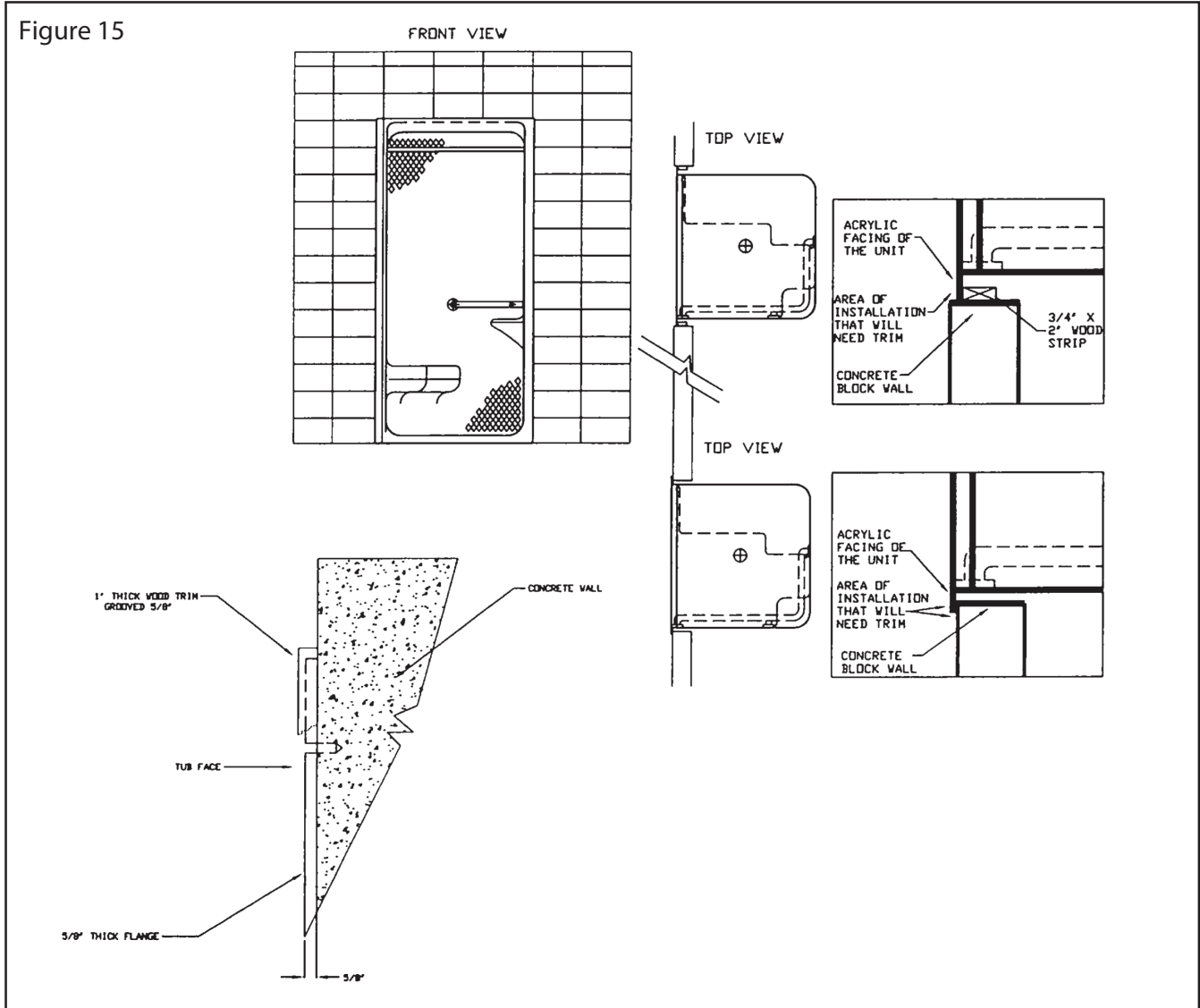



Standard Acrylic Units Installation Instructions

INSTALLATION OF OPEN TOP ACRYLIC

See Figures 16, 17 and 18

1. Frame in area 58.75" x 32.75" deep. The unit will be installed into this area and the backside of the front flanges will back up to the front stud and the back of the unit should intersect the rear studs.
2. Ensure the unit you have is the correct hand according to the plumbing in you installation area.
3. Place the unit into the installation area.
4. Plumb and level the unit.
5. Shim under the back leg of the unit on each end. Secure the shims in place either by nailing them to the construction floor or by caulking around them.
6. Secure the unit to the studs behind the front flanges and along the top back flange. Secure to the front studs **through the pre-drilled holes using screws.** Drill through the top back flange into the locations that intersect the studs. Use a bit that is slightly larger than the screw so as not to chip the surface. Do not drive nails through the flanges as this may chip the surface.

7. Mark the backside of the unit in the areas intended for the plumbing connections. Drill these marks from the backside with a small drill bit to the inside.

8. Using the small holes as pilot holes, drill from the inside of the units with proper hole sizes for the plumbing.

9. Make connections.

10. Water test connections.

11. Dry Walling: Dry walling the back flange is done by using two layers of drywall. One layer will butt up to the top of the rear flange. The next layer will overtop and extend down to the rear ledge. Dry walling the front of the unit is done by using two layers of drywall. One layer is used to butt against the front flange. The other layer will overlap over the front face of the unit.

A "J" mold will be used to finish out the overlapping edge of the unit. On the side walls, the dry wall will overlap the studs and extend down to the horizontal flange.

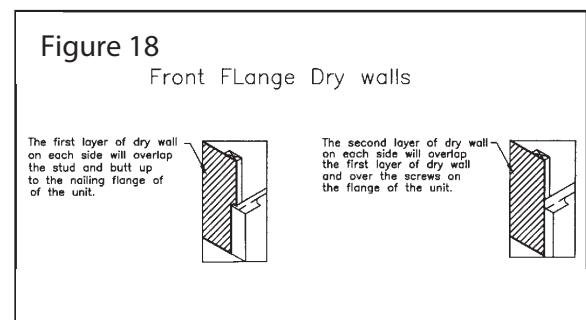
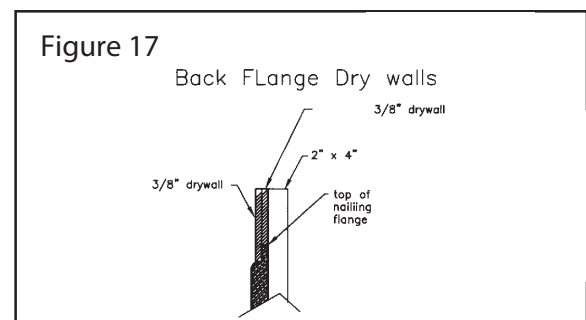
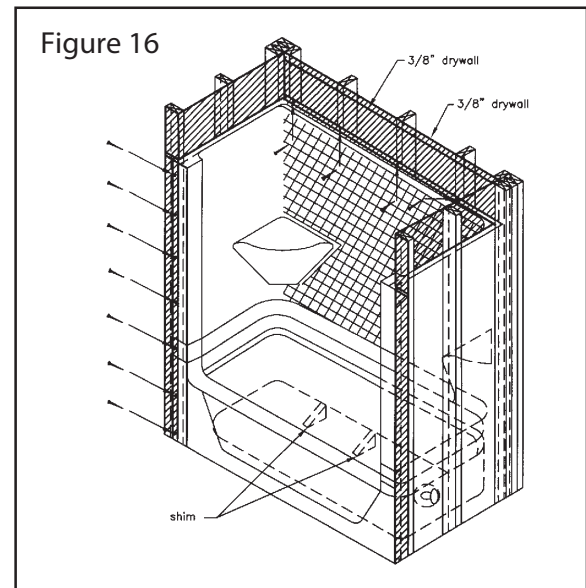



Standard Acrylic Units Installation Instructions

INSTALLATION OF AN S 4136 OPEN TOP ACRYLIC See Figures 19, 20 and 21

1. Frame in area 39" width x 37.5" deep. The unit will be installed into this area and the backside of the front flanges will back up to the front stud and the back of the unit should intersect the rear studs.

2. Ensure the unit you have is the correct hand according to the plumbing in your installation area.

2a. Follow the Barrier Free Installation Instructions.

3. Secure the unit to the studs behind the front flanges and along the top back flange. Secure to the front studs through the pre-drilled holes using screws. Drill through the top back flange into the locations that intersect the studs. Use a bit that is slightly larger than the screw so as not to chip the surface. Do not drive nails through the flanges or this may chip the surface.

4. Mark the backside of the unit in the areas intended for the plumbing connections. Drill these marks from the backside with a small drill bit to the inside.

5. Using the small holes as pilot holes, drill from the inside of the units with proper hole sizes for the plumbing.

6. Make connections.

7. Water test connections.

8. Dry Walling: Dry walling the back flange is done by using two layers of drywall. One layer will butt up to the top of the rear flange. The next layer will overtop and extend down to the rear ledge. Dry walling the front of the unit is done by using two layers of drywall. One layer is used to butt against the front flange. The other layer will overlap over the front face of the unit. A "J" mold will be used to finish out the overlapping edge of the unit. On the side walls, the dry wall will overlap the studs and extend down to the horizontal flange.

NOTE: Studs may need to be notched in around areas that may have screws or bolts.

NOTE: Due to the nature of the materials, dimensions may vary +/- 0.375".

Figure 19

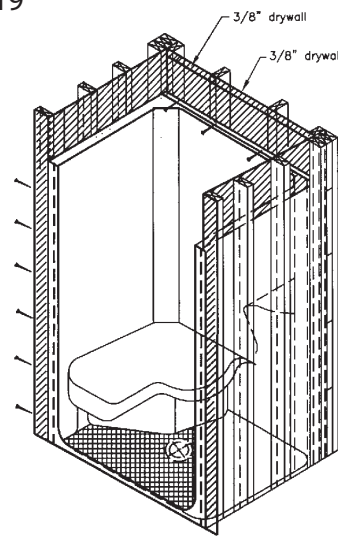

Figure 20

Back Flange Dry walls

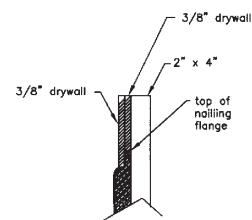
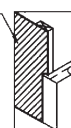

Figure 21

Front Flange Dry walls

The first layer of dry wall on each side will overlap the stud and butt up to the nailing flange of the unit.



The second layer of dry wall on each side will overlap the first layer of dry wall and over the screws on the flange of the unit.

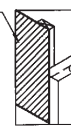



Standard Acrylic Units Installation Instructions

CARE AND CLEANING OF ACRYLIC UNITS

The surface of the unit is made of extremely durable and glossy acrylic, but the surface is vulnerable to the harsh conditions of a construction site. Please use caution with tools, boots and handling of the unit. It is recommended to save the cardboard from the packaging and place it on the floor to stand on while working on the unit.

The following non-abrasive cleaning products are recommended for cleaning your Praxis acrylic tub or shower unit:

- Ivory liquid, Dawn liquid, or any other liquid dish washing cleansers.
- A vinegar and water solution.
- Alcohol or mineral spirits may be used on difficult spots to clean.

If the unit received has a painted applied textured floor, please use the box which contained the unit as a mat in the unit while doing any plumbing in the unit. This will protect the painted surface and reduce clean-up to a minimum. If dirt does get on the painted surface use any liquid cleaner (Ajax, Pine Sol, etc.) to clean it safely without jeopardizing the textured surface.

Note: Never use paint thinner or acetone solutions to clean the unit as they will damage the glossy finish of the acrylic.

For any additional assistance or advice, contact the Customer Service Department of Praxis at 1.800.443.7269.

Customer Service | Technical Services | Warranty Services

American Bath Group
Address: 435 Industrial Road
Savannah, TN 38372
Phone: (800) 443-7269



AMERICAN ★ BATH GROUP

Hamilton is a Praxis brand
and a proud member of the
American Bath Group

Rev. 07.12.23