

# MS-2436

Mop Sin



Manufactured from Swanstone Composite

## FEATURES

- Manufactured from Swan's compression molded stone composite.
- Includes a 3" IPS cast brass drain and a 3" drain seal gasket (**MS-2411**).
- Dome strainer and lint basket.
- The most impact and stain-resistant mop sink available.
- Warranty: Limited 1-year - Residential  
Limited 1-year - Commercial

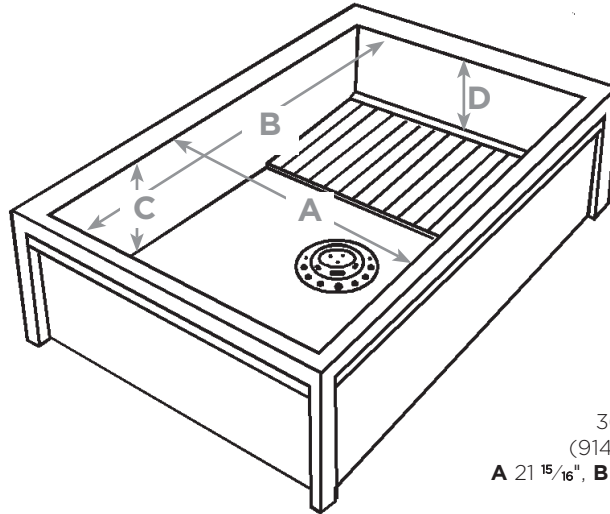

**MS-2436**  
36" D x 24" W  
(914 mm x 610 mm)  
**A** 21 <sup>15</sup>/<sub>16</sub>" **B** 33 <sup>15</sup>/<sub>16</sub>" **C** 9 <sup>1</sup>/<sub>8</sub>" **D** 8 <sup>1</sup>/<sub>2</sub>"

## SPECIFICATIONS

Model	Part	Nominal Dimensions	Ship Wt. Lb.	Ship FedEx	Carton Dims. In.	Cu. Ft.
MS-2436	MS02436WA	36" D x 24" W (914 mm x 610 mm)	63	FedEx	37 x 25 x 13	6.96

**Includes:** One sink plus one code-approved 3-inch IPS cast brass drain and a 3-inch rubber drain adapter (MS-2411).

**Packaging:** Packed in individual cartons.

## COLORS

### Solid Colors:

- Flock (033)

## ACCESSORIES

See page 130 for complete listing of all mop sink accessories.

## STANDARDS AND RATINGS

American National Standard Institute—ANSI Z124.6

International Association of Plumbing and Mechanical Officials (IAPMO)—Listed

CSA Test Standard B45.5

Uniform Plumbing Code (UPC)

## MAINTENANCE AND CLEANING INFORMATION

Clean regularly with common household liquid cleaners and a sponge or soft cloth. For hard water stains, scale removers can be used. **Do not** use abrasive cleaners or metal scouring pads.

## SUPPORT DOCUMENTS

Installation instructions available at [swanstone.com](http://swanstone.com).

**MADE IN USA**