

# TS6032-3W

inches

## TUB SHOWERS

60 x 31 1/2 x 73



### COLOR AND TRIM OPTIONS

Stock

White

### FEATURES

- Tub Shower
- Smooth wall finish
- Ergonomic backrest
- Ample shelf capacity
- Slip-resistant textured bottom
- Left or right hand drain
- AcrylX<sup>®</sup> applied acrylic surface
- Lifetime limited warranty

### OPTIONS

- Factory installed assisted care grab bars
- FHA Reinforcement - For Future Grab Bars

### CODE COMPLIANCE

- HUD/FHA Design Manual Requirement 6\*
- CSA B45.5-11/IAPMO Z124

\*When ordered with factory installed reinforcement, product will meet or exceed the minimum coverage area and load requirements of ANSI section 609.8, when grab bars are installed within the reinforced area.

**FLORESTONE**  
MADE FOR THE TRADE



 **MADE IN USA**  
WITH GLOBAL MATERIALS

florestone.com

### TS6032-3W

60 x 31 1/2 x 73 inches

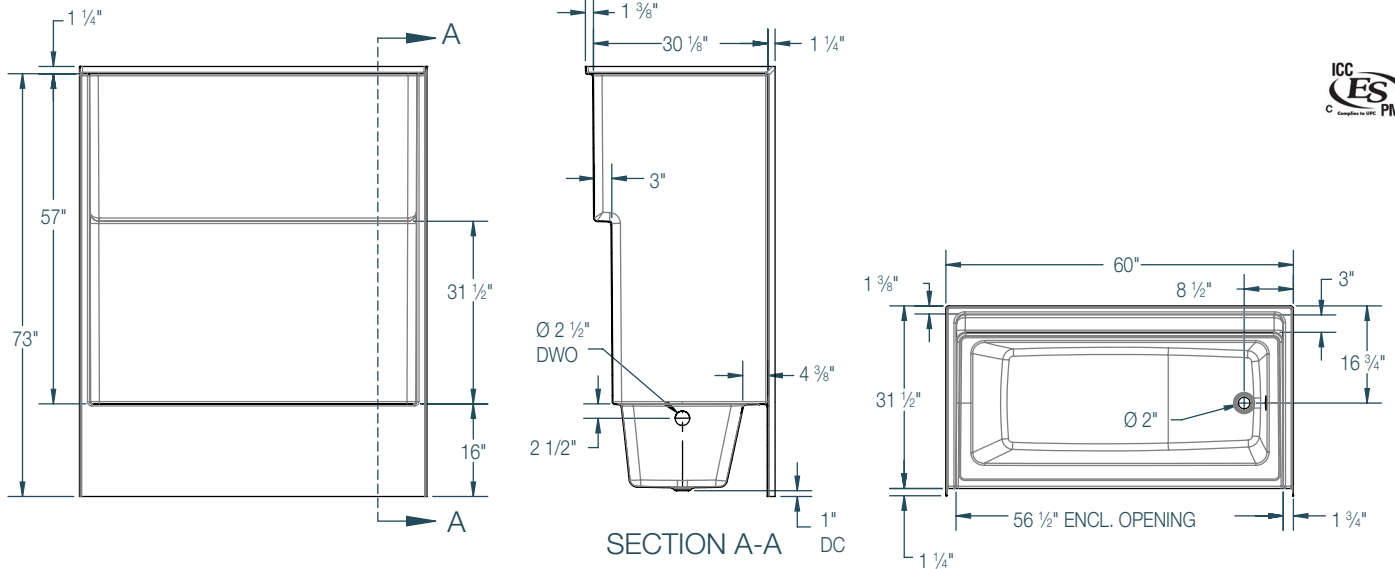

**FEATURES** Dimensional Tolerance  $\pm 1/4"$ . Dimensions needed for site preparation should be measured from the unit. American Bath Group assumes no responsibility for preparatory work.

Model #	Material	Wall Finish	Jets	Motor	Controls	Drain	Net Wt.	Pkg. Wt.
Tub Shower #TS6032-3W	AcrylX®	Smooth	-	-	-	LH or RH	135	139

#### DIMENSIONS

Specifications	inches
Width: Overall / Net	60 / 56 1/2
Depth: Overall / Net	32 3/4 / 31 1/2
Height: Overall / Net	74 1/4 / 73
Enclosure Opening	56 1/2
Skirt Height	16
Drain Rough-In (from Back Wall)	16 3/4
Drain Rough-In (from Side Wall)	2 3/4
Drain: Diameter / Clearance	2 / 1

#### FRAMING DIMENSIONS inches

Type	D Depth	W Width	H Height	A	B	C
Alcove	32 3/4	60 1/4	-	Box Out	2 3/4	16 3/4

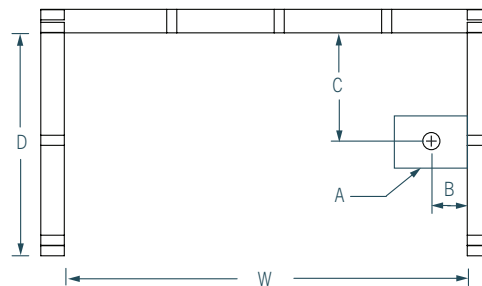

#### SUMP DATA

Top of Drain to Bottom of Overflow	Capacity to Overflow gal	Min. Operating Capacity gal	WIDTH @ centerline		DEPTH @ centerline	
			Top	Bottom	Top	Bottom
10 5/8	37.1	-	50 7/8	44 7/8	20 7/8	17 7/8

Rev. 03.19.26

