



GSP0311

CAST IRON SUMP PUMP

FEATURES

- Cast iron body
- Corrosion-resistant fasteners
- Thermoplastic impeller and cover
- Oil-cooled motor
- Motor is permanently lubricated for extended service life and is powered for continuous operation.
- Complete unit is heavy duty, portable, and compact
- Built-In Vent Hole: Prevent air-binding with no added labor
- Upper and lower sleeve bearings
- Premium mechanical seal design

APPLICATIONS

Specially designed for the following uses:

- Basement draining
- Water transfer
- Dewatering
- Filtered Effluent

SPECIFICATIONS

- Discharge size: 1 ½" NPT.
- Capacities: to 43 GPM.
- Maximum head: 22 foot TDH
- Maximum solids handling: ½" spherical
- Temperature: 130° F (54° C)
- Mechanical seal: Silicon Carbide/Carbon/BUNA

MOTOR

- 1/3 HP, 115 V, 60 Hz, single phase, 10 amps maximum, 1550 RPM
- Automatic vertical float, manual float switch option
- Shaded pole motor type
- Built-in thermal overload protection
- Oil filled design
- Power Cord: 9 foot standard length with NEMA 5-15P plug

AGENCY LISTINGS



Tested to UL778 CAN 22.2 by
CSA International (Canadian Standards Association)

PERFORMANCE RATINGS

Total Head (feet of water)	GPM	GPH
5	42	2520
10	35	2100
15	26	1560
20	11	660

GSP03 PERFORMANCE CURVE

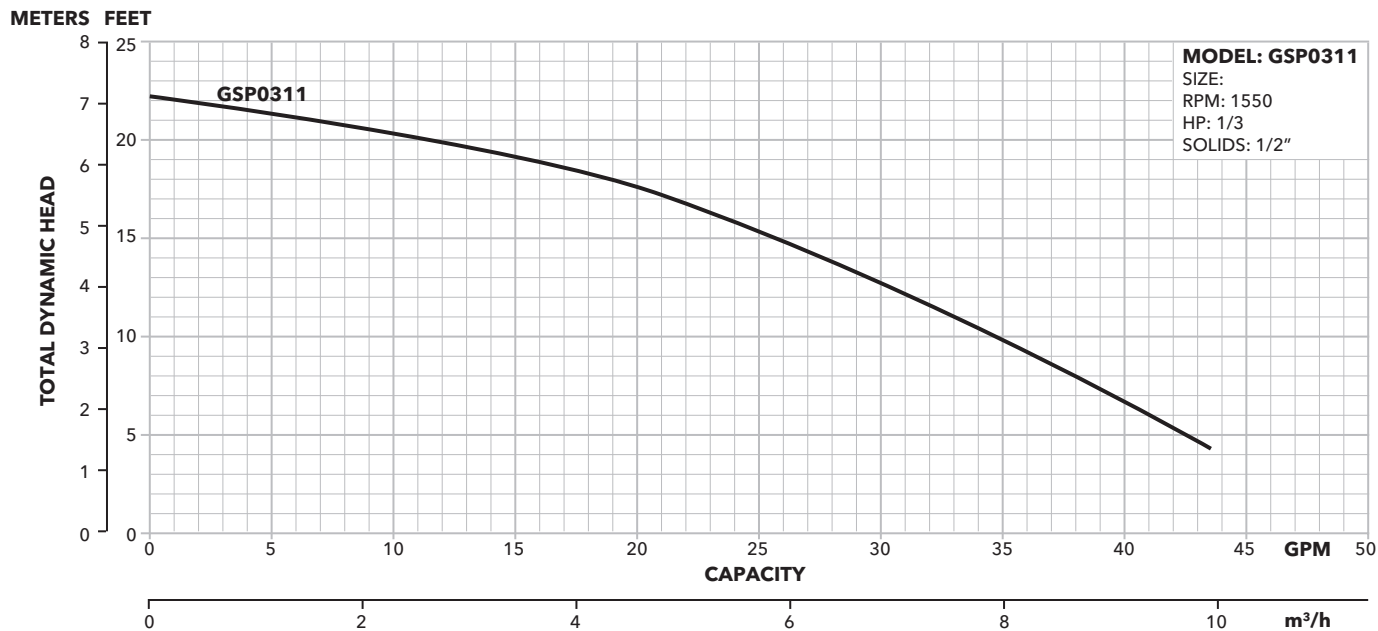

MODEL INFORMATION

Model	Part No.	HP	Volts	Amps	Minimum Circuit Breaker	Phase	Float Switch Style	Cord Length	Discharge Connection	Min. On Level	Min. off Level	Min. Basin Diameter	Max. Solids Size	Shipping Weight
GSP	GSP0311	1/3	115	10	15A	1	Vertical	9'	1 1/2"	7 1/4"	3 1/2"	1'	1/2"	27 lbs
GSP	GSP0311M	1/3	115	10	15A	1	Not Supplied	9'	1 1/2"	-	-	1'	1/2"	27 lbs

COMPONENTS

Item No.	Description
1	Float Bracket
2	Float Rod
3	Float
4	Base
5	Seal Housing
6	Plug
7	Motor Dome
8	Mechanical Switch Housing
9	Handle

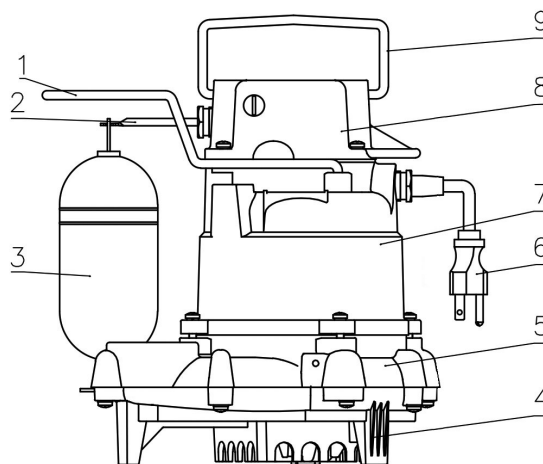

DIMENSIONS

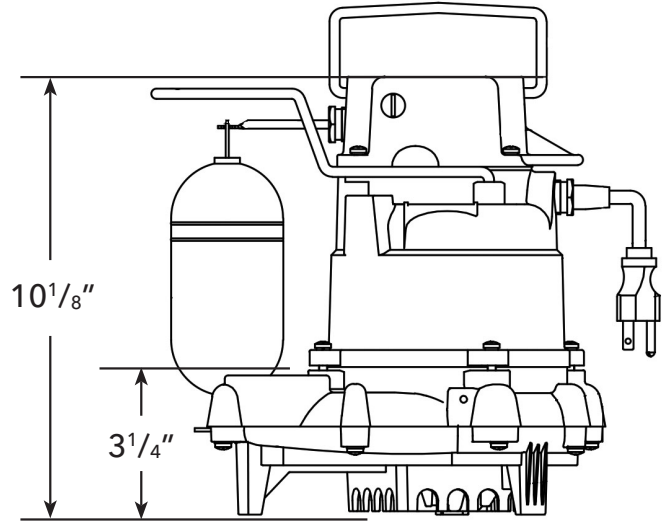
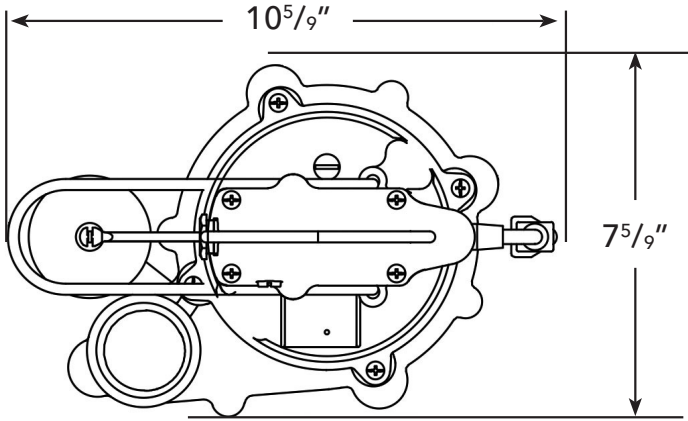

REPAIR PARTS

Part Description	Part No.	Part
GSP-SWITCH	9K701	Switch Assembly with Gasket and Hardware

xylem
Let's Solve Water

Xylem Inc.
2881 East Bayard Street Ext., Suite A
Seneca Falls, NY 13148
Phone: (866) 325-4210
Fax: (888) 322-5877
www.gouldswatertechnology.com

Goulds is a registered trademark of Goulds Pumps, Inc. and is used under license.
© 2016 Xylem Inc. BGSP03 R1 January 2016