

CENTRIFUGAL PUMPS

SELF-PRIMING FTT 20-40



FEATURES

- Volute: Cast iron construction with reinforced ribs for added strength; clean-out cover with wing nuts for quick access; tapped openings for priming, venting, and draining; built-in check valve with threaded NPT suction inlet prevents siphoning and facilitates priming
- Impeller: Two-vane, enclosed cast iron construction capable of handling spherical solids; unique design eliminates the need for a wear plate
- Mechanical Seal: Standard carbon/ceramic faces; FKM elastomers; 300 series stainless steel components
- Bearing Frame: Heavy, sealed bearings; keyed stainless steel shaft for belt or direct drive systems
- Mounting: Horizontal position



SPECIFICATIONS

- Capacities to 740 gpm
- Heads to 140 feet
- 75 psi maximum working pressure
- 212 °F maximum temperature
- Clockwise rotation when viewed from motor end
- NPT pipe connections

Discharge	Suction
2	2
3	3
4	4

APPLICATIONS

- Irrigation
- Construction
- Mining
- Commercial
- Municipal
- Light Industrial
- Water Truck

CENTRIFUGAL PUMPS

SELF-PRIMING FTT 20-40



PERFORMANCE

FTT-20

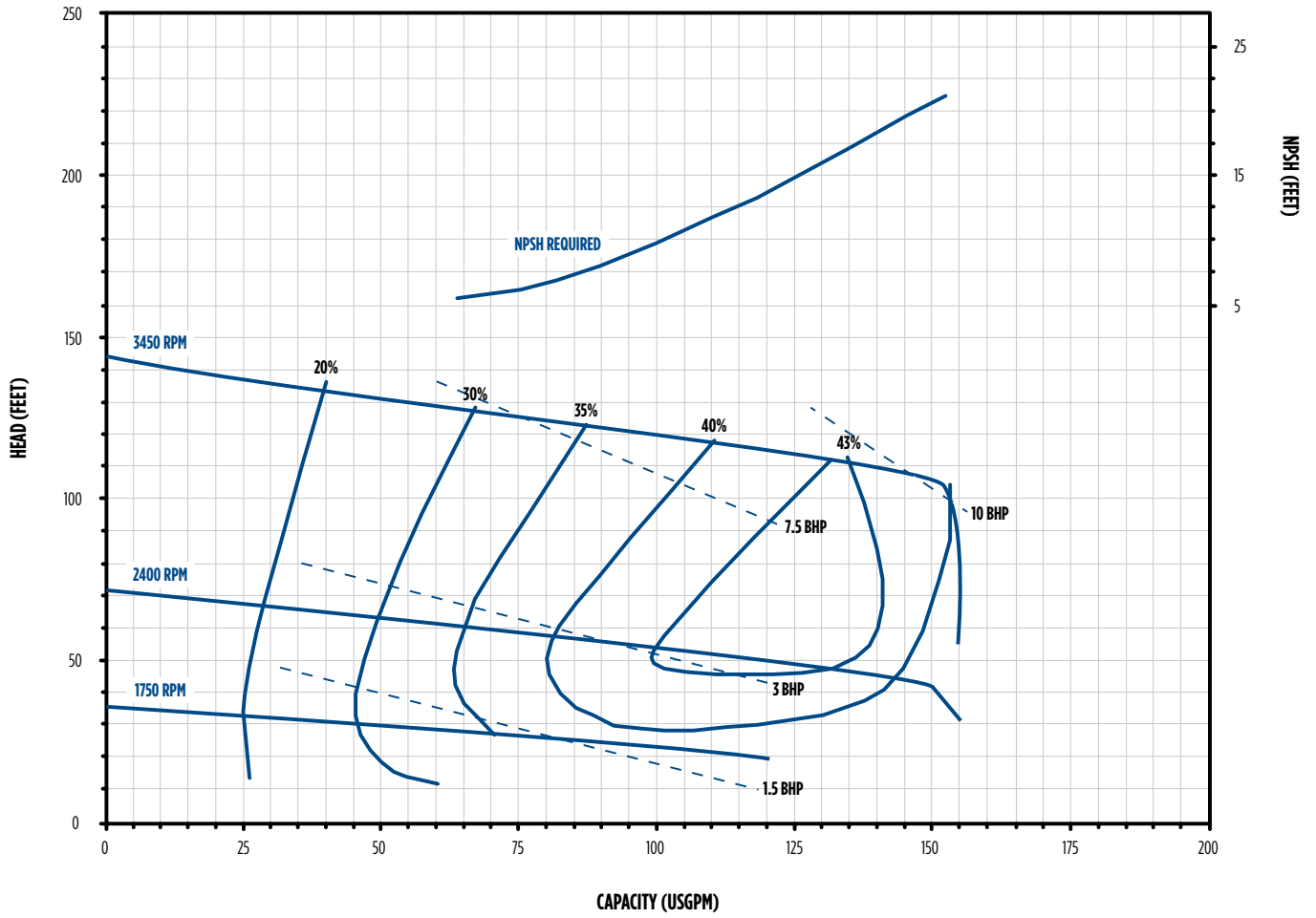

CENTRIFUGAL PUMPS

SELF-PRIMING FTT 20-40



PERFORMANCE

FTT-30

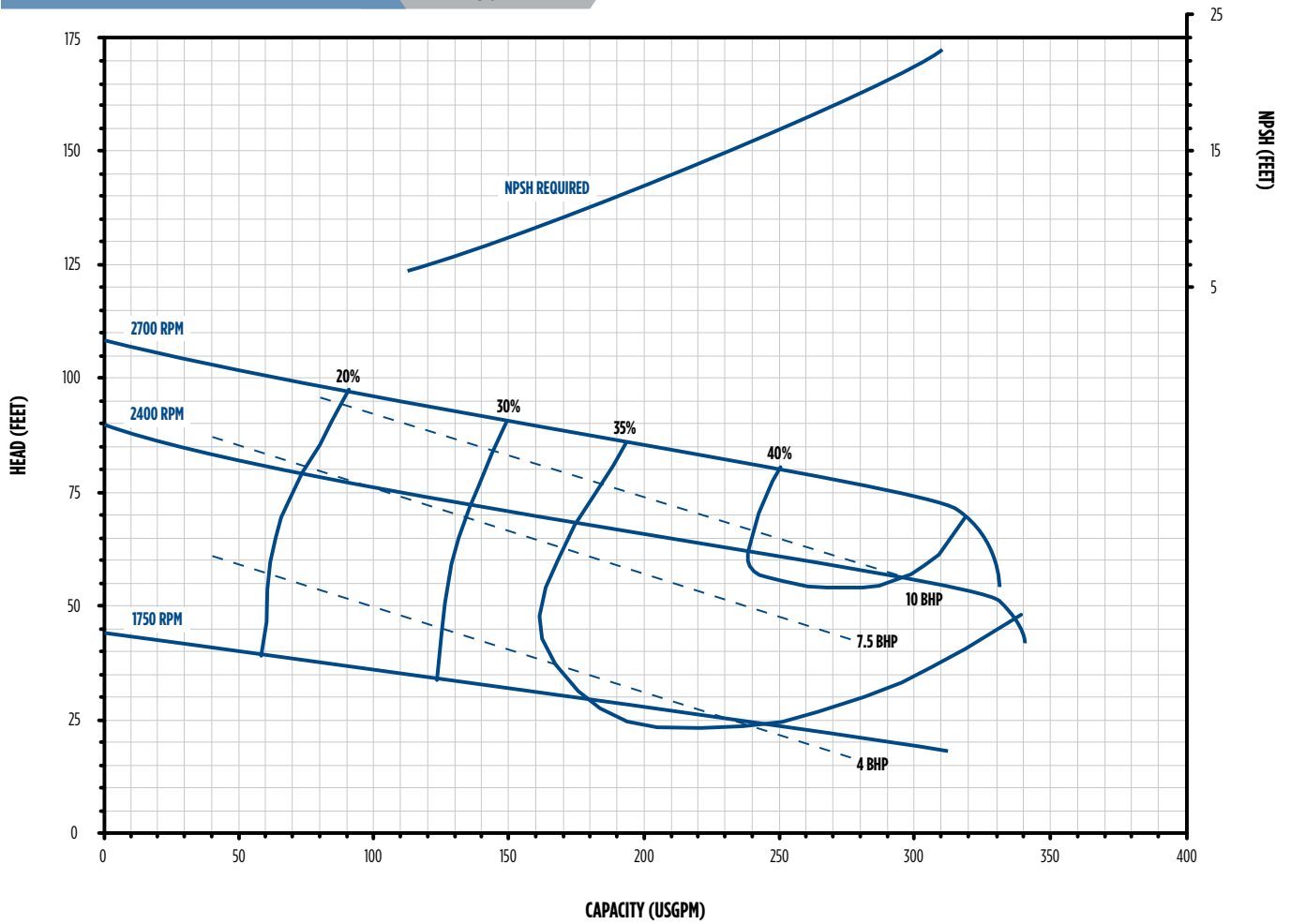

CENTRIFUGAL PUMPS

SELF-PRIMING FTT 20-40



PERFORMANCE

FTT-40

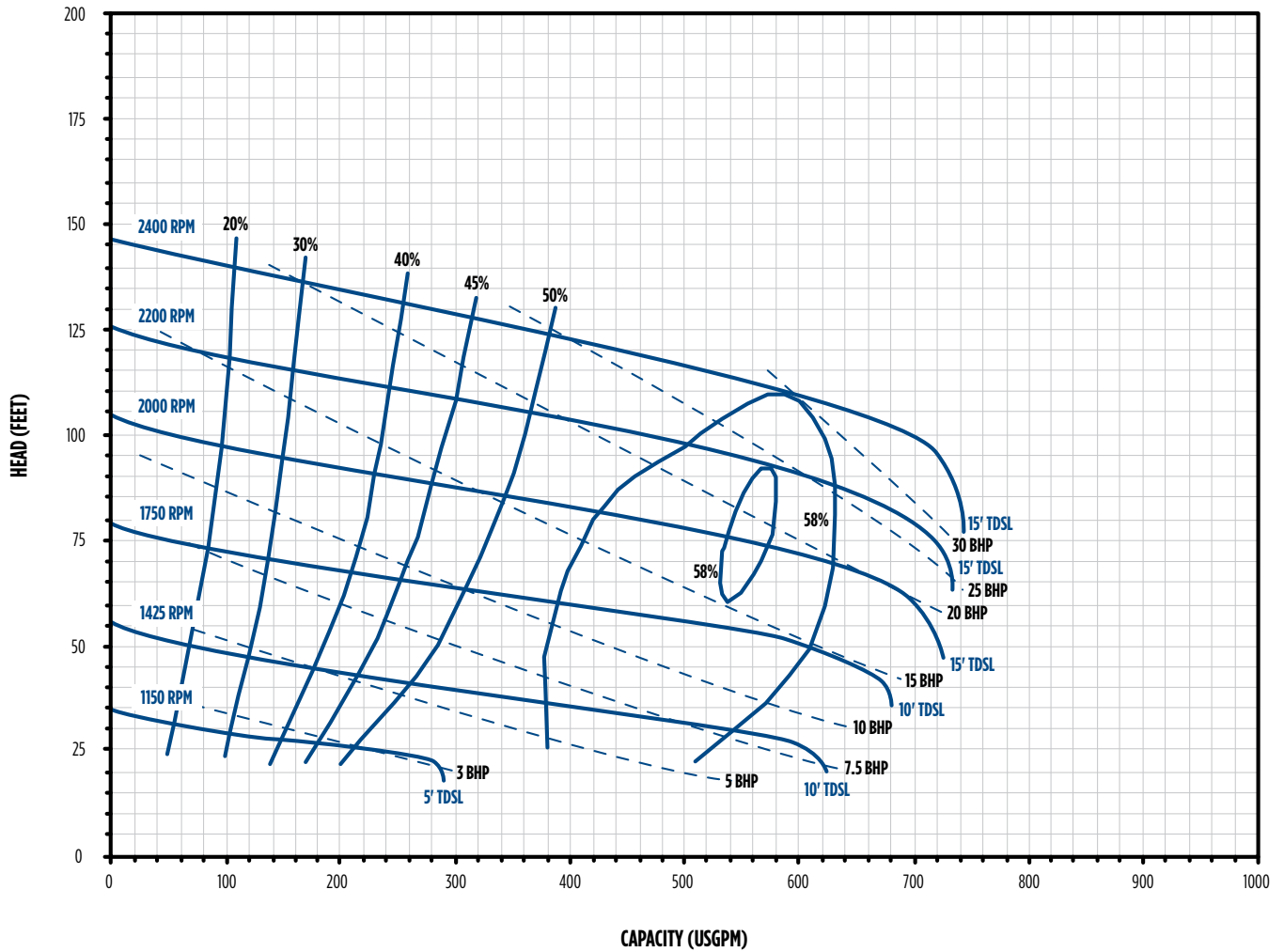

CENTRIFUGAL PUMPS

SELF-PRIMING FTT 20-40



DIMENSIONS

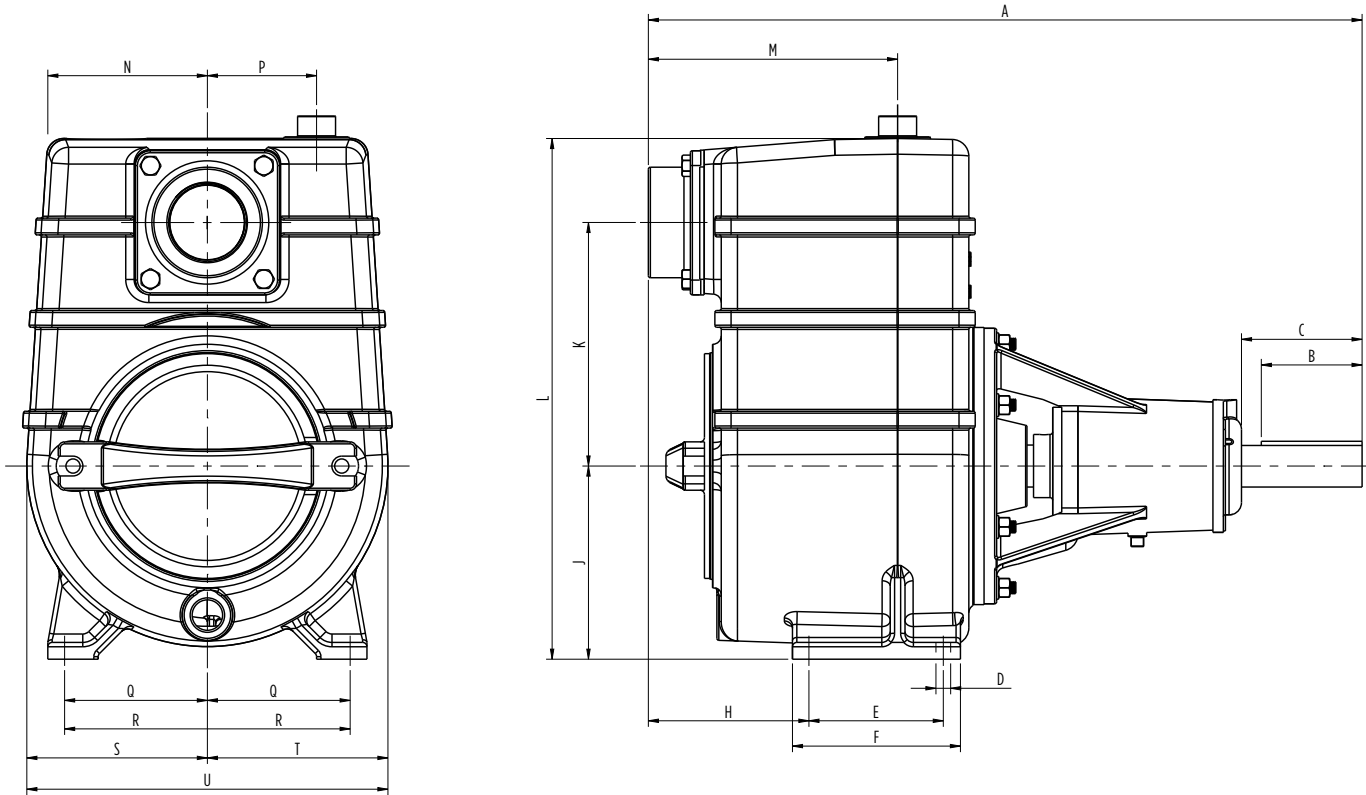

Model	Group	Suc. x Dis. (NPT)	Dimensions (in)																	Shaft Dia. (in)	Keyway (in)	
			A	B	C	D	E	F	H	J	K	L	M	N	P	Q	R	S	T			U
FTT-20	801	2 x 2	21.25	3.00	3.59	.44	4.00	5.00	4.78	5.75	7.25	15.50	7.42	4.75	3.25	4.25	8.50	5.38	5.38	10.75	1.250	1/4 x 1/4
FTT-30	802	3 x 3	24.71	3.00	3.42	.56	4.75	6.00	6.51	6.91	10.73	20.13	9.45	5.56	-3.75	5.38	10.75	6.38	6.38	13.31	1.250	1/4 x 1/4
FTT-40	803	4 x 4	30.06	3.00	3.57	.56	7.25	9.00	6.64	9.00	14.00	26.50	11.76	7.00	-4.76	7.75	15.50	8.88	8.88	17.76	1.625	3/8 x 3/8

NOTE: Dimensions are for estimating purposes only.

ORDERING INFORMATION

Model	Pump Size (Dis. x Suc.)	Order No.	Weight (lbs)	Solid Size (in)
FTT-20	2 x 2	90240002	129	1-1/8
FTT-30	3 x 3	90240003	190	2
FTT-40	4 x 4	90240004	420	3

CENTRIFUGAL PUMPS

SELF-PRIMING FTT 20-40



MATERIALS AND PARTS

Fig. No.	Part Description	Part No.			Materials
		FTT-20	FTT-30	FTT-40	
1	Pump Case	305454001	305454002	305454003	Cast iron, ASTM-A48 CL30
2	Impeller	305454004	305454005	305454006	Cast iron, ASTM-A48 CL30
3	Seal Plate	305454007	305454008	305454009	Cast iron, ASTM-A48 CL30
4	Wear Ring	305454010	305454011	305454012	Ductile iron
5	Shaft	305454013	305454014	305454015	7M-212SST
16	Ball Bearing*	305463034	305463035	305463036	Misc.
35	Shaft Key	305454016		305454017	1018 CRS
38	Bearing Nut	305463037	305463038	305463039	300 series stainless steel
39	Bearing Lock Washer	305463040	305463041	305463042	Zinc-plated steel
72	Check Valve	305454018	305454019	305454020	Cast iron, ASTM-A48 CL30
73A	Top Weight, Check Valve	305454021	305454022	305454023	Cast iron, ASTM-A48 CL30
73B	Bottom Weight, Check Valve	305454024	305454025		Cast iron, ASTM-A48 CL30
75	T-Handle Fasteners	305454026		305454027	Cast iron, ASTM-A48 CL30
78	Clean-Out Cover	305454028	305454029	305454030	Cast iron, ASTM-A48 CL30
79	Transmission Head	305454031	305454032	305454033	Cast iron, ASTM-A48 CL30
80	Bearing Cover	305454034	305454035	305454036	Cast iron, ASTM-A48 CL30
81	Seal Cover	305454037	305454038	305454039	Cast iron, ASTM-A48 CL30
90	Mechanical Shaft Seal	305463043		305463044	Carbon/ceramic/FKM/stainless steel
100A	Case Gasket	305454040	305454041	305454042	Nitrile
100B	Flapper Valve	305454043	305454044	305454045	Neoprene
100C	O-ring, Volute	305463045	305463046	305463047	Nitrile
500A	Pipe Plug, NPT (3 pack)	305463048	305463049		CAD-plated steel
500B	Pipe Plug, 3/4" (3 pack)	305463050			CAD-plated steel
500C	Pipe Plug, 1/4" (4 pack)	305463020		n/a	CAD-plated steel
500D	Pipe Plug, 1/8" (3 pack)	305463051		n/a	CAD-plated steel
510	Impeller Hex Bolt	305463052	305463053	305463054	300 series stainless steel
520	Impeller Washer	305453006	305454046	305454047	Aluminum plate
530A	Washer, T-handle	305463055		n/a	Zinc-plated steel
530B	Flapper Bolt	305463056	305463057	305463058	Zinc-plated steel
530C	Hex Nut (8/6 pack)	305463033	305463059		Zinc-plated steel
530D	Lock Washer, 3/8" (8/6 pack)	305463032	305463060		Zinc-plated steel
530E	Nut, Flapper	305463061		305463062	Zinc-plated steel
530F	Washer, Flapper	305463063		n/a	Zinc-plated steel
530G	Valve Hex Cap Screw (4 pack or 8 pack)	305463064		305463065	Zinc-plated steel
530H	Washer, Bearing Cover	305463066		305463067	Zinc-plated steel
530J	Bolt, Bearing Cover	305463068		305463069	Zinc-plated steel
531A	Threaded Stud, Cover (6 pack)	305463070	305463071	305463072	Zinc-plated steel
531B	Threaded Stud, Transmission (6 pack)	305463031	305463073		Zinc-plated steel
532	Set Screw	305463074		305463075	Zinc-plated steel

* Kit contains only one ball bearing.



Franklin Electric