

TankMixer™ water heater tank mixing valve

520 series



Function

The Caleffi TankMixer™ 520_AX series kit combines a three-way thermostatic mixing valve with a cold water cross and flexible pipe for easy installation directly on a typical gas-fired water heater and other water heaters that now comply with the National Appliance Energy Conservation Act (NAECA). The TankMixer™ maintains the desired output temperature of the mixed water supplied at a constant set value compensating for both temperature and pressure fluctuations of the incoming hot and cold water. The mixing valve hot inlet port closes tight to prevent temperature creep in recirculation applications. Also available as body only, for a wide variety of separately-sourced end connections, the angle style body design offers improved fluid dynamics for better performance and reduces installation labor and materials, eliminating a piping elbow in typical installations.

The valve has been specifically certified to ASSE 1017 and Low Lead Plumbing Law by ICC-ES.



Product range

52050_AX series	Kit containing adjustable three-way thermostatic mixing valve, angle body with cold water cross with check valve and flexible connector pipeconnections 3/4" NPT female to water heater; 3/4" sweat, press, and NPT male union mix outlet/cold water inlet
52051_AX series	Kit containing adjustable three-way thermostatic mixing valve with mixed outlet temperature gauge, angle body with cold water cross with check valve and flexible connector pipeconnections 3/4" NPT female to water heater; 3/4" sweat, press, and NPT male union mix outlet/cold water inlet
520051A	Adjustable three-way thermostatic mixing valve, angle style body only for field installed connection fittings, source separatelyconnections 1" male union

Technical specifications

Materials

- Valve body:	DZR low-lead brass
- Cold water cross body:	DZR low-lead brass
- Shutter, seats and slide guides:	PSU
- Springs:	stainless steel
- Seals:	EPDM
- Adjustment knob	ABS
- Large ID flexible pipe:	stainless steel
- Recirculation port plug:	low-lead brass

Performance

Suitable fluids:	water
Setting range:	95–150° F (35–65° C)
Tolerance:	±3° F (±2° C)
Max. working pressure (static):	150 psi (10 bar)
Max. working pressure (dynamic):	75 psi (5 bar)
Max. hot water inlet temperature:	195° F (90° C)
Max. inlet pressure ratio (H/C or C/H) for optimal performance:	2:1

Minimum temperature difference between hot water inlet and mixed water outlet for optimal performance: 27° F (15° C)
 Minimum flow to ensure optimal performance: 0.5 gpm (2 L/min)

Certifications

- ASSE 1017/CSA B125.3, certified by ICC-ES, file PMG-1357.
- NSF/ANSI 372-2011, Drinking Water System Components- Lead Content Reduction of Lead in Drinking Water Act, California Health and Safety Code 116875 S.3874, Reduction of Lead in Drinking Water Act, certified by ICC-ES, file PMG-1360.

Connections

- to water heater:
 - NPT female union: 3/4"
- to mix temperature outlet and cold water inlet
 - sweat union: 3/4"
 - press union: 3/4"
 - NPT male union: 3/4"
- recirculation inlet port in cross:
 - NPT female (plug included) 1/2"

Dimensions

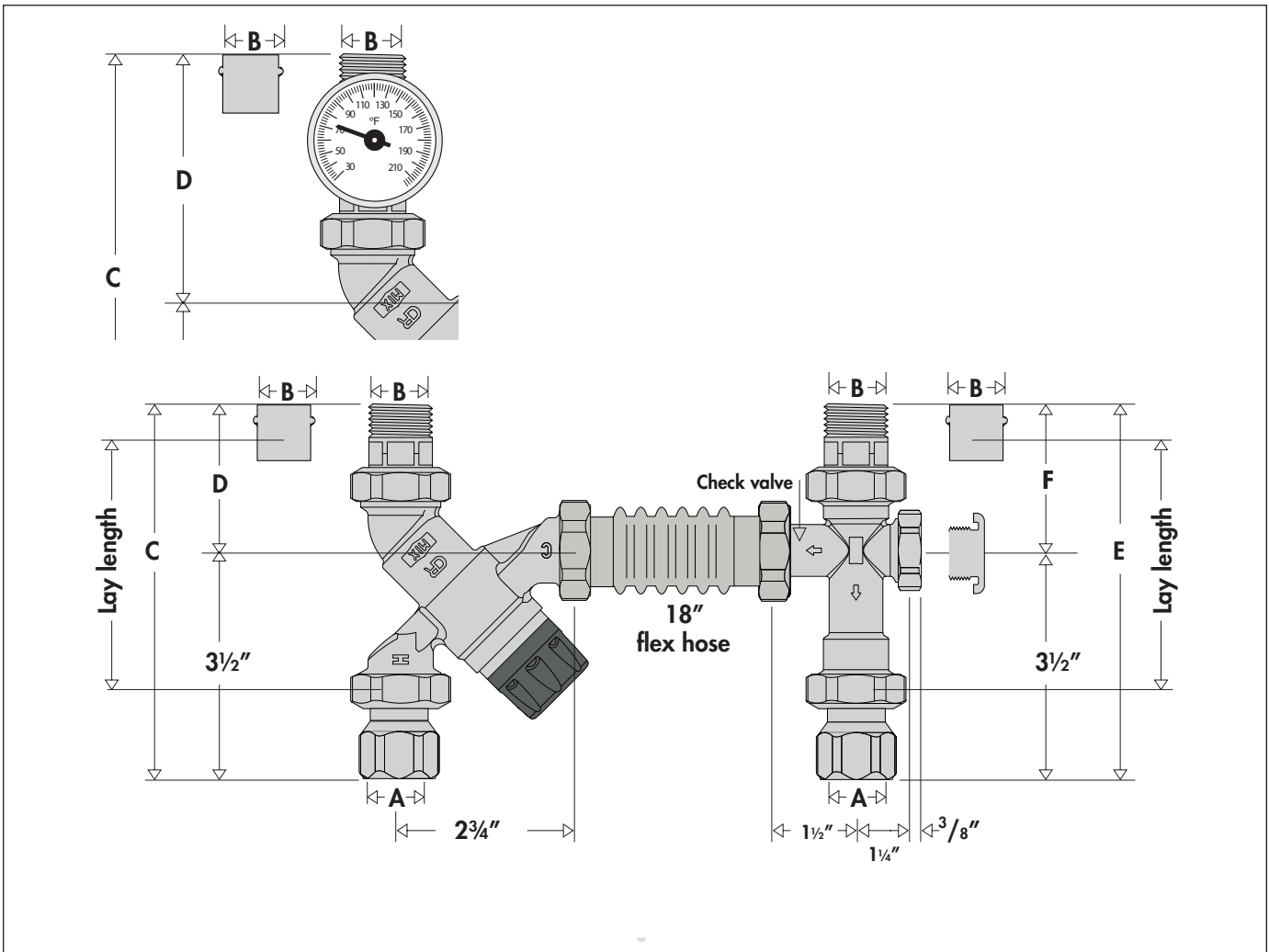

No temperature gauge.

Code	A	B	C	D	E	F	Wt. (lb.)
520500AX	3/4" nptf	3/4" nptm	5 9/16"	2 1/4"	5 5/8"	2 1/4"	2.4
520506AX	3/4" nptf	3/4" press	5 13/16"	2 9/16"	5 7/8"	2 9/16"	2.4
520509AX	3/4" nptf	3/4" swt	5 1/2"	2 3/16"	5 1/2"	2 3/16"	2.4

Lay length (hot inlet to mix outlet) for press: 3 3/8"; for sweat: 3 3/8".

With temperature gauge.

Code	A	B	C	D	E	F	Wt. (lb.)
520510AX	3/4" nptf	3/4" nptm	7 7/8"	4 1/4"	5 5/8"	2 1/4"	2.9
520516AX	3/4" nptf	3/4" press	8"	4 9/16"	5 7/8"	2 9/16"	2.9
520519AX	3/4" nptf	3/4" swt	7 3/4"	4 9/16"	5 1/2"	2 9/16"	2.9

Lay length (hot inlet to mix outlet) for press: 5 9/16"; for sweat: 5 9/16".

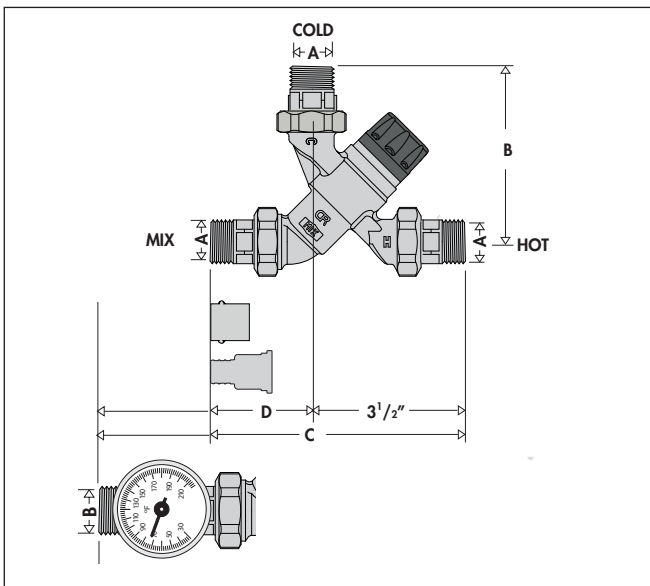

Code	Fitting code	A	B	C	D	Wt. (lb.)
520051A*	NA20650**	3/4" nptm	4"	5 1/4"	2 1/4"	2.8
	NA20653**	3/4" nptf	4 1/4"	5 3/4"	2 1/4"	2.8
	NA20656**	3/4" press	4"	5 3/4"	2 9/16"	2.8
	NA20657**	3/4" PEX barb	4 1/4"	6 1/2"	2 3/4"	2.8
	NA20659**	3/4" sweat	4"	5 1/4"	2 9/16"	2.8

Add 2 1/4 inch to dimension D and C for temperature gauge adapter on mix outlet, code NA10358 (1" union thread with gauge).

*1" male union connection.

**3 required for all ports, weight includes fittings.

Lay length from Hot Inlet to Mix Outlet for 3/4" press and sweat connections: 3 3/4"

Temperature — exposure time

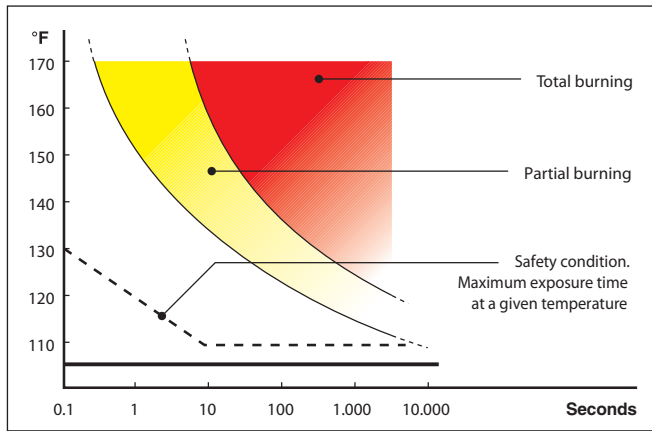

Thermal disinfection

The diagram shows the behavior of the bacteria Legionella Pneumophila when the temperature conditions of the water in which it is contained vary.

In order to ensure proper thermal “disinfection”, the values must not be below 140°F.

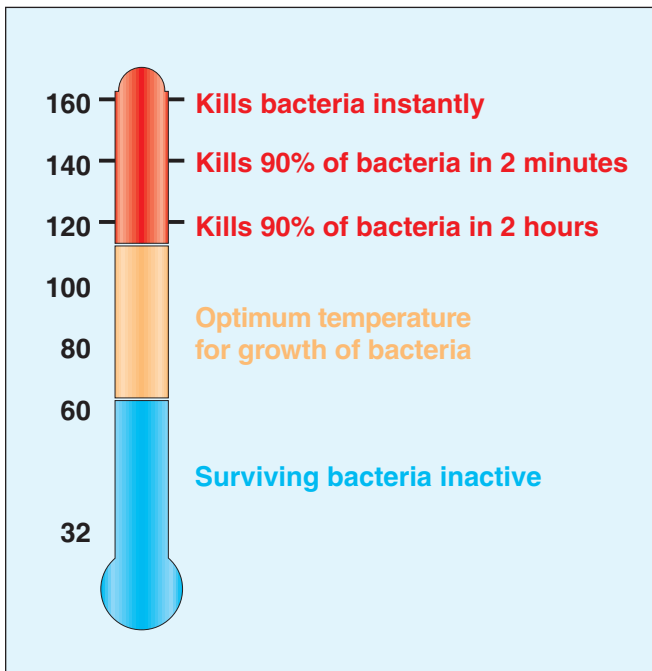

Operating principle

The thermostatic mixing valve mixes the hot and cold water at the inlets to maintain constant mixed water at the desired set temperature. The TankMixer™ 520 series point of distribution mixing valve is an angled configuration combined with a flexible hose and cold water cross for easy installation to most water heaters for direct mounting to the universal ¾” male NPT threaded top pipe connections with a variety of outlet connection styles. This provides increased usable hot water capacity on existing or new high efficiency water heaters by allowing water to be stored at a higher temperature and safely delivered at lower adjustable temperatures to all fixtures. In addition, it can be used to reduce legionella growth by allowing the water heater thermostat to be set at 140°F. The flexible hose length allows mounting to all water heater tank sizes. The TankMixer™ 520_AX series comes standard with a recirculation port that can be plugged or used for connecting to a hot water recirculation loop.

Legionella-scalding risk

In systems producing domestic hot water with storage, in order to avoid the dangerous infection known as Legionella, the hot water must be stored at a temperature of at least 140°F. At this temperature it is certain that the growth of the bacteria causing this infection will be totally eliminated. At this temperature, however, the water cannot be used directly.

As shown on the diagram opposite, temperatures of more than 120°F can cause burning very quickly. For example, at 130°F partial burning will occur in approximately 30 seconds, while at 140°F partial burning will occur in approximately 5 seconds. The time may be reduced by 50 percent or more for children and elderly people.

In view of the above, it is necessary to install a thermostatic mixing valve which can:

- reduce the temperature at the point of use to a value lower than that of storage and suitable for sanitary users. For safety reasons, it is advisable to limit the mixed water temperature to 120°F when point-of-use anti-scalding thermostatic mixing valves are not present at all fixtures.
- maintain the temperature constant when the incoming pressure and temperature conditions vary.

Construction details

Anti-scale materials

The material used in the construction of the Caleffi TankMixer™ 520 series thermostatic mixing valve reduces jamming caused by lime deposits. All the working parts such as shutter, seats and slide guides are made of a special anti-scale polymer material, with a low friction coefficient, assuring long term performance.

Temperature setting and locking

The control knob permits temperature setting between minimum and maximum in one turn (360°). It also has a tamper-proof system to lock the temperature at the set value.

Thermal shut-off

In the event of accidental cold water supply failure, the shutter seals off the hot water passage, thus preventing the delivery of mixed temperature water. This is only guaranteed when there is a minimum temperature difference between the inlet hot water and the mixed temperature water delivery of 27°F. Additionally, the tight closing hot inlet port prevents temperature creep in recirculation applications.

Check valve

In systems with thermostatic mixing valves, check valves must be installed to prevent undesired backflow. The TankMixer™ 520_AX series mixing valves are supplied complete with a check valve (A) on the cold water cross outlet port to the mixing valve.

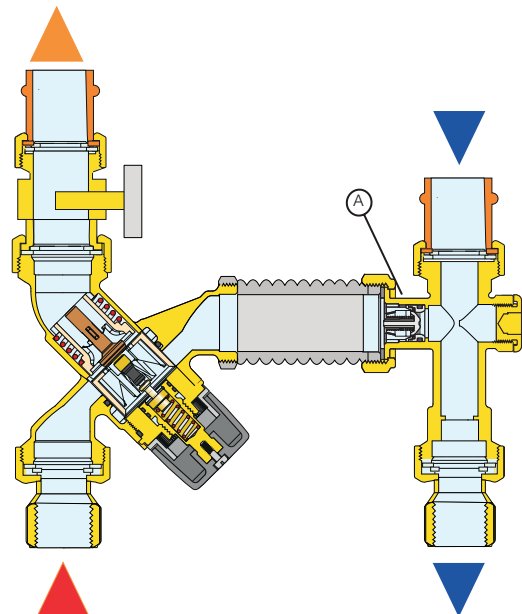

Body shape

The angle body configuration has improved fluid dynamics for better performance, and reduces installation labor and materials because the hot inlet port is in line with the mixed outlet port, eliminating a piping elbow as required for standard mixing valves. The cold inlet comes in from the side.

Hydraulic Characteristics

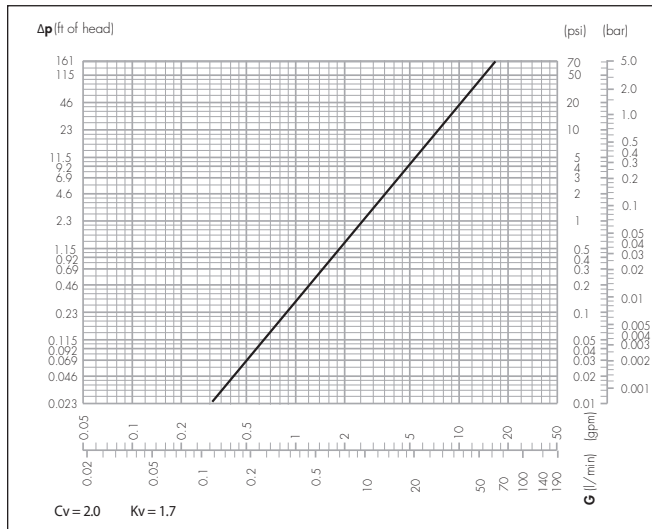

Use

Caleffi TankMixer™ 520 series thermostatic mixing valves are designed to be installed at the hot water heater. The 520 series valve cannot be used for tempering water temperature at fixtures as a point-of-use valve. They are not designed to provide scald protection or chill protection service. They should not be used where ASSE 1070 devices are required. Wherever a scald protection feature is required, Caleffi 5213 series high performance mixing valves need to be installed. For safety reasons, it is advisable to limit the maximum mixed water temperature to 120°F when anti-scald devices are not used at each fixture.

Water heater

As a result of the NAECA, many water heaters now have more insulation making them physically larger, for the same water capacity, than the older models. So units with less capacity are installed requiring higher temperature settings to provide the capacity users were previously accustomed, requiring mixing valves to temper the water to safe levels.

Caleffi TankMixer™ 520_AX series thermostatic mixing valves with cold water cross with check valve assembly and large ID flexible connector will conveniently fit a typical gas-fired water heater and a wide variety of other water heaters. A recirculation return can be connected at the side port of the cold water cross.

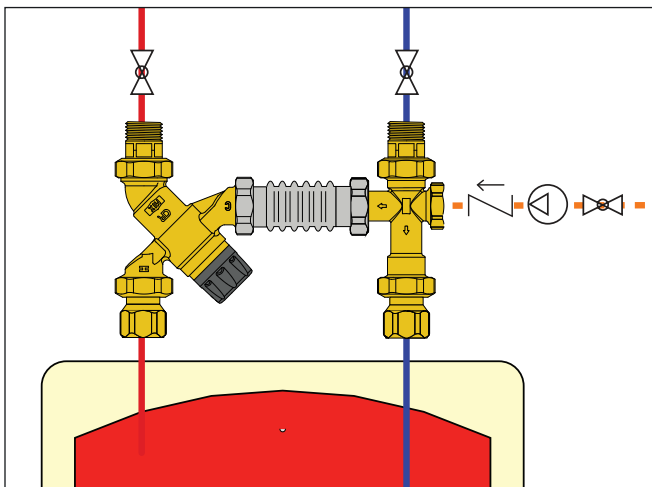

Installation

Before installing a Caleffi TankMixer™ 520 series three-way thermostatic mixing valve, the system must be inspected to ensure that its operating conditions are within the range of the mixing valve, checking, for example, the supply temperature, supply pressure, etc.

Systems where the 520 series thermostatic mixing valve will be installed must be drained and cleaned out to remove any dirt or debris which may have accumulated during installation.

The installation of appropriately sized filters at the inlet from the main water supply is always advisable.

Caleffi TankMixer™ 520 series thermostatic mixing valves must be installed by qualified personnel in accordance with the diagrams in this brochure, taking into account all current applicable standards.

Caleffi TankMixer™ 520 series thermostatic mixing valves can be installed in any position, either vertical or horizontal, or upside down.

The following are shown on the thermostatic mixing valve body:

- Hot water inlet, color red and marked "HOT".
- Cold water inlet, color blue and marked "COLD".
- Mixed water outlet, marked "MIX".

The TankMixer™ 520_AX series comes packaged in a kit with everything needed for fast installation including union fittings and press connections.

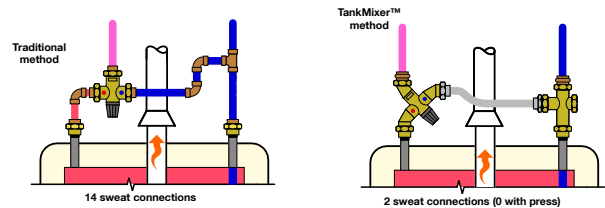

Commissioning

The Caleffi TankMixer™ 520 series thermostatic mixing valve must be commissioned in accordance with current standards by qualified personnel using temperature measuring equipment. Caleffi 520510AX, 520516AX and 5210519AX with integral outlet port temperature gauge provide a time-saving temperature setting process to get close to the desired temperature. Use of a digital thermometer is recommended for confirming the final setting of the mixed water temperature. Note: For models purchased without the outlet temperature gauge, the temperature gauge adapter with temperature gauge can be separately purchased and field installed, code NA10056 for 3/4" models.

Temperature adjustment

The temperature is set to the required value by means of the knob with the graduated scale, on the top of the valve.

Pos.	Min.	1	2	3	4	5	6	7	Max.
T (°F)	95	105	115	120	125	132	140	145	150
T (°C)	35	40	45	48	52	56	60	63	65

with: $T_{HOT} = 158^{\circ}F (70^{\circ}C)$, with: $T_{cold} = 59^{\circ}F (15^{\circ}C)$, $P = 43 \text{ psi (3 bar)}$

Locking the setting

Position the handle to the number required with respect to the index point. Unscrew the head screw, pull off the handle and reposition it so that the handle fits into the internal slot of the knob. Tighten the head screw.

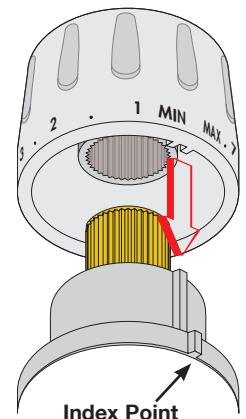

Replacement parts



Replacement body.
Meets requirements of NSF/ANSI 372-2011. Certified to: ASSE 1017/CSA B125.3, Low lead, by ICC-ES file PMG-1360.
End connection flexibility: 1/2", 3/4" or 1" npt female or male, press, PEX barb or sweat with or without check valves, separately sourced for field installation. See Caleffi List Price catalog for fitting selection.



520015A.....1" male union thread, Cv=2.0 (Kv=1.7)









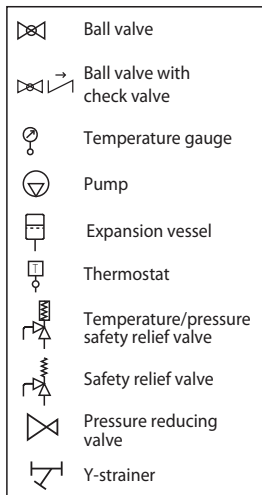
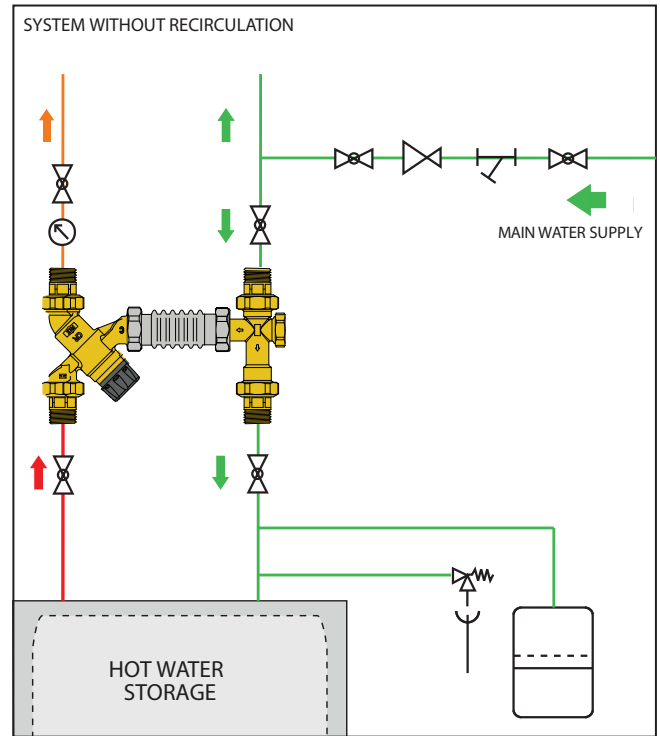
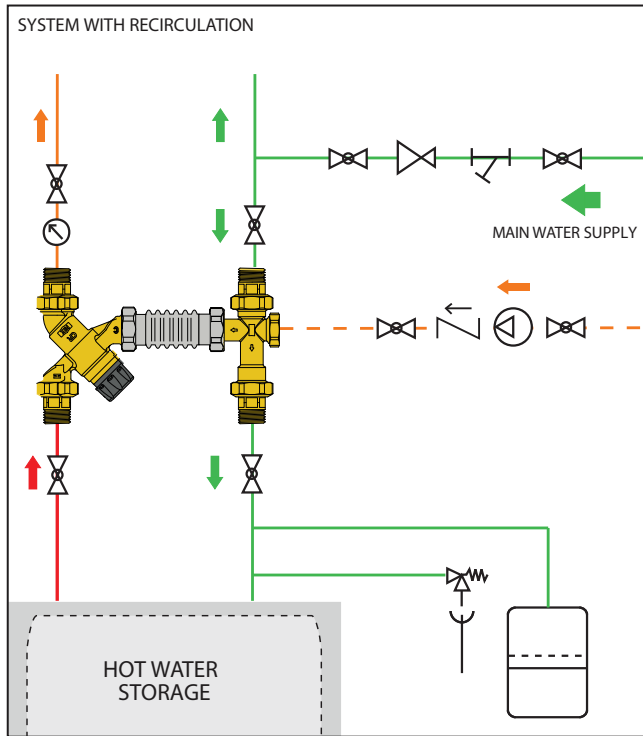



Point of distribution mixed temperature gauge adaptor fits TankMixer™ 520 series mixing valves. Threaded union mounting replaces existing mixed outlet with 3/4" or 1" sweat pipe connection. Removable gauge fits into temperature well. Gauge dial is 2" diameter and scale from 30–210° F.
Low-lead brass body.

NA10056.....3/4" sweat with gauge
NA103581" union thread with gauge
688003A.....Replacement gauge

Application diagrams



Application diagrams

-  Ball valve
-  Ball valve with check valve
-  Temperature gauge
-  Pump
-  Expansion vessel
-  Thermostat
-  Temperature/pressure safety relief valve
-  Safety relief valve
-  Pressure reducing valve
-  Y-strainer

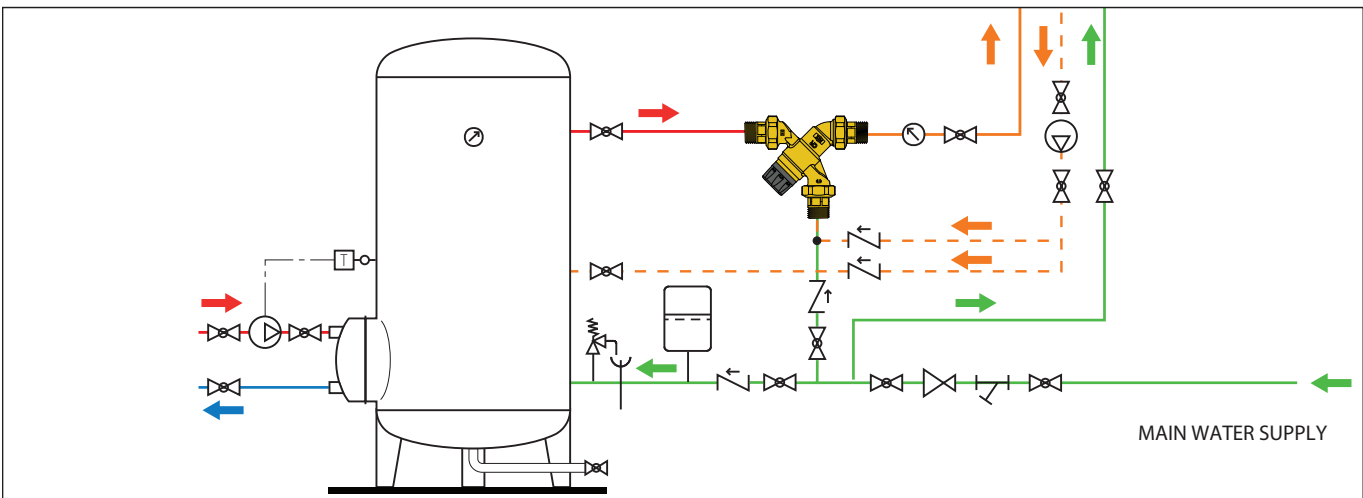
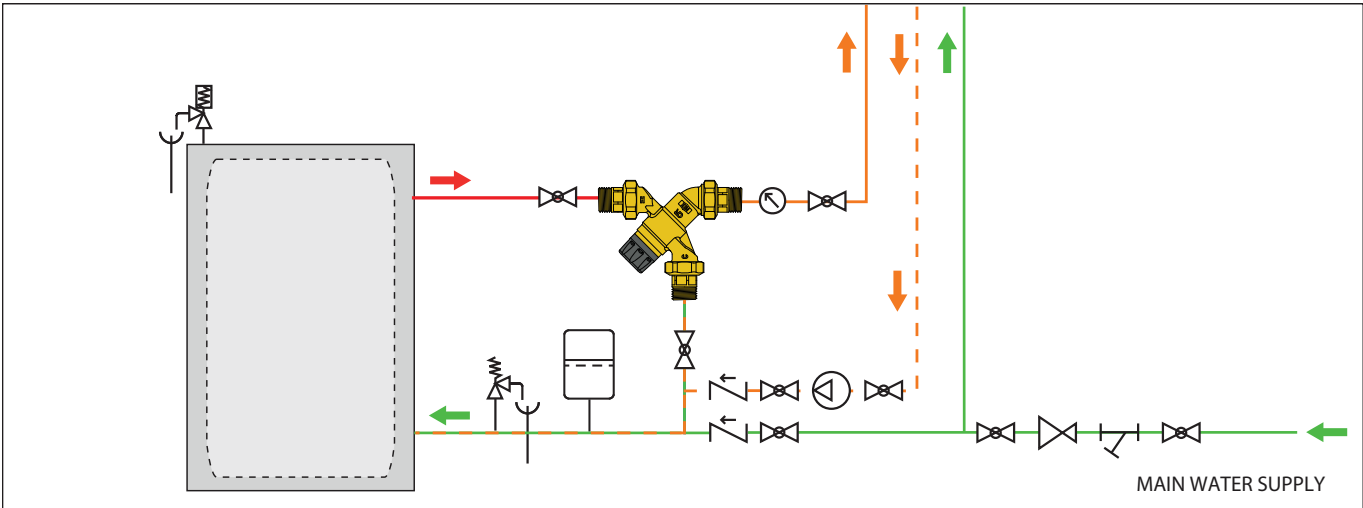
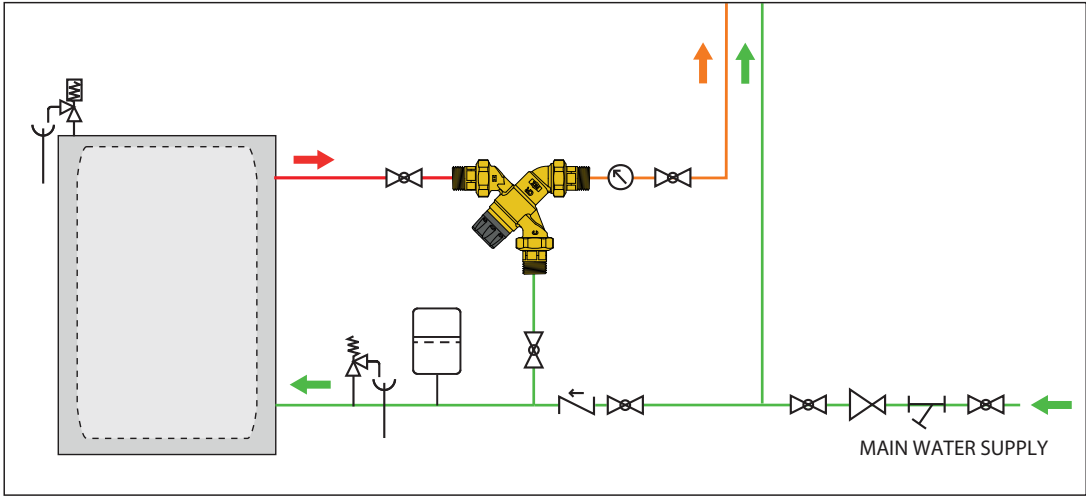

SPECIFICATION SUMMARIES

TankMixer™ 5205_AX series - thermostatic mixing valve with flexible pipe and cold water cross

Adjustable thermostatic and pressure balanced mixing valve, certified by ICC-ES to ASSE 1017-2009 and CSA B125.3, approved for point of distribution domestic water systems. Connections ¾" NPT male, ¾" sweat or ¾" press with union tailpieces. DZR low-lead brass valve body and cold water cross (<0.25% Lead content) certified by ICC-ES file 1360. Meets requirements of NSF/ANSI 372-2011. Shutter, regulating seats and sliding surfaces in anti-scale plastic, PSU. Seals EPDM. Stainless steel spring. Large ID stainless steel flexible pipe, 18" length. Maximum working temperature 195 degrees F (90 degrees C). Setting range 95 degrees F to 150 degrees F (35 degrees C to 65 degrees C). Maximum working pressure 150 psi (10 bar). Maximum operating differential pressure 75 psi (5 bar). Tolerance ±3 degrees F (±2 degrees C). Flow rating: Cv 2.0 (Kv 1.7). Provided with tamper-proof setting lock. Provided with cold water port check valve in cold water cross outlet. Provide with optional mixed outlet temperature gauge, 30 to 210 degrees F scale, 2 inch diameter. Provided with recirculation return port, ½" NPT female, low-lead brass plug included.

TankMixer™ 520051A - angle style thermostatic mixing valve

Adjustable thermostatic and pressure balanced angle style mixing valve, certified by ICC-ES to ASSE 1017-2009 and CSA B125.3, approved for point of distribution domestic water systems. Connections 1" male union. DZR low-lead brass valve body (<0.25% Lead content) certified by ICC-ES file 1360. Meets requirements of NSF/ANSI 372-2011. Shutter, regulating seats and sliding surfaces in anti-scale plastic, PSU. Seals EPDM. Stainless steel spring. Maximum working temperature 195 degrees F (90 degrees C). Setting range 95 degrees F to 150 degrees F (35 degrees C to 65 degrees C). Maximum working pressure 150 psi (10 bar). Maximum operating differential pressure 75 psi (5 bar). Tolerance ±3 degrees F (±2 degrees C). Flow rating: Cv 2.0 (Kv 1.7). Provided with tamper-proof setting lock. Provide with separately supplied mixed outlet temperature gauge, 30 to 210 degrees F scale, 2 inch diameter. Provide with separately supplied end connection fittings, with or without check valves, for ½", ¾", or 1" NPT male, NPT female, press, PEX barb or sweat with 1" union nut and washer.

We reserve the right to change our products and their relevant technical data, contained in this publication, at any time and without prior notice.



Caleffi North America, Inc.
3883 W. Milwaukee Road
Milwaukee, WI 53208
Tel: 414-238-2360 · Fax: 414-238-2366
sales@caleffi.com · www.caleffi.com
© Copyright 2017 Caleffi North America, Inc.