



2-1/2" DIAL PRESSURE GAUGE LIQUID FILLED - LOWER MOUNT

Application:

General purpose gauge, for potable water pumps & systems, these gauges are suitable for compressors, hydraulic presses, machinery, pneumatic equipment and motors, for most commercial air, water and steam services. To be used with fluid medium which does not clog connection or corrode copper alloy.

Not for use with oxygen, natural gas or propane.

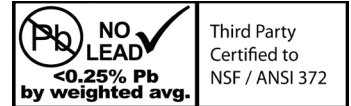

IMPORTANT: Liquid Filled Gauges are sealed with a rubber plug to prevent leaking during shipment. Upon installation the tip of the plug must be cut off in order for the gauge to vent, a small hole allows for equalization of the internal gauge pressure to the atmospheric pressure.

FAILURE TO DO SO WILL ADVERSELY EFFECT THE FUNCTION OF THE GAUGE.

Glycerin Temperature Rating: Gauges are filled with 99.7% concentration glycerin, which starts to become viscous at +63°F (17°C). As the temperature decreases, the more viscous glycerin becomes, which causes the pointer to move slower to its correct position. At 23°F (-5°C) these gauges will no longer operate. For operating temperatures lower than 23°F (-5°C), glycerin should be mixed 2 parts glycerin with 1 part water (66.7% concentration) which lowers the freezing point allowing the gauge to be used in temperatures as low as -51°F (-46°C).

Certification:

- NSF/ANSI Standard 372 Certified (No Lead Series Only)

GAUGE SPECIFICATIONS	
Standard	ASME B40.1
Dial	2-1/2" (63.5mm) white aluminum dial
Case	304 Stainless Steel
Lens	Polycarbonate
Ring (Bezel)	304 Stainless Steel
Connection	Brass / No Lead Brass
Bourdon Tube	Brass
Fill Liquid	Glycerin (99.7% concentration)
Movement	Brass / No Lead Brass
Pointer	Aluminum (Anodized Black)
Welding	Tin Solder (600 PSI & lower)
	Silver Solder (1000 PSI & greater)
Working Pressure	Maximum 75% of Full Scale Value (F.S.V.)
Ambient Op. Temp.	-4°F to 140°F (-20°C to 60°C)
Media Op. Temp.	Max. 140°F (60°C)
Accuracy	+/- 1.5 % F.S.V.
Enclosure Rating	General Purpose
Restrictor Screw - can be used to dampen pulsation surges	
15 - 600 PSI	Tapped but not included
1000 PSI & greater	Tapped and include restrictor screw



25 Whaley Avenue, PO Box 310, Milverton, ON CANADA N0K 1M0
Tel: 519-595-4444 Fax: 519-595-4380 Toll Free: 800-561-3164

www.boshart.com



2-1/2" DIAL PRESSURE GAUGE LIQUID FILLED - LOWER MOUNT

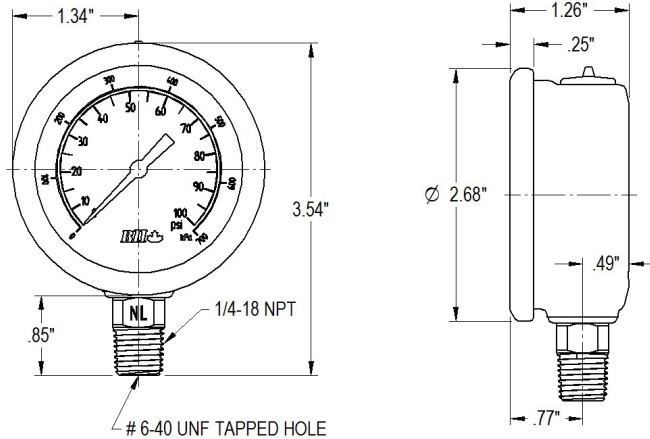

DIMENSIONS

Part No.	No Lead Part No.	Connection	Range		Increments	Weight grams
			PSI	kPa		
2-PG25-15-G	PG25-15-GNL	1/4" MPT	0-15	0-100	0.2	195
2-PG25-30-G	PG25-30-GNL	1/4" MPT	0-30	0-200	0.5	195
2-PG25-60-G	PG25-60-GNL	1/4" MPT	0-60	0-400	1	195
2-PG25-100-G	PG25-100-GNL	1/4" MPT	0-100	0-700	1	195
2-PG25-160-G	PG25-160-GNL	1/4" MPT	0-160	0-1100	2	195
2-PG25-200-G	PG25-200-GNL	1/4" MPT	0-200	0-1400	2	195
2-PG25-300-G	PG25-300-GNL	1/4" MPT	0-300	0-2000	5	195
N/A	PG25-400-GNL	1/4" MPT	0-400	0-2800	5	195
N/A	PG25-600-GNL	1/4" MPT	0-600	0-4000	10	195
2-PG25-1000-G	N/A	1/4" MPT	0-1000	0-7000	10	195
2-PG25-1500-G	N/A	1/4" MPT	0-1500	0-10000	20	195
2-PG25-2000-G	N/A	1/4" MPT	0-2000	0-14000	20	195
2-PG25-3000-G	N/A	1/4" MPT	0-3000	0-20000	50	195
2-PG25-4000-G	N/A	1/4" MPT	0-4000	0-28000	50	195
2-PG25-5000-G	N/A	1/4" MPT	0-5000	0-35000	50	195
2-PG25-10000-G	N/A	1/4" MPT	0-10000	0-70000	100	195
VACUUM GAUGE						
2-PGV25-30-G	N/A	1/4" MPT	30Hg-0		0.5	195
VACUUM / PRESSURE GAUGE						
2-PGC25-30-30-G	N/A	1/4" MPT	30Hg-0-30		2/1	195
2-PGC25-30-150-G	N/A	1/4" MPT	30Hg-0-150		10/5	195



COMMITTED TO EXCELLENCE SINCE 1955

25 Whaley Avenue, PO Box 310, Milverton, ON CANADA N0K 1M0
Tel: 519-595-4444 Fax: 519-595-4380 Toll Free: 800-561-3164

www.boshart.com