



THE FORD METER BOX COMPANY, INC.
CERTIFIED TO ISO 9001:2015
10002505

Section **AB**

07/2016

Web Revision 11/06/2018

Ford Drilling Machines

Parts and Instruction Manual

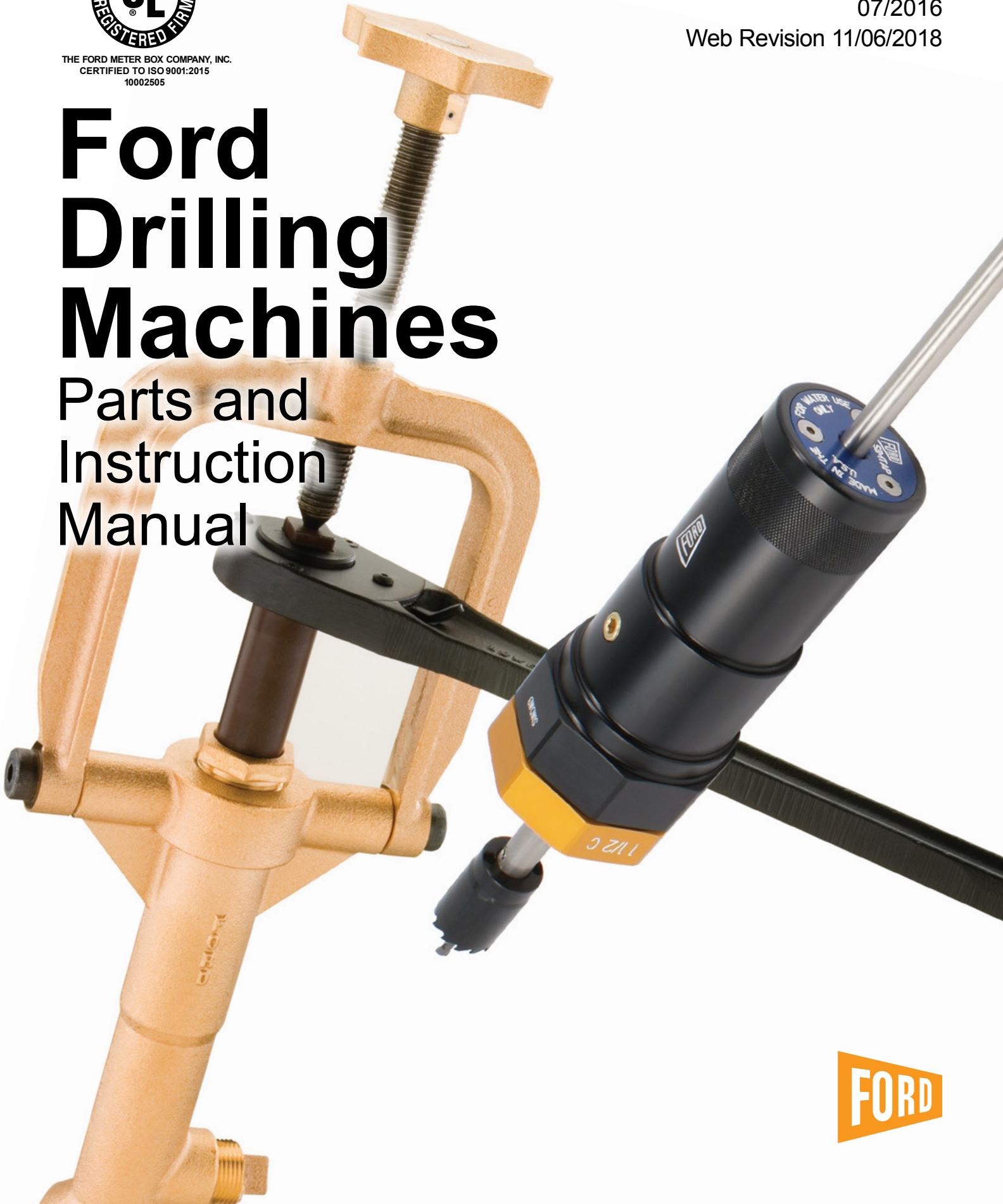

Contents

	Page
Ford Model 77 Drilling Machine Information	
Information and Optional Items	3
Ford Model 77 Drilling Machine Kits	
Drilling Machine Kits and Components	4
Optional Items for 1/2" Through 1-1/4" Drilling Requirements	4
Optional Items for 1-1/4" Through 2" Drilling Requirements	5
Ford Model 77 Drilling Machine Options	
Cutting Tools	6
Adapters	6
Boring Bars	6
Ford Model 77 Operating and Assembly Instructions	7 & 8
Ford SIMTAP™ Drilling Machine Information	
Information and Optional Items	9
Ford SIMTAP™ Drilling Machine Kits	
SIMTAP™ Kits and Components	10
Optional Items	10
Ford SIMTAP™ Drilling Machine Options	
Cutting Tools	11
SIMTAP™ Adapters	11
Ford SIMTAP™ Drilling Machine Operating and Assembly Instructions	12 & 13
Ford Drilling Machine Adapters	
Recommended Drilling Machine Adapters	14
Recommended Drill Sizes	15
Recommended Tapping Machine Adapters	15
Warranty	16

Information

The Ford Model 77 Complete Drilling Machine Kit Includes:

- The Drilling Machine (items 1 through 9A on page AB-4)
- Flare Copper Thread Adapters for 3/4" and 1" Corporation Stops (item 10 on page AB-4)
- Two small adjustable open-end wrenches (item 11 on page AB-4)
- Tool Box (item 12 on page AB-4)

Optional Items

- 1/2" - 1" Drills for Cast Iron and A/C
- 1/2", 3/4" and 1" Shell Cutters for PVC
- 1-1/4" Drills for Ductile Iron or A/C
- 1-1/4", 1-1/2" and 2" Shell Cutters for PVC and A/C
- 1-1/2" and 2" Shell Cutters for Ductile Iron
- 2" Hole Saw for Ductile Iron, PVC and A/C
- Boring Bars for other sizes of Corporation Stops
- Adapters for different sizes and styles of Corporation Stops
- Chip flushing equipment (page AB-4) (see ordering information below)
 1. Substitute flush valve or hose adapter for plug. Attach hose.
 2. When drill or PVC cutter cuts through main, water pressure tends to wash chips through machine and hose.



DMRW Ratchet Wrench – For best results, periodic maintenance is required. The frequency is determined by the degree of exposure to harmful elements, such as sand, dirt, etc. It is recommended to submerge the head of the ratchet in diesel fuel to loosen internal dirt. Liquid applied thread lock should be refreshed occasionally to ensure cover plate screws remain secure.

Ordering Information

Drilling Machine only includes items 1 through 9A on page AB-4.

Complete Drilling Machine Kit includes items 1 through 12 on page AB-4. Drills, shell cutters and hole saws should be ordered separately.

Optional items and spare parts should be ordered separately.

The Ford Model 77 Drilling Machine

DRILLING MACHINE KITS

CATALOG NUMBER	DESCRIPTION
DMO-NL	Model 77 Drilling Machine (items 1 through 8) (10 lb.)
DMO-1-9A-NL	Model 77 Drilling Machine including Boring Bars (items 1 through 9A)
DMK-1-12A-NL	Model 77 Drilling Machine Kit Complete (items 1 through 12) (36 lb.)

Drills, cutters and hole saws are not included with kits. See page AB-6 for a complete list of these items.

DRILLING MACHINE COMPONENTS

REF. No.	DESCRIPTION	CATALOG NUMBER
1	Handwheel and Feedscrew	DMHF
2	Ratchet Wrench	DMRW
3	Yoke	DMY
4	Yoke Bolts (2)	DMYB
5	Plug - 3/4" Iron Pipe Thread	DMP-3-NL
6	Packing Bushing	DMPB-NL
7	Boring Bar Packing (2)	DMBBP
8	Body	DMB-NL
9	Boring Bar Only (fits 11/16" drill and shell cutter for 3/4" corp stop)	DMBB-3-SS-NL
9A	Boring Bar Only (fits 7/8" drill and shell cutter for 1" corp stop)	DMBB-4A-SS-NL
10	3/4" Flare Copper Adapter with Gaskets	DMA2-3-NL
	1" Flare Copper Adapter with Gaskets	DMA2-4-NL
11	Open-end Adjustable Wrenches (2) 1 each of 8" and 10"	DMAW-PR
12	Tool Box	DMTB

OPTIONAL ITEMS

-	Drilling Machine Ratchet Wrench Repair Kit	DMRWRK
13	Hose Adapter for Chip Flushing	DMHA-NL
14	Ball Valve with Hose threads for Chip Flushing	B8H-233-HB-2-NL
15	10 ft. Hose for Chip Flushing	DMH-10
16	Outside Gasket for all Corp Stop Adapters	GT-130

OPTIONS FOR 1/2" - 1-1/4" DRILLING REQUIREMENTS

17	7/16" Drill for 1/2" Corp Stop (fits boring bar DMBB-1-NL)	DMD-1-NL
	9/16" Drill for 5/8" Corp Stop (fits boring bar DMBB-2-NL)	DMD-2-NL
	11/16" Drill for 3/4" Corp Stop (fits boring bar DMBB-3-SS-NL)	DMD-3-NL
	7/8" Drill for 1" Corp Stop (fits boring bar DMBB-4A-SS-NL)	DMD-4A-NL
18	Boring Bar for 7/16" Drill for 1/2" Corp Stop	DMBB-1-NL
	Boring Bar for 9/16" Drill for 5/8" Corp Stop	DMBB-2-NL
20	7/16" Shell Cutter for PVC (fits boring bar DMBB-1-NL)	DMSC-1-NL
	11/16" Shell Cutter for PVC (fits boring bar DMBB-3-SS-NL)	DMSC-3-NL
	7/8" Shell Cutter for PVC (fits boring bar DMBB-4A-SS-NL)	DMSC-4A-NL
	1/2" Flare Copper Adapter with Gaskets	DMA2-1-NL
21	5/8" Flare Copper Adapter with Gaskets	DMA2-2-NL
	1-1/4" Flare Copper Adapter with Gaskets	*DMA2-5-NL
	3/4" Female Iron Pipe Adapter with Gaskets	DMA1-3-NL
	1" Female Iron Pipe Adapter with Gaskets	DMA1-4-NL
	1-1/4" Female Iron Pipe Adapter with Gaskets	*DMA1-5-NL
	1-1/4" Quick Joint Adapter with Gaskets (CTS)	*DMA4-5-Q-NL
22	3/4" Quick Joint Adapter with Gaskets (PEP)	DMA6-3-Q-NL
	1" Quick Joint Adapter with Gaskets (PEP)	DMA6-4-Q-NL
	Inside Gasket for 1/2" Flare Copper Adapter	GT-106
	Inside Gasket for 5/8" Flare Copper Adapter	GT-107
	Inside Gasket for 3/4" Flare Copper Adapter	GT-118
	Inside Gasket for 1" Flare Copper Adapter	GT-119
	Inside Gasket for 1-1/4" Flare Copper Adapter	GT-147
	Inside Gasket for 3/4" Iron Pipe Adapter	GT-114
	Inside Gasket for 1" Iron Pipe Adapter	GT-120
	Inside Gasket for 1-1/4" Iron Pipe Adapter	GT-119

Note: 1-1/4", 1-1/2" and 2" equipment on following page.

* For use with 7/8" (1" nominal) drill or shell cutter and DMBB-4A-SS-NL boring bar. See following page for 1-1/8" cutters and adapters.

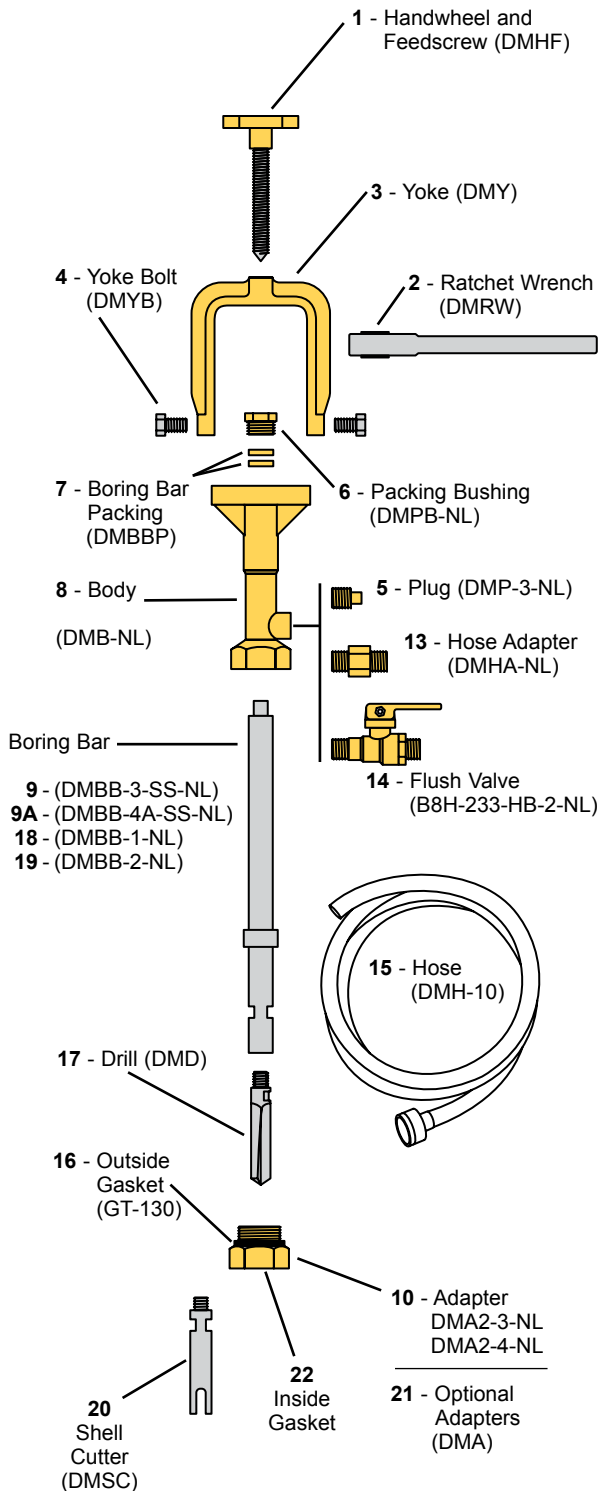

The Ford Model 77 Drilling Machine

Optional Items for 1-1/4", 1-1/2" and 2" Drilling Requirements

The Ford Drilling Machine, with its lightweight design and size, is ideal for making taps up to 1". The Ford Drilling Machine can be adapted for 1-1/4", 1-1/2" and 2" taps. The following items will allow for **occasional** taps for 1-1/4", 1-1/2" and 2". Please note the Ford Drilling Machine is not recommended for making routine taps larger than 1".

Optional Items for 1-1/4", 1-1/2" and 2" Drilling Requirements

CATALOG NUMBER	DESCRIPTION
ADAPTERS	
DMA1-5-NL	1-1/4" Adapter with 1-1/4" FIP threads for use with FB800-5-NL and FB900-5-NL Corp Stops
*DMA1-5F-SS-NL	1-1/4" Adapter with 1-1/4" FIP threads for use with FB400-5-NL and FB500-5-NL Corp Stops
DMA1-6-NL	1-1/2" FIP Adapter with gaskets for use with FB400-6-NL and FB500-6-NL
*DMA2-5F-SS-NL	1-1/4" Adapter with 1-1/4" Flare Copper threads for use with FB600-5-NL and FB700-5-NL Corp Stops
DMA2-6-NL	1-1/2" Flare Copper Adapter with gaskets for use with FB600-6-NL and FB700-6-NL
*DMA2-6F-NL	1-1/4" Adapter with 1-1/2" Flare Copper threads for use with FB1001-5-NL and FB1101-5-NL Corp Stops
*DMA4-5F-Q-SS-NL	1-1/4" Quick Joint Adapter with gaskets
DMA4-6-Q-NL	1-1/2" CTS Quick Joint Adapter with gaskets
DMA1-67-NL	1-1/2" Adapter with 2" FIP threads for use with 1-1/2" FB800-NL and FB900-NL Corp Stops
DMA1-7-NL	2" FIP Adapter with gaskets for use with FB400-7-NL and FB500-7-NL
DMA2-7-NL	2" Flare Copper Adapter with gaskets for use with FB600-7-NL and FB700-7-NL
DMA4-7-Q-NL	2" CTS Quick Joint Adapter with gaskets
DMA1-78-NL	2" Adapter with 2-1/2" FIP threads for use with 2" FB800-NL and FB900-NL Corp Stops
DMA8-6-SS-NL	1-1/2" Adapter with 1-1/2" MIP threads for use with 1-1/2" FB1600-NL and FB1700-NL Corp Stops
DMA8-6-BSPT-SS-NL	1-1/2" Adapter with 1-1/2" MIP BSPT threads
DMA8-7-SS-NL	2" Adapter with 2" MIP threads for use with 2" FB1600-NL and FB1700-NL Corp Stops
DMA8-7-BSPT-SS-NL	2" Adapter with 2" MIP BSPT threads
DRILLS	
DMD-5-DI-NL	1-1/8" Drill for 1-1/4" Corp Stop (fits boring bar DMBB-67-SS-NL)
HOLE SAWS	
DMHS-7-NL	1-7/8" Hole Saw for 2" Corp Stop (fits Arbor DMA-67-NL)
DMHSS	Package of 6 Hole Saw Spacers
DMA-67-NL	Arbor only for use with Boring Bar DMBB-67-SS-NL (includes DMPD-NL pilot drill and DMHSS Spacer)
SHELL CUTTERS	
DMSC-5-PVC-NL	1-1/8" Shell Cutter for 1-1/4" Corp Stop (fits boring bar DMBB-67-SS-NL)
DMSC-6-DI-NL	1-3/8" Shell Cutter for Ductile Iron Pipe, 1-1/2" Corp Stop (fits boring bar DMBB-67-SS-NL) (includes DMPD pilot drill)
DMSC-6-PVC-NL	1-3/8" Shell Cutter for PVC Pipe, 1-1/2" Corp Stop (fits boring bar DMBB-67-SS-NL)
DMSC-7-DI-NL	1-7/8" Shell Cutter for Ductile Iron Pipe, 2" Corp Stop (fits boring bar DMBB-67-SS-NL) (includes DMPD pilot drill)
DMSC-7-PVC-NL	1-7/8" Shell Cutter for PVC Pipe, 2" Corp Stop (fits boring bar DMBB-67-SS-NL)
BORING BAR AND PILOT DRILL	
DMBB-67-SS-NL	Boring Bar for 1-1/4", 1-1/2" and 2" Corp Stops
DMPD-NL	1/4" Pilot Drill for use with DMSC-6-DI-NL, DMSC-7-DI-NL or DMA-67-NL Arbor
ADAPTER GASKETS	
GT-119	Inside Gasket for DMA6-3-Q-NL Adapter
GT-128	Inside Gasket for DMA6-4-Q-NL Adapter
GT-126	Inside Gasket for DMA4-6-Q-NL Adapter
GT-127	Inside Gasket for DMA4-7-Q-NL Adapter
GT-143	Inside Gasket for DMA2-6-NL and DMA1-67-NL Adapters
GT-142	Inside Gasket for DMA1-6-NL Adapter
GT-144	Inside Gasket for DMA1-7-NL Adapter
GT-132	Inside Gasket for DMA2-7-NL and DMA1-78-NL Adapters

* To be used only with DMBB-67-SS-NL boring bar, DMD-5-DI-NL drill and DMSC-5-PVC-NL cutter.

Note: 1-7/8" DMHS hole saws **require** a DMA-67-NL arbor.

1-1/8", 1-3/8" and 1-7/8" DMSC shell cutters ATTACH to the DMBB-67-SS-NL boring bar and will not fit a DMA-67-NL arbor.

Example of a DMA-67-NL 2" Arbor Assembly (for Hole Saw only)

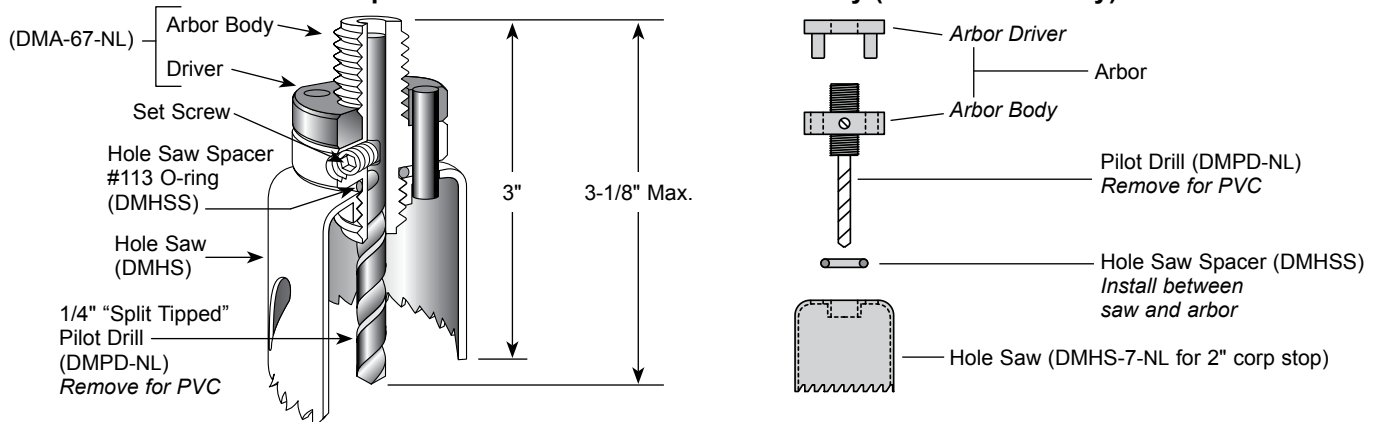

Note: All cutters and drills are perishable tools which begin to wear upon initial use. Sharpness and operator handling are critical to the tool's proper performance.

The Ford Model 77 Drilling Machine

Option Selection Charts: Cutting Tools, Adapters and Boring Bars

CUTTING TOOLS: To select a cutting tool, choose the proper column for type of water main and select the nominal hole size.

Cutting Tools

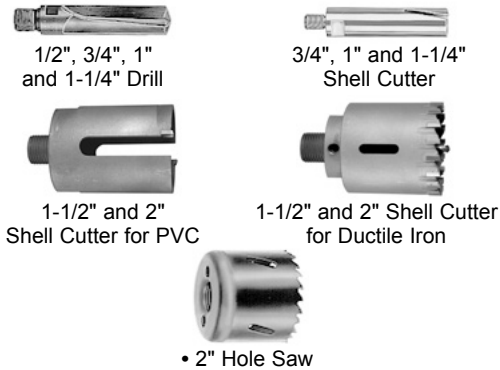

CATALOG NUMBER	DESCRIPTION	ACTUAL CUTTER DIAMETER	TYPE OF WATER MAIN (NOMINAL HOLE SIZE)		
			PVC	IRON	ASBESTOS CEMENT
DMD-1	Drill	7/16"	-	1/2"	1/2"
DMD-2	Drill	9/16"	-	5/8"	5/8"
DMD-3	Drill	11/16"	-	3/4"	3/4"
DMD-4A	Drill	7/8"	-	1"	1"
DMD-5-DI	Drill	1-1/8"	-	1-1/4"	1-1/4"
DMSC-1	Shell Cutter	7/16"	1/2"	-	-
DMSC-3	Shell Cutter	11/16"	3/4"	-	-
DMSC-4A	Shell Cutter	7/8"	1"	-	-
DMSC-5-PVC	Shell Cutter	1-1/8"	1-1/4"	-	1-1/4"
DMSC-6-DI	Shell Cutter	1-3/8"	-	1-1/2"	-
DMSC-6-PVC	Shell Cutter	1-3/8"	1-1/2"	-	1-1/2"
DMSC-7-DI	Shell Cutter	1-7/8"	-	2"	-
DMSC-7-PVC	Shell Cutter	1-7/8"	2"	-	2"
DMHS-7	Hole Saw	1-7/8"	2"	2"	2"

• Requires DMA-67 Drilling Machine Adapter

ADAPTERS: To select an adapter, choose the proper column for corporation body outlet thread type (see page AB-14 to determine a corporation body outlet thread type and size) and select the desired thread size.

Drilling Machine Adapters



CATALOG NUMBER	FLARE COPPER THREAD	CORPORATION BODY OUTLET THREAD TYPE (NOMINAL THREAD SIZE)			INSIDE GASKET OR O-RING
		MALE IRON PIPE THREADS	SPECIAL QUICK JOINT THREAD	FEMALE IRON PIPE THREAD	
DMA2-1-NL	1/2"				GT-106
DMA2-2-NL	5/8"				GT-107
** DMA2-3-NL	3/4"				GT-118
** DMA2-4-NL	1"				GT-119
+ DMA2-5-NL	1-1/4"				GT-147
* DMA2-5F-SS-NL	1-1/4"				GT-147
DMA2-6-NL	1-1/2"				GT-143
* DMA2-6F-NL	1-1/2"				GT-143
DMA2-7-NL	2"				GT-132
DMA1-3-NL		3/4"			GT-114
DMA1-4-NL		1"			GT-120
+ DMA1-5-NL		1-1/4" (FB800-5 and FB900-5)			GT-119
* DMA1-5F-SS-NL		1-1/4" (FB400-5 and FB500-5)			ORING-650220-EP
DMA1-6-NL		1-1/2"			GT-142
DMA1-67-NL		2" (FB800-6 and FB900-6)			GT-143
DMA1-7-NL		2"			GT-144
DMA1-78-NL		2-1/2" (FB800-7 and FB900-7)			GT-132
+ DMA4-5-Q-NL			1-1/4" CTS Quick Joint		GT-128
* DMA4-5F-Q-SS-NL			1-1/4" CTS Quick Joint		GT-262
DMA4-6-Q-NL			1-1/2" CTS Quick Joint		GT-126
DMA4-7-Q-NL			2" CTS Quick Joint		GT-127
DMA6-3-Q-NL			3/4" PEP Quick Joint		GT-119
DMA6-4-Q-NL			1" PEP Quick Joint		GT-128
DMA8-6-SS-NL				1-1/2" (1-1/2" FB1600/1700 Ballcorps)	ORING-650223-BN
DMA8-7-SS-NL				2" (2" FB1600/1700 Ballcorps)	ORING-650227-BN

* To be used only with DMBB-67-SS-NL boring bar, DMD-5-DI-NL drill and DMSC-5-PVC-NL cutter.

** This item is included in the complete Drilling Machine Kit, catalog number DMK-1-12A-NL.

+ For use with 7/8" (1" nominal) drill or shell cutter and DMBB-4A-SS-NL.

◆ Outside gasket for all adapters is GT-130.

BORING BARS: Select the boring bar that corresponds to the cutting tool(s) that meets your drilling requirements.

Boring Bars



CATALOG NUMBER	CORRESPONDING CUTTING TOOLS
DMBB-1-NL	DMD-1-NL, DMSC-1-NL
DMBB-2-NL	DMD-2-NL
▲** DMBB-3-SS-NL	DMD-3-NL, DMSC-3-NL,
▲** DMBB-4A-SS-NL	DMD-4A-NL, DMSC-4A-NL
DMBB-67-SS-NL	DMSC-6-DI-NL, DMSC-6-PVC-NL, DMSC-7-DI-NL, DMSC-7-PVC-NL, DMD-5-DI-NL, DMSC-5-PVC-NL
DMBB-67-SS-NL	DMHS-7-NL
* DMA-67-NL	DMHS-7-NL

Notes: * DMA-67-NL (Drilling Machine Arbor) is required for 2" hole saw, DMHS-7-NL.

** This item is included in the complete Drilling Machine Kit, catalog number DMK-1-12A-NL.

▲ This item is included in the Drilling Machine only, catalog number DMO-1-9A-NL.

Model 77 Operating Instructions

CAUTION: Always follow pipe manufacturer's recommendations to protect from injury.

1. Remove the Drilling Machine from the Tool Box (DMTB) and lay it on a flat surface. Back the Feedscrew (DMHF) out until the end is flush with the Yoke Assembly (DMY).



2. Select the diameter of Boring Bar (DMBB) which will pass through the Corporation Stop when it is open. Attach the Drill (DMD) to the Boring Bar (DMBB) and lightly tighten with the adjustable wrenches.



3. Insert the Boring Bar (DMBB) into the body of the machine until the shoulder hits the stop. Gently tighten the Packing Bushing (DMPB).



4. Select the Adapter (DMA) that matches the outlet threads on the Corporation Stop. Attach the Adapter (DMA) to the bottom of the Drilling Machine.



5. Mount the pipe saddle and Corporation Stop on the water main and tighten the saddle straps. Mount the Drilling Machine onto the Corporation Stop. **Check to be sure the Corporation Stop is fully open.**



6. Carefully lower the Drill (DMD) until it touches the water main. Attach the Ratchet (DMRW) to the top of the Boring Bar (DMBB). Raise the Yoke (DMY) until the Feedscrew (DMHF) is centered over the Boring Bar (DMBB). Place a few drops of oil on the point of the Feedscrew (DMHF) and mate the point with the center of the Boring Bar (DMBB). Open Chip Flushing Port (if equipped).

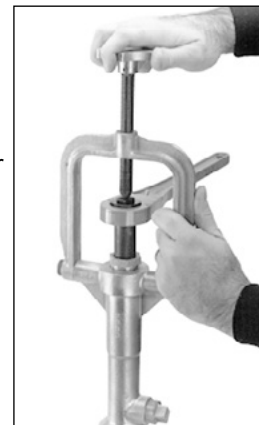

7. Rotate the Ratchet (DMRW) clockwise **only** while applying a **light** turn of the Feedscrew (DMHF). Make at least two (2) quarter turns of the Ratchet (DMRW) before applying more pressure on the Feedscrew (DMHF). Use Feedscrew (DMHF) as follower only and exert light pressure on the Boring Bar (DMBB). When drilling PVC pipe, use a steady continuous cutting action and do **not** stop until the cutter is completely through the pipe. With PVC it is important to continue cutting until the Shell Cutter has penetrated the wall of the water main and the Boring Bar (DMBB) shoulder contacts the bottom stop in the Adapter (DMA).



8. Slowly reverse the Feedscrew (DMHF) and allow the Boring Bar (DMBB) to slowly back out until it hits the top stop in the machine. If you are drilling into a live/pressurized line, the Drilling Machine will be under pressure. As you back out the Boring Bar, place the palm of your hand on the Ratchet to prevent the Boring Bar from snapping out of the main. Close the Corporation Stop and release the entrapped pressure before removing the Drilling Machine from the Corporation Stop.



IMPORTANT – GENERAL MAINTENANCE

1. Clean the tools and lightly oil the boring bar (DMBB) and cutters before returning them to the tool box (DMTB).
2. When using the PVC shell cutter (DMSC), the assembly and operation is the same as using a drill (DMD). For 3/4" PVC taps, use the 11/16" shell cutter (DMSC-3-NL). For 1" PVC taps, use the 7/8" shell cutter (DMSC-4A-NL).
3. Check the cutters regularly for sharpness. Sharp cutters will ensure an easy tap. Professional sharpening is a good investment because the cutting edge will have the proper angle, lip clearance and chisel point to match the hardness of the pipe.
4. When the day's work is completed, always dismantle and replace the drilling machine in the tool box so nothing will be lost or damaged. **Cutters will break easily if the machine assembly is dropped or mishandled.** Simple preventative maintenance will make this device last for many years at a minimal cost per tap.

Ford Model 77 Assembly Instructions for 1-1/4", 1-1/2" and 2" Shell Cutters

For Drilling Cast Iron, Ductile, PVC and A/C Pipe

1. Insert the Boring Bar (DMBB-67-SS-NL) into the Drilling Machine (Fig. 1).
2. Select the Adapter (DMA) that matches the outlet threads of the Corporation Stop and attach it to the bottom of the Drilling Machine (Fig. 2).
3. Follow the drilling procedure as outlined on page AB-7. **When a Shell Cutter is cutting into the pipe, NEVER reverse the direction of rotation or the carbide teeth will be destroyed. ALWAYS TURN CLOCKWISE.**

When making dry taps on Cast Iron, Ductile or A/C pipe, the 1/4" "Split Tipped" Pilot Drill should be used for coupon retention.

Fig. 1

Insert the Boring Bar into the Drilling Machine.



Fig. 2

Select the proper Drilling Machine Adapter and attach it to the Drilling Machine.



Fig. 3

Attach the Shell Cutter to the end of the Boring Bar.

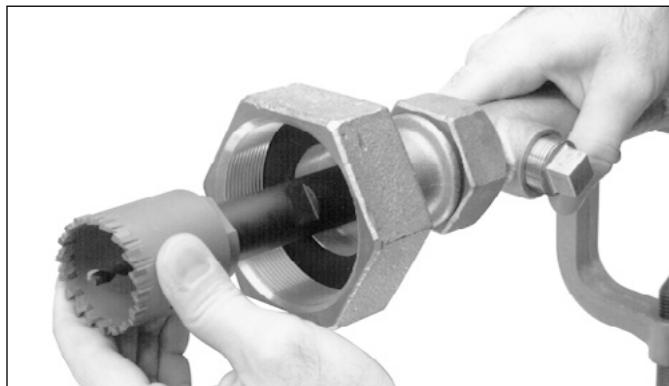

The following is a quotation from the Uni-Bell "Tapping Guide for PVC Pressure Pipe."

PVC is easy to machine, so it is a temptation to overfeed the cutter because it is comparatively easy to turn the ratchet handle. The principle is to allow the cutter to work as a **cutter**. Rotate the ratchet handle one complete turn for every 1/8 turn of the feed yoke (approx. 1" (25mm) movement of feed nut to each 1/4 turn of the ratchet handle).

The feed rate should be reduced in cold weather. Judge the correct feed rate by "finger pull" – the effort should be about the same as that used to open a desk drawer. This rule of thumb applies in any temperature.

The Ford SIMTAP™ Drilling Machine

Information



The Ford SIMTAP™ Complete Drilling Machine Kit Includes:

- The Drilling Machine (items 1 through 11 on page AB-10)
- Adapters for 3/4" through 2" Corporation Stops (item 11 on page AB-10)
- Pneumatic Drill
- Stainless Steel Shaft
- Coupon Retaining Pilot Bit
- Two Coupon Extractors
- Set of four Hole Saws
- Carrying Case

Kits also available in custom configurations

Note: SIMTAP™ can also be powered with a high quality 1/2" battery powered 20v drill.



Ordering Information

The Ford SIMTAP™ Drilling Machine complete kit includes items 1 through 11 on page AB-10.

Optional items and spare parts should be ordered separately, see pages AB-10 and AB-11.

The Ford SIMTAP™ Drilling Machine

SIMTAP™ KITS

CATALOG NUMBER	DESCRIPTION
SIMDMK-NL	Complete SIMTAP™ Drilling Machine with Pneumatic Drill (includes items 1-11) (28.68 lbs)
SIMDMK-LD-NL	The SIMTAP™ Drilling Machine Kit less Pneumatic Drill (includes items 2-11) (25.08 lbs)
SIMDMK-B-NL	The SIMTAP™ Drilling Machine Base Kit (includes items 2-8) (13.4 lbs)

COMPONENT PARTS

REF. No.	CATALOG NUMBER	DESCRIPTION
1	SIMAD	Pneumatic Drill
2	SIMDMB-NL	SIMTAP™ Drilling Machine Body with bleed-off port (combination body and 2" flare copper thread adapter)
3	SIMHW	Pilot Drill Hex Wrench
4	SIMDMBB-SS-NL	Stainless Steel Shaft with Dual Arbor
5	SIMDMAW	Adapter Wrench
6	SIMDMPD-NL	1/4" Coupon Retaining Pilot Bit
7	SIMDMTB	SIMTAP™ Drilling Machine Carrying Case
8	*SIMDRIVE-NL	Drive Ring for use with 1-1/2" and 2" Hole Saws
9	SIMCE1-SS-NL	1/2" Coupon Extractor
	SIMCE2-SS-NL	5/8" Coupon Extractor
10	SIMDMHS-3-NL	11/16" Hole Saw
	SIMDMHS-4-NL	7/8" Hole Saw
	SIMDMHS-6-NL	1-3/8" Hole Saw
	SIMDMHS-7-NL	1-7/8" Hole Saw
11	SIMDMA1-3-NL	3/4" Iron Pipe Thread Adapter (Red)
	SIMDMA2-3-NL	3/4" Flare Copper Thread Adapter (Purple)
	SIMDMA1-4-NL	1" Iron Pipe Thread Adapter (Turquoise)
	SIMDMA2-4-NL	1" Flare Copper Thread Adapter (Grey)
	SIMDMA6-4-Q-NL	1" PEP Quick Joint Thread Adapter (Blue)
	SIMDMA1-6-NL	1-1/2" Iron Pipe Thread Adapter (Brown)
	SIMDMA2-6-NL	1-1/2" Flare Copper Thread Adapter (Orange)
	SIMDMA4-6-Q-NL	1-1/2" CTS Quick Joint Thread Adapter (Green)
	SIMDMA1-7-NL	2" Iron Pipe Thread Adapter (Gold)
	SIMDMA4-7-Q-NL	2" CTS Quick Joint Thread Adapter (Yellow)

* Requires newer model boring bar with flats and dimple/detent.

Optional Items

CATALOG NUMBER	DESCRIPTION
SIMDMA6-3-Q-NL	3/4" PEP Quick Joint Thread Adapter (Aqua)
SIMDMA1-5-NL	1-1/4" Iron Pipe Thread Adapter (Black)
SIMDMA2-5-NL	1-1/4" Flare Copper Thread Adapter (Pink)
SIMDMA4-5-Q-NL	1-1/4" CTS Quick Joint Thread Adapter (Silver)
SIMDMA1-8-NL	2-1/2" Iron Pipe Thread Adapter (Silver)
SIMDMHS-5-NL	1-1/8" Hole Saw
SIMDMSC-3-PVC-NL	11/16" Shell Cutter for PVC (Asbestos Cement)
SIMDMSC-4-PVC-NL	7/8" Shell Cutter for PVC (Asbestos Cement)
SIMDMSC-5-PVC-NL	1-1/8" Shell Cutter for PVC (Asbestos Cement)
SIMDMSC-6-PVC-NL	1-3/8" Shell Cutter for PVC (Asbestos Cement)
SIMDMSC-7-PVC-NL	1-7/8" Shell Cutter for PVC (Asbestos Cement)
**SIMDMSC-6-PVC-HDPE-NL	1-3/8" Shell Cutter for PVC or HDPE
**SIMDMSC-7-PVC-HDPE-NL	1-7/8" Shell Cutter for PVC or HDPE
SIMDMBB-285-SS-NL	Stainless Steel Shaft with Dual Arbor - 28-1/2" Long
SIMDMPD-5-5-NL	1/4" Coupon Retaining Pilot Bit - 5-1/2" Long for HDPE

** Requires 5-1/2" long pilot bit (SIMDMPD-5-5-NL).

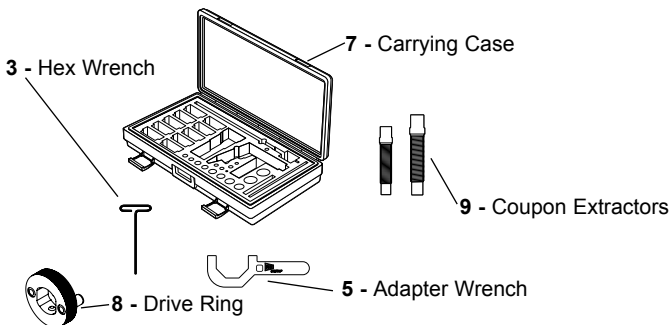
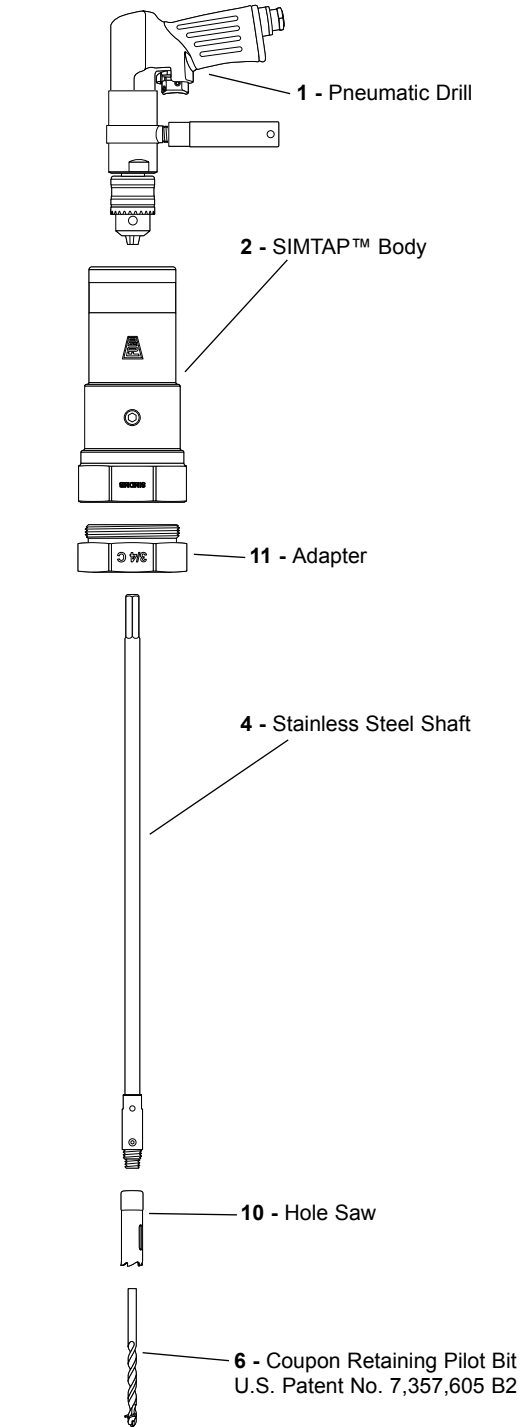

SIMTAP™ Options

CUTTING TOOLS

To select a cutting tool, choose the proper column for the type of water main, and select the nominal hole size. The proper cutting tool catalog number is in the far left column.

CATALOG NUMBER	DESCRIPTION	CORP STOP SIZE	TYPE OF WATER MAIN (NOMINAL HOLE SIZE)			
			PVC	IRON	ASBESTOS CEMENT	**HDPE
SIMDMHS-3-NL	11/16" Hole Saw	3/4"	-	3/4"	3/4"	-
SIMDMHS-4-NL	7/8" Hole Saw	1"	-	1"	1"	-
SIMDMHS-5-NL	1-1/8" Hole Saw	1-1/4"	-	1-1/4"	1-1/4"	-
SIMDMHS-6-NL	1-3/8" Hole Saw	1-1/2"	-	1-1/2"	1-1/2"	-
SIMDMHS-7-NL	1-7/8" Hole Saw	2"	-	2"	2"	-
SIMDMSC-3-PVC-NL	11/16" Shell Cutter for PVC	3/4"	3/4"	-	3/4"	3/4"
SIMDMSC-4-PVC-NL	7/8" Shell Cutter for PVC	1"	1"	-	1"	1"
SIMDMSC-5-PVC-NL	1-1/8" Shell Cutter for PVC	1-1/4"	1-1/4"	-	1-1/4"	1-1/4"
SIMDMSC-6-PVC-NL	1-3/8" Shell Cutter for PVC	1-1/2"	1-1/2"	-	1-1/2"	1-1/2"
SIMDMSC-7-PVC-NL	1-7/8" Shell Cutter for PVC	2"	2"	-	2"	2"
**SIMDMSC-6-PVC-HDPE-NL	1-3/8" Shell Cutter for PVC or HDPE	1-1/2"	1-1/2"	-	1-1/2"	1-1/2"
**SIMDMSC-7-PVC-HDPE-NL	1-7/8" Shell Cutter for PVC or HDPE	2"	2"	-	2"	2"

** See tables below when tapping HDPE pipe and choose the appropriate cutter based on wall thickness. When using the SIMDMSC-x-PVC-HDPE, the SIMDMPD-5-5-NL drill bit must also be used.

Highlighted cells indicate the need for an HDPE shell cutter (SIMDMSC-x-PVC-HDPE-NL).

HDPE Ductile Iron Pipe Size (PE4710) Wall Thickness

NOMINAL SIZE	AVG. OD	DR7	DR9	DR11	DR13.5	DR17	DR21	DR26	DR32.5
4	4.80	0.69	0.53	0.44	0.36	0.28	0.23	0.19	0.15
6	6.90	0.95	0.77	0.63	0.51	0.41	0.33	0.27	0.51
8	9.05	1.29	1.01	0.82	0.67	0.53	0.43	0.35	0.28
10	11.10	1.59	1.23	1.01	0.82	0.65	0.53	0.43	0.34
12	13.20	1.89	1.47	1.20	0.98	0.78	0.63	0.51	0.41
14	15.30	2.19	1.70	1.39	1.13	0.90	0.73	0.59	0.47
16	17.40	2.49	1.93	1.58	1.29	1.02	0.83	0.67	0.54
18	19.50	2.79	2.17	1.77	1.44	1.15	0.93	0.75	0.60
20	21.60	-	2.40	1.96	1.60	1.27	1.03	0.83	0.67
24	25.80	-	2.87	2.35	1.91	1.52	1.23	0.99	0.79
30	32.00	-	-	2.91	2.37	1.88	1.52	1.23	0.99
36	38.30	-	-	-	2.84	2.25	1.82	1.47	1.18
42	44.50	-	-	-	-	2.62	2.12	1.71	1.37
48	50.80	-	-	-	-	2.99	2.42	1.95	1.56

HDPE Steel Pipe Size (PE4710) Wall Thickness

NOMINAL SIZE	AVG. OD	DR7	DR9	DR11	DR13.5	DR17	DR21	DR26	DR32.5
4	4.50	0.64	0.50	0.41	0.33	0.27	0.21	0.17	0.14
6	6.63	0.95	0.74	0.60	0.49	0.39	0.32	0.26	0.20
8	8.63	1.23	0.96	0.78	0.64	0.51	0.41	0.33	0.27
10	10.75	1.54	1.19	0.98	0.80	0.63	0.51	0.41	0.33
12	12.75	1.82	1.42	1.16	0.94	0.75	0.61	0.49	0.39
14	14.00	2.00	1.56	1.27	1.04	0.82	0.67	0.54	0.43
16	16.00	2.29	1.78	1.46	1.19	0.94	0.76	0.62	0.49
18	18.00	2.57	2.00	1.64	1.33	1.06	0.86	0.69	0.55
20	20.00	2.86	2.22	1.82	1.48	1.18	0.95	0.77	0.62
24	24.00	3.43	2.67	2.18	1.78	1.41	1.14	0.92	0.74
26	26.00	-	2.89	2.36	1.93	1.53	1.24	1.00	0.80
28	28.00	-	3.11	2.55	2.07	1.65	1.33	1.08	0.86
30	30.00	-	3.33	2.73	2.22	1.77	1.43	1.15	0.92
36	36.00	-	-	3.27	2.67	2.12	1.71	1.39	1.11
42	42.00	-	-	-	-	2.47	2.00	1.62	1.29
48	48.00	-	-	-	-	2.82	2.29	1.85	1.48
54	54.00	-	-	-	-	3.18	2.57	2.08	1.62

SIMTAP™ ADAPTERS

To select an adapter, choose the proper column for the corporation body outlet thread type. The catalog number for the proper adapter is in the far left column.

CATALOG NUMBER	DESCRIPTION	COLOR	WT. LBS.
SIMDMA1-3-NL	3/4" Iron Pipe Thread Adapter	Red	1.41
SIMDMA1-4-NL	1" Iron Pipe Thread Adapter	Turquoise	1.37
SIMDMA1-5-NL	1-1/4" Iron Pipe Thread Adapter	Black	1.28
SIMDMA1-6-NL	1-1/2" Iron Pipe Thread Adapter	Brown	1.15
SIMDMA1-7-NL	2" Iron Pipe Thread Adapter	Gold	0.92
SIMDMA1-8-NL	2-1/2" Iron Pipe Thread Adapter	Silver	0.89
SIMDMA2-3-NL	3/4" Flare Copper Thread Adapter	Purple	1.41
SIMDMA2-4-NL	1" Flare Copper Thread Adapter	Grey	1.28
SIMDMA2-5-NL	1-1/4" Flare Copper Thread Adapter	Pink	1.24
SIMDMA2-6-NL	1-1/2" Flare Copper Thread Adapter	Orange	0.98
* Use SIMDMB-NL	2" Flare Copper Thread Adapter	-	-
SIMDMA4-5-Q-NL	1-1/4" CTS Quick Joint Thread Adapter	Silver	1.26
SIMDMA4-6-Q-NL	1-1/2" CTS Quick Joint Thread Adapter	Green	1.09
SIMDMA4-7-Q-NL	2" CTS Quick Joint Thread Adapter	Yellow	0.90
SIMDMA6-3-Q-NL	3/4" PEP Quick Joint Thread Adapter	Aqua	0.90
SIMDMA6-4-Q-NL	1" PEP Quick Joint Thread Adapter	Blue	1.20

* For 2" Flare Copper, use the SIMTAP™ body without an adapter.

The SIMTAP™ is compatible with all corporation stops complying with the AWWA C800 Standard. The SIMTAP™ also works on Ball Corporation Stops and most other valve types. Consult with factory for non-standard valve applications and adapter availability.

The Ford SIMTAP™ Drilling Machine

Operating and Assembly Instructions

DANGER: Do not use electric drill. Use of electric drill could result in shock or death. Follow the pipe manufacturer associations' installation and tapping/drilling recommendations.

- Remove the body from the case. The body is black in color and is identified by part number SIMDMB. The SIMTAP™ body serves a dual purpose. It is also the 2" Flare Copper Thread Adapter (item #1).
- Choose the appropriate adapter for the corporation stop to be tapped. The adapters are color anodized and labeled with the thread type for ease in identification. Double check to ensure the rubber O-ring is in place on the adapter. Screw the adapter (item #2) into the body and hand tighten.
- Remove the stainless steel shaft from the case and insert the 1/4" coupon-retaining pilot bit. **Be sure to slide the flat surface of the pilot bit (item #3) directly beneath the set screw.** Once in place, firmly tighten the set screw with hex wrench.
- Select the appropriate carbide tipped hole saw or shell cutter (item #4) for the pipe material and the desired hole size. Hole saws and cutters are generally 1/8" undersized (example: 1" tap uses a 7/8" diameter cutter). Place over the pilot bit and screw onto the shaft arbor.
- Take the hexed end of the shaft and extend it through the front of the machine (adapter end) until it extends all the way through the body. Proceed by pulling the shaft (item #5) from behind until the hole saw bottoms out inside the body.
- Affix the SIMTAP™ Machine to the valve and hand tighten. Open the corporation stop (making sure it is in the fully open position) and push the shaft through the valve **gently** until the pilot bit makes contact with the pipe. Connect your 1/2" drive power source and begin your tap. Always rotate clockwise applying no more force than required for the cutter to engage the pipe. When the tap is complete, open the chip flushing port with a 1/4" allen wrench and pull the power source back until the hole saw bottoms out inside the body. Close the corporation stop and remove your machine. Open the corporation stop to flush chips prior to service connection.

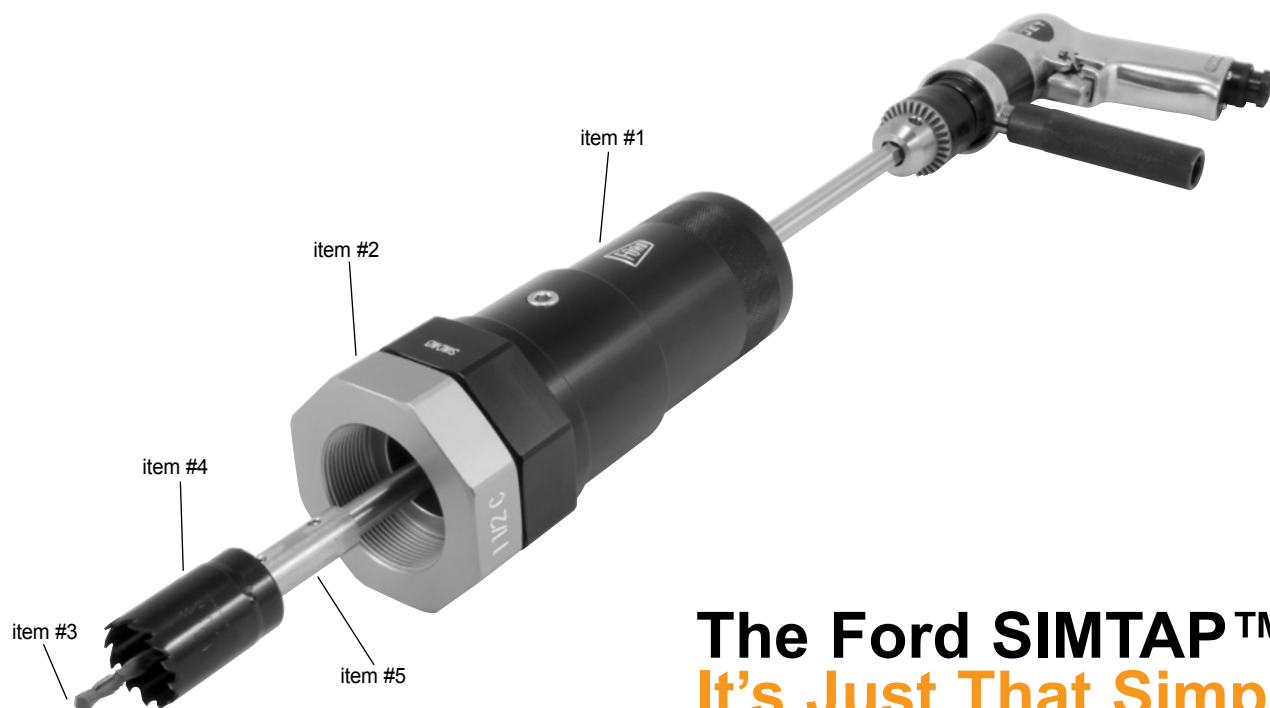

The Ford SIMTAP™
It's Just That Simple!

The Ford SIMTAP™ Drilling Machine

Operating and Assembly Instructions

Important Tips

- Maximum drill RPM is 650.
- Do not use with a hammer drill or impact driver.
- Do not reverse the drill. Only rotate in a clockwise direction.
- Do not use grease or lubricant that will allow chips to adhere to the cutters.
- For proper coupon retention, the full length of the pilot drill retaining wire must extend beyond the main cutter to allow proper gripping of the coupon (figure #1).
- To assist with cutter removal, remove the shaft from the machine body and slide the shaft through the square opening in the adapter wrench (figure #2) for leverage, and to prevent the shaft from turning while removing cutters.
- Use provided coupon extractor (figure #3) to free stuck coupons. After removing the pilot bit, remove the cutter from the shaft. Thread the appropriate extractor through the bottom of the cutter to release the coupon.
- Use caution when applying force to the machine to avoid drilling through the back side of the pipe.

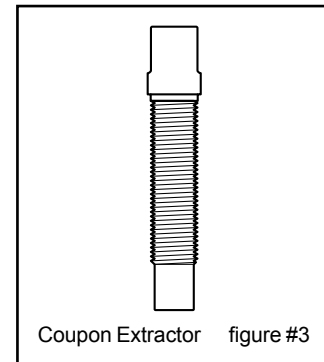
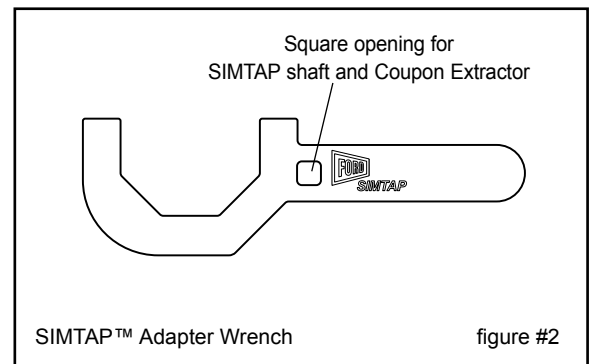
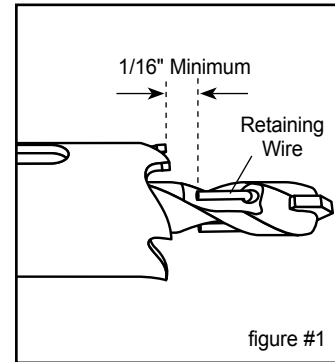

Drilling Machine Adapters

Recommended Drilling Machine Adapters

SIZE	FORD CORPORATION STOP NUMBER	OUTLET THREAD	MUELLER		ROMAC	RIDGID	REED	FORD	
			E-4 & E-5	D-4 & D-5	TAPMATE TOO	MLT3401	DM1100	MODEL 77	SIMTAP
FLARE COPPER THREAD OUTLET									
1/2"	F600-1, F700-1, F1000-1(-Q), F1100-1	1/2" Fl. Copper	63796	-	-	-	-	DMA2-1-NL	-
5/8"	F600-2, F1000-2(-Q)	5/8" Fl. Copper	-	-	-	-	-	DMA2-2-NL	-
5/8"x3/4"	F600-23, F1000-23	3/4" Fl. Copper	52019	37902	351-05-506	92097	08423	DMA2-3-NL	SIMDMA2-3-NL
3/4"	F600-3, F700-3, F1000-3(-Q), F1100-3(-Q), FB600-3, FB700-3, FB1000-3(-Q), FB1100-3(-Q)	3/4" Fl. Copper	52019	37902	351-05-506	92097	08423	DMA2-3-NL	SIMDMA2-3-NL
3/4"	F1001-3, F1101-3, F1002-3, F1102-3, FB1001-3, FB1101-3, FB1002-3, FB1102-3	1" Fl. Copper	36750	37903	351-05-508	92102	08424	DMA2-4-NL	SIMDMA2-4-NL
3/4"x1"	F600-34, F700-34, F1000-34(-Q), F1100-34, FB600-34, FB700-34, FB1000-34, FB1100-34	1" Fl. Copper	36750	37903	351-05-508	92102	08424	DMA2-4-NL	SIMDMA2-4-NL
1"	F600-4, F700-4, F1000-4(-Q), F1100-4(-Q), FB600-4, FB700-4, FB1000-4(-Q), FB1100-4(-Q)	1" Fl. Copper	36750	37903	351-05-508	92102	08424	DMA2-4-NL	SIMDMA2-4-NL
3/4"x1"	F1001-34, F1101-34, F1002-34, F1102-34	1-1/4" Fl. Copper	45385	37904	351-05-510	92107	-	DMA2-5-NL	SIMDMA2-5-NL
1"	F1001-4, F1101-4, F1002-4, F1102-4, FB1001-4, FB1101-4, FB1002-4, FB1102-4	1-1/4" Fl. Copper	45385	37904	351-05-510	92107	-	DMA2-5-NL	SIMDMA2-5-NL
1"x1-1/4"	F600-45, F700-45, F1000-45, F1100-45, FB600-45, FB700-45, FB1000-45, FB1100-45	1-1/4" Fl. Copper	45385	37904	351-05-510	92107	-	DMA2-5-NL	SIMDMA2-5-NL
1-1/4"	FB600-5, FB700-5	1-1/4" Fl. Copper	45385	37904	351-05-510	92107	-	DMA2-5F-SS-NL	SIMDMA2-5-NL
	FB1000-5, FB1100-5	1-1/4" Fl. Copper	45385	37904	351-05-510	92107	-	DMA2-5-NL	SIMDMA2-5-NL
	FB1001-5, FB1101-5	1-1/2" Fl. Copper	501947	37905	351-05-512	92112	08425	DMA2-6F-NL	SIMDMA2-6-NL
1-1/4"x1-1/2"	FB1002-5, FB1102-5	1-1/2" Fl. Copper	501947	37905	351-05-512	92112	08425	DMA2-6-NL	SIMDMA2-6-NL
	FB600-56, FB700-56, FB1000-56, FB1100-56	1-1/2" Fl. Copper	501947	37905	351-05-512	92112	08425	DMA2-6-NL	SIMDMA2-6-NL
1-1/2"	FB600-6, FB700-6, FB1000-6, FB1100-6, FB1002-6, FB1102-6	1-1/2" Fl. Copper	501947	37905	351-05-512	92112	08425	DMA2-6-NL	SIMDMA2-6-NL
	FB1001-6, FB1101-6	2" Fl. Copper	508201	37906	351-05-516	92117	08426	DMA2-7-NL	**See Note
1-1/2"x2"	FB600-67, FB700-67, FB1000-67, FB1100-67	2" Fl. Copper	508201	37906	351-05-516	92117	08426	DMA2-7-NL	**See Note
2"	FB600-7, FB700-7, FB1000-7, FB1100-7, FB1001-7, FB1101-7, FB1002-7, FB1102-7	2" Fl. Copper	508201	37906	351-05-516	92117	08426	DMA2-7-NL	**See Note
MALE IRON PIPE THREAD OUTLET									
1/2"	F400-1, F500-1	1/2" MIP	36967	-	-	-	-	DMA1-1-NL	-
	F800-1, F900-1	3/4" MIP	36919	36910	351-05-406	-	-	DMA1-3-NL	SIMDMA1-3-NL
1/2"x3/4"	F400-13, F500-13	3/4" MIP	36919	36910	351-05-406	-	-	DMA1-3-NL	SIMDMA1-3-NL
5/8"	F800-2	3/4" MIP	36919	36910	351-05-406	-	-	DMA1-3-NL	SIMDMA1-3-NL
	F400-3, F500-3, FB400-3, FB500-3	3/4" MIP	36919	36910	351-05-406	-	-	DMA1-3-NL	SIMDMA1-3-NL
3/4"	F800-3, F900-3, FB800-3, FB900-3	1" MIP	36917	36911	351-05-408	-	-	DMA1-4-NL	SIMDMA1-4-NL
	F400-34, FB400-34	1" MIP	36917	36911	351-05-408	-	-	DMA1-4-NL	SIMDMA1-4-NL
1"	F400-4, F500-4, FB400-4, FB500-4	1" MIP	36917	36911	351-05-408	-	-	DMA1-4-NL	SIMDMA1-4-NL
	F800-4, F900-4, FB800-4, FB900-4	1-1/4" MIP	36928	36912	351-05-410	-	-	DMA1-5-NL	SIMDMA1-5-NL
1-1/4"	FB400-5, FB500-5	1-1/4" MIP	36928	36912	351-05-410	-	-	DMA1-5F-SS-NL	SIMDMA1-5-NL
	FB800-5, FB900-5	1-1/2" MIP	501948	36913	351-05-412	-	08428	DMA1-6-NL	SIMDMA1-6-NL
1-1/2"	FB400-6, FB500-6	1-1/2" MIP	501948	36913	351-05-412	-	08428	DMA1-6-NL	SIMDMA1-6-NL
	FB800-6, FB900-6	2" MIP	508200	36525	351-05-416	-	08429	DMA1-67-NL	SIMDMA1-7-NL
2"	FB400-7, FB500-7	2" MIP	508200	36525	351-05-416	-	08429	DMA1-7-NL	SIMDMA1-7-NL
	FB800-7, FB900-7	2-1/2" MIP	-	36526	351-05-420	-	-	DMA1-78-NL	SIMDMA1-8-NL
FEMALE IRON PIPE THREAD OUTLET									
1/2"	F1700-1	1/2" FIP	36967	-	-	-	-	-	-
3/4"	F1600-3, F1700-3, FB1600-3, FB1700-3	3/4" FIP	36920	33556	351-05-606	-	-	-	-
3/4"x1"	FB1600-34, FB1700-34	1" FIP	36918	36323	351-05-608	-	-	DMA8-4-NL	-
1"	F1600-4, F1700-4, FB1600-4, FB1700-4	1" FIP	36918	36323	351-05-608	-	-	DMA8-4-NL	-
1"x1-1/4"	FB1600-45, FB1700-45	1-1/4" FIP	36733	36195	351-05-610	-	-	-	-
1-1/4"	FB1600-5, FB1700-5	1-1/4" FIP	36733	36195	351-05-610	-	-	-	-
1-1/4"x1-1/2"	FB1600-56, FB1700-56	1-1/2" FIP	503435	36196	351-05-612	-	-	DMA8-6-SS-NL	-
1-1/2"	FB1600-6, FB1700-6	1-1/2" FIP	503435	36196	351-05-612	-	-	DMA8-6-SS-NL	-
1-1/2"x2"	FB1600-67, FB1700-67	2" FIP	78907	36188	351-05-616	-	-	DMA8-7-SS-NL	-
2"	FB1600-7, FB1700-7	2" FIP	78907	36188	351-05-616	-	-	DMA8-7-SS-NL	-
2"x2-1/2"	FB1600-78, FB1700-78	2-1/2" FIP	-	-	-	-	-	-	-
SPECIAL THREAD OUTLET									
3/4"	F1001-3-Q, F1101-3-Q, FB1001-3-Q, FB1101-3-Q	3/4" Special Thread	508919	508917	-	-	08423	DMA6-3-Q-NL	SIMDMA6-3-Q-NL
1"	F1001-4-Q, F1101-4-Q, FB1001-4-Q, FB1101-4-Q	1" Special Thread	508920	508918	-	-	08424	DMA6-4-Q-NL	SIMDMA6-4-Q-NL
1-1/4"	FB1000-5-Q, FB1100-5-Q	1-1/4" Special Thread	-	-	-	-	-	*DMA4-5F-Q-SS-NL	SIMDMA4-5-Q-NL
1-1/2"	FB1000-6-Q, FB1100-6-Q	1-1/2" Special Thread	501949	507644	351-05-712	92157	08431	DMA4-6-Q-NL	SIMDMA4-6-Q-NL
2"	FB1000-7-Q, FB1100-7-Q	2" Special Thread	508199	507645	351-05-716	92162	08432	DMA4-7-Q-NL	SIMDMA4-7-Q-NL

* Requires DMBB-67-SS-NL Boring Bar

**Use the SIMTAP Drilling Machine Body without an adapter

Drilling Machine Adapters

Recommended Drill Sizes

For installation of Corporation Stops in Service Clamps or Saddles with a Drilling Machine

CORPORATION STOP SIZE	1/2"	5/8"	5/8"x3/4"	3/4"	3/4"x1"	1"	1-1/4"	1-1/2"	2"
Maximum Drill size for Stop with AWWA thread inlet	7/16"	9/16"	9/16"	11/16"	11/16"	15/16"	1-3/16"	1-7/16"	1-7/8"
Maximum Drill size for Stop with iron pipe thread inlet	7/16"	-	-	11/16"	11/16"	7/8"	1-3/16"	1-7/16"	1-7/8"

Recommended Tapping Machine Adapters

SIZE	FORD CORPORATION NUMBER	OUTLET THREADS	MUELLER			REED	RIDGID
			B-100 & B-101	B	A-2 & A-3	TM100	MLT3401
5/8"x3/4"	F1000	3/4" Fl. Copper	680600	680600	680600	98423	92182
3/4"	F (or FB) 1000, 1100	3/4" Fl. Copper	680600	680600	680600	98423	92182
3/4"	F (or FB) 1001, 1101, 1002, 1102	1" Fl. Copper	680601	680601	680601	98424	92187
3/4"x1"	F (or FB) 1000, 1100	1" Fl. Copper	680601	680601	680601	98424	92187
1"	F (or FB) 1000, 1100	1" Fl. Copper	680601	680601	680601	98424	92187
3/4"x1"	F1001, 1101, 1002, 1102	1-1/4" Fl. Copper	680602	-	680602	-	-
1"	F (or FB) 1001, 1101, 1002, 1102	1-1/4" Fl. Copper	680602	-	680602	-	-
1"x1-1/4"	F (or FB) 1000, 1100	1-1/4" Fl. Copper	680602	-	680602	-	-
1-1/4"	FB1000, 1100	1-1/4" Fl. Copper	680602	-	680602	-	-
1-1/4"	FB1001, 1101, 1002, 1102	1-1/2" Fl. Copper	-	-	88640	-	-
1-1/4"x1-1/2"	FB1000, 1100	1-1/2" Fl. Copper	-	-	88640	-	-
1-1/2"	FB1000, 1100, 1002, 1102	1-1/2" Fl. Copper	-	-	88640	-	-
1-1/2"	FB1001, 1101	2" Fl. Copper	-	-	88640	-	-
1-1/2"x2"	FB1000, 1100	2" Fl. Copper	-	-	88641	-	-
2"	FB1000, 1100	2" Fl. Copper	-	-	88641	-	-
2"	FB1001, 1101, 1002, 1102	2" Fl. Copper	-	-	88641	-	-
SPECIAL ADAPTERS							
3/4"	F (or FB) 1001-3-Q, 1101-3-Q	Special Thread	680688	-	-	98423	-
1"	F (or FB) 1001-4-Q, 1101-4-Q	Special Thread	680689	-	680689	98424	-
1-1/2"	FB1000-6-Q, 1100-6-Q	Special Thread	-	-	680421	-	-
2"	FB1000-7-Q, 1100-7-Q	Special Thread	-	-	680422	-	-

WARNING: Some tapping machine adapters, furnished by the tapping machine manufacturers, are not threaded all the way to the bottom of the adapter. This can cause problems when installing Ford Pack Joint and Grip Joint style corporation stops. If your adapter is **not** threaded to the bottom, a free washer-type screw plug adapter is available from Ford.

Section **AB**

Ford Drilling Machines

Warranty

All merchandise is warranted to be free from defects in material and factory workmanship for one year from date of shipment from our factory. We will provide, free of charge, new products in equal quantities for any that prove defective within one year from date of shipment from our factory. Manufacturer shall not be liable for any loss, damage, or injury, direct or consequential, arising out of the use of or the inability to use the product. Before using, user shall determine the suitability of the product for user's intended use and user assumes all risk and liability whatever in connection therewith. No claims for labor or consequential damage will be allowed. The foregoing may not be changed except by agreement signed by an officer of the manufacturer.

No other warranties are applicable or may be implied, including the implied warranty of merchantability and the implied warranty of fitness for particular purpose and any warranty relating to infringement or the like, all of which are disclaimed.

Parties responsible for monitoring and maintaining proper water system design must exercise full responsibility in understanding the full intent and scope of applicable lead laws.

Please Note:

Consult The Ford Meter Box Company, Inc. website (www.fordmeterbox.com) for the most recent catalog information. The Ford Meter Box Company considers the information in this catalog to be correct at the time of publication. Items and option availability, including specifications, are subject to change without notice. Please verify that your product information is current.



The Ford Meter Box Co., Inc. 775 Manchester Avenue, P.O. Box 443, Wabash, Indiana, USA 46992-0443
Telephone: 260-563-3171 FAX: 800-826-3487 Overseas FAX: 260-563-0167 www.fordmeterbox.com