

## STANDARD PUMP STARTER (SPS)



# SPS STANDARD PUMP STARTER

50/60 Hz, 1Ø & 3Ø, 120~600 VAC, 1~250 HP  
Service rated circuit breaker disconnect  
Adjustable overload with phase loss protection

## SUPERIOR PROTECTION, PROVEN RELIABILITY

### Rugged construction provides dependable operation

- Simple and functional control with heavy duty HOA switch
- Powder coated metal Type 3R enclosure available with optional pole mounting straps
- Ample space for adding additional controls

### Main circuit breaker disconnect rated for service entrance

- UL 489 circuit breaker provides branch and short circuit protection
- No fuses required – save time and money
- Lockable handle for safety
- UL listed for use as service equipment

### Reliable components ensure long life

- 2.5 million contactor electrical cycles at full rated current
- Contactor includes standard 1 N.O. and 1 N.C. auxiliary contacts
- NEMA size rated, available in NEMA sizes 1-5

### Thermal overload motor protection

- Differential phase failure protection
- Ambient temperature compensated: 41 °F - 104 °F (5 °C to 40 °C)
- Reset push button on door eliminates the need to access panel interior

## NEMA



### Standard control transformer (CPT) offers flexibility

- Multi-tap CPT input accepts all common motor voltages
- Integrated secondary protection – no fuses required
- 120 V control power available for additional field installed devices



### Standard Pump Starter (Combination) 120 - 460 V

UL/NEMA 3R Enclosures (Thermal Overload)

Model No.	UL HP / MAX SF AMPS										Overload Adjustment Range	Contactor NEMA Size	Wt. (lbs)	Description
	Single-Phase					Three-Phase								
	120 V		230 V		200 V		230 V		460 V					
SPS3R-S1-K-G15-9	1/3 HP	8 A	1 HP	8 A	2 HP	8 A	2 HP	8 A	5 HP	8 A	6-9 A	1	44	N3R SPS, S1, 8A, w/ HOA, TOL, CB Disc., & 50VA CPT
SPS3R-S1-K-G20-13	1/2 HP	11 A	1.5 HP	11 A	3 HP	11 A	3 HP	11 A	7.5 HP	11 A	9-13 A			N3R SPS, S1, 11A, w/ HOA, TOL, CB Disc., & 50VA CPT
SPS3R-S1-K-G30-18	1 HP	17 A	3 HP	17 A	-	-	5 HP	17 A	10 HP	17 A	12-18 A			N3R SPS, S1, 17A, w/ HOA, TOL, CB Disc., & 50VA CPT
SPS3R-S1-K-G40-22	1.5 HP	22 A	-	-	-	-	7.5 HP	22 A	15 HP	22 A	16-22 A			N3R SPS, S1, 22A, w/ HOA, TOL, CB Disc., & 50VA CPT
SPS3R-S1-K-G50-32	2 HP	24 A	5 HP	28 A	7.5 HP	25.3 A	10 HP	28 A	20 HP	27 A	22-32 A			N3R SPS, S1, 28A, w/ HOA, TOL, CB Disc., & 50VA CPT
SPS3R-S2-K-G40-22	1.5 HP	22 A	-	-	-	-	7.5 HP	22 A	15 HP	22 A	16-22 A	2	48	N3R SPS, S2, 22A, w/ HOA, TOL, CB Disc., & 50VA CPT
SPS3R-S2-K-G50-36	2 HP	28 A	5 HP	28 A	7.5 HP	28 A	10 HP	28 A	20 HP	28 A	24-36 A			N3R SPS, S2, 28A, w/ HOA, TOL, CB Disc., & 50VA CPT
SPS3R-S2-K-G60-36	3 HP	34 A	5 HP	34 A	10 HP	34 A	10 HP	34 A	25 HP	34 A	24-36 A			N3R SPS, S2, 34A, w/ HOA, TOL, CB Disc., & 50VA CPT
SPS3R-S2-K-G80-50	-	-	7.5 HP	45 A	-	-	15 HP	45 A	30 HP	45 A	34-50 A			N3R SPS, S2, 45A, w/ HOA, TOL, CB Disc., & 50VA CPT
SPS3R-S3-K-G80-50	-	-	7.5 HP	45 A	-	-	15 HP	45 A	30 HP	45 A	34-50 A			N3R SPS, S3, 45A, w/ HOA, TOL, CB Disc., & 100VA CPT
SPS3R-S3-K-G100-65	5 HP	57 A	10 HP	57 A	15 HP	57 A	20 HP	57 A	40 HP	57 A	45-65 A	3	64	N3R SPS, S3, 57A, w/ HOA, TOL, CB Disc., & 100VA CPT
SPS3R-S3-K-G125-75	5 HP	68 A	15 HP	68 A	20 HP	68 A	25 HP	68 A	50 HP	68 A	54-75 A			N3R SPS, S3, 68A, w/ HOA, TOL, CB Disc., & 100VA CPT
SPS3R-S3-K-G150-85	7.5 HP	80 A	15 HP	68 A	25 HP	85 A	30 HP	85 A	60 HP	77 A	63-85 A			N3R SPS, S3, 85A, w/ HOA, TOL, CB Disc., & 100VA CPT
SPS3R-S4-K-G150-85	7.5 HP	85 A	15 HP	85 A	25 HP	85 A	30 HP	85 A	60 HP	85 A	63-85 A			N3R SPS, S4, 85A, w/ HOA, TOL, CB Disc., & 100VA CPT
SPS3R-S4-K-G200-125	10 HP	114 A	25 HP	114 A	30 HP	114 A	40 HP	114 A	75 HP	114 A	95-130 A	4	68	N3R SPS, S4, 114A, w/ HOA, TOL, CB Disc., & 100VA CPT
SPS3R-S4-K-G250-150	15 HP	135 A	-	-	40 HP	120 A	50 HP	130 A	100 HP	124 A	110-150 A			N3R SPS, S4, 135A, w/ HOA, TOL, CB Disc., & 100VA CPT
SPS3R-S5-K-G300-180	-	-	-	-	50 HP	171 A	60 HP	171 A	125 HP	171 A	120-185 A			N3R SPS, S5, 171A, w/ HOA, TOL, CB Disc., & 200VA CPT
SPS3R-S5-K-G400-240	-	-	50 HP	216 A	75 HP	228 A	75 HP	228 A	150 HP	228 A	160-240 A	5	240	N3R SPS, S5, 228A, w/ HOA, TOL, CB Disc., & 200VA CPT
SPS3R-S5-K-G500-330	-	-	-	-	75 HP	285 A	100 HP	285 A	200 HP	285 A	200-330 A			N3R SPS, S5, 285A, w/ HOA, TOL, CB Disc., & 200VA CPT
SPS3R-S5P-K-G600-400	-	-	-	-	100 HP	342 A	125 HP	342 A	250 HP	342 A	260-400 A			N3R SPS, S5P, 342A, w/ HOA, TOL, CB Disc., & 200VA CPT
SPS3R-S5P-K-G800-400	-	-	-	-	125 HP	359 A	150 HP	360 A	300 HP	361 A	260-400 A	5+	382	N3R SPS, S5P, 361A, w/ HOA, TOL, CB Disc., & 200VA CPT

\* Note: Use MAX service factor amps when sizing for submersible motor applications. Consult factory for 575 V model numbers and information

### SPS Accessories

Model No.	Wt. (lbs)	Description
SPS-24	0	24 VAC Control Circuit
SPS-3FC	< 1	Three Float Switch Input Terminals for Simplex Operation
SPS-BCN	1	Optional Top Mount Alarm Beacon Light, 120 VAC
SPS-BZR	1	Optional Door Mounted Buzzer, 120 VAC w/ Silence Push Button
SPS-CLK-120V	1	Optional 7 Day, 24 Hr. Programmable Clock
SPS-CLK-24V	1	Optional 7 Day, 24 Hr. Programmable Clock
SPS-ENCL	8	Upgrade for S1 & S2 Panels to Larger 3R Enclosure, 32x15x8"
SPS-RLY-120VAC	< 1	Factory Installed 120 VAC Finder Interposing Run Relay
SPS-RLY-24VAC-DC	< 1	Factory Installed 24 VAC/VDC Finder Interposing Run Relay
SPS-RPL	< 1	Run Pilot Light
SPS-SPB	< 1	Start Push Button

## SPS Dimensions

Starter Size	H	W	D	Description
Size 1, Size 2	22	15	10	UL/NEMA 3R Enclosure
Size 3, Size 3+, Size 4	32	15	10	
Size 5, Size 5+	42	30	12	

\*All measurements in inches

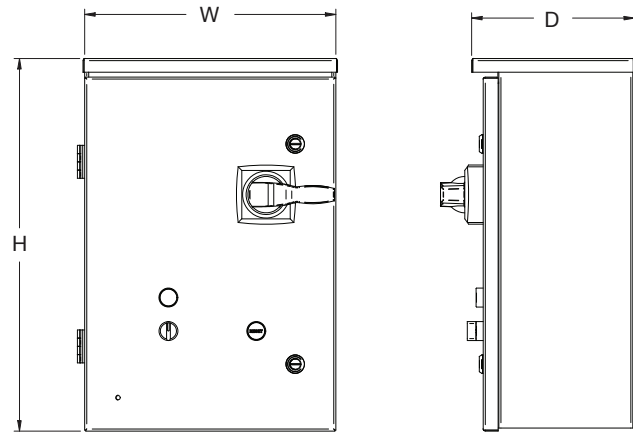

## Wiring Diagram

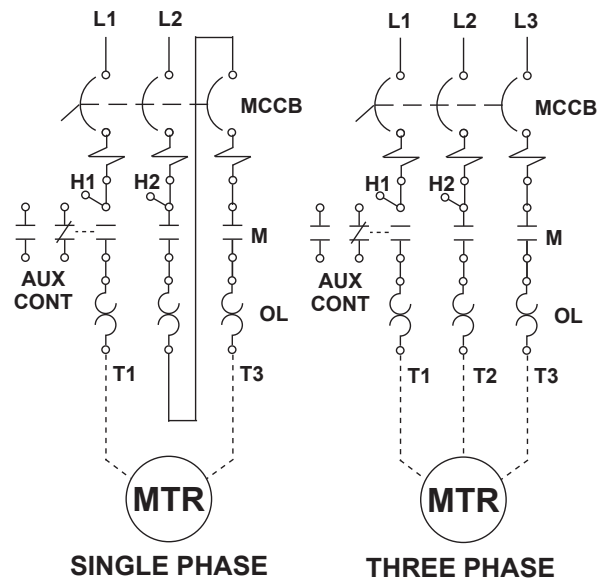
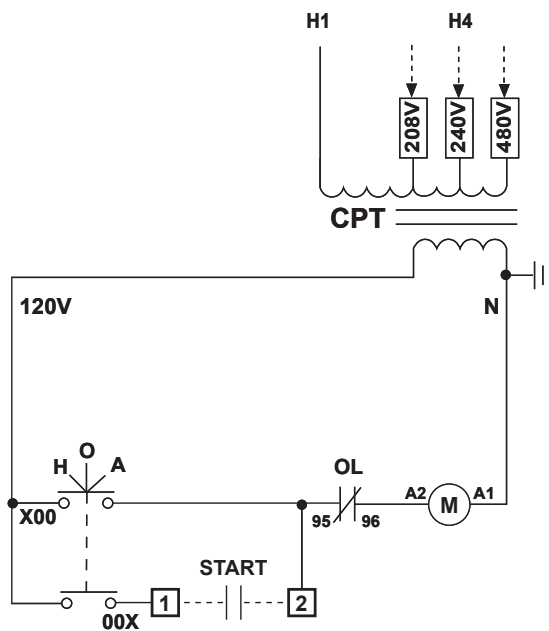

### SPS Specifications

Starter Type	
Standard Pump Starter	
Combination, Service Rated	
UL Type 3R Enclosure	

User Interface	
HOA Selector Switch	
Reset Push Button	

Standard Control Operations	
Auto Run Input	N.O. dry contact closure to energize starter
Environmental	
Ambient Operating Temp	-5 to 140 °F (-20 to 60 °C)
Ambient Storage Temp	-5 to 185 °F (-20 to 85 °C)
Relative Humidity	5% to 95% non-condensing

Protective Functions	
Overload Type	Thermal bi-metallic
Trip Class	Class 10
Reset	Manual
Phase Loss	Differential overload protection