

MAAX SUBMITTAL SPECIFICATIONS

Optik 7242

MODEL NUMBER 101275

DIMENSIONS: 72" x 42" x 24" Acrylic



Project :

Contractor :

MAAX Representative : Tel :

Date :

Vivez l'expérience
MAAX[®]
 Enjoy the experience

STANDARD FEATURES

- Sleek bathtub combines straight and curvaceous lines
- Inclined backrest, curvaceous armrests and deep bathing well
- Ample deck space for faucet installation
- Undermount or drop-in installation with center drain
- Two 12 in. grab bars option available
- Magnetic cushion available in black or white
- Magnet backed headrest for cushion. Factory installed only if cushion ordered on initial order

OPTIONS

- Thermo-Acoustic system
- Trim kit for Whirlpool and combined systems
- Two 12-in. grab bars available in many colors
- Two chromotherapy lights
- Flexible main hose for electronic control air massage - kit 15-ft. extension
- Metal trim kit for Aerofeel

UNIQUE FEATURES

- None

SYSTEMS

- Aerofeel Chromotherapy
- Combined Aerofeel/Hydrofeel
- Hydrofeel Hydrofeel REST

CERTIFICATIONS

Maax One has achieved one or more of the following certifications:



SELECTION

www.maax.com

2017-11-09

MAAX SUBMITTAL SPECIFICATIONS

Optik 7242

MODEL NUMBER 101275

TECHNICAL DRAWINGS

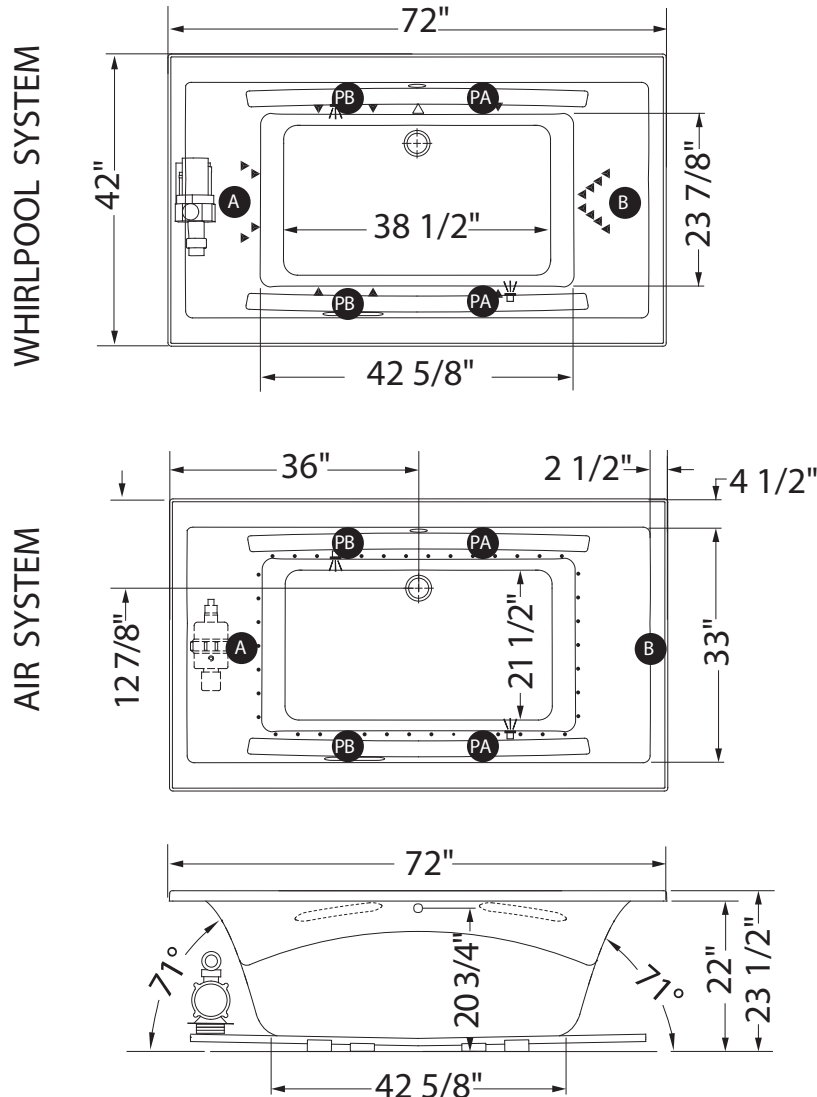

(A) : Specify blower and/or pump location when ordering

(B)

(PA)

(PB)

: With system, the optional grab bar is on opposite side of the pump.
 Without system, specify optional grab bar location when ordering.

(▲): Indicates whirlpool jets positioning

(△): Indicates suction positioning

(●): Indicates airjets positioning

(⌵): Indicates chromatherapy light positioning

Bathtub base includes anti-vibration Neutra-Phone leg supports (not shown).

Blower must be installed at a distance.

The back massage is on the opposite side of the blower position.

All dimensions are approximate. Structure measurements

must be verified against the unit to ensure proper fit.