

SOLD SEPARATELY

SOLD SEPARATELY OR BUILT IN

PrimeLine[®] SP

SPM & SPH SERIES



FEATURES

Self Priming Design: Features a replaceable check valve which acts to retain sufficient liquid in the casing to assure fast, reliable priming and repriming capabilities. Once initially primed the pump will reprime automatically.

Impeller and Wear Ring: Silicon Bronze construction, replaceable wear rings extend pump life, designed for maximum efficiency and repriming capabilities. Impeller is enclosed type, balanced for smooth operation, keyed to motor shaft.

Casing and Diffuser: Cast iron construction, featuring a back pull out design with tapped connections provided for casing fill and drain to simplify pump start up and removal at the end of the season. Top accessible pump feet for easy access to hold-down bolts. Casing o-ring sealing simplifies maintenance.

Shaft Sleeve: 300 series stainless steel replaceable sleeve provides motor shaft protection.

Mechanical Seal: Carbon/Ceramic faces, BUNA elastomers, 300 series stainless steel metal parts.



NSF 61 Certification: Pumps assembled at the factory are certified to the NSF/ANSI 61 Drinking Water System Components Standard. (Minimum usage of 2L/day. Buna seal models are not certified.)

APPLICATIONS

- Lawn irrigation
- Dewatering
- Liquid transfer
- Plot irrigation
- Livestock watering

SPECIFICATIONS

Pump

- Flows to 240 GPM
- Heads to 165 feet
- Reprime capabilities to 25'
- 2" through 3" suction
- 1½" through 2½" discharge
- Maximum temperature 160°F

Motor

- NEMA standard, JM shaft, Open Drip Proof* or Totally Enclosed Fan Cooled*.
- Single phase: 3 HP, 115/230 V; 5 HP, 230 V.
- Three phase: 3 and 5 HP, 208-230/460 V or 575 V.
- **Note:** Pump is not rated for 50 Hz service.

* Premium efficiency where required by Department of Energy regulations.

ORDERING INFORMATION

30 SP M 3 0 F

Built-in Suction Flange

Mechanical Seal Options

Seal Code	Rotary	Stationary	Elastomers	Metal Parts	Part No.
0	Carbon	Ceramic	BUNA	316SS	10K13
3		Sil-Carb	Viton		10K27
5					

Motor Type

1 = 1 PH, DP	6 = 3 PH, 575V TE	B = 1 PH, DP PE
2 = 1 PH, TE	7 = 3 PH, ODP PE	C = 1 PH, TE PE
3 = 3 PH, ODP	8 = 3 PH, 575 ODP PE	D = 3 PH, XP PE
4 = 3 PH, TE	9 = 3 PH, TE PE	E = 3 PH, WD PE
5 = 3 PH, 575V ODP	A = 3 PH, 575 TE PE	

M = Medium Head Impeller/Diffuser
H = High Head Impeller/Diffuser

Self Primer

Horsepower

30 = 3 HP
50 = 5 HP

Medium Head

Order Number	HP	PH	Enclosure	Voltage	Suction Flange
30SPM10	3	1	ODP*	115 / 230	SPF25
30SPM20		1	TEFC*	208-230	
30SPM70		3	ODP*	208-230/460	
30SPM90		3	TEFC*	208-230/460	
50SPM10	5	1	ODP*	230	SPF30
50SPM20		1	TEFC*	208-230	
50SPM70		3	ODP*	208-230/460	
50SPM90		3	TEFC*	208-230/460	

High Head

Order Number	HP	PH	Enclosure	Voltage	Suction Flange
30SPH10	3	1	ODP*	115 / 230	SPF20
30SPH20		1	TEFC*	208-230	
30SPH70		3	ODP*	208-230/460	
30SPH90		3	TEFC*	208-230/460	
50SPH10	5	1	ODP*	230	SPF25
50SPH20		1	TEFC*	208-230	
50SPH70		3	ODP*	208-230/460	
50SPH90		3	TEFC*	208-230/460	

Use standard Order No. for pump only or suction flange.
Add an F suffix to Order No. to order a pump with suction flange.

* Premium efficiency where required by Department of Energy regulations.

Strainer Basket

Order Number	Item
SPS83	Strainer Basket Only
SPS83F2	Basket with 2" FNPT flange
SPS83F3	Basket with 3" FNPT flange
SPF40	2" FNPT Flange Kit
SPF45	3" FNPT Flange Kit

PUMP PERFORMANCE (capacity in GPM)

3 HP High Head Model						
Model	PSI	Feet	5'	10'	15'	20'
30SPH1	20	46.2	138	136	130	*
	30	69.3	120	114	108	101
30SPH3	40	92.4	91	88	80	69
	50	115.5	57	47	32	20

* Operation not recommended at this point.

METERS FEET

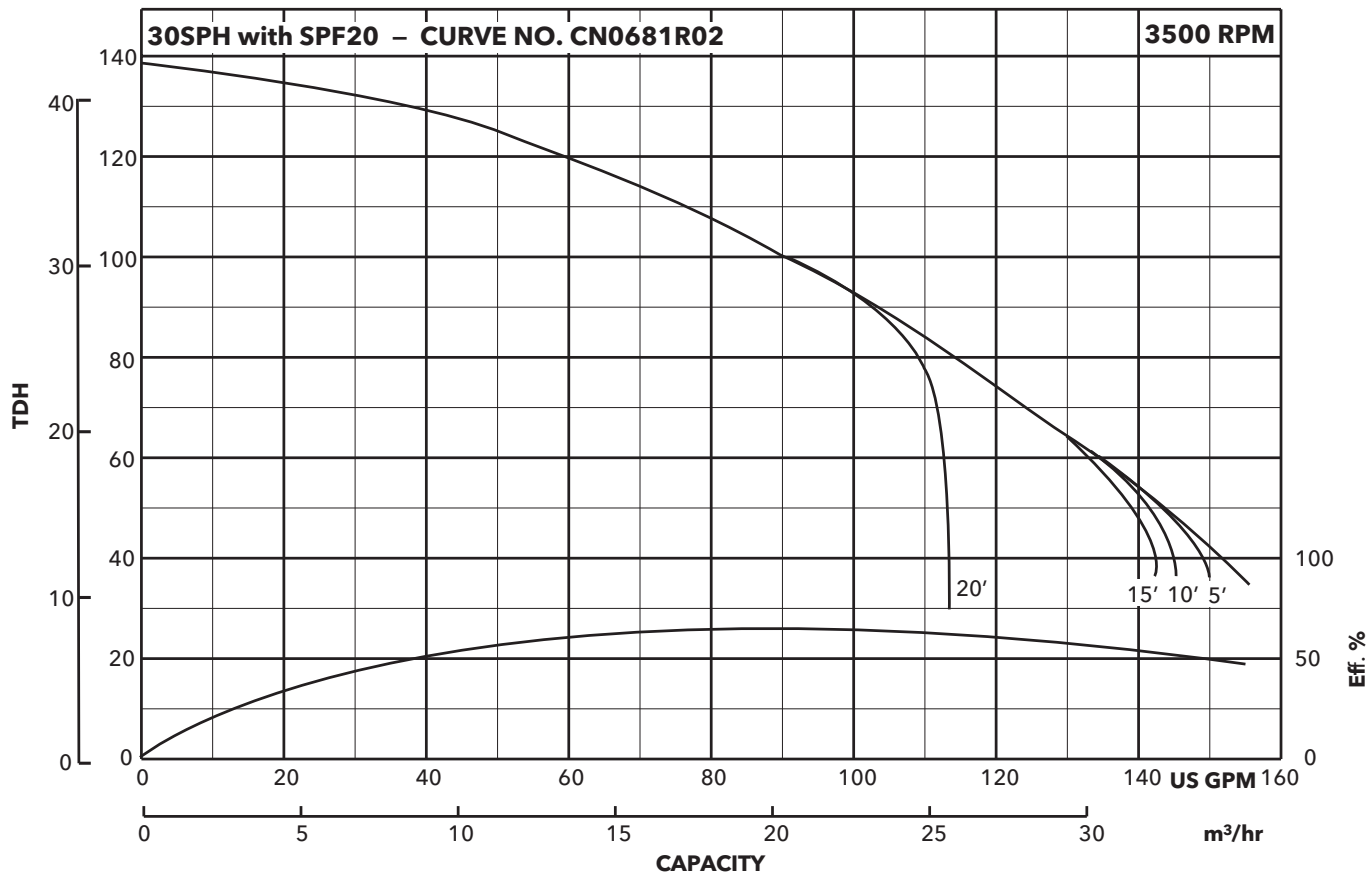

PUMP PERFORMANCE (capacity in GPM)

5 HP High Head Model							
Model	PSI	Feet	5'	10'	15'	20'	25'
50SPH1	20	46.2	182	176	*	*	*
	30	69.3	168	164	158	*	*
50SPH3	40	92.4	147	144	139	134	*
	50	115.5	120	118	114	108	96
	60	138.6	88	86	78	64	55

* Operation not recommended at this point.

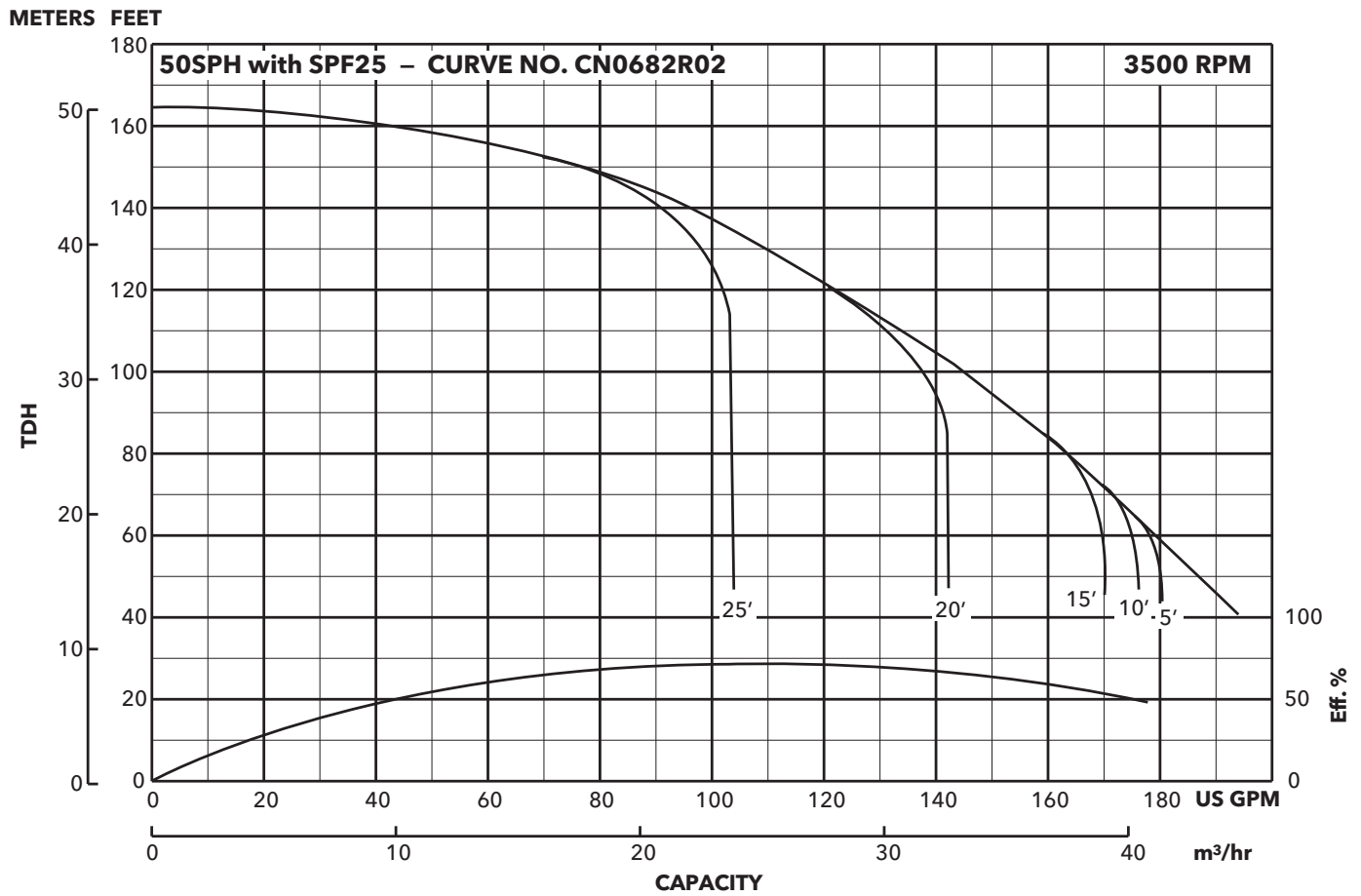

PUMP PERFORMANCE (capacity in GPM)

3 HP Medium Head Model							
Model	PSI	Feet	5'	10'	15'	20'	25'
30SPM1	20	46.2	163	155	147	138	114
30SPM3	30	69.3	127	117	107	95	84
	40	92.4	77	47	*	*	*

* Operation not recommended at this point.

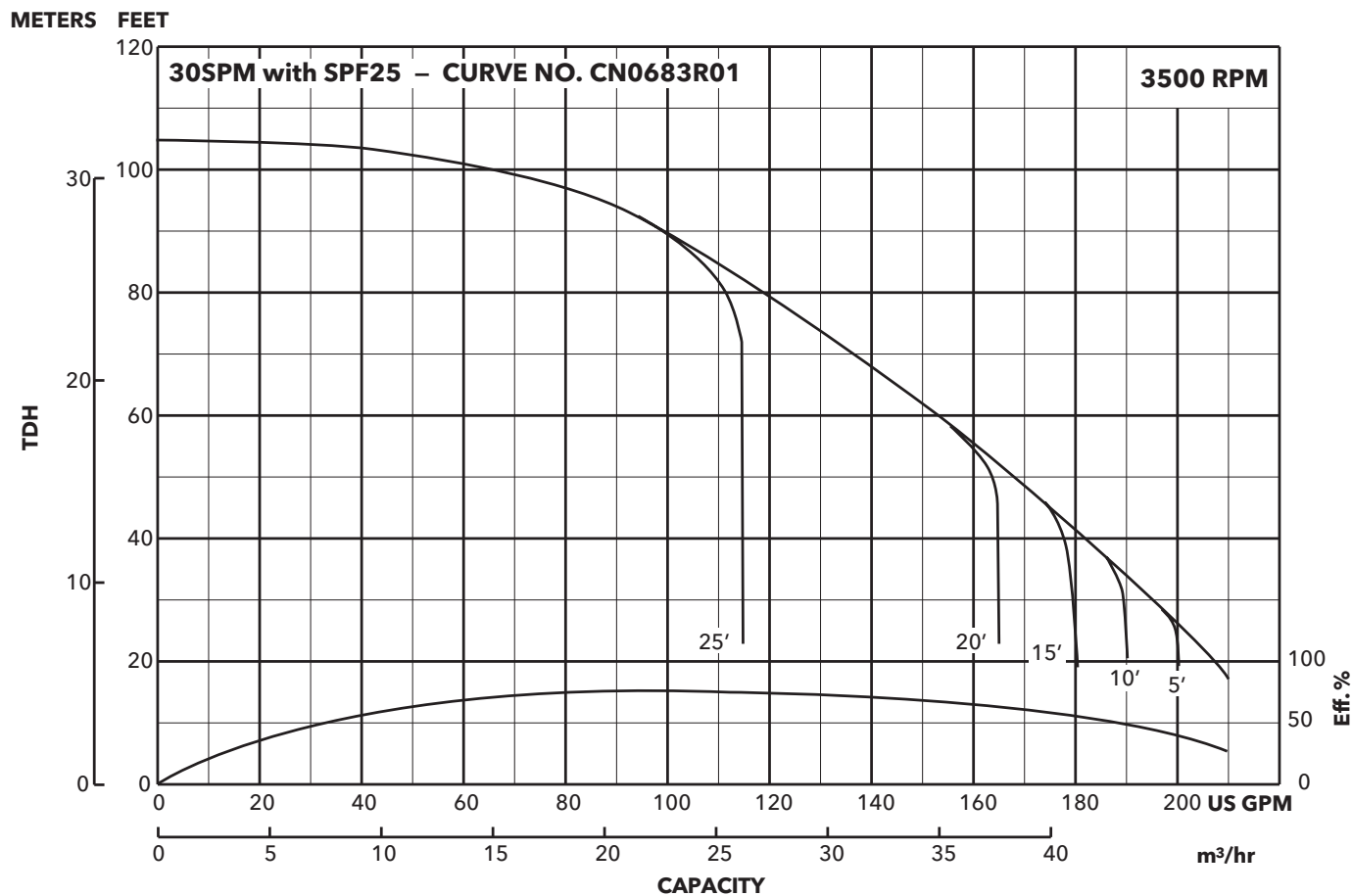

PUMP PERFORMANCE (capacity in GPM)

5 HP Medium Head Model							
Model	PSI	Feet	5'	10'	15'	20'	25'
50SPM1	20	46.2	218	211	202	167	*
	30	69.3	187	182	172	164	*
50SPM3	40	92.4	155	148	138	133	111
	50	115.5	119	107	96	90	65

* Operation not recommended at this point.

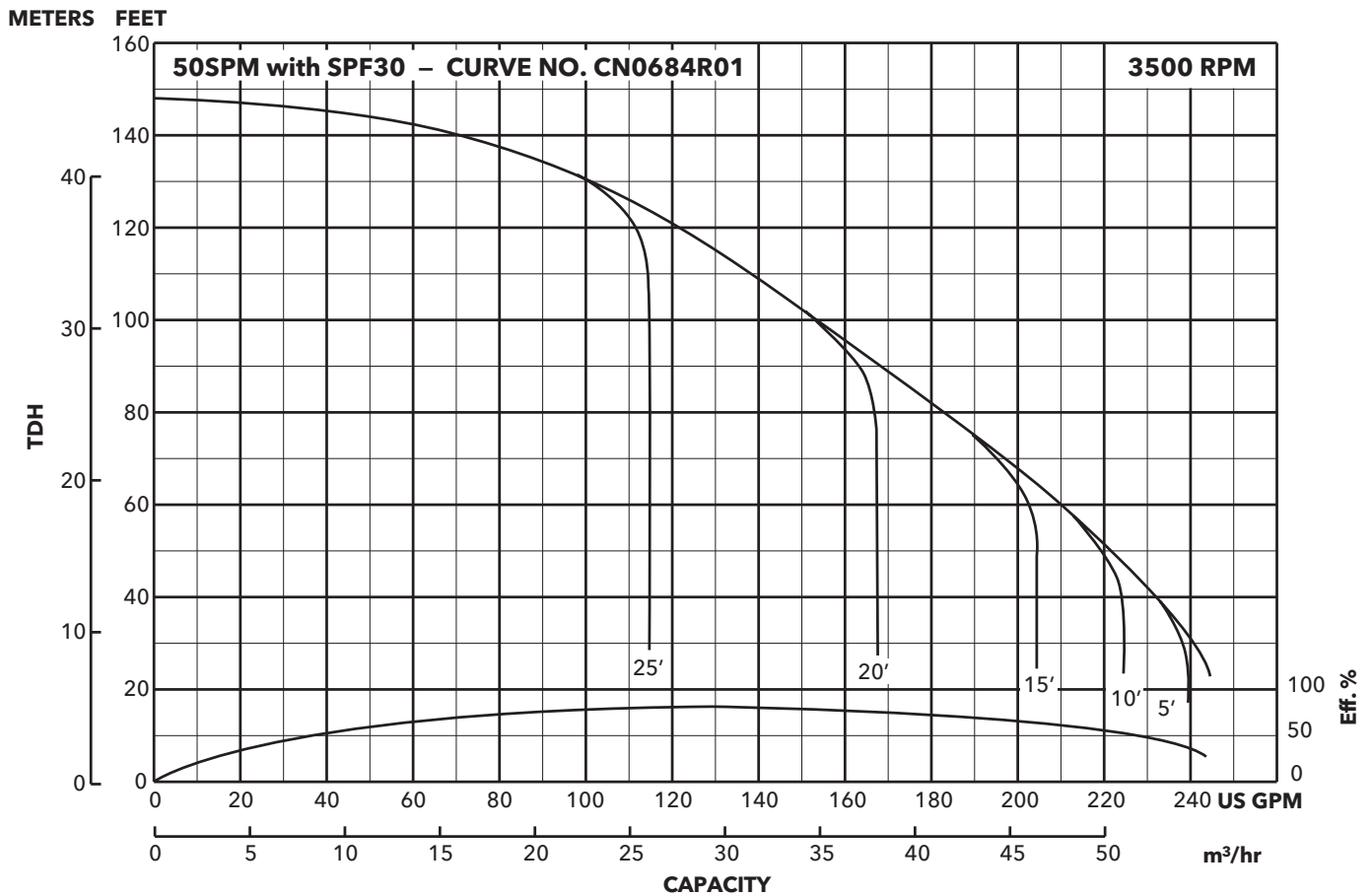

DIMENSIONS AND WEIGHTS

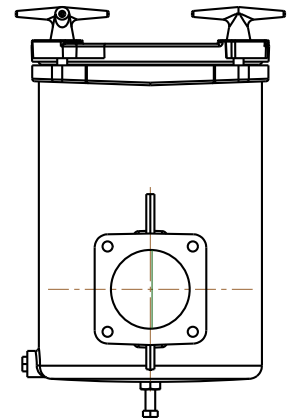
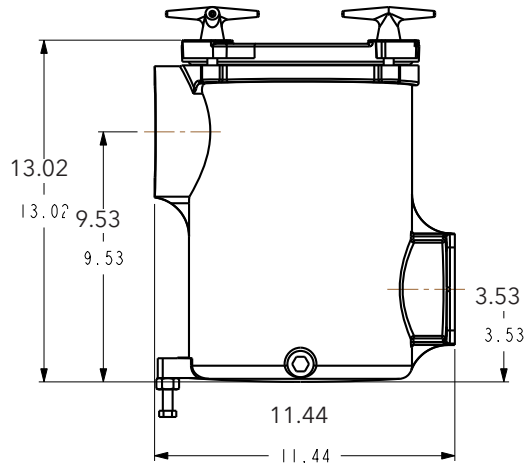
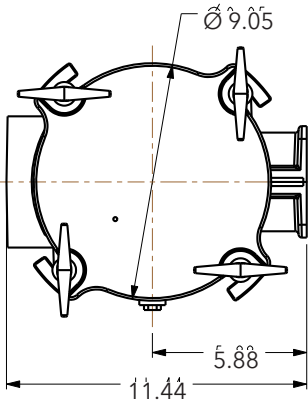
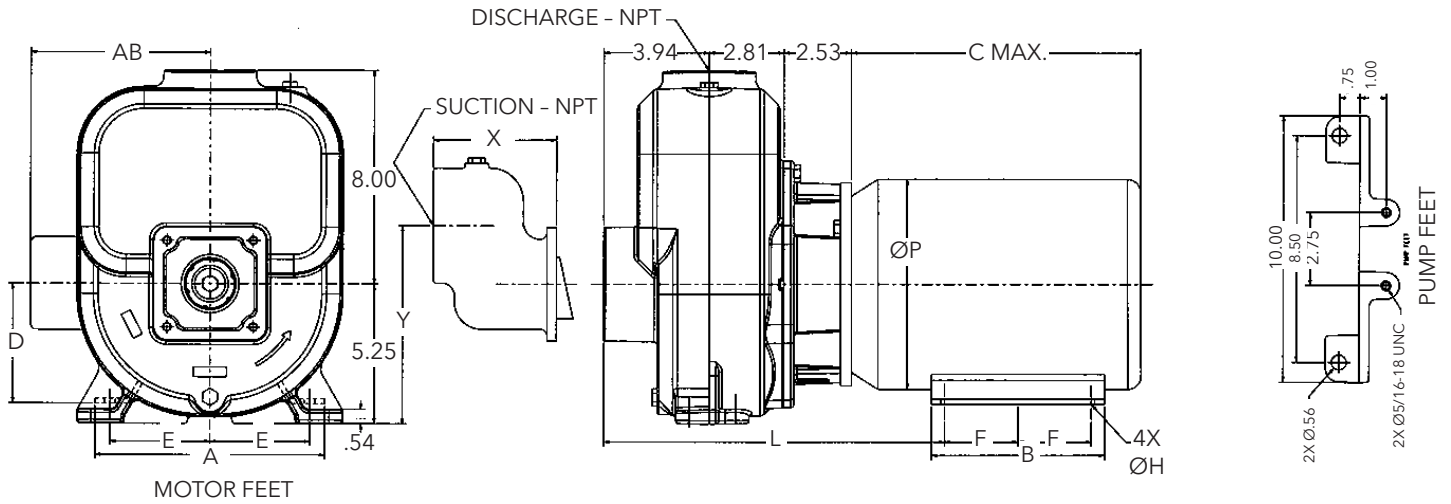

Pump Model	HP	PH	Suction	Disch.	A	AB	B	C MAX.	D	E	F	ØH	L	ØP	X	Y	Wt. (lbs.)
30SPH1	3	1	2	1½	8.63	6.87	6.50	12.56	4.50	3.75	2.75	0.41	12.78	7.88	3.58	6.50	135
30SPH3		3			6.50	5.61	5.94		3.50	2.75	2.50	0.34	12.16	6.62			115
30SPM1		1	2½	2	8.63	6.87	6.50	13.80	4.50	3.75	2.75	0.41	12.78	7.88	4.62	7.44	135
30SPM3	3	5.73				6.62								115			
50SPH1	5	1	2	2	8.63	6.50	13.80	4.50	3.75	2.75	0.41	12.78	7.88	4.62	7.44	155	
50SPH3		3														5.85	135
50SPM1		1	3	2½	8.63	6.87	13.80	4.50	3.75	2.75	0.41	12.78	7.88	4.62	7.44	155	
50SPM3	3	135															

NOTES: Dimensions are approximate, not for construction purposes.

xylem
Let's Solve Water

Xylem Inc.
2881 East Bayard Street Ext., Suite A
Seneca Falls, NY 13148
Phone: (800) 453-6777
Fax: (888) 322-5877
www.gouldswatertechnology.com

Goulds is a registered trademark of Goulds Pumps, Inc. and is used under license.
PrimeLine is a trademark of Xylem Inc. or one of its subsidiaries.
© 2018 Xylem Inc. BSPMSPH R6 January 2018