

Unit Heater

Accessories & Replacement Parts

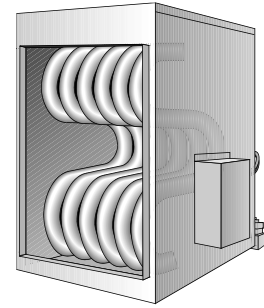
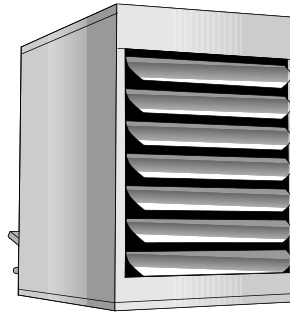
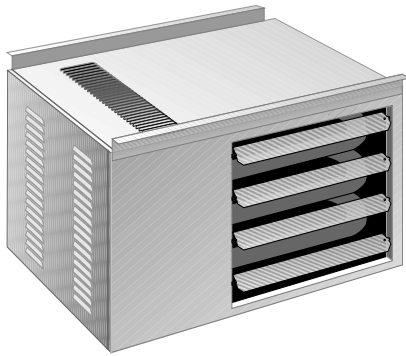

Contents	Page
CUH Unit Heater.....	2
FSA Unit Heater	4
SEP Unit Heater	
SEP 60 – 145.....	6
SEP 175 – 290.....	10
SEP 300 – 400.....	14
HED Duct Furnace	
HED 75 – 150	18
HED 200 – 300	20
FOA Unit Heater	22
UHRS Unit Heater	26
UHCM Unit Heater.....	27
FOA Venting Guidelines	27
SEP, HED, FSA Venting Guidelines	28
SEP, FSA, FOA Conversion Kits – LP and NG.....	30-31
UHRS, UHCM Conversion Kits – LP and NG	32

CUH

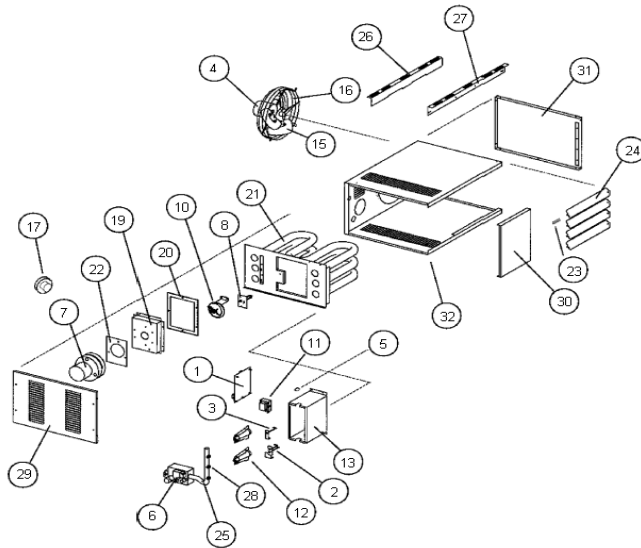

CUH UNIT HEATER

DRAWING NUMBER	DESCRIPTION	PART NUMBER	CUH30					CUH45					CUH60		CUH75		
			1	2	3	4	5	1	2	3	4	5	1	2	1	2	
1	CONTROL BOARD	176777500 76722700	X					X					X			X	
2	ELECTRODE/SPARK IGNITOR	176738700 76714900	X					X				X			X		X
3	ELECTRODE/FLAME SENSOR	176738800 76715000	X					X				X			X		X
4	FAN MOTOR (BLOWER MOTOR)	76791000 176700242	X					X				X			X		X
5	FLAME ROLLOUT SWITCH	176740200 176739900												2		2	
6	GAS VALVE (LP)	76717500	X					X				X			X		X
6	GAS VALVE (NAT)	76714600	X					X				X			X		X
28	ORIFICE (LP)	176717200 76724000		2					3			4			5		
28	ORIFICE (NAT)	176712200 76723700			2					3			4			5	
Not Shown	IGNITION LEAD (WIRE, CABLE)	76715100	X					X				X			X		X
Not Shown	Wiring Harness	176722900				X					X			X			X
7	INDUCED DRAFT MOTOR ASSEMBLY(includes motor, housing, & blower wheel)	76739200	X					X				X			X		X
8	LIMIT SWITCH	76739700	X					X				X			X		X
10	PRESSURE SWITCH	176777300 76777400															X
11	TRANSFORMER	76715500	X					X				X			X		X
12	BURNER	76739500	2					3				4			5		
13	BURNER BOX	176773700 176773800	X					X						X			X

CUH UNIT HEATER

DRAWING NUMBER	DESCRIPTION	PART NUMBER	CUH30					CUH45					CUH60		CUH75		
			1	2	3	4	5	1	2	3	4	5	1	2	1	2	
15	FAN BLADE	176739100						X									
		176739600		X													
		176740000										X					
		176701184														X	
16	FAN GUARD	176739000		X				X									
		176740100									X			X			
17	FLUE ADAPTER	176737800									X			X			
		176735000		X				X									
19	FLUE BOX	176740400		X				X									
		176741200									X						
		176741900													X		
20	FLUE BOX GASKET	176739300		X				X									
		176740300									X			X			
21	HEAT EXCHANGER	176700314		X													
		176781500						X									
		176784000									X						
		176768700													X		
22	INDUCED DRAFT GASKET	176708800		X				X			X		X				
23	LOUVER SPRING	76713500		4					4		6		6				
24	LOUVER VANE (BEIGE)	176741100		4					4		6		6				
25	MANIFOLD ** For these models, you also need to order tapered thread orifices. (All new manifolds have tapered threads and will not fit with older orifices having straight threads)	176773900		X *	X												
		176774000						X *	X								
		176774100									X *	X					
		176774200												X *	X		
26	MOUNTING BRACKET, BACK	176750900		X				X			X		X				
27	MOUNTING BRACKET, FRONT	176750800		X				X			X		X				
29	PANEL, ACCESS	176740500		X				X									
		176758900									X		X				
30	PANEL, FRONT	176750700		X				X									
		176758800									X		X				
31	PANEL, SIDE	176750600		X				X									
		176758100									X		X				
32	WRAPPER, CABINET	176750400		X				X									
		176758700									X		X				

FSA

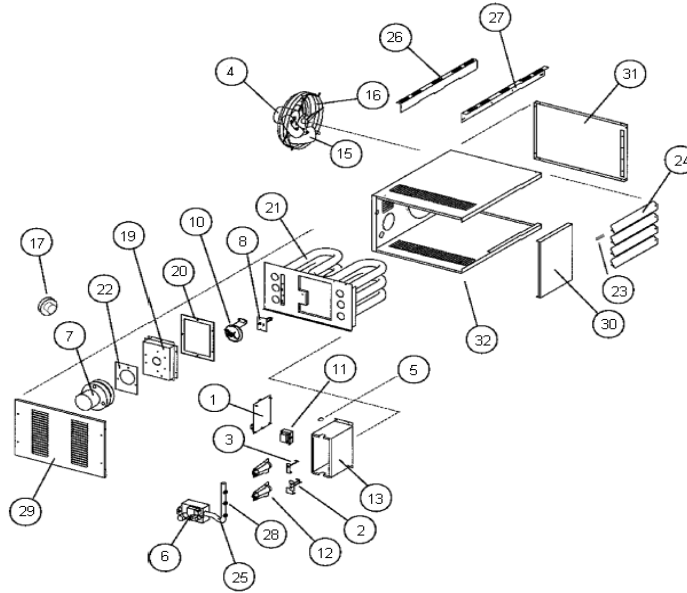

FSA UNIT HEATER

DRAWING NUMBER	DESCRIPTION	PART NUMBER	FSA30	FSA45	FSA60	FSA75
1	CONTROL BOARD					
		76722700			X	
2	ELECTRODE/SPARK IGNITER					
		76714900			X	
3	ELECTRODE/FLAME SENSOR					
		76715000			X	
4	FAN MOTOR (BLOWER MOTOR)					
		76791000	X	X		
		176700242			X	X
5	FLAME ROLLOUT SWITCH					
		176740200			2	2
		176739900	X	X		
6	GAS VALVE (LP)					
		76717500			X	
6	GAS VALVE (NAT)					
		76714600			X	
28	ORIFICE (LP)					
		76724000	2	3	4	5
28	ORIFICE (NAT)					
		76723700	2	3	4	5
Not Shown	IGNITION LEAD					
		76715100			X	
7	INDUCED DRAFT MOTOR ASSEMBLY (includes motor, housing, & blower wheel)					
		76739200			X	
8	LIMIT SWITCH					
		76739700			X	
10	PRESSURE SWITCH					
		176777300				X
		176777400	X	X	X	
11	TRANSFORMER					
		76715500			X	
12	BURNER					
		76739500	2	3	4	5
13	BURNER BOX					
		176773700	X	X		
		176773800			X	X

FSA UNIT HEATER

DRAWING NUMBER	DESCRIPTION	PART NUMBER	FSA30	FSA45	FSA60	FSA75
15	FAN BLADE					
		176739100		X		
		176739600	X			
		176740000			X	
		176701184				X
16	FAN GUARD					
		176739000	X	X		
		176740100			X	X
17	FLUE ADAPTER					
		176737800			X	X
		176735000	X	X		
19	FLUE BOX					
		176740400	X	X		
		176741200			X	
		176741900				X
20	FLUE BOX GASKET					
		176739300	X	X		
		176740300			X	X
21	HEAT EXCHANGER					
		176700314	X			
		176781500		X		
		176784000			X	
		176768700				X
22	INDUCED DRAFT GASKET					
		176708800	X	X	X	X
23	LOUVER SPRING					
		76713500	4	4	6	6
24	LOUVER VANE (BEIGE)					
		176741100	4	4	6	6
25	MANIFOLD					
		176773900	X			
		176774000		X		
		176774100			X	
		176774200				X
26	MOUNTING BRACKET, BACK					
		176750900			X	
27	MOUNTING BRACKET, FRONT					
		176750800			X	
29	PANEL, ACCESS					
		176740500	X	X		
		176758900			X	X
30	PANEL, FRONT					
		176750700	X	X		
		176758800			X	X
31	PANEL, SIDE					
		176750600	X	X		
		176758100			X	X
32	WRAPPER, CABINET					
		176750400	X	X		
		176758700			X	X
Not Shown	FLAME SENSOR WIRE					
		176738500			X	
Not Shown	WIRE HARNESS					
		176722900			X	X

SEP

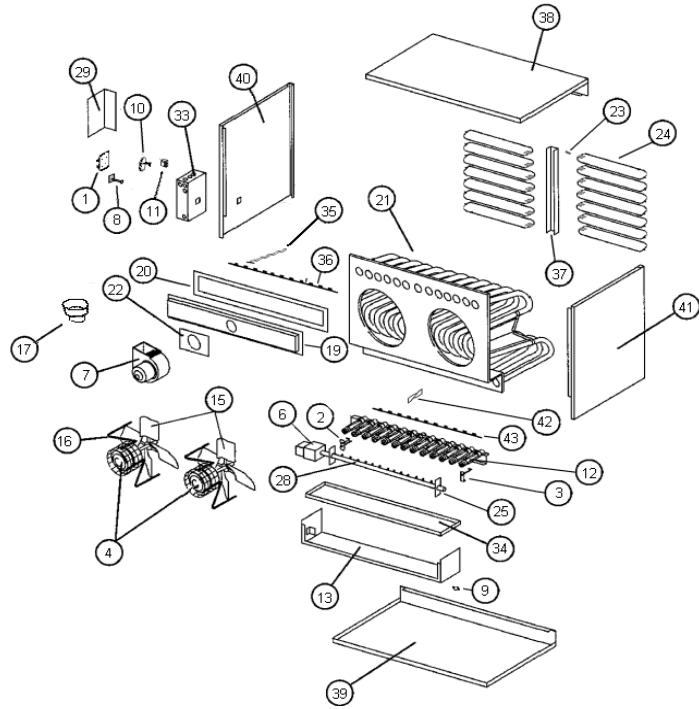

SEP UNIT HEATER SEP 60 - 145

DRAWING NUMBER	DESCRIPTION	PART NUMBER	SEP 60					SEP 90					SEP 100					SEP 115					SEP 145						
			1	2	3	4	5	1	2	3	4	5	1	2	3	4	5	1	2	3	4	5	1	2	3	4	5		
ALUMINIZED STEEL HEAT EXCHANGER																													
STAINLESS STEEL HEAT EXCHANGER						0	1					0	1							0	1						0	1	
1	CONTROL BOARD																												
		10000240	X					X										X						X					
		176777500			X				X										X						X				
		76722700					X					X	X						X									X	
2	ELECTRODE/SPARK IGNITER																												
		76714900		X					X			X						X						X				X	
3	ELECTRODE/FLAME SENSOR																												
		76715000		X					X			X						X					X				X		
4	FAN MOTOR (BLOWER MOTOR)																												
		76714500		X					X			X						X					X				X		
6	GAS VALVE (LP)																												
		76717500		X					X			X						X					X				X		
		176717600																											
6	GAS VALVE (NAT)																												
		76714600		X					X			X						X					X				X		
		76714800																											
28	ORIFICE (NAT)																												
	Straight thread	176712300																	4								5		
	Tapered thread	76723000																			4								5
	Straight thread	176712200			4				6																				
	Tapered thread	76723700					4							6															
	Straight thread	176712400																											
	Tapered thread	76723400																											
	Tapered thread	76723600																4											
28	ORIFICE (LP)																												
	Straight thread	176717200		4					6																				
	Tapered thread	76724000						4						6															
	Tapered thread	176723500																4											
	Straight thread	76717300																								4		5	
	Tapered thread	76723100																									4		5
	Straight thread	176717400																											
	Tapered thread	176723300																											

SEP UNIT HEATER SEP 60 - 145

DRAWING NUMBER	DESCRIPTION	PART NUMBER	SEP 60					SEP 90					SEP 100	SEP 115					SEP 145						
			1	2	3	4	5	1	2	3	4	5		1	2	3	4	5	1	2	3	4	5		
ALUMINIZED STEEL HEAT EXCHANGER																									
STAINLESS STEEL HEAT EXCHANGER						0	1					0	1					0	1					0	1
7	INDUCED DRAFT MOTOR ASSEMBLY (includes motor, housing, & blower wheel)	76746100	X					X						X					X						
		76714300A																							
		76738400																							
		76714200				X					X		X									X			
8	LIMIT SWITCH	176716600																							
		76716400		X					X				X									X			
		176716700																							
		176716500																							
9	AUXILIARY LIMIT (ROLLOUT)	176717100																							
10	PRESSURE SWITCH	176776900																							
		176777000																							
		176777100							X				X			X									
		176777200																					X		
		176777300		X						X			X							X					
11	TRANSFORMER	76715500		X					X				X							X			X		
12	BURNER	76711200			4					6															
		76711300												4					4				5		
15	FAN BLADE	176710700		X					X																
		176776400											X					X					X		
16	FAN MOTOR MOUNT / GUARD	176711000		X					X																
		176711100											X					X					X		
17	FLUE ADAPTER	1 76735000		X																					
		76708500								X			X					X					X		
		76708600																							
		76708700																							
19	FLUE BOX	176709100	X							X															
		176709000			X																				
		176718900						X					X												
		176709200														X									
		176719100																	X						
		176709300																				X			
		176721300																							
		176709400																							
		176709500																							
		176736600																							
		176709600																							
		176736700																							
		176709700																							
		176709800																							
		176709900																							

SEP UNIT HEATER SEP 60 - 145

DRAWING NUMBER	DESCRIPTION	PART NUMBER	SEP 60					SEP 90					SEP 100	SEP 115					SEP 145								
			1	2	3	4	5	1	2	3	4	5		1	2	3	4	5	1	2	3	4	5				
	ALUMINIZED STEEL HEAT EXCHANGER																										
	STAINLESS STEEL HEAT EXCHANGER					0	1					0	1					0	1						0	1	
20	FLUE BOX GASKET																										
		176710000				X					X																
		176710100											X					X							X		
		176710200																									
		176710300																									
22	INDUCED DRAFT MOTOR GASKET																										
		176708800				X					X				X			X						X			
		176708900																									
Not Shown	SILICONE TUBING																										
		176742001				X					X			X			X					X			X		
21	HEAT EXCHANGER (ALUMINIZED)																										
		176707300				X																					
		176707400									n/a																
		176707500											X				X										
		176707600																							X		
		176707700																									
		176707800																									
		176707900																									
		176708000																									
21	HEAT EXCHANGER (STAINLESS)																										
		176711400					X																				
		176711500									n/a																
		176711600											X				X										
		176711700																							X		
		176708100																									
		176708200																									
		176711900																									
		176708300																									
23	LOUVER SPRING																										
		76713500					7					7	7				7								7		
24	LOUVER VANE, BEIGE																										
		176713100					7					7															
		176713200											7					7								7	
		176713300																									
		176713400																									
25	MANIFOLD																										
	* For these models, you also need to order tapered thread orifices. (All new manifolds have tapered threads and will not fit with older orifices having straight threads).	176724800				X*		X																			
		176724700									X*		X														
		176724400												X				X*		X							
		176724500																							X*		X
		176724600																									
		176724100																									
		176724200																									
		176724300																									

SEP UNIT HEATER SEP 60 - 145

DRAWING NUMBER	DESCRIPTION	PART NUMBER	SEP 60					SEP 90					SEP 100	SEP 115					SEP 145					
			1	2	3	4	5	1	2	3	4	5		1	2	3	4	5	1	2	3	4	5	
	ALUMINIZED STEEL HEAT EXCHANGER																							
	STAINLESS STEEL HEAT EXCHANGER				0	1				0	1								0	1			0	1
29	CONTROL BOX COVER	176712600			X				X		X		X					X				X		
33	CONTROL BOX	176712500			X				X		X		X					X				X		
34	DRIP SHIELD	176712700			X				X															
		176712800									X						X					X		
		176712900																						
		176713000																						
35	FLUE BAFFLE	176710400										4				4						5		
36	FLUE BAFFLE BRACKET	176710500									X					X						X		
		176710600																						
37	LOUVER BRACKET	176714100																						
38	PANEL, TOP	176701000					X																	
		176700900									X							X						
		176701100																						
		176700800																						
39	PANEL, BOTTOM	176701500					X																	
		176701300									X					X						X		
		176701400																						
		176701200																						
40	PANEL, LEFT SIDE (viewed from rear)	176701900			X				X															
		176702100									X					X						X		
		176702000																						
41	PANEL, RIGHT SIDE (viewed from rear)	176701600			X				X															
		176701800									X					X						X		
		176701800																						
42	TURBULATOR FOR NOX	176717800										4				4						5		
43	TURBULATOR RETAINER	176717900										X				X						X		
Not Shown	FAN TIMER	100002477	X					X					X								X			
Not Shown	GAS PRESSURE SWITCH	76717700			X				X		X					X						X		
Not Shown	IGNITION WIRE	100000546	X					X					X					X			X			
		76715100			X				X		X					X						X		
		76715200																						
Not Shown	FLAME SENSOR WIRE	100000547	X					X					X					X			X			
		100000548																						
		176738500				X				X	X						X						X	
		176738600																						
Not Shown	WIRING HARNESS	176722900				X				X	X						X						X	
		176717000																						
		176722800																						

SEP

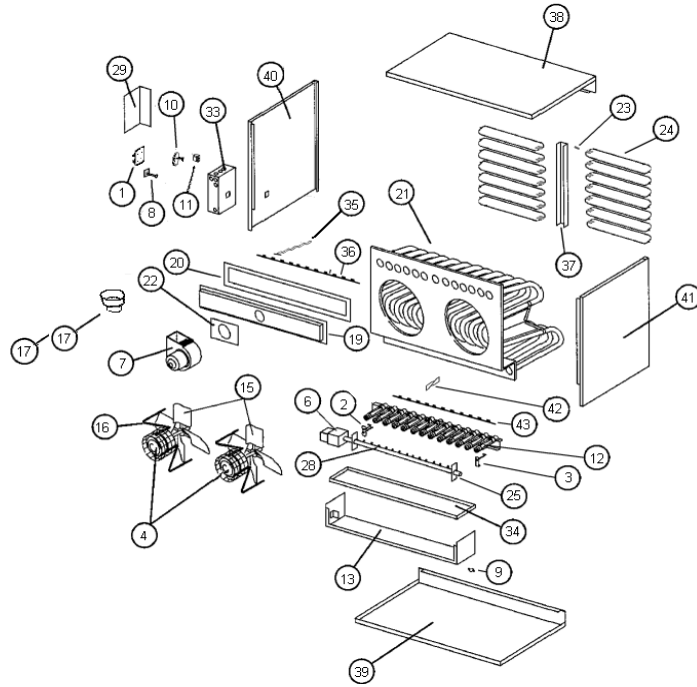

SEP UNIT HEATER SEP 175 - 290

DRAWING NUMBER	DESCRIPTION	PART NUMBER	SEP 175					SEP 200			SEP 230					SEP 250		SEP 290					
			1	2	3	4	5	1	2	3	1	2	3	4	5			1	2	3	4	5	
ALUMINIZED STEEL HEAT EXCHANGER			1	2	3	4	5	1	2	3	1	2	3	4	5			1	2	3	4	5	
STAINLESS STEEL HEAT EXCHANGER						0	1	1	2	3				0	1							0	1
1	CONTROL BOARD																						
		10000240	X								X							X					
		176777500			X			X				X								X			
		76722700				X			X				X	X								X	
2	ELECTRODE/SPARK IGNITER																						
		76714900		X				X			X			X			X					X	
3	ELECTRODE/FLAME SENSOR																						
		76715000		X				X			X			X			X					X	
4	FAN MOTOR (BLOWER MOTOR)																						
		76714500		X				X					2			2						2	
6	GAS VALVE (LP)																						
		76717500		X				X															
		176717600										X				X						X	
6	GAS VALVE (NAT)																						
		76714600		X				X															
		76714800										X				X						X	
28	ORIFICE (NAT)																						
	Straight thread	176712300		6								8								10			
	Tapered thread	76723000				6								8								10	
	Straight thread	176712200																					
	Tapered thread	76723700																					
	Straight thread	176712400						6															
	Tapered thread	76723400														10							
	Tapered thread	76723600								6													
28	ORIFICE (LP)																						
	Straight thread	176717200																					
	Tapered thread	76724000																					
	Tapered thread	176723500														10							
	Straight thread	76717300		6								8								10			
	Tapered thread	76723100				6								8								10	
	Straight thread	176717400						6															
	Tapered thread	176723300							6														

SEP UNIT HEATER SEP 175 - 290

DRAWING NUMBER	DESCRIPTION	PART NUMBER	SEP 175					SEP 200			SEP 230					SEP 250		SEP 290				
			1	2	3	4	5	1	2	3	1	2	3	4	5			1	2	3	4	5
	ALUMINIZED STEEL HEAT EXCHANGER																					
	STAINLESS STEEL HEAT EXCHANGER				0	1		1	2	3				0	1						0	1
7	INDUCED DRAFT MOTOR ASSEMBLY (includes motor, housing, & blower wheel)	76746100																				
		76714300A		X				X				X				X					X	
		76738400																				
		76714200																				
8	LIMIT SWITCH	176716600											X								X	
		76716400						X														
		176716700	X							X						X	X					
		176716500			X																	
9	AUXILIARY LIMIT (ROLLOUT)	176717100											X		X		X					
10	PRESSURE SWITCH	176776900		X				X				X									X	
		176777000													X							
		176777100																				
		176777200																				
		176777300																				
11	TRANSFORMER	76715500		X				X				X			X		X				X	
12	BURNER	76711200																				
		76711300			6			6				8			10					10		
15	FAN BLADE	176710700																				
		176776400		X				X				X			X						X	
16	FAN MOTOR MOUNT / GUARD	176711000																				
		176711100		X				X				2			2						2	
17	FLUE ADAPTER	1 76735000																				
		76708500																				
		76708600		X				X				X			X						X	
		76708700																				
19	FLUE BOX	176709100																				
		176709000																				
		176718900																				
		176709200																				
		176719100																				
		176709300																				
		176721300	X																			
		176709400		X																		
		176709500						X														
		176736600							X						X							
		176709600										X										
		176736700															X					
		176709700																			X	
		176709800																				
		176709900																				

SEP UNIT HEATER SEP 175 - 290

DRAWING NUMBER	DESCRIPTION	PART NUMBER	SEP 175					SEP 200			SEP 230					SEP 250		SEP 290										
			1	2	3	4	5	1	2	3	1	2	3	4	5			1	2	3	4	5						
	ALUMINIZED STEEL HEAT EXCHANGER																											
	STAINLESS STEEL HEAT EXCHANGER				0	1		1	2	3					0	1										0	1	
20	FLUE BOX GASKET																											
		176710000																										
		176710100																										
		176710200			X			X																				
		176710300											X			X								X				
22	INDUCED DRAFT MOTOR GASKET																											
		176708800																										
		176708900			X			X				X			X									X				
Not Shown	SILICONE TUBING																											
		176742001			X			X				X			X								X			X		
21	HEAT EXCHANGER (ALUMINIZED)																											
		176707300																										
		176707400																										
		176707500																										
		176707600																										
		176707700			X			X																				
		176707800											X															
		176707900														X								X				
		176708000																										
21	HEAT EXCHANGER (STAINLESS)																											
		176711400																										
		176711500																										
		176711600																										
		176711700																										
		176708100							X																			
		176708200												X														
		176711900														X											X	
		176708300																										
23	LOUVER SPRING																											
		76713500				7			7					14		14											14	
24	LOUVER VANE, BEIGE																											
		176713100																										
		176713200																										
		176713300				7			7																			
		176713400												14		14											14	
25	MANIFOLD																											
	* For these models, you also need to order tapered thread orifices. (All new manifolds have tapered threads and will not fit with older orifices having straight threads).	176724800																										
		176724700																										
		176724400																										
		176724500																										
		176724600			X *		X		X *	X																		
		176724100												X *		X												
		176724200															X							X *			X	
		176724300																										

SEP UNIT HEATER SEP 175 - 290

DRAWING NUMBER	DESCRIPTION	PART NUMBER	SEP 175					SEP 200			SEP 230					SEP 250		SEP 290					
			1	2	3	4	5	1	2	3	1	2	3	4	5			1	2	3	4	5	
ALUMINIZED STEEL HEAT EXCHANGER																							
STAINLESS STEEL HEAT EXCHANGER						0	1	1	2	3					0	1						0	1
29	CONTROL BOX COVER	176712600			X			X			X			X			X			X			
33	CONTROL BOX	176712500			X			X			X			X			X			X			
34	DRIP SHIELD	176712700																					
		176712800																					
		176712900			X			X															
		176713000											X			X				X			
35	FLUE BAFFLE	176710400			6			6					8			10			10				
36	FLUE BAFFLE BRACKET	176710500																					
		176710600			X			X					2			2			2				
37	LOUVER BRACKET	176714100											X			X			X				
38	PANEL, TOP	176701000																					
		176700900																					
		176701100			X																		
		176700800											X			X			X				
39	PANEL, BOTTOM	176701500																					
		176701300																					
		176701400			X			X															
		176701200											X			X			X				
40	PANEL, LEFT SIDE (viewed from r	176701900																					
		176702100			X			X															
		176702000											X			X			X				
41	PANEL, RIGHT SIDE (viewed from r	176701600																					
		176701800			X			X															
		176701800											X			X			X				
42	TURBULATOR FOR NOX	176717800			6			6					8			10			10				
43	TURBULATOR RETAINER	176717900			X			X					2			2			2				
Not Shown	FAN TIMER	100002477	X								X					X			X				
Not Shown	GAS PRESSURE SWITCH	76717700			X																		
Not Shown	IGNITION WIRE	100000546	X								X					X			X				
		76715100			X			X															
		76715200											X			X			X				
Not Shown	FLAME SENSOR WIRE	100000547	X								X					X			X				
		100000548											X						X				
		176738500				X		X															
		176738600													X	X						X	
Not Shown	WIRING HARNESS	176722900				X		X															
		176717000											X						X				
		176722800												X	X						X		

SEP

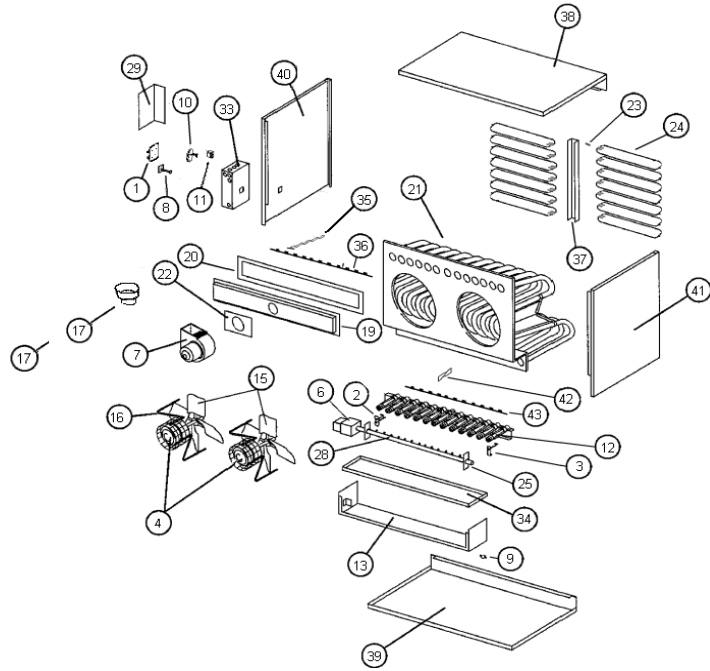

SEP UNIT HEATER SEP 300 - 400

DRAWING NUMBER	DESCRIPTION	PART NUMBER	SEP 300				SEP 345				SEP 400				
			1	2	3	4	5	6	1	2	3	4			
	ALUMINIZED STEEL HEAT EXCHANGER														
	STAINLESS STEEL HEAT EXCHANGER							0	1			1	2	3	4
1	CONTROL BOARD														
		10000240				X									
		176777500						X					X		
		76722700	X							X					X
2	ELECTRODE/SPARK IGNITER														
		76714900	X				X							X	
3	ELECTRODE/FLAME SENSOR														
		76715000	X				X							X	
4	FAN MOTOR (BLOWER MOTOR)														
		76714500		2				2						2	
6	GAS VALVE (LP)														
		76717500													
		176717600	X					X						X	
6	GAS VALVE (NAT)														
		76714600													
		76714800	X					X						X	
28	ORIFICE (NAT)														
	Straight thread	176712300					12								
	Tapered thread	76723000								12					
	Straight thread	176712200													
	Tapered thread	76723700													
	Straight thread	176712400											12		
	Tapered thread	76723400		12											
	Tapered thread	76723600													12
28	ORIFICE (LP)														
	Straight thread	176717200													
	Tapered thread	76724000													
	Tapered thread	176723500		12											
	Straight thread	76717300					12								
	Tapered thread	76723100								12					
	Straight thread	176717400											12		
	Tapered thread	176723300													12

SEP UNIT HEATER SEP 300 - 400

DRAWING NUMBER	DESCRIPTION	PART NUMBER	SEP 300	SEP 345				SEP 400					
				1	2	3	4	5	6	1	2	3	4
	ALUMINIZED STEEL HEAT EXCHANGER												
	STAINLESS STEEL HEAT EXCHANGER							0	1	1	2	3	4
7	INDUCED DRAFT MOTOR ASSEMBLY (includes motor, housing, & blower wheel)	76746100											
		76714300A	X										
		76738400				X					X		
		76714200											
8	LIMIT SWITCH	176716600				X							
		76716400											
		176716700	X								X		
		176716500											
9	AUXILIARY LIMIT (ROLLOUT)	176717100	X			X					X		
10	PRESSURE SWITCH	176776900	X			X							
		176777000									X		
		176777100											
		176777200											
		176777300											
11	TRANSFORMER	76715500	X			X					X		
12	BURNER	76711200											
		76711300	12			12					12		
15	FAN BLADE	176710700											
		176776400	X			X					X		
16	FAN MOTOR MOUNT / GUARD	176711000											
		176711100	2			2					2		
17	FLUE ADAPTER	1 76735000											
		76708500											
		76708600	X	X									
		76708700				X					X		
19	FLUE BOX	176709100											
		176709000											
		176718900											
		176709200											
		176719100											
		176709300											
		176721300											
		176709400											
		176709500											
		176736600											
		176709600											
		176736700											
		176709700	X										
		176709800				X							
		176709900									X		

SEP UNIT HEATER SEP 300 - 400

DRAWING NUMBER	DESCRIPTION	PART NUMBER	SEP 300	SEP 345						SEP 400				
				1	2	3	4	5	6	1	2	3	4	
	ALUMINIZED STEEL HEAT EXCHANGER													
	STAINLESS STEEL HEAT EXCHANGER							0	1	1	2	3	4	
20	FLUE BOX GASKET													
		176710000												
		176710100												
		176710200												
		176710300	X				X					X		
22	INDUCED DRAFT MOTOR GASKET													
		176708800												
		176708900	X				X					X		
Not Shown	SILICONE TUBING													
		176742001	X				X					X		
21	HEAT EXCHANGER (ALUMINIZED)													
		176707300												
		176707400												
		176707500												
		176707600												
		176707700												
		176707800												
		176707900												
		176708000	X				X					X		
21	HEAT EXCHANGER (STAINLESS)													
		176711400												
		176711500												
		176711600												
		176711700												
		176708100												
		176708200												
		176711900												
		176708300	X						X			X		
23	LOUVER SPRING													
		76713500	14				14					14		
24	LOUVER VANE, BEIGE													
		176713100												
		176713200												
		176713300												
		176713400	14				14					14		
25	MANIFOLD													
	* For these models, you also need to order tapered thread orifices. (All new manifolds have tapered threads and will not fit with older orifices having straight threads).	176724800												
		176724700												
		176724400												
		176724500												
		176724600												
		176724100												
		176724200												
		176724300	X				X*			X		X*		X

SEP UNIT HEATER SEP 300 - 400

DRAWING NUMBER	DESCRIPTION	PART NUMBER	SEP 300	SEP 345						SEP 400				
				1	2	3	4	5	6	1	2	3	4	
	ALUMINIZED STEEL HEAT EXCHANGER													
	STAINLESS STEEL HEAT EXCHANGER							0	1	1	2	3	4	
29	CONTROL BOX COVER	176712600	X				X					X		
33	CONTROL BOX	176712500	X				X					X		
34	DRIP SHIELD	176712700												
		176712800												
		176712900												
		176713000	X				X					X		
35	FLUE BAFFLE	176710400	12				12					12		
36	FLUE BAFFLE BRACKET	176710500												
		176710600	X				X					X		
37	LOUVER BRACKET	176714100	X				X					X		
38	PANEL, TOP	176701000												
		176700900												
		176701100												
		176700800	X				X					X		
39	PANEL, BOTTOM	176701500												
		176701300												
		176701400												
		176701200	X				X					X		
40	PANEL, LEFT SIDE (viewed from r	176701900												
		176702100												
		176702000	X				X					X		
41	PANEL, RIGHT SIDE (viewed from r	176701600												
		176701800												
		176701800	X				X					X		
42	TURBULATOR FOR NOX	176717800	12				12					12		
43	TURBULATOR RETAINER	176717900	2				2					2		
Not Shown	FAN TIMER	100002477					X							
Not Shown	GAS PRESSURE SWITCH	76717700												
Not Shown	IGNITION WIRE	100000546					X							
		76715100												
		76715200	X				X					X		
Not Shown	FLAME SENSOR WIRE	100000547												
		100000548					X							
		176738500												
		176738600	X							X				X
Not Shown	WIRING HARNESS	176722900												
		176717000					X					X		
		176722800	X							X				X

HED

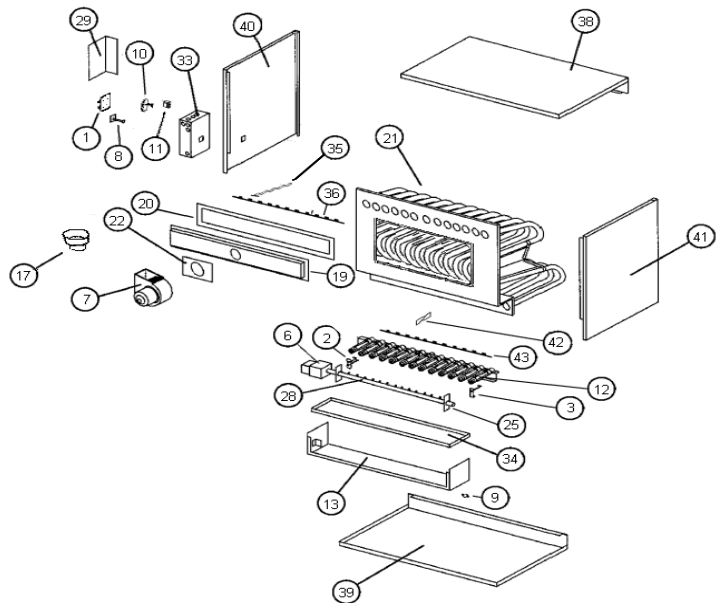

HED DUCT FURNACE HED 75 - 150

DRAWING NUMBER	DESCRIPTION	PART NUMBER	HED75			HED100			HED125			HED150		
			1	2	3	1	2	3	1	2	3	1	2	3
1	CONTROL BOARD													
		100000240	X			X			X			X		
		176777500		X			X			X			X	
		76722700			X			X			X			X
2	ELECTRODE/SPARK IGNITER													
		76714900		X			X			X			X	
3	ELECTRODE/FLAME SENSOR													
		76715000		X			X			X			X	
6	GAS VALVE (NAT)													
		76714600		X			X			X			X	
		76714800												
28	ORIFICE (NAT)													
	Straight thread	176719400		6										
	Tapered thread	176723900			6									
	Straight thread	176719500					4			5			6	
	Tapered thread	76723400						4			5			6
7	INDUCED DRAFT MOTOR ASSEMBLY (includes motor, housing, & blower wheel)													
		76746100		X			X			X			X	
		76714300A												
8	LIMIT SWITCH													
		176716600		X										
		76716400												
		176716700												
		176716500					X			X			X	
9	AUXILIARY LIMIT													
		176717100												
10	PRESSURE SWITCH													
		176777100		X										
		176722500					X						X	
		176722600								X				
		176776900												
11	TRANSFORMER													
		76715500		X			X			X			X	
12	BURNER													
		76711300					4			5			6	
		76711200		6										
17	FLUE ADAPTER													
		76708500		X			X			X			X	
		76708600												

HED DUCT FURNACE HED 75 - 150

DRAWING NUMBER	DESCRIPTION	PART NUMBER	HED75			HED100			HED125			HED150		
			1	2	3	1	2	3	1	2	3	1	2	3
19	FLUE BOX													
		176718900					X							
		176712100		X										
		176718800								X				
		176721400												
		176721500												
		176719100											X	
		176721300												
20	FLUE BOX GASKET													
		176710000		X										
		176710100					X			X				
		176710200											X	
		176710300												
21	HEAT EXCHANGER (ALUM)													
		176719700		X										
		176719800					X							
		176719900								X				
		176720000											X	
		176720100												
		176720200												
		176720300												
21	HEAT EXCHANGER (STAINLESS)													
		176720400		X										
		176720500					X							
		176720600								X				
		176720700											X	
		176720800												
		176720900												
		176721000												
22	INDUCED DRAFT GASKET													
		176708800		X			X			X			X	
		176708900												
25	MANIFOLD													
	* For these models, you also need to order tapered thread orifices. (All new manifolds have tapered threads and will not fit with older orifices having straight threads).	176724700		X *	X		X *	X						
		176724400					X *	X						
		176724500								X *	X			
		176724600											X *	X
		176724100												
		176724200												
		176724300												
29	CONTROL BOX COVER													
		176712600		X			X			X			X	
33	CONTROL BOX													
		176712500		X			X			X			X	
38	PANEL, TOP													
		176701000		X										
		176700900					X			X				
		176701100											X	
		176700800												
39	PANEL, BOTTOM													
		176701500		X										
		176701300					X			X				
		176701400											X	
		176701200												
40	PANEL, LEFT SIDE (as viewed from rear)													
		176701900		X										
		176702100					X			X			X	
		176702000												
41	PANEL, RIGHT SIDE (as viewed from rear)													
		176701600		X										
		176701800					X			X			X	
		176701700												
Not Shown	FAN TIMER													
		100002477	X			X			X			X		
Not Shown	IGNITION WIRE													
		100000546	X			X			X			X		
		76715100		X			X			X			X	
		76715200												
Not Shown	FLAME SENSOR WIRE													
		100000547	X			X			X			X		
		100000548												
		176738500			X			X			X			X
		176738600												

HED

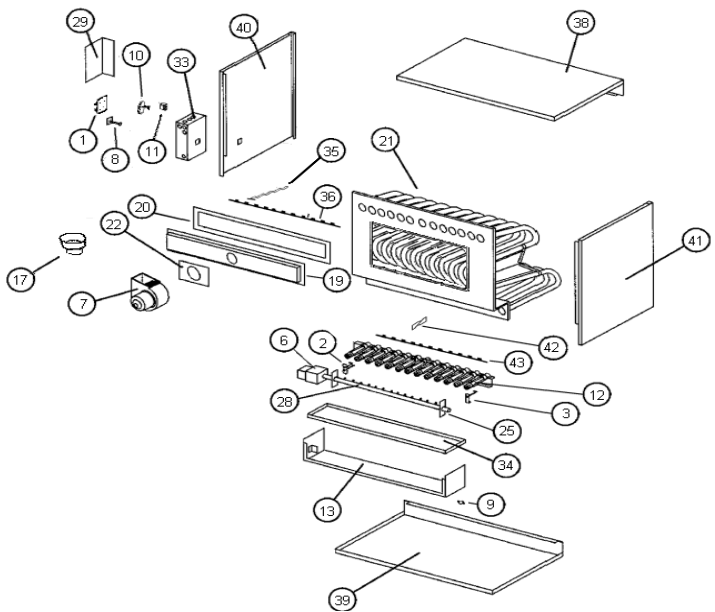

HED DUCT FURNACE HED 200 - 300

DRAWING NUMBER	DESCRIPTION	PART NUMBER	HED200			HED250			HED300		
			1	2	3	1	2	3	1	2	3
1	CONTROL BOARD	10000240	X			X			X		
		176777500		X			X			X	
		76722700			X			X			X
2	ELECTRODE/SPARK IGNITER	76714900		X			X			X	
3	ELECTRODE/FLAME SENSOR	76715000		X			X			X	
6	GAS VALVE (NAT)	76714600									
		76714800		X			X			X	
28	ORIFICE (NAT)	176719400									
		176723900									
		176719500		8			10			12	
		76723400			8			10			12
7	INDUCED DRAFT MOTOR ASSEMBLY (includes motor, housing, & blower wheel)	76746100									
		76714300A		X			X			X	
8	LIMIT SWITCH	176716600									
		76716400								X	
		176716700					X				
		176716500		X							
9	AUXILIARY LIMIT	176717100		X			X			X	
10	PRESSURE SWITCH	176777100									
		176722500									
		176722600									
		176776900		X			X				X
11	TRANSFORMER	76715500		X			X			X	
12	BURNER	76711300		8			10			12	
		76711200									
17	FLUE ADAPTER	76708500									
		76708600		X			X			X	

HED DUCT FURNACE HED 200 - 300

DRAWING NUMBER	DESCRIPTION	PART NUMBER	HED200			HED250			HED300		
			1	2	3	1	2	3	1	2	3
19	FLUE BOX										
		176718900									
		176712100									
		176718800									
		176721400					X				
		176721500								X	
		176719100									
		176721300		X							
20	FLUE BOX GASKET										
		176710000									
		176710100									
		176710200									
		176710300		X			X			X	
21	HEAT EXCHANGER (ALUM)										
		176719700									
		176719800									
		176719900									
		176720000									
		176720100		X							
		176720200					X				
		176720300								X	
21	HEAT EXCHANGER (STAINLESS)										
		176720400									
		176720500									
		176720600									
		176720700									
		176720800		X							
		176720900					X				
		176721000								X	
22	INDUCED DRAFT GASKET										
		176708800									
		176708900		X			X			X	
25	MANIFOLD										
	* For these models, you also need to order tapered thread orifices. (All new manifolds have tapered threads and will not fit with older orifices having straight threads).	176724700									
		176724400									
		176724500									
		176724600									
		176724100		X *	X						
		176724200					X *	X			
		176724300								X *	X
29	CONTROL BOX COVER										
		176712600		X			X			X	
33	CONTROL BOX										
		176712500		X			X			X	
38	PANEL, TOP										
		176701000									
		176700900									
		176701100									
		176700800		X			X			X	
39	PANEL, BOTTOM										
		176701500									
		176701300									
		176701400									
		176701200		X			X			X	
40	PANEL, LEFT SIDE (as viewed from rear)										
		176701900									
		176702100									
		176702000		X			X			X	
41	PANEL, RIGHT SIDE (as viewed from rear)										
		176701600									
		176701800									
		176701700		X			X			X	
Not Shown	FAN TIMER										
		100002477	X				X			X	
Not Shown	IGNITION WIRE										
		100000546	X				X			X	
		76715100									
		76715200		X			X			X	
Not Shown	FLAME SENSOR WIRE										
		100000547									
		100000548	X				X			X	
		176738500									
		176738600			X			X			X

FOA

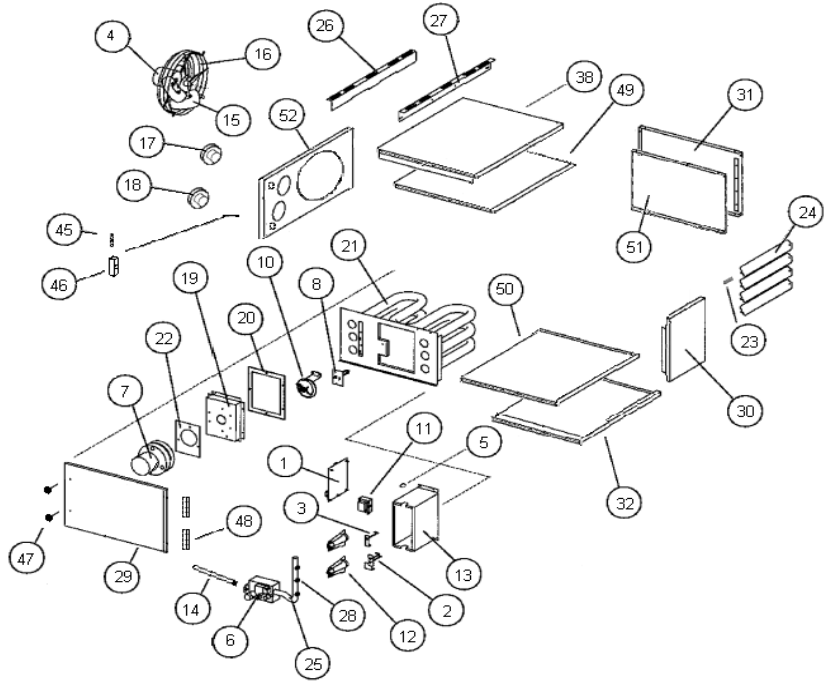

FOA UNIT HEATER

DRAWING NUMBER	DESCRIPTION	PART NUMBER	FOA 45	FOA 60	FOA 75	FOA 100	FOA 125	FOA 150	FOA 200	FOA 250	FOA 300
1	CONTROL BOARD	76722700					X				
	WIRE HARNESS 6-PIN	176722900					X				
45	24V TERMINAL BOARD	176700060					X				
	DOOR SWITCH	76729900A					X				
2	ELECTRODE/SPARK IGNITER	176700050					X				
	WIRE, IGNITION cable	76715100					X				
3	ELECTRODE/FLAME SENSOR	176700051					X				
	WIRE, FLAME SENSE	176738500					X				
4	FAN MOTOR (BLOWER MOTOR)	76791000	X								
		176700242		X	X	X	X			X	2
		76714500						X	X		
5	FLAME ROLLOUT SWITCH	176739900	1								
		176740200		2	2	1	1				
6	GAS VALVE (LP)	76717500				X					
		176700264									X
6	GAS VALVE (NAT)	76714600				X					
		176700265									X
28	ORIFICE (LP)	76724000	3	4	5						
		176723500				4	5	6		10	
		76723100							7		11

FOA UNIT HEATER

DRAWING NUMBER	DESCRIPTION	PART NUMBER	FOA 45	FOA 60	FOA 75	FOA 100	FOA 125	FOA 150	FOA 200	FOA 250	FOA 300
28	ORIFICE (NAT)	76723700	3	4							
		176700281			5						
		76723400				4	5				
		176700263						6			11
		76723600							7		
		76723400								10	
7	INDUCED DRAFT MOTOR ASSEMBLY (includes motor, housing, & blower wheel)	76739200	X	X	X						
		76714300A				X	X	X	X	X	X
8	LIMIT SWITCH	76739700	X	X	X						
		76716400				X	X	X	X		X
		176716500								X	
10	PRESSURE SWITCH	176777400	X	X							
		76777300			X						
		176722600				X					
		176700096					X				
		176776900						X	X		
		76777000								X	
		176700236									X
46	ELECTRICAL BOX	176700056						X			
Not Shown	ELECTRICAL BOX COVER	176700057						X			
11	TRANSFORMER	76715500						X			
12	BURNER INSHOT	76739500	3	4	5						
		76711300				4	5	6	7	10	11
13	BURNER BOX	176773700	X								
		176773800		X	X						
Not Shown	BURNER SUPPORT PLATE	176700272				X	X				
		176700237						X	X		
		176700239								X	X
Not Shown	BURNER BOX TOP	176700085	X								
		176700086		X							
		176700087			X						
15	FAN BLADE	176739100	X								
		176740000		X							
		176701184			X						
		176776400				X	X			X	X
		176700250						X	X		
16	FAN GUARD	176739000	X	X							
		176740100			X						
		176700059				X	X				
		176700249						X	X		
		176711100								X	2

FOA UNIT HEATER

DRAWING NUMBER	DESCRIPTION	PART NUMBER	FOA 45	FOA 60	FOA 75	FOA 100	FOA 125	FOA 150	FOA 200	FOA 250	FOA 300
17	INLET AIR ADAPTER	176700279	X								
		176700231						X			
Not Shown	INLET AIR ADAPTER GASKET	176700063	X								
		176700062						X			
18	FLUE ADAPTER	176735000	X								
		176737800		X	X						
		76708600				X	X	X	X	X	
		76708700									X
19	FLUE BOX	176700102	X								
		176700103		X							
		176700104			X						
		176700033				X					
		176700034					X				
		176700247						X			
		176700248							X		
		176700258								X	
		176700259									X
20	FLUE BOX GASKET	176739300	X								
		176740300		X	X						
		176700058				X	X				
		176700253						X	X		
		176700254								X	X
21	HEAT EXCHANGER ASSEMBLY	176700067	X								
		176700069		X							
		176700053				X					
		176700054					X				
		176700232						X			
		176700233							X		
		176700234								X	
		176700235									X
22	INDUCED DRAFT GASKET	176739300	X								
		176708800		X	X						
		176708900				X	X	X	X	X	X
54	INDUCED DRAFT MOTOR PLATE	176700105	X	X	X						
53	GASKET INDUCED DRAFT MOTOR PLATE	176700106	X	X	X						
23	LOUVER SPRING	76713500	4	6	6	6	6	8	8	12	12
24	LOUVER VANE (BEIGE)	176741100	4	6	6						
		176713100				6	6	8	8	12	12
25	MANIFOLD	176774000	X								
		176774100		X							
		176774200			X						
		176700046				X					
		176700280					X				
		176700251						X			
		176700252							X		
		176700261								X	
		176700262									X
14	MANIFOLD CONNECTION	176700048	X	X	X						
		176700040				X	X	X	X		
		176700230								X	X

FOA UNIT HEATER

DRAWING NUMBER	DESCRIPTION	PART NUMBER	FOA 45	FOA 60	FOA 75	FOA 100	FOA 125	FOA 150	FOA 200	FOA 250	FOA 300
Not Shown	MANIFOLD GROMMET	176700047	X	X	X	X	X	X	X		
		176700278								X	X
26	MOUNTING BRACKET, BACK	176750900	X	X	X						
27	MOUNTING BRACKET, FRONT	176750800	X	X	X						
30	FRONT PANEL	176700079	X								
		176700031		X	X						
		176700037				X	X				
		176700244						X	X		
		176700256								X	X
38	TOP PANEL	176700098	X	X	X						
		176700035				X	X	X	X	X	X
32	BOTTOM PANEL	176700099	X	X	X						
		176700229				X	X	X	X		
		176700241								X	X
50	TOP / BOTTOM INSULATING PANEL	176700070	X	X	X						
		176700282				X	X	X	X	X	X
31	SIDE PANEL	176700080	X								
		176700073		X	X						
		176700038				X	X				
		176700245						X	X		
		176700260								X	X
51	SIDE INSULATING PANEL	176700081	X								
		176700071		X	X						
		176700043				X	X				
		176700246						X	X		
		176700284								X	X
52	FAN PANEL	176700097	X								
		176700101		X	X						
		176700036				X	X				
		176700243						X	X		
		176700255								X	X
29	ACCESS DOOR	176700076	X								
		176700075		X	X						
		176700074				X	X				
		176700285						X	X		
		176700286								X	X
Not Shown	SIGHT GLASS	176700042					X				

UHRS

UHRS UNIT HEATER

DESCRIPTION	PART NUMBER	UHRS30	UHRS45	UHRS60	UHRS75	UHRS90	UHRS105
CONTROL BOARD	176701586	X	X	X	X	X	X
WIRING HARNESS	176792900	X	X				
	176793000			X	X		
	176793100					X	X
ELECTRODE/FLAME SENSOR	176701611	X					
ELECTRODE/SPARK IGNITER	176701587	X					
FAN MOTOR (BLOWER MOTOR)	176701588	X	X				
	176701612			X	X		
	176701590					X	X
FLAME ROLLOUT SWITCH	176700252	X					
	176701591		X			X	X
	176701592			X	X		
GAS VALVE (LP)	176701593	X	X	X	X	X	X
GAS VALVE (NAT)	176701594	X	X	X	X	X	X
ORIFICE (LP)	176701595	2	3	4	5	7	7
ORIFICE (NAT)	176701596	2	3	4	5	7	7
IGNITION LEAD	176701597	X	X	X	X	X	X
INDUCED DRAFT MOTOR ASSEMBLY (includes motor, housing, & blower wheel)	176701598	X*	X*	X	X	X	X
	176795005 *After Ser # 7120K10000	X*	X*				
LIMIT SWITCH	176701599	X	X	X			
	176701630				X		X
	176795004					X	
PRESSURE SWITCH	176701601	X	X	X			X
	176701602				X		
	176701603					X	
TRANSFORMER	176701604	X	X	X	X	X	X
FAN BLADE	176701605	X	X				
	176701606			X	X		
	176701607					X	X
FAN GUARD	176701608	X	X				
	176701609			X	X		
	176701610					X	X
LOUVER SPRING	176701613	X	X	X	X	X	X
LOUVER VANE	176793400	3	3	5	5	7	7
MOUNTING BRACKET	176700255	2	2	2	2	2	2

UHCM

UHCM UNIT HEATER

DESCRIPTION	PART NUMBER	UHCM 125	UHCM 150	UHCM 175	UHCM 200	UHCM 250	UHCM 300	UHCM 350	UHCM 400
CONTROL BOARD	176701586	X	X	X	X	X	X	X	X
WIRING HARNESS	176793500	X	X	X	X				
	176793600					X	X	X	X
ELECTRODE/SPARK IGNITER	176701615	X	X	X	X	X	X	X	X
ELECTRODE/FLAME SENSOR	176701616	X	X	X	X	X	X	X	X
IGNITION LEAD	176793700	X	X	X	X	X	X	X	X
FAN MOTOR (BLOWER MOTOR)	176701617	X	X			X	X		
	176701618			X	X			X	X
GAS VALVE (LP)	176701593	X	X	X	X				
	176701620					X	X	X	X
GAS VALVE (NAT)	176701594	X	X	X	X				
	176701622					X	X	X	X
ORIFICE (LP)	176701623	5	6	7	8				
	176701624					5	6	7	8
ORIFICE (NAT)	176701625	5	6	7	8				
	176701626					10	12	14	16
INDUCED DRAFT MOTOR ASSEMBLY (includes motor, housing, & blower wheel)	176701627	X	X	X	X				
	176701628					X	X	X	X
FLAME ROLLOUT SWITCH	176700251	X	X	X	X	X	X	X	X
LIMIT SWITCH	176701599	X	X	X					
	176701630				X				
	176701631					X	X	X	X
PRESSURE SWITCH	176701632	X							
	176701633		X	X					
	176701634				X	X			
	176701635						X		
	176701636							X	
TRANSFORMER	176701604	X	X	X	X	X	X	X	X
FAN GUARD	176701610	X	X			X	X		
	176701639			X	X			X	X
FLUE ADAPTER	176701585			X	X	X	X		
	176701647							X	X
LOUVER SPRING	176701613	X	X	X	X	X	X	X	X
LOUVER VANE	176794000	9	9			18	18		
	176794100			9	9				
	176794200							18	18
POWER/THERMO TERMINAL	176792800	X	X	X	X	X	X	X	X

FOA - VENTING GUIDELINES

	Model Size (1000s BTUH)	Termination Type	Flue		Inlet air		Approved Caps	
			Material	Size	Material	Size	Flue	Inlet air
			FOA Horizontal Commercial Applications	45	Two pipe	Single wall	3"	Single wall
Cat. III	Cat. III							
60, 75	Two pipe	Single wall		4"	Single wall	4"	Tee	Tee
		Cat. III					Cat. III	
100, 125	Two pipe	Single wall		5"	Single wall	4"	Tee	Tee
		Cat. III					Cat. III	
150,200,250	Two pipe	Single wall	5"	Single wall	4"	Tee	Tee	
		Cat. III				Cat. III		
300	Two pipe	Single wall	6"	Single wall	4"	Tee	Tee	
		Cat. III				Cat. III		
	Concentric	Not available						

	Model Size (1000s BTUH)	Termination Type	Flue		Inlet air		Approved Caps	
			Material	Size	Material	Size	Flue	Inlet air
			FOA Vertical Commercial Applications	45	Two Pipe	Single wall	3"	Single wall
Double Wall (B-1)								
60, 75	Two Pipe	Single wall		4"	Single wall	4"	Any UL approved caps	
		Double Wall (B-1)						
100, 125	Two Pipe	Single wall		5"	Single wall	4"	Any UL approved caps	
		Double Wall (B-1)						
150,200,250	Two Pipe	Single wall	5"	Single wall	4"	Any UL approved caps		
		Double Wall (B-1)						
300	Two Pipe	Single wall	6"	Single wall	4"	Any UL approved caps		
		Double Wall (B-1)						
	Concentric	not available						

FOA Horizontal Residential Applications	Model Size (1000s BTUH)	Termination Type	Flue		Inlet air		Approved Caps	
			Material	Size	Material	Size	Flue	Inlet air
			45	Two pipe	Cat. III	* 3"	Single wall	3"
60, 75	Two pipe	Cat. III	4"	Single wall	4"	Cat. III	Tee	
100, 125	Two pipe	Cat. III	5"	Single wall	4"	Cat. III	Tee	

FOA Vertical Residential Applications	Model Size (1000s BTUH)	Termination Type	Flue		Inlet air		Approved Caps	
			Material	Size	Material	Size	Flue	Inlet air
			45	Two Pipe	Double Wall (B-1)	3"	Single wall	3"
Concentric	Double Wall (B-1)	* 3"			Single wall	* 3"	Concentric vent kit (4"/7")	
60, 75	Two Pipe	Double Wall (B-1)	4"	Single wall	4"	Any UL approved caps		
		Concentric	Double Wall (B-1)	4"	Single wall	4"	Concentric vent kit (4"/7")	
100, 125	Two Pipe	Double Wall (B-1)	5"	Single wall	4"	Any UL approved caps		
		Concentric	Double Wall (B-1)	5"	Single wall	** 4"	Concentric vent kit (5"/8")	

* Field supplied 3" to 4" increaser required for connection to concentric adapter

** Field supplied 4" to 5" increaser required for connection to concentric adapter

Note: Vent cap (for two pipe venting systems) 2 required per system

SEP, UHCM, HED - VENTING GUIDELINES

SEP, UHCM & HED Commercial Applications Only *	Model Size (1000s BTUH)	Horizontal Venting			Vertical Venting		
		Material	Size	Approved Caps	Material	Size	Approved Caps
	75 - 150	Single wall	4"	Tee	Single wall	4"	Any UL approved caps
Cat. III		Cat. III		Double Wall (B-1)			
175 - 300	Single wall	5"	Tee	Single wall	5"	Any UL approved caps	
	Cat. III		Cat. III	Double Wall (B-1)			
345 - 400	Single wall	6"	Tee	Single wall	6"	Any UL approved caps	
	Cat. III		Cat. III	Double Wall (B-1)			

* SEP and HED unit heaters are not approved for residential applications.

FSA, UHRS - VENTING GUIDELINES

FSA, UHRS Commercial Applications	Model Size (1000s BTUH)	Horizontal Venting			Vertical Venting		
		Material	Size	Approved Caps	Material	Size	Approved Caps
	30, 45	Single wall	3"	Tee	Single wall	3"	Any UL approved caps
Cat. III		Cat. III		Double Wall (B-1)			
60, 75	Single wall	4"	Tee	Single wall	4"	Any UL approved caps	
	Cat. III		Cat. III	Double Wall (B-1)			

FSA, UHRS Residential Applications	Model Size (1000s BTUH)	Horizontal Venting			Vertical Venting		
		Material	Size	Approved Caps	Material	Size	Approved Caps
	30, 45	Cat. III	3"	Cat. III	Double Wall (B-1)	3"	Any UL approved caps
60, 75	Cat. III	4"	Cat. III	Double Wall (B-1)	4"	Any UL approved caps	

LP FUEL CONVERSION KITS

LP Conversion Kit Part # (not available for SEP 60, 90)	Used On Models	Includes	Ship Weight
165296401	SEP 100	1 Honeywell Spring Kit, 1 Spring Kit, 6 #52 Tapered Orifices, 1 LP Pressure Switch, 1 A-Nipple LP Pressure Switch, 1 Elbow-LP Pressure Switch, 1 B-Nipple LP Pressure Switch, 6 Turbulators	2 lbs.
165295202	SEP 115, 145 & 175	1 393691 Honeywell Spring Kit, 1 92-0836 White Rogers Spring Kit, 6 #52 Tapered Orifices (Part # 76723100), 1 LP Pressure Switch, 1 A-Nipple LP Pressure Switch, 1 Elbow-LP Pressure Switch, 1 B-Nipple LP Pressure Switch, 6 Turbulators, 6 Turbulator Clips	2 lbs.
165295203	SEP 230, 290 & 345	1 LP Gas Valve (Part # 76717600), 12 #52 Tapered Orifices (Part # 76723100), 12 Turbulators, 12 Turbulator Clips	3 lbs.
165295205	SEP-200	1 393691 Honeywell Spring Kit, 1 92-0836 White Rogers Spring Kit, 6 .068 Tapered Orifices (Part # 76723300)	2 lbs.
165296403	SEP-250, 300	1 LP Gas Valve (Part # 76717600), 12 #53 Tapered Orifices (Part # 76723500), 12 Turbulators, 12 Turbulator Clips	3 lbs.
165295206	SEP-400	1 LP Gas Valve (Part # 76717600), 12 Tapered Orifices (Part # 76723300)	2 lbs.
165295204	CUH/FSA (all models)	1 393691 Honeywell Spring Kit (Part # 76757900), 1 92-0836 White Rogers Spring Kit (Part # 76757900), 1 Robert Shaw Spring Kit (Part #76768500), 5 #56 Tapered Orifices (Part # 76724000)	2 lbs.
165296405	FOA 45, 60 & 75	5 #56 Orifices (Part # 76724000), 1 White Rogers Spring Kit (Part # 76759100)	2 lbs.
165336303	FOA 100, 125, 150, 250	10 #53 Orifices (Part #76723500), 1 Honeywell Spring Kit (Part # 76759100)	2 lbs.
165336304	FOA 200 & 300	11 # 52 Orifices (Part # 76723100), 1 Honeywell Spring Kit (Part #76759100)	2 lbs.

LP Kits are not designed for and should not be used on HED duct furnaces.

LP & NG Kits have tapered thread orifices and will not fit older models with straight threads.

NG FUEL CONVERSION KITS & MOUNTING BRACKETS

NG Conversion Kit Part # (not available for SEP 90, 100, 250, 300, and CUH units)	Used On Models	Includes	Ship Weight
Kit not yet available. Components are listed at right.	SEP 100	6 Tapered Orifices (Part # 76723400), 1 Natural Gas Valve (Part # 76714600)	TBD
160000001	SEP 115, 145, 175	6 Tapered Orifices (Part # 76723000), 1 Natural Gas Valve (Part # 76714600)	2 lbs.
160000002	SEP 200	7 Tapered Orifices (Part # 76723600), 1 Natural Gas Valve (Part # 76714600)	2 lbs.
160000003	SEP 230, 290, 345	12 Tapered Orifices (Part # 76723000), 1 Natural Gas Valve (Part # 76714800)	2 lbs.
Kit not yet available. Components are listed at right.	SEP 250, 300	12 Tapered Orifices (Part # 76723400), 1 Natural Gas Valve (Part # 76714800)	TBD
160000004	SEP 400	12 Tapered Orifices (Part # 76723300), 1 Natural Gas Valve (Part # 76714800)	2 lbs.

LP & NG Kits have tapered thread orifices and will not fit older models with straight threads.

Description	Part #	Used On Models	Ship Weight
Mounting Bracket Kit	100001381	SEP 230 thru SEP400 and HED 200 thru 300 models	9 lbs.

UHRS & UHCM

FUEL CONVERSION KITS

LP Kits

Description	Kit Part #	Altitudes		Used On Models
		US	CANADA	
LP Conversion Kit	176701643	0 - 5,000ft	0 - 7,500ft	UHRS
LP High Altitude Conversion Kit	176795200	5,000 - 8,000ft	n/a	
LP High Altitude Conversion Kit	176795300	8,000 - 10,000ft	0 - 7,500ft	
LP High Altitude Conversion Kit	176795400	n/a	7,501 - 9,500ft	
LP Conversion Kit	176701641	0 - 5,000ft	0 - 7,500ft	UHCM 125 - 200
LP High Altitude Conversion Kit	176795500	5,000 - 9,000ft	7,501 - 9,500ft	
LP High Altitude Conversion Kit	176795600	9,001 - 10,000ft	n/a	
LP Conversion Kit	176794300	0 - 3,000ft	0 - 4,500ft	UHCM 250- 400
LP High Altitude Conversion Kit	176794400	3,001 - 5,000ft	4,501 - 7,500ft	
LP High Altitude Conversion Kit	176794500	5,001 - 7,000ft	7,501 - 9000ft	
LP High Altitude Conversion Kit	176794600	7,001 - 9,000	n/a	
LP High Altitude Conversion Kit	176794700	9,001 - 10,000	n/a	

Natural Gas Kits

Description	Kit Part #	Altitudes		Used On Models
		US	CANADA	
NG Conversion Kit	176701644	0 - 5,000ft	0 - 7,500ft	UHRS (All Models)
NG High Altitude Conversion Kit	176795700	5,000 - 7,000ft	7,501 - 9,500ft	
NG High Altitude Conversion Kit	176795800	7,000 - 10,000ft	n/a	
NG Conversion Kit	176701645			UHCM 125 - 200
NG High Altitude Conversion Kit	176795900	4,000 - 8,000	6,501 - 7,500ft	
NG High Altitude Conversion Kit	176796000	8,000 - 10,000	n/a	
NG Conversion Kit	176794800	0 - 5,000ft	0 - 7,500ft	UHCM 250 - 400
NG High Altitude Conversion Kit	176794900	5,000 - 8,000	7,501 - 9,500ft	
NG High Altitude Conversion Kit	176795100	8,000 - 10,000	n/a	



2175 West Park Place Boulevard
 Stone Mountain, GA 30087
www.adpnow.com