

Location: \_\_\_\_\_



**Lil-OS**

**Lil Max® – 10 to 50 GPM  
HDPE Oil / Sediment Interceptors**

**Specification:** MIFAB® Series Lil-(specify size)-OS HDPE injection molded oil / sediment interceptor with liquid holding capacity of \_\_\_\_\_ (indicate). Unit shall include: sediment bucket (1/4" diameter holes) underneath top inlet ductile iron grate(s), deep seal trap. For indoor/outdoor use.

**Function:** Oil / sediment interceptors are required anywhere oil and sediment may be introduced to the public sewer system in applications such as: repair garages, oil change stations, car wash facilities, parking garages and facilities where oil and flammable liquid waste are produced as a result of manufacturing, storage, maintenance, repair or testing processes. Sediment and debris are collected inside of the internal sediment bucket. Regular maintenance is required to keep the interceptor functioning. Interceptor to be installed flush with the floor. Standard Lil-OS models are made with open top ductile iron grate(s). The optional -SI models are made with a no hub inlet.



**Ductile Iron Grate(s). Load Class C (T2000-PGC-4). 19.5" L x 11" W x 1.44" H**

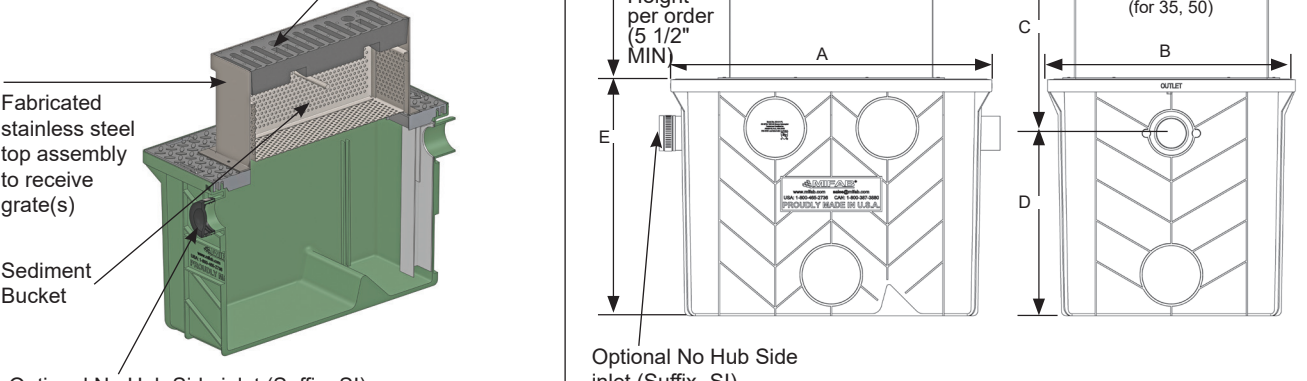

MODEL NO.	Liquid Holding Capacity (Gallons)	SLUDGE CAPACITY (L.B.S.)	A (IN)	B (IN) WIDTH	D (IN)	E (IN)	F (IN) (OUTLET)	Number of Grates	Shipping Weight (lbs.)
Lil-10-OS	8.5	15	23	17.5	9.75	13.25	2	1	50
Lil-15-OS	13	20	23	17.5	13.25	16.75	2	1	53
Lil-20-OS	16	25	29.5	20.5	10.75	14.25	3	1	61
Lil-25-OS	23	60	29.5	20.5	14.75	18.25	3	1	64
Lil-35-OS	39	80	33	25.5	16.75	22.25	3	2	77
Lil-50-OS	52	90	33	25.5	18.75	24.25	3	2	91

Suffix	Description
-3	Stainless steel veneer bolted to top of ductile iron grate(s)
-C	Extension "C" as required (in addition to the 5 1/2" provided) (for models Lil-10-OS to Lil-25-OS)
-C	Extension "C" as required (in addition to the 5 1/2" provided) (for models Lil-35-OS and Lil-50-OS)
-F	Connection sizes different from standard (specify size) (by using a MIFAB MI-HUB increasing / reducing coupling).
-FSCR	Stainless steel fine screen sediment bucket for Lil-10-OS through to Lil-25-OS
-FSCR	Stainless steel fine screen sediment bucket for Lil-35-OS and Lil-50-OS
-HLA	High level alarm and float switch (to be installed on site)
-LHSI	No hub inlet on left hand side (not available with sediment bucket)
-RHSI	No hub inlet on right hand side
-SI	No hub side inlet located on opposite side of outlet
-SP-IN	External Sampling Port - inline (part # Lil-SP)
-SP-OF	External Sampling Port - offset (part # Lil-SP-OF)
-T	Female threaded connections

CALIFORNIA PROPOSITION 65 WARNING. This product contains chemicals known to the State of California to cause cancer and birth defects or other reproductive harm.

Job Name: \_\_\_\_\_ Page No: \_\_\_\_\_  
 Section No: \_\_\_\_\_ Contractor: \_\_\_\_\_  
 Schedule No: \_\_\_\_\_ Purchase Order No: \_\_\_\_\_