

NO.	ALTERATIONS	DATE	BY	CHK'D

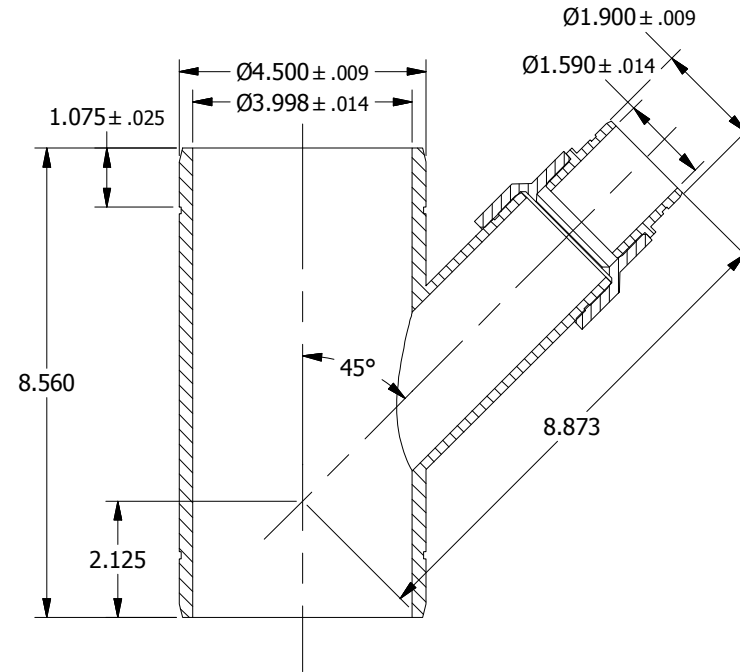
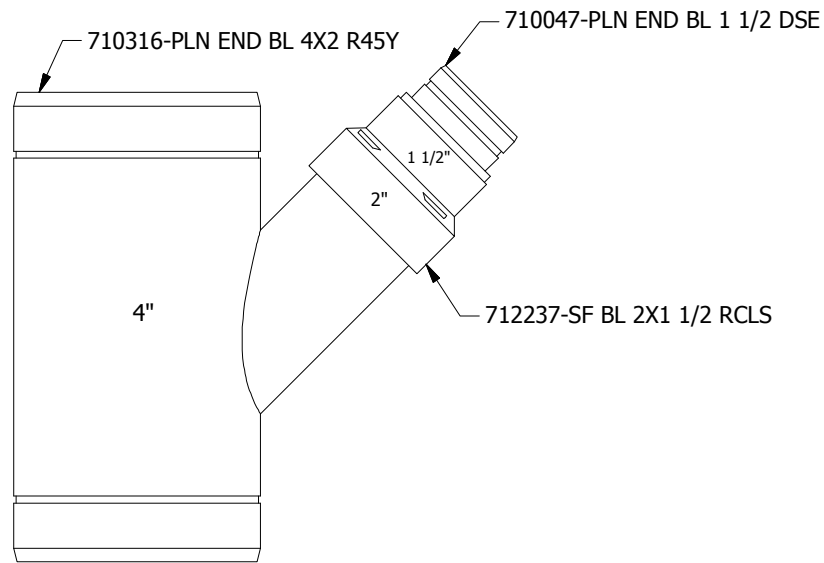

NOTES:

- 1.- THE MOLDED PART MUST BE FREE OF BURRS & FLASH
- 2.- THE SIZE OF THE PIECE MUST BE MARKED
- 3.- THE POSITION ON THE DRAWING OF THE SIZE MARKING IS FOR REFERENCE ONLY
- 4.- PLACE LABEL 92667291 ON THE PART

UNLESS OTHERWISE SPECIFIED DIMENSIONS ARE IN INCHES
TOLERANCES ARE IN:

DECIMALS	ANGLES	O-O-R
.XX= ±0.010	±0.5°	0.060
.XXX= ±0.005		

EDP. NO.	710345	WATTS BURLINGTON, ONTARIO, CANADA	ORION FITTINGS KANSAS CITY, KS 66115, USA	PART NO.	-
DWG. NO.	-	TITLE PLN END BL 4X1 1/2 R45Y			
REV	0	MATERIAL		WEIGHT	1.213 LB
PLOT	NTS	703000 VIRGIN 7823/TI4007 PPII 95%		BY	DRAWN
SCALE	1:1	706006 FLAME RETARDANT BLUE 5%		NAME	VASIM
COLOR	BLUE			DATE	16/9/15
		MATERIAL PPII		PRINTS BEFORE	SEP 16, 2015
				ARE VOID	