



4" Submersible Series

DEPENDABLE OPTIONS FOR ALL APPLICATIONS



BR4INGBB R1

 **GOULDS**
WATER TECHNOLOGY
a xylem brand

Residential Water Systems

A leader in the residential water industry, Goulds Water Technology has provided reliable, quality products for over 165 years.

Only sold through the professional channel, dealers have trusted Goulds Water Technology with the toughest installations.

With one of the broadest range of products, Goulds Water Technology offers efficient, dependable options for all applications.





PRODUCT LINE OVERVIEW

Performance Ranges

1 - 120 GPM • ½ to 10 HP

Trusted CentriPro Motor

2 and 3-wire NEMA Standard all stainless water-filled motor, tested in the toughest conditions

100% Performance Tested

Trusted performance out of the box

Smart Label

Pump and Motor part numbers
Serial Numbers
Assembly Date and Time
Performance Test Data

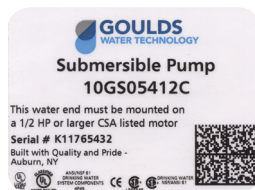

Materials of Construction

	Series		
	HS	G	GS
Check Valve Type	Composite	Composite	Stainless
Discharge Head	Composite	Stainless	Stainless
Motor Adapter	Composite	Stainless	Stainless
Diffuser	Lexan	Lexan	Lexan
Bowl	Stainless	Stainless	Stainless
Impeller	Noryl	Noryl	Noryl
Strainer	Composite	Composite	Stainless
Hex Shaft	304SS	304SS	304SS/17-4Ph
Casing	Stainless	Stainless	Stainless
Cable Guard	Composite	Composite	Stainless
Bearing	Engineered Polymer	Engineered Polymer	Engineered Polymer

FEATURES

	HS	G	GS
GUARDIAN System	N	N	Y
QUAD-LOCK Technology	Y	N	N
Trimline (Reduced Diameter)	N	Y	N
High Capacity Models Available	N	N	Y
50 Hz/60 Hz	Y	N	Y
Floating Stack	Y	Y	Y
Repairable	N	Y	Y
Agency Listings	CSA/CUS	CSA/CUS	CSA/CUS
NSF61 Certification	Y	Y	Y
VFD Capatible	Y	Y	Y
Lead Free	Y	Y	Y
Built in USA	Y	Y	Y
Performance Tested	Y	Y	Y
Smart Label	Y	Y	Y
Warranty	42/66 months	42/66 months	42/66 months



GWT EXCLUSIVE AND PROVEN FLOATING STACK HYDRAULIC DESIGN

Proven for over 5 decades with the most reliable sand handling and abrasion resistance.

Benefits of Floating Stack:

- Rotating components are not in contact therefore parts will not wear resulting in extended life and sustained performance over time.
- Allows sand and abrasives to pass easily
- Can run dry without wear or damage to the pump

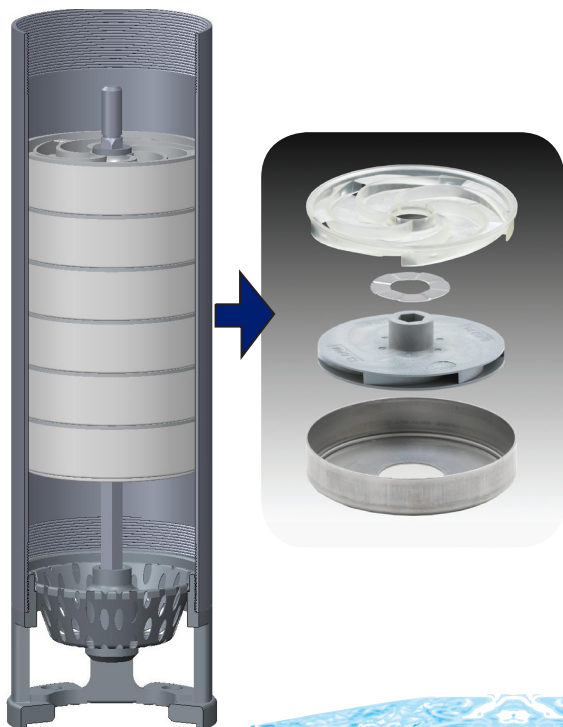

Noryl Impeller:

Reliable polymer material to overcome abrasion damage

Dual Surface Up Thrust Washer:

Prevents rubbing of components during up thrust

Lexan Diffuser:

High Abrasion resistance for longer life in harsh applications

AISI 304SS Stainless Steel Bowl:

Provides maximum corrosion resistance for longevity

GS SERIES

Stainless Steel Discharge Head

for maximum corrosion resistance featuring longer thread engagement for strength and improved serviceability.

Floating Stack Hydraulic:

proven for over 5 decades

Stainless Steel Strainer

for maximum corrosion resistance and prevents debris from entering pump.

Stainless Steel Motor Adapter

for maximum corrosion resistance

Dual Safety Loops: helps ease the installation of a safety cable without interfering with motor leads

Premium Quality Stainless Steel Internal Check Valve: helps minimize water loss

The Guardian® System

Includes an engineered polymer bearing which is resistant to damage from sand, abrasives and over-pumping a well.

Years of field-proven reliability and durability in some of the world's toughest submersible pump applications.

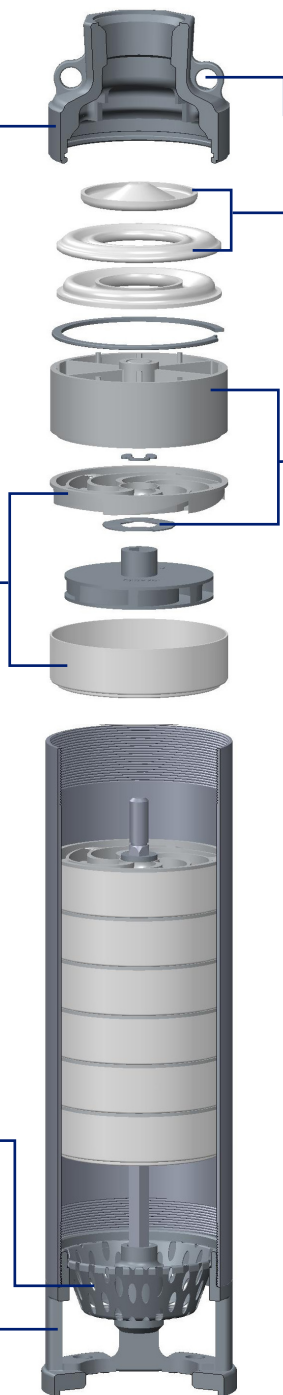

GS HIGH CAPACITY – GS EXTREME SERIES

BOTH FEATURE THE GUARDIAN® SYSTEM AND PROVEN INTERNAL COMPONENTS OF THE GS SERIES



GS High Capacity

Designed for residential, small municipal water supply as well as light irrigation applications.

Performance Ranges

- 1-10 HP
- 10-120 GPM
- Head up to 1250 feet
- Field serviceable
- 2" NPT discharge to accommodate higher flows



GS Xtreme™

Designed for extreme sand handling and coal bed methane extraction. This series is the deepest set within the Goulds Water Technology's submersible services.

Performance Ranges

- ½-10 HP
- 1-100 GPM
- Welded casing joints for Xtreme strength
- Features **upthrust limiter** to prevent damage due to upthrust
- Engineered polymer bearing for strength abrasion heat resistance
- Optional GWT Xtreme Duty motor is rated for continuous duty in 86°F water. Features silicon carbide mechanical seal and diaphragm filter to help prevent sand/debris entry.



Upthrust Limiter

HS SERIES

Check Valve:
Easily replaceable
without disassembly

**Engineered Composite
Discharge Head**
for corrosion resistance
and strength

Floating Stack Hydraulic:
proven for over 5 decades

**Engineered Composite
Motor Adapter** for
corrosion resistance and
strength, featuring wrap
around suction strainer.

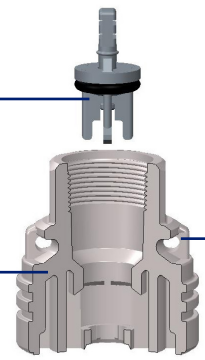

Dual Safety Loops:
helps ease the installation of a safety
cable without interfering with motor leads

Engineered Composite Bearing:
for improved abrasion resistance

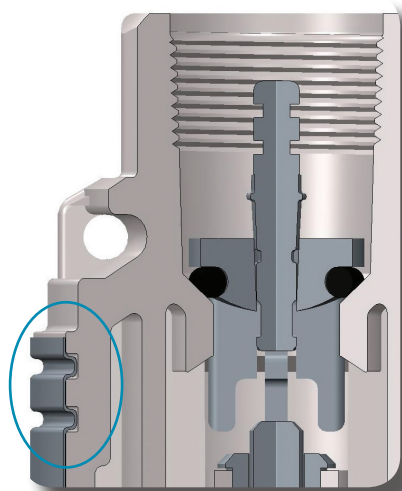
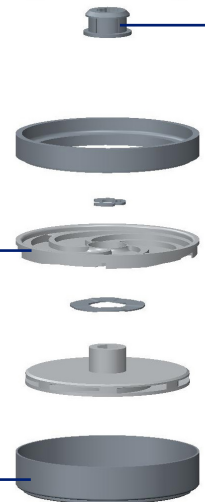

QUAD LOCK TECHNOLOGY

4 roll formed grooves provides one of the strongest connection available

Provides the durability and sealing needed in the toughest conditions

Tensile strength tested to exceed strength of poly and PVC Pipe





ABOUT GOULDS WATER TECHNOLOGY

Goulds Water Technology, a Xylem brand, is one of the world's leading brands in residential and commercial water products. The brand began in 1848 in Seneca Falls, NY, when Seabury S. Gould purchased a pump making business. Today, Xylem's Goulds Water Technology brand is a leader of residential, commercial and agricultural products globally.

For more information on residential water products and applications, visit <http://residential.goulds.com/>

OTHER GWT PRODUCTS INCLUDE:

4" Submersibles

Centripro Pumps, Motors and Controls

Jet Pumps

Centrifugal Pumps

Turbine Pumps

Water Tanks

Booster Pumps

Sump Pumps

Sewage Pumps

Effluent Pumps



Xylem Inc.
2881 East Bayard Street Ext., Suite A
Seneca Falls, NY 13148
Phone: (866) 325-4210
Fax: (888) 322-5877
www.gouldswatertechnology.com

Goulds is a registered trademark of Goulds Pumps, Inc. and is used under license.
© 2018 Xylem Inc. BR4INGBB R1 January 2018