

Vaddio™ WallVIEW™ CCU HD-18

High-Definition PTZ Camera featuring the Quick-Connect CCU and EZIM CCU



Model Number 999-6907-000 (North America)
Model Number 999-6907-001 (International)

Model Number 999-6907-000W (North America)
Model Number 999-6907-001W (International)
Arctic White Version



EZIM CCU Card for HD-18



Quick-Connect CCU for HD-18



WallVIEW CCU HD-18 Overview



With the WallVIEW CCU HD-18 PTZ camera and CAT-5 cabling system, Vaddio delivers a solution that allows for easy installation and integration. The camera is built around a 1.3 megapixel, 1/3" CCD with an 18x optical zoom lens, making it the ideal choice for a wide range of high definition video applications. In addition to the component HD output (720p, 1080i or 1080p), the camera comes with a simultaneous composite SD output (NTSC or PAL).

Because the camera module is built around a CCD image sensor, the HD-18 is excellent in low-light situations, with a 1.8 lux rating. In addition, the video signal to noise ratio output of the camera is greater than 50dB, delivering clean, clear video.

The multi-element Wide Dynamic Zoom lens allows WallVIEW CCU HD-18 to capture a wide angle of view (55.2°) enough to view everyone at a conference room table, as well as capture an individual from a long distance (3.2°). The zoom range provides greater flexibility for a wide variety of applications. Pan range is +170 to -170 degrees, and Tilt range is -30 to +90 degrees.

Paired with the HD-18 camera is Vaddio's Quick-Connect CCU breakout box. Installed at the equipment headend, the Quick-Connect CCU provides power, video and control up to 500 feet over three (3) CAT-5 cables. The CCU allows users to control a variety of image controls built into the camera, including iris, red and blue gain, pedestal, knee, gamma, chroma and gain.

The WallVIEW CCU HD-18 is an exceptional camera system for integration projects, since no power supply is required at the camera location. Use the WallVIEW CCU HD-18 for high definition camera applications, such as houses of worship, corporate boardrooms, live event production and distance-learning.

Intended Use:

Before operating the Vaddio WallVIEW CCU HD-18, please read the entire manual thoroughly. The system was designed, built and tested for use indoors, and with the provided power supply and cabling. The use of a power supply other than the one provided or outdoor operation has not been tested and could damage the camera and/or create a potentially unsafe operating condition.

Important Safeguards:

Read and understand all instructions before using. Do not operate any device if it has been dropped or damaged. In this case, a Vaddio technician must examine the product before operating. To reduce the risk of electric shock, do not immerse in water or other liquids and avoid extremely humid conditions.



Use only the power supply provided with the WallVIEW CCU HD-18 system. Use of any unauthorized power supply will void any and all

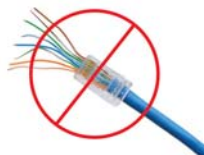

Do not use "pass-thru" RJ-45 connectors. Use standard RJ-45 connectors for best results.

Save These Instructions:

The information contained in this manual will help you install and operate your Vaddio WallVIEW CCU HD-18. If these instructions are misplaced, Vaddio keeps copies of Specifications, Installation and User Guides and most pertinent product drawings for the Vaddio product line on the Vaddio website. These documents can be downloaded from www.vaddio.com free of charge.

UNPACKING:

Carefully remove the device and all of the parts from the packaging.

Unpack and identify the following parts:

- One (1) ClearVIEW HD-18 PTZ Camera
- One (1) Quick-Connect CCU breakout box
- One (1) IR Remote Control
- One (1) EZIM CCU Card
- One (1) Wall Mount and Hardware
- One (1) RJ-45 to DB-9 Adapter
- One (1) Vaddio PowerRite 36 VDC, 2.78 Amp Power Supply
- One (1) AC Cord Set (US – North America or UK and Europe - International)
- Documentation and Manuals

Figure 1: ClearVIEW HD-18 PTZ Camera (front)



1. Camera – A 1/3", 1.3 megapixel HD image sensor is combined with an 18x optical zoom lens, for capturing high-quality video.
2. Tally Light – A tally light is illuminated when the camera receives a VISCA command or from the CCU tally port on the back of the Quick-Connect CCU.
3. IR Sensors – Dual IR sensors are built into the front of the WallVIEW CCU HD-18 to receive IR signals from the IR remote control supplied with the camera.
4. Power Light – A power light is illuminated when the camera is turned on.

Compatible Switchers and Joystick Controllers:

ProductionVIEW HD
(999-5600-000)



ControlVIEW XHD
(999-5672-000)



Precision Camera Controller
(999-5700-000)

Figure 3: WallVIEW CCU HD-18 camera (back)



5. RS-232 In & IR Out – The RS-232 accepts modified VISCA™ protocol for camera control, as well as transmits IR signaling received by the IR receivers, which can be transmitted to third party devices.
6. DIP Switch Settings – Settings for IR remote, baud rate, SD output format, image flip can be configured on these switches. See page 7 for additional information switch settings.
7. HD Video Select – A rotary switch allows the user to choose the component HD output video resolution and format. See page 7 for additional information on switch settings.
8. 12 VDC Input – NOTE: The power input is not used with the WallVIEW CCU HD-18 system. This is only used on the standard, ClearVIEW HD-18 camera.
9. YPbPr Video Output – Component HD video is fed through the DB-15 connector.
10. SD Video Output – Standard definition video is fed through the BNC connector.
11. EZ Port – CAT-5 cable (up to 100 feet) is connected to the Quick-Connect SR. The EZ-Port supplies power to the camera and delivers component HD video up to 100 feet.
12. EZIM CCU Card – Slot card for sending power (36 VDC) to the HD-18 camera and delivering video to the Quick-Connect CCU through the card in the back of the camera base.

Quick-Connect CCU Front Panel Controls (left to right):



Tally Light:

The blue LED tally light on the front panel is tied to the tally contacts on the rear panel allowing the user to easily track which camera interface is being used in a multi-camera system by supplying a simple contact closure (i.e. from ProductionVIEW Super Joystick or ProductionVIEW HD).

LCD Display:

Backlit (blue) display indicates which parameter (iris, detail, etc.) is being adjusted. When a rotary encoder is moved, the name of the control being actuated and the value of that assigned parameter will be displayed.

Scenes A, B & C:

Three camera adjustment scenes (A, B & C) can be stored into microprocessor memory. When lit (backlit blue SPDT switch), the scene is activated. To store a scene, the user adjusts the controls and touches and holds the scene button down until the button blinks.

Detail:

The Detail control sharpens or softens objects in the frame.

Red & Blue Gain Controls:

The Red and Blue Gain encoders adjust the red and blue gain of the signal when AWB is disengaged.

AWB:

The Automatic White Balance controls/adjusts the color levels automatically when engaged. Turn off AWB to manually adjust the Red and Blue levels, as well as Red, Green and Blue Enhance.

SHIFT:

Pressing Shift illuminates the button and changes the Pedestal adjustment knob to Knee adjustment. Knee adjustment allows a bright objects that are easily overexposed to be reproduced more accurately. Pressing the Shift button a second time turns the light off, and the knob reverts to Pedestal adjustment.

Pedestal / Knee, Chroma & Gamma:

The Pedestal adjustment controls the absolute black level of an image. Chroma controls the overall color of the image being captured. Gamma adjusts the overall brightness of an image. See SHIFT for information on Knee.

Auto Iris:

The Auto Iris mode automatically adjusts the iris and gain of the camera. To manually adjust the iris or gain, turn off this control.

Manual Iris:

The manual iris control allows the user to set the iris manual to one of the 18 settings available.

Gain:

The Gain control boosts the signal level when the iris is open all the way, and there is not enough lighting available. To manually adjust the gain Auto Iris must be off.

Rear Panel Connections and Controls (Left to Right):



Power Supply Input:

36V 2.78 Amp power supply on a 5.5mm OD x 2.5mm ID connector.

Power on RJ-45:

Power is provided on a CAT-5 cable to EZIM CCU.

RS-232 IN on RJ-45:

RS-232 Input from ProductionVIEW or PTZ controller. Daisy Chain control is not supported.

RS-232 OUT / G/L Out on RJ-45:

The HD-18 PTZ camera does not support this feature.

Tally on 2-pin Phoenix type connector:

Contact Closure lights LED on front panel allowing indication of which QCCU/camera combination is active in a multi-camera/QCCU installation. A tally command will also be sent to the camera to illuminate the LED on the cameras that have on-board tally lights (AW Series cameras).

G/L Input on BNC-F:

This option is not available for the HD-18 camera.

Camera Feature Switches:

The QCCU interface has an 8-position dip switch on the rear panel to allow future functionality.

Y-Gain:

Adjusts Y-Gain and allows the user to fine tune the video signal especially over longer cable lengths. Adjust to system requirements.

Distance:

Distance Adjustments for CAT-5 cable (<100', 200', 300', 400'+) equalizes the length of the twisted pairs for improved video performance.

Video Outputs:

Four video signals can be transmitted from the EZIM CCU concurrently allowing the CCU system to return HD and SD (composite video on cameras with simultaneous outputs, such as the HD-18) at the same time. Note: Y-C (S-Video is not available on the HD-18 camera).

Connector Labels and Supported Video Signals

Y/Y:	Y of YPbPr on BNC-F connector
PB/C:	PB of YPbPr on BNC-F connector
PR:	PR of YPbPr on BNC-F connector
COMP:	Composite (CVBS) Video on BNC-F connector

Video RJ-45

Return of the camera's four (4) video signals from the EZIM CCU to the Quick-Connect CCU on CAT-5 cable.

First Time Set-up with the WallVIEW CCU HD-18:

WallVIEW CCU HD-18 was designed to be exceptionally easy to use and operate. There is documentation at the back of the manual for pin-outs for all of the connectors on the WallVIEW CCU HD-18 camera.

Getting Started:

First, set up the HD and SD output resolutions for the camera, along with IR output, baud rate and image flip. On the next page are the options for the switches that are found on the back of the camera.

Figure 5: Dip Switch and HD Video Output Resolution Setting Options for the HD-18 Camera

DIP SWITCH SETTINGS										HD VIDEO SELECT			
IR 1 1 & 2 UP	IR OUT OFF	9600 bps	SD NTSC	SD 4:3 6 & 7 UP		IMAGE FLIP OFF	TEST BARS OFF	10 OFF		0	720p/59.94	8	576i/25
<input type="checkbox"/>	<input type="checkbox"/>	<input type="checkbox"/>	<input type="checkbox"/>	<input type="checkbox"/>	<input type="checkbox"/>	<input type="checkbox"/>	<input type="checkbox"/>	<input type="checkbox"/>	<input type="checkbox"/>	1	1080i/59.94	9	---
<input type="checkbox"/>	<input type="checkbox"/>	<input type="checkbox"/>	<input type="checkbox"/>	<input type="checkbox"/>	<input type="checkbox"/>	<input type="checkbox"/>	<input type="checkbox"/>	<input type="checkbox"/>	<input type="checkbox"/>	2	1080p/59.94	A	---
<input type="checkbox"/>	<input type="checkbox"/>	<input type="checkbox"/>	<input type="checkbox"/>	<input type="checkbox"/>	<input type="checkbox"/>	<input type="checkbox"/>	<input type="checkbox"/>	<input type="checkbox"/>	<input type="checkbox"/>	3	1080p/60	B	---
<input type="checkbox"/>	<input type="checkbox"/>	<input type="checkbox"/>	<input type="checkbox"/>	<input type="checkbox"/>	<input type="checkbox"/>	<input type="checkbox"/>	<input type="checkbox"/>	<input type="checkbox"/>	<input type="checkbox"/>	4	720p/50	C	---
<input type="checkbox"/>	<input type="checkbox"/>	<input type="checkbox"/>	<input type="checkbox"/>	<input type="checkbox"/>	<input type="checkbox"/>	<input type="checkbox"/>	<input type="checkbox"/>	<input type="checkbox"/>	<input type="checkbox"/>	5	1080i/50	D	---
IR 2 ON	IR 3 ON	ON	38400 bps	SD PAL	SD SQ	SD LB	ON	ON	ON	6	1080p/50	E	1080p/30
1	2	3	4	5	6	7	8	9	10	7	480i/29.97	F	1080p/25

Note: The Test Bars are non standard, but are 75% YCbCr Color Bars and are intended as a convenience for testing the signal path only.

- IR 1, 2 & 3: These settings, using switches 1 & 2, determine the IR frequency of the IR remote control that was supplied with your camera. The IR remote has the capability of operating up to three different PTZ cameras from one remote, using the selector buttons at the top of the remote.
- IR Out: The IR output is sent on the RJ-45, RS-232 jack on the back of the camera. NOTE: When using the Quick-Connect CCU, the IR output must be in the Off position (up).
- Baud Rate: The options for baud rate are either 9600 or 38,400 for RS-232.
- SD Output Frequency: Select either NTSC or PAL as the output for the camera's SD signal that is transmitted on the BNC connector.
- SD Output Size: Three options are available for the SD output, select from crop, squeeze or letterbox.
- Image Flip: Turning Image Flip on (switch down), will allow the camera to be inverted.
- Test Bars: Turning this switch on will override the camera video output and send test video bars from the camera to the CCU to allow more accurate setting of the video level at the CCU.
- Switch 10: This switch is unused, and should be left in the OFF position.

RS-232 Cabling

For RS-232, use a standard CAT-5 cable (568B termination for RJ-45 connectors) from the RS-232 port on the back of a Vaddio ProductionVIEW camera controller or switcher. If the camera will be connected to a third-party control system (such as AMX or Crestron), a DB-9 to RJ-45 adapter cable is supplied with the camera for RS-232.

IR Output – Switch 3

When operating the HD-18 camera with the Quick-Connect CCU, the IR Output must be set to the OFF position on the back of the camera. If it is not turned off, it will interfere with proper operation of the PTZ camera.

INSTALLATION

The WallVIEW CCU HD-18 product was specifically designed for installation on a vertical wall surface with CAT-5 cable connectivity for Power, Video and Control signaling (three cables are required). Installation is simplified in that no custom 8-Pin mini-din cables or expensive S-Video plenum cables are needed and no power outlets are required near the camera bracket. All cabling is routed to the head-end using CAT-5 cables. The use of “pass-thru” RJ-45 connectors should not be used (see notice on page 2).

Before Installing

- Locate the camera mounting location paying close attention to camera viewing angles, lighting conditions, possible line of site obstructions, and checking for in-wall obstructions where the camera is to be mounted. Pick a mounting location to optimize the performance of the camera.
- Pre-wire all cabling as required (see the wiring diagram example below).
- The Thin Profile Wall Mount for the WallVIEW CCU HD-18 can be mounted directly to a 2-gang wall box or can be mounted to the drywall using four dry wall anchors.

Connecting the EZIM CCU to the EZIM CCU Slot Card in the HD-18 Camera

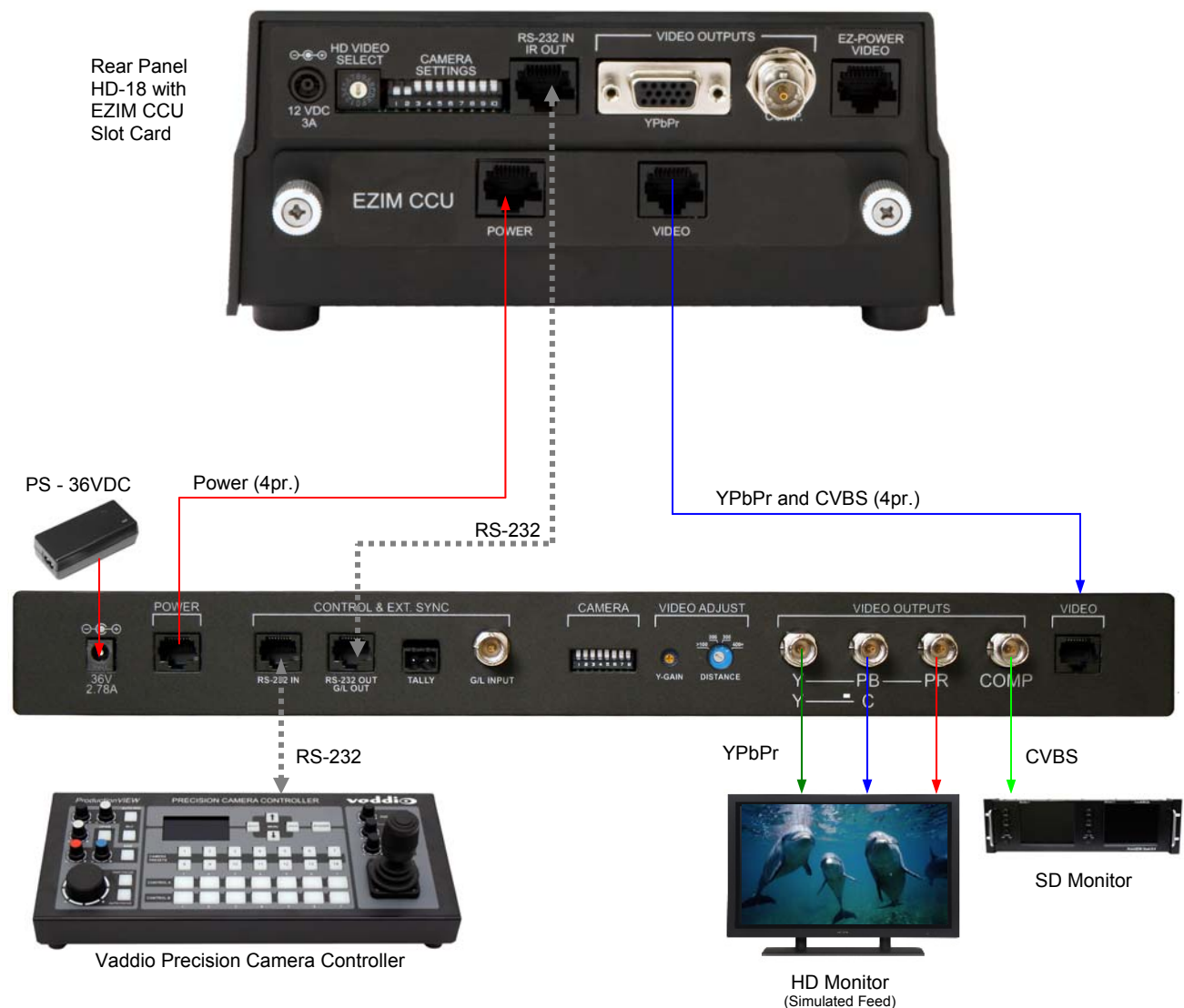

MOUNTING AND INSTALLATION INSTRUCTIONS

Step 1:

After determining the optimum location of the camera system, route the required 3 (three) CAT-5 cables from the camera to the Quick-Connect CCU interface located at the head-end. The three CAT-5 cables should feed-through the oval slot located on the rear flange of the wall mount. If the bracket is to be mounted on a 2-gang wall box, use the screws supplied with the wall box cover plate to attach the Thin Profile Wall Mount. If mounting to the drywall with wall anchors, use four (4) quality wall anchors. The mounting holes are slotted and are 90° opposing to provide easy leveling. Level the mount and tighten down the mounting screws.

Step 2:

Locate the EZIM CCU Card (see the front page of the manual for a picture of the device). Remove the blank panel below the connectors on the back of the camera. Slide the EZIM CCU Card into the slot on the back of the camera until the connector is seated into the camera. Tighten the thumb screws on the EZIM CCU Card.

Note: IR Output – Switch 3

When operating the HD-18 camera with the Quick-Connect CCU, the IR Output must be set to the OFF position on the back of the camera. If it is not turned off, it will interfere with proper operation of the PTZ camera.

Step 3:

Follow the sample wiring diagram on the previous page for connecting the CAT-5 cables to the camera and Quick-Connect CCU, using a Vaddio ProductionVIEW Precision Camera Controller. Additional diagrams are available on our website for installation with other equipment.



IMPORTANT NOTE: Check all CAT-5 cables for continuity in advance of the final connection. Plugging the POWER CAT-5 Cable into the wrong RJ-45 may cause damage to the camera system and void the warranty.

Step 4:

Place the camera onto the camera mount and using the ¼”-20 screws to secure the camera to the mount.

Step 5:

Connect the Vaddio 36 VDC power supply to an AC outlet. Power will travel down the Power CAT-5 cable to the camera. The camera will “Home” to a centered position ready for control information from the IR remote control or RS-232 camera controller of the integrators’ choice. To insure proper continuity of control and operation of the cameras, the RS-232 controller (control system or joystick) should be powered on after the camera.

Step 6:

For setting up the CCU, first make sure that the video monitor that you are using is set up correctly, and is delivering accurate color reproduction. Next, adjust the iris level of the camera, so that brighter areas are not washed out. After that is done, adjust the Pedestal level so that the black levels are not too dark, and not too light. After this, adjust the Red & Blue Gain, Gamma, Detail, Knee and Chroma. NOTE: Gain (next to Iris, should be left at 0 (zero), unless lighting is inadequate, then turn it to a level where the signal brightness is at an appropriate level. Gain adds additional noise (grain) to the video the higher it is turned up.

WallVIEW CCU HD-18	
Part Numbers	WallVIEW CCU HD-18 999-6907-000 (North America) WallVIEW CCU HD-18 999-6907-000W (Arctic White - North America) WallVIEW CCU HD-18 999-6907-001 (INT'L) WallVIEW CCU HD-18 999-6907-001 (Arctic White - INT'L)
• Vaddio ClearVIEW HD-18	
Image Device	1/3" CCD
Picture Elements	1.3 Megapixels
Signal System	HD: 1080p, 1080i or 720p @ 59.94; 1080p @ 60; 1080p, 1080i or 720p @ 50 SD: Composite NTSC or PAL (simultaneous with HD) NOTE: SD output not on Quick-Connect SR
Lens	18x Optical Zoom
Focal Length	f=4.7 to 84.6mm
Horizontal Viewing Angle	3.2 to 55.2 degrees (16:9)
Frame Delay	1 frame
Video S/N Ratio	>50 dB
Invertible	Yes
Minimum Illumination	1.8 lux
Control Protocol	VISCA
Serial Communication	RS-232 (9600 or 38,400)
Pan Range	+170 degrees to -170 degrees
Tilt Range	+90 degrees to -30 degrees
Pan/Tilt Speed	0.25° to 60° degrees/second
Preset Positions	16 (internal), 6 recalled via IR Remote
Weight	5.8 lbs. (2.63 kg.)
• Quick-Connect CCU Interface (QCCU)	
Connectors	Power Connector: 5.5mm OD x 2.5mm ID Power RJ-45: Supplies 36V to EZIM CCU Control In RJ-45: Accepts RS-232 from ProductionVIEW or other non-daisy-chain control systems Control Out RJ-45: Unused Tally: 2-Pin Phoenix type spring cage connector Video Inputs: BNC Connector for Sync (not available on HD-18) Video Outputs: BNC Connectors for HD Analog Component (Y,PB,PR) / SD (Composite) Video RJ-45: Transports HD video from camera EZIM CCU
Camera Select Switch	For Future Use – All switches should be in the down position
Video Adjustments	Y-Gain (luminance gain) for fine tuning over longer cable distances Distance Compensation: 100', 200', 300', 400'+
CAT-5 Cable Distance	Up to 500' (152.4m)
Power Supply	36 VDC, 2.78 Amp
Dimensions	1-RU Rack Mount - 1.75" H x 19" W x 6" D (4.45 cm x 4.26 cm x 15.24 cm)
• Thin Profile Wall Mount HD-18	
Materials	12-Gauge CRS with Black Powder Coat Paint
Dimensions	5.125" H x 6.75" W x 10" D (13 cm x 17.15 cm x 25.4 cm)
Weight	Approx. 2.4 lbs. (1.1kg)

The WallVIEW HD-18 PTZ offers the following accessories for a complete, professional installation.



15-pin to Male BNC output cable
440-5600-001 (3 ft.)
440-5600-002 (6 ft.)
440-5600-003 (7 inch.)



Drop Down Ceiling Mount
535-2225-296

Compliance and CE Declaration of Conformity (HD-18 PTZ Camera)



FCC Part 15 Compliance

This equipment has been tested and found to comply with the limits for a Class A digital device, pursuant to Part 15 of the FCC Rules. These limits are designed to provide reasonable protection against harmful interference when the equipment is operated in a commercial environment. This equipment generates, uses, and can radiate radio frequency energy and, if not installed and used in accordance with the instruction manual, may cause harmful interference to radio communications. Operation of this equipment in a residential area is likely to cause harmful interference in which case the user will be required to correct the interference at his/her own expense.

Operation is subject to the following two conditions: (1) This device may not cause interference, and (2) This device must accept any interference including interference that may cause undesired operation of the device.

Changes or modifications not expressly approved by Vaddio can affect emission compliance and could void the user's authority to operate this equipment.



ICES-003 Compliance

This digital apparatus does not exceed the Class A limits for radio noise emissions from digital apparatus set out in the Radio Interference Regulations of the Canadian Department of Communications.

Le présent appareil numérique n'émet pas de bruits radioélectriques dépassant les limites applicables aux appareils numériques de la classe A prescrites dans le Règlement sur le brouillage radioélectrique édicté par le ministère des Communications du Canada.



European Compliance

This product has been evaluated for Electromagnetic Compatibility under the EMC Directive for Emissions and Immunity and meets the requirements for a Class A digital device. In a domestic environment this product may cause radio interference in which case the user may be required to take adequate measures.

Standard(s) To Which Conformity Is Declared:

EMC Directive 2004/108/EC

EN 55022 A: 2006 + A1 2007 (CISPR 22:2005/A1:2005) Conducted and Radiated Emissions

- AS/NZS CISPR 22: 2006, Australia and New Zealand - Conducted and Radiated Emissions
- VCCI V-3/2009.04, Japan - Conducted and Radiated Emissions

EN 55024: 1998 + Amendments A1: 2001 + A2: 2003 - Electromagnetic Compatibility - Immunity

EN 61000-4-2 Electrostatic Discharge

EN 61000-4-3 Radiated Immunity

EN 61000-4-4 Electrical Fast Transients

EN 61000-4-5 Surge Immunity

EN 61000-4-6 Conducted Immunity

EN 61000-4-8 Power Frequency Magnetic Field

EN 61000-4-11 Voltage Dips, Interrupts and Fluctuations

Compliance and CE Declaration of Conformity (Quick-Connect CCU and EZIM CCU)



FCC Part 15 Compliance

This equipment has been tested and found to comply with the limits for a Class A digital device, pursuant to Part 15 of the FCC Rules. These limits are designed to provide reasonable protection against harmful interference when the equipment is operated in a commercial environment. This equipment generates, uses, and can radiate radio frequency energy and, if not installed and used in accordance with the instruction manual, may cause harmful interference to radio communications. Operation of this equipment in a residential area is likely to cause harmful interference in which case the user will be required to correct the interference at his/her own expense.

Operation is subject to the following two conditions: (1) This device may not cause interference, and (2) This device must accept any interference including interference that may cause undesired operation of the device.

Changes or modifications not expressly approved by Vaddio can affect emission compliance and could void the user's authority to operate this equipment.



ICES-003 Compliance

This digital apparatus does not exceed the Class A limits for radio noise emissions from digital apparatus set out in the Radio Interference Regulations of the Canadian Department of Communications.

Le présent appareil numérique n'émet pas de bruits radioélectriques dépassant les limites applicables aux appareils numériques de la classe A prescrites dans le Règlement sur le brouillage radioélectrique édicté par le ministère des Communications du Canada.



European Compliance

This product has been evaluated for Electromagnetic Compatibility under the EMC Directive for Emissions and Immunity and meets the requirements for a Class A digital device. In a domestic environment this product may cause radio interference in which case the user may be required to take adequate measures.

Standard(s) To Which Conformity Is Declared:

EMC Directive 89/336/EEC

EN 55022A	Conducted and Radiated Emissions
EN 55024	Electromagnetic Compatibility - Immunity
EN 61000-4-2	Electrostatic Discharge Requirements
EN 61000-4-3	Radiated Electromagnetic Field Requirement
EN 61000-4-4	Electrical Fast Transients / Burst Requirements
EN 61000-4-5	Surge Requirements
EN 61000-4-6	Conducted Immunity Requirements
EN 61000-4-8	Power Frequency Magnetic Field Requirements
EN 61000-4-11	Voltage Dips, Interrupts and Fluctuations Requirements

Warranty Information:

Hardware* Warranty - One year limited warranty on all parts. Vaddio warrants this product against defects in materials and workmanship for a period of one year from the day of purchase from Vaddio. If Vaddio receives notice of such defects during the warranty period, they will, at their option, repair or replace products that prove to be defective.

Exclusions - The above warranty shall not apply to defects resulting from: improper or inadequate maintenance by the customer, customer applied software or interfacing, unauthorized modifications or misuse, operation outside the normal environmental specifications for the product, use of the incorrect power supply, improper extension of the power supply cable or improper site operation and maintenance.

Vaddio Customer service – Vaddio will test, repair, or replace the product or products without charge if the unit is under warranty and is found to be defective. If the product is out of warranty, Vaddio will test then repair the product or products. The cost of parts and labor charge will be estimated by a technician and confirmed by the customer prior to repair. All components must be returned for testing as a complete unit. Vaddio will not accept responsibility for shipment after it has left the premises.

Vaddio Technical support - Vaddio technicians will determine and discuss with the customer the criteria for repair costs and/or replacement. Vaddio Technical Support can be contacted through one of the following resources: e-mail support at support@vaddio.com or online at www.vaddio.com.

Return Material Authorization (RMA) number - Before returning a product for repair or replacement, request an RMA from Vaddio's technical support. Provide a technician with a return phone number, e-mail address, shipping address, and product serial numbers and describe the reason for repairs or returns as well as the date of purchase and proof of purchase. Include your assigned RMA number in all correspondence with Vaddio. Write your assigned RMA number on the outside of the box when returning the product.

Voided warranty – The warranty does not apply if the original serial number has been removed or if the product has been disassembled or damaged through misuse, accident, modifications, or unauthorized repair. Cutting the power supply cable on the secondary side (low voltage side) to extend the power to the device (camera or controller) voids the warranty for that device.

Shipping and handling - Vaddio will not pay for inbound shipping transportation or insurance charges or accept any responsibility for laws and ordinances from inbound transit. Vaddio will pay for outbound shipping, transportation, and insurance charges for all items under warranty but will not assume responsibility for loss and/or damage by the outbound freight carrier.

• If the return shipment appears damaged, retain the original boxes and packing material for inspection by the carrier. Contact your carrier immediately.

Products not under warranty - Payment arrangements are required before outbound shipment for all out of warranty products.

*Vaddio manufactures its hardware products from parts and components that are new or equivalent to new in accordance with industry standard practices.

Other General Information:

Care and Cleaning

Do not attempt to take this product apart at any time. There are no user-serviceable components inside.

- Do not spill liquids in the WallVIEW CCU HD-18
- Keep this device away from food and liquid
- For smears or smudges on the console, wipe with a clean, soft cloth with a light duty household cleaner that leaves no residue. Repeated use of a "Windex®" type product with vigorous pressure may remove some of the silk screening and this will void the warranty.
- Do not use any abrasive chemicals.

Operating and Storage Conditions:

Do not store or operate the WallVIEW CCU HD-18 under the following conditions:

- Temperatures above 40°C (104°F) or temperatures below 0°C (32°F)
- High humidity, condensing or wet environments or In inclement weather
- Dusty environments

- Under severe vibration

Appendix 1:
Video Pin-out Table for WallVIEW HD-18

Pin	YPbPr
1	Pr
2	Y
3	Pb
4	-
5	-
6	Pr GND
7	Y GND
8	Pb GND
9	-
10	-
11	-
12	-
13	-
14	-
15	-

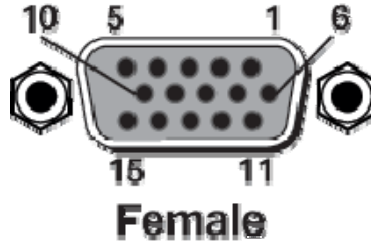

EZIM CCU Slot card Pin out Assignments (568B Wiring Standard)



Power Connector RJ-45

Pin	YPbPr
1	Power+
2	Power-
3	Power+
4	Power-
5	Power+
6	Power-
7	Power+
8	Power-

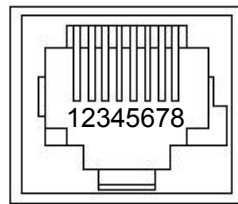

POWER

Video Connector RJ-45

Pin	VIDEO
1	CVBS+
2	CVBS GND
3	Y+
4	PB+
5	PB GND
6	Y GND
7	PR+
8	PR-

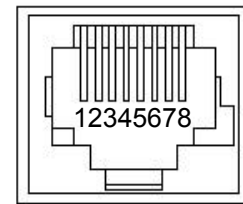

VIDEO

Appendix 2: Camera Dimensions

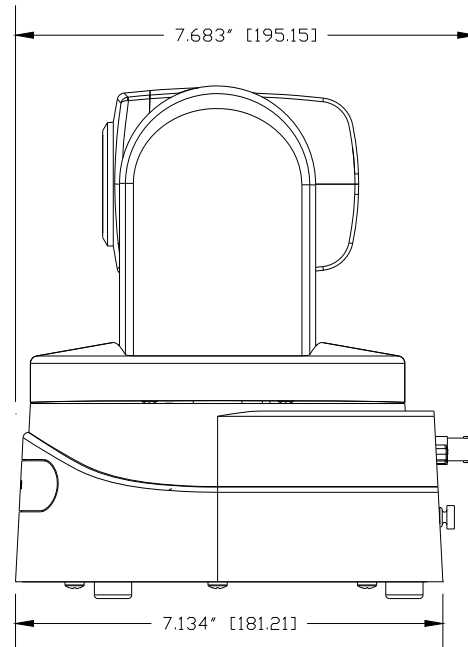
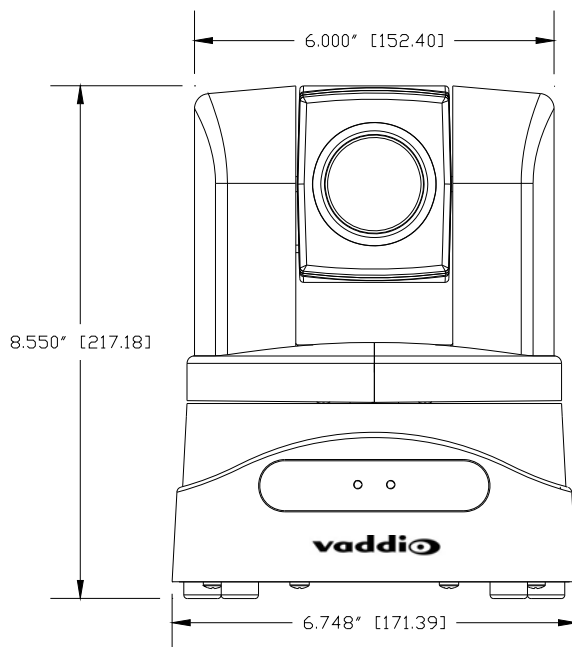

Appendix 3: Communication Specification

Communication Speed: 9600 bps (default)
 Start bit: 1
 Stop bit: 1
 Data bits: 8
 Parity: None
 No Flow control

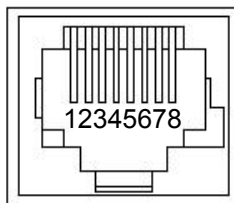

Pin #	RJ-45 RS-232 and IR Out Pins
1)	Unused
2)	Unused
3)	IR Out (TTL level)
4)	IR Output (Diff Signal to HD-18 Quick-Connect)
5)	IR Ground (Diff Signal to HD-18 Quick-Connect)
6)	GND (GND of IR Short Range - Pin 3)
7)	RXD (from TXD of control source)
8)	TXD (to RXD of control source)

NOTE: The Vaddio ClearVIEW HD-18 Control Protocol is similar, but not identical to the Sony™ VISCA™ command set in order to be compatible with several popular control devices. Not all VISCA commands are supported and there are many HD-18 specific commands in the following Command and Inquiry Lists.

HD-18 Command List (1/2)

Command Set	V	Command	Command Packet	Comments
AddressSet	Y	Broadcast	88 30 01 FF	Address Set
IF_Clear	Y	Broadcast	88 01 00 01 FF	I/F Clear
CommandCancel	Y		81 2p FF	p: Socket No(=1 to2)
CAM_Power	Y	On	81 01 04 00 02 FF	Power On/Off
	Y	Off	81 01 04 00 03 FF	
CAM_Zoom	Y	Stop	81 01 04 07 00 FF	p:0(Slow) to 7(Fast) p:0(Slow) to 7(Fast) pqr: Zoom Position* V:(Speed) 0-7
	Y	Tele(Standard)	81 01 04 07 02 FF	
	Y	Wide(Standard)	81 01 04 07 03 FF	
	Y	Tele(Variable)	81 01 04 07 2p FF	
	Y	Wide(Variable)	81 01 04 07 3p FF	
	Y	Direct	81 01 04 47 0p 0q 0r 0s FF	
	Y	Direct(Variable)	81 01 7E 01 4A 0V 0p 0q 0r 0s FF	
CAM_Focus	Y	Stop	81 01 04 08 00 FF	Supported as 'Standard' Supported as 'Standard'
	Y	Far(Standard)	81 01 04 08 02 FF	
	Y	Near(Standard)	81 01 04 08 03 FF	
	Y	Far(Variable)	81 01 04 08 2p FF	
	Y	Near(Variable)	81 01 04 08 3p FF	
	Y	AutoFocus	81 01 04 38 02 FF	
	Y	ManualFocus	81 01 04 38 03 FF	
	Y	Auto/Manual	81 01 04 38 10 FF	
CAM_WB	Y	Auto	81 01 04 35 00 FF	
	Y	Manual	81 01 04 35 05 FF	
CAM_RGain	Y	Reset	81 01 04 03 00 FF	pqr:000-1ff
	Y	Up	81 01 04 03 02 FF	
	Y	Down	81 01 04 03 03 FF	
	Y	Direct	81 01 04 43 00 0p 0q 0r FF	
CAM_BGain	Y	Reset	8x 01 04 04 00 FF	pqr:000-1ff
	Y	Up	8x 01 04 04 02 FF	
	Y	Down	81 01 04 04 03 FF	
	Y	Direct	81 01 04 44 00 0p 0q 0r FF	
CAM_AE	Y	Full Auto	81 01 04 39 00 FF	Auto Exposure Mode Manual Control Mode Shutter Priority Mode Exposure Priority Mode (default) AGC Priority Mode
	Y	Manual	81 01 04 39 03 FF	
	Y	Shutter Priority	81 01 04 39 0A FF	
	Y	Iris Priority	81 01 04 39 0B FF	
	Y	Bright	81 01 04 39 0D FF	
CAM_Iris	Y	Reset	81 01 04 0B 00 FF	pq(0x00-0x11)
	Y	Up	81 01 04 0B 02 FF	
	Y	Down	81 01 04 0B 03 FF	
	Y	Direct	81 01 04 4B 00 00 0p 0q FF	
CAM_Gain	Y	Reset	81 01 04 0C 00 FF	pq(0x00-0x1E)
	Y	Up	81 01 04 0C 02 FF	
	Y	Down	81 01 04 0C 03 FF	
	Y	Direct	81 01 04 4C 00 00 0p 0q FF	

HD-18 Command List (2/2)

Command Set	V	Command	Command Packet	Comments	
CAM_Backlight	Y	On	81 01 04 33 02 FF		
	Y	Off	81 01 04 33 03 FF		
CAM_Aperture	Y	Reset	81 01 04 02 00 FF		
	Y	Up	81 01 04 02 02 FF		
	Y	Down	81 01 04 02 03 FF		
	Y	Direct	81 01 04 42 00 00 0p 0q FF	pq(0x00-0x3F)	
CAM_Memory	Y	Reset	81 01 04 3F 00 0p FF	p:Memory No(=0-0xf)	
	Y	Set	81 01 04 3F 01 0p FF		
	Y	Recall	81 01 04 3F 02 0p FF		
CAM_IDWrite	Y		81 01 04 22 0p 0q 0r 0s FF	pqrs:Camera ID(==0000 – FFFF)	
IR_Receive	Y	On	81 01 06 08 02 FF		
	Y	Off	81 01 06 08 03 FF		
	Y	On/Off	81 01 06 08 10 FF		
IR_ReceiveReturn	N+	On	81 01 7D 01 03 00 00 FF		
	N+	Off	81 01 7D 01 13 00 00 FF		
Pan-tiltDrive	Y	Up	81 01 06 01 VV WW 03 01 FF	WW: Pan Speed (0x01-0x18) VV:Tilt Speed(0x01-0x14)	
	Y	Down	81 01 06 01 VV WW 03 02 FF		
	Y	Left	81 01 06 01 VV WW 01 03 FF		
	Y	Right	81 01 06 01 VV WW 02 03 FF		
	Y	UpLeft	81 01 06 01 VV WW 01 01 FF		
	Y	UpRight	81 01 06 01 VV WW 02 01 FF		
	Y	DownLeft	81 01 06 01 VV WW 01 02 FF		
	Y	DownRight	81 01 06 01 VV WW 02 02 FF		
	Y	Stop	81 01 06 01 VV WW 03 03 FF		
	Y	Absolute Position	81 01 06 02 VV WW 0Y 0Y 0Y 0Y 0Z 0Z 0Z 0Z FF 0Y 0Y 0Y 0Y 0Z 0Z 0Z 0Z FF		YYYY: Pan Position* ZZZZ: Tilt Position*
	Y	Home			
	Y	Reset	81 01 06 04 FF 81 01 06 05 FF		
	Y				
Tally	Y	On	81 01 7E 01 0A 00 02 FF		
	Y	Off	81 01 7E 01 0A 00 03 FF		
Preset Pan Speed	Y	Pan/Tilt Speed	81 01 7E 01 0B WW VV ZZ FF	WW: Pan Speed (0x01-0x18) VV:Tilt Speed(0x01-0x14) ZZ:Zoom Speed(0-7);	
Motor Config	Y	Hard Motor Stops	81 01 7E 01 70 00 00 FF		
	Y	Soft Motor Stops	81 01 7E 01 70 00 01 FF		
BLK.Enhance	Y	Pedestal	81 01 7E 53 00 00 0p 0q FF	pq: Black Level (0x01-0xFD)	
GMA.Enhance	Y	Gamma	81 01 7E 54 00 00 0p 0q FF	pq: Gamma (0x00-0x8F)	
CRM.Enhance	Y	Chroma	81 01 7E 55 00 00 0p 0q FF	pq: Chroma (0x08-0x1F)	
KNE.Enhance	Y	Knee	81 01 7E 55 00 00 0p 0q FF	pq: Knee (0x0-07F)	
CAM_Shutter	Y	Reset	81 01 04 0A 00 FF	(Only supported in Shutter Priority Mode)	
	Y	Up	81 01 04 0A 02 FF		
	Y	Down	81 01 04 0A 03 FF		
	Y	Direct	81 01 04 4A 00 00 0p 0q FF		
CAM_ExpComp	Y	On	81 01 04 3E 02 FF	AutoExposure Off AutoExposure On	
	Y	Off	81 01 04 3E 03 FF		
	Y	Reset	81 01 04 0E 00 FF		
	Y	Up	81 01 04 0E02 FF		
	Y	Down	81 01 04 0E 03 FF		
	Y	Direct	81 01 04 4E 00 00 0p 0q FF		
CAM_ICR Cut Filter	Y	ICR On	81 01 04 01 02 FF	ICR On	
	Y	ICR Off	81 01 04 01 03 FF	ICR Off	

Additional Information:

Pan Range: 8044 – 7FBC (-32,700 to +32,700)

Tilt Range: E891 – 4C2B (-5,999 to +19,499)

* Actual Pan/Tilt ranges defined in Inquiry list

HD-18 Inquiry List (1/1)

Inquiry Command	V	Command	Command Packet	Comments
CAM_PowerInq	Y	81 09 04 00 FF	y0 50 02 FF y0 50 03 FF	On Off(Standby)
CAM_ZoomPosInq	Y	81 09 04 47 FF	y0 50 0p 0q 0r 0s FF	pqr: Zoom Position
CAM_WBModelInq	Y	81 09 04 35 FF	y0 50 00 FF y0 50 05 FF	Auto Manual
CAM_RGain	Y	81 09 04 43 FF	y0 50 00 0p 0q 0r FF	pqr:000-1ff
CAM_BGain	Y	81 09 04 44 FF	y0 50 00 0p 0q 0r FF	pqr:000-1ff
CAM_AEModelInq	Y	81 09 04 39 FF	y0 50 00 FF y0 50 03 FF	Auto Exposure Mode Manual Control Mode
CAM_Iris	Y	81 09 04 4B FF	y0 50 00 00 0p 0q FF	pp(0x00-0x11)
CAM_Gain	Y	81 09 04 4C FF	y0 50 00 00 0p 0q FF	pp(0x00-0x1E)
CAM_BacklightModelInq	Y	81 09 04 33 FF	y0 50 02 FF y0 50 03 FF	On Off
CAM_ApertureInq	Y	81 09 04 42 FF	y0 50 00 00 0p 0q FF	pp(0x00-0x3F)
CAM_MemoryInq	Y	81 09 04 3F FF	y0 50 0p FF	p:Memory No(=0-0xf)
CAM_IDInq	Y	81 09 04 3F FF	y0 50 0p 0q 0r 0s FF	pqrs:(0000 – FFFF)
CAM_ReceiveInq	Y	81 09 06 08 FF	y0 50 02 FF y0 50 03 FF	On Off
Pan-TiltMaxSpeedInq	Y	81 09 06 11 FF	y0 50 WW VV FF	WW: Pan Speed (0x01-0x18) VV:Tilt Speed(0x01-0x14)
Pan-tiltPositionInq	Y	81 09 06 12 FF	y0 50 0Y 0Y 0Y 0Y 0Z 0Z 0Z 0Z FF	YYYY: Pan (0x0100-0x1800) ZZZZ:Tilt (0x0100-0x1400)
TallyInq	Y Y	81 09 7E 01 0A FF	y0 50 02 FF y0 50 03 FF	On Off
PresetSpeedInq	Y	81 09 7E 01 0B FF	y0 50 WW VV ZZ FF	WW: Pan Speed (0x01-0x18) VV:Tilt Speed(0x01-0x14) ZZ:Zoom Speed(0-7);
Motor Config	Y	81 09 7E 01 70 FF	y0 50 00 FF y0 50 01 FF	Hard Motor Stops Soft Motor Stops
BLK.Enhance	Y	81 01 7E 53 FF	y0 50 00 00 0p 0q FF	pq: Black Level (0x01-0xFD)
GMA.Enhance	Y	81 01 7E 54 FF	y0 50 00 00 0p 0q FF	pq: Gamma (0x00-0x8F)
CRM.Enhance	Y	81 01 7E 55 FF	y0 50 00 00 0p 0q FF	pq: Chroma (0x08-0x1F)
KNE.Enhance	Y	81 01 7E 56 FF	y0 50 00 00 0p 0q FF	pq: Knee (0x0-07F)
CAM_AEModelInq	Y	81 09 04 39 FF	y0 50 00 FF y0 50 03 FF y0 50 0A FF y0 50 0B FF y0 50 0D FF	Auto Exposure Mode Manual Control Mode Shutter Priority Mode Exposure Priority Mode AGC Priority Mode
CAM_ShutterPosInq	Y	81 09 04 4A FF	y0 50 00 00 0p 0q FF	pp: ShutterPosition (Only supported in Shutter Priority Mode)
CAM_ExpCompModelInq	Y	81 09 04 3E FF	y0 50 02 FF y0 50 03 FF	On - AE Mode Off Off – AE Mode On
CAM_ExpCompPosInq	Y	81 09 04 4E FF	y0 50 00 00 0p 0q FF	pq: ExpComp Pos -Iris Position
CAM_ICRModelInq	Y	81 09 04 01 FF	y0 50 02 FF y0 50 03 FF	ICR On ICR Off



9433 Science Center Drive, Minneapolis, MN 55428
Toll Free: 800-572-2011 • Phone: 763-971-4400 • FAX: 763-971-4464
www.vaddio.com

©2010 Vaddio - All Rights Reserved. Reproduction in whole or in part without written permission is prohibited. Specifications and pricing are subject to change without notice. Vaddio, ProductionVIEW, Quick-Connect, ControlVIEW, WallVIEW, EZCamera, EZIM and PowerRite are registered trademarks of Vaddio. All other trademarks are property of their respective owners. Document Number 341-889 Rev. C