

Using the VISCA RS-422 Connector Plug

- 1 Insert a wire (AWG Nos. 28 to 18) into the desired wire opening on the VISCA RS-422 connector plug, and tighten the screw for that wire using a flat-head screwdriver.

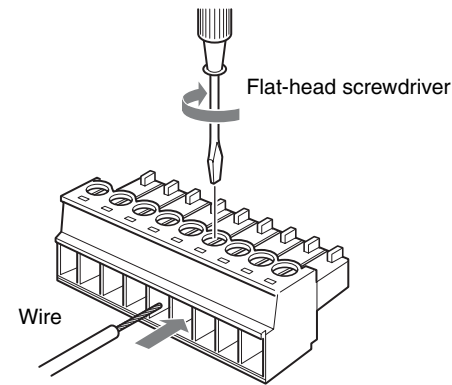

- 2 Insert the VISCA RS-422 connector plug into the VISCA RS-422 connector.

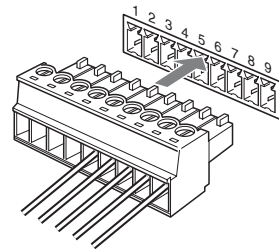

To remove the connector plug

Grasp both ends of the VISCA RS-422 connector plug and pull it out as shown in the illustration.

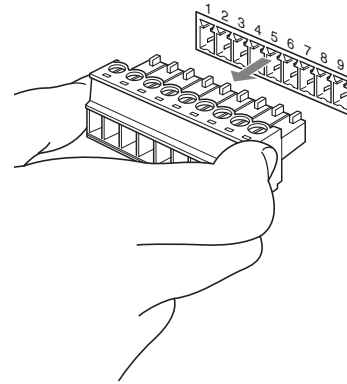

Notes

- In order to stabilize the voltage level of the signal, connect both ends to GND.
- When the connections using the VISCA RS-422 connectors are made, the VISCA RS-232C connection is not available.
- The maximum connection distance with the VISCA RS-422 connection is approximately 1,200 m (3,937 feet).

SONY®

HD 3CCD Color Video Camera

Operating Instructions

For Customer in China

根据中华人民共和国信息产业部第39号令《电子信息产品污染控制管理办法》及标准中要求的“有毒有害物质或元素名称及含量”等信息，本产品相关信息请参考以下链接：
<http://pro.sony.com.cn>



Printed on recycled paper.

Sony Corporation <http://www.sony.net/>

Printed in Japan

BRC-H700

© 2005 Sony Corporation



3903974150

Owner's Record

The model and serial numbers are located on the bottom. Record these numbers in the spaces provided below. Refer to these numbers whenever you call upon your Sony dealer regarding this product.

Model No. BRC-H700

Serial No. _____

WARNING

To reduce a risk of fire or electric shock, do not expose this product to rain or moisture.

To avoid electrical shock, do not open the cabinet. Refer servicing to qualified personnel only.

WARNING

Use the Sony MPA-AC1 AC power adapter provided with this equipment as a power supply source. Any other power sources may result in hazards such as a fire. This product has no power switch.

Disconnect device of this equipment is the mains plug of the AC adapter.

The mains plug on this equipment must be used to disconnect mains power.

Please ensure that the socket outlet is installed near the equipment and shall be easily accessible.

In the event of abnormal operations, disconnect the mains plug.

WARNING (For Installers only)

Instruction for installing the equipment on the ceiling: After the installation, ensure the connection is capable of supporting four times the weight of the equipment downwards.

IMPORTANT

Nameplate is located on the bottom.

ATTENTION

The electromagnetic fields at the specific frequencies may influence the picture of this unit.

For customers in the U.S.A.

This device complies with Part 15 of the FCC Rules. Operation is subject to the following two conditions:
(1) This device may not cause harmful interference, and (2) this device must accept any interference received, including interference that may cause undesired operation.

This equipment has been tested and found to comply with the limits for a Class A digital device, pursuant to Part 15 of the FCC Rules. These limits are designed to provide reasonable protection against harmful

interference when the equipment is operated in a commercial environment. This equipment generates, uses, and can radiate radio frequency energy and, if not installed and used in accordance with the instruction manual, may cause harmful interference to radio communications. Operation of this equipment in a residential area is likely to cause harmful interference in which case the user will be required to correct the interference at his own expense.

You are cautioned that any changes or modifications not expressly approved in this manual could void your authority to operate this equipment.

All interface cables used to connect peripherals must be shielded in order to comply with the limits for a digital device pursuant to Subpart B of Part 15 of FCC Rules.

For the customers in Canada

This Class A digital apparatus complies with Canadian ICES-003.

Pour les utilisateurs au Canada

Cet appareil numérique de la classe A est conforme à la norme NMB-003 du Canada.

For the customers in Europe, Australia and New Zealand

WARNING

This is a Class A product. In a domestic environment, this product may cause radio interference in which case the user may be required to take adequate measures.

Notice for CCFC-M100HG Optical Fiber Cable

Only trained and qualified personnel should be allowed to install this equipment with the cable.

WARNING :

The cable is rated flammability class VW-1 and may be for indoor use only in some countries. Use appropriate alternative cables in accordance with the regulations and laws for each country taking the application and environment into account.

For the customers in Europe

The manufacturer of this product is Sony Corporation, 1-7-1 Konan, Minato-ku, Tokyo, Japan.

The Authorized Representative for EMC and product safety is Sony Deutschland GmbH, Hedelfinger Strasse 61, 70327 Stuttgart, Germany. For any service or guarantee matters please refer to the addresses given in separate service or guarantee documents.

This apparatus shall not be used in the residential area.

Table of Contents

Getting Started

| | |
|---|---|
| Precautions | 5 |
| Phenomena Specific to CCD Image Sensors | 5 |

Overview

| | |
|--|----|
| Features | 6 |
| System Components | 7 |
| Supplied Components and Accessories | 7 |
| Optional Products | 8 |
| System Configuration | 10 |
| Operating a BRC-H700 Camera Using the Supplied Remote Commander | 10 |
| Operating a BRC-H700 Camera Using the RM- BR300 Remote Control Unit | 10 |
| Operating Multiple BRC-H700 Cameras Using the RM-BR300 Remote Control Unit | 11 |
| Operating a BRC-H700 Camera from a Long Distance | 12 |
| Operating Multiple BRC-H700 Cameras from a Long Distance | 13 |
| Using BRC-H700 Cameras and VISCA- controllable Cameras in the Same System | 14 |
| Transmitting Audio Signals Using the BRU-H700 | 15 |
| Using the HFBK-TS1 HDV Interface Board to Input the Video and Audio Signals Mixed to the HDV Video Equipment | 16 |
| Transmitting the Audio Signal Using the BRBK- H700 HD Optical Multiplex Card and the HFBK- TS1 HDV Interface Board | 17 |
| Location and Function of Parts | 18 |
| Camera | 18 |
| Remote Commander (supplied) | 20 |
| RM-BR300 Remote Control Unit (not supplied) | 21 |
| BRU-H700 HD Optical Multiplex Unit (not supplied) | 24 |
| HFBK-SD1 SD Interface Board (not supplied) | 25 |
| HFBK-HD1 HD Interface Board (not supplied) | 25 |
| HFBK-XG1 XGA Interface Board (not supplied) | 26 |
| HFBK-TS1 HDV Interface Board (not supplied) | 26 |
| BRBK-H700 HD Optical Multiplex Card (not supplied) | 26 |

Adjusting and Setting With Menus

| | |
|--|----|
| About On-Screen Menus | 27 |
| Main Menu | 27 |
| Setting Menus | 27 |
| Operation Through Menus | 28 |
| Menu Operation Using the Supplied Remote Commander | 28 |
| Menu Operation Using the RM-BR300 Remote Control Unit | 29 |
| EXPOSURE Menu | 30 |
| Using the ND Filter | 31 |
| COLOR Menu | 31 |
| PICTURE Menu | 32 |
| FOCUS Menu | 33 |
| PAN TILT ZOOM Menu | 34 |
| SYSTEM Menu | 35 |
| STATUS Menu | 36 |
| DOWN CONVERTER Menu | 36 |
| HD-SDI Menu | 37 |
| PC-OUTPUT Menu | 38 |
| HDV Menu | 38 |

Operation Using the Supplied Remote Commander

| | |
|---|----|
| Turning on the Power | 39 |
| Pan/Tilt and Zoom Operation | 39 |
| Panning and Tilting | 39 |
| Zooming | 40 |
| Operating Multiple Cameras with the Remote Commander | 40 |
| Adjusting the Camera | 41 |
| Focusing on a Subject | 41 |
| Shooting with Back Lighting | 41 |
| Storing the Camera Settings in Memory – Presetting Feature | 42 |

Operation Using the RM-BR300 Remote Control Unit

| | |
|-----------------------------------|----|
| Turning on the Power | 43 |
| Operating Multiple Cameras | 43 |
| Pan/Tilt and Zoom Operation | 44 |
| Panning and Tilting | 44 |
| Zooming | 45 |
| Adjusting the Camera | 46 |
| Focusing on a Subject | 46 |
| Shooting with Back Lighting | 46 |
| Adjusting the White Balance | 46 |

| | |
|--|-----------|
| Adjusting the Brightness | 47 |
| Storing the Camera Settings in Memory | |
| – Presetting Feature | 48 |
| Storing Camera Settings | 48 |
| Setting the Speed of the Camera Moving to a Preset Position | 49 |

Installation and Connections

| | |
|--|-----------|
| Installation | 50 |
| Removing/Attaching the Cable Cover | 50 |
| Attaching an Interface Board | 50 |
| Installing the Camera | 51 |
| Installing the Camera in a High Position | 52 |
| Connections | 57 |
| Connecting to an AC Outlet | 57 |
| Connecting the RM-BR300 Remote Control Unit | 58 |
| Connecting a Monitor, etc. Equipped with the Analog Component (YPbPr) Input Connector | 59 |
| Connecting a Device Equipped with VISCA RS- 232C Connector | 59 |
| Connecting a Device Equipped with VISCA RS- 422 Connector | 60 |
| Connecting a Video Monitor Equipped with Analog RGB/Component Connectors | 61 |
| Connecting a Video Monitor, VTR, etc. Equipped with Composite Video Input Connector | 61 |
| Connecting a VTR Equipped with SDI Input Connector | 62 |
| Connecting a VTR Equipped with HD-SDI Input Connectors | 62 |
| Connecting a Computer | 63 |
| Connecting the BRU-H700 HD Optical Multiplex Unit | 63 |
| Connecting a Video Switcher | 64 |
| Connecting a Sync Signal Generator | 65 |

Appendix

| | |
|--|------------|
| List of Messages | 67 |
| Troubleshooting | 68 |
| Menu Configuration | 70 |
| Presetting Items | 74 |
| Specifications | 76 |
| Dimensions | 77 |
| Pin Assignments | 80 |
| Wiring Diagram of VISCA RS-422 Connection | 83 |
| Using the VISCA RS-422 Connector Plug | Back cover |

Precautions

Operating or storage location

Operating or storing the camera in the following locations may cause damage to the camera:

- Extremely hot or cold places (Operating temperature: 0°C to 40°C [32°F to 104°F])
- Exposed in direct sunlight for a long time, or close to heating equipment (e.g., near heaters)
- Close to sources of strong magnetism
- Close to sources of powerful electromagnetic radiation, such as radios or TV transmitters
- Locations subject to strong vibration or shock

Ventilation

To prevent heat buildup, do not block air circulation around the camera.

Transportation

When transporting the camera, repack it as originally packed at the factory or in materials equal in quality.

Cleaning

- Use a blower to remove dust from the lens or optical filter.
- Use a soft, dry cloth to clean the external surfaces of the camera. Stubborn stains can be removed using a soft cloth dampened with a small quantity of detergent solution, then wipe dry.
- Do not use volatile solvents such as alcohol, benzene or thinners as they may damage the surface finishes.

Maintenance

The camera mechanism may cause abnormal noise due to wear and lubrication loss after a long period of use. To maintain optimum performance, we recommend periodical maintenance. If abnormal noise occurs, consult with your Sony dealer.

Note on laser beams

Laser beams may damage a CCD. You are cautioned that the surface of a CCD should not be exposed to laser beam radiation in an environment where a laser beam device is used.

Phenomena Specific to CCD Image Sensors

The following phenomena that may appear in images are specific to CCD (Charge Coupled Device) image sensors. They do not indicate malfunctions.

White flecks

Although the CCD image sensors are produced with high-precision technologies, fine white flecks may be generated on the screen in rare cases, caused by cosmic rays, etc. This is related to the principle of CCD image sensors and is not a malfunction.

White flecks tend to be seen particularly in the following cases:

- during operation at a high environmental temperature
- when you have raised the gain (sensitivity)

This symptom may be improved by turning the camera off and then on again.

Vertical smear

When an extremely bright object, such as a strong spotlight or flashlight, is being shot, vertical tails may be produced on the screen, or the image may be distorted.

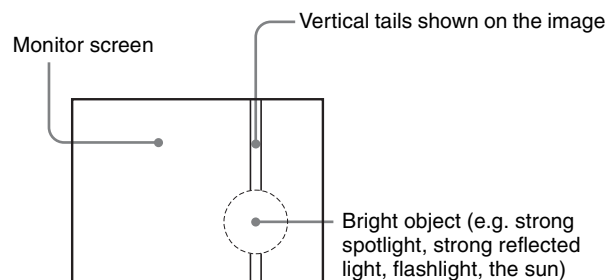

Aliasing

When fine patterns, stripes, or lines are shot, they may appear jagged or flicker.

Features

Compact, HD 3CCD video camera with built-in pan/tilt/zoom functions

- The camera integrates the HD 3CCD camera block, pan/tilt mechanism, and 12-magnification optical zoom with 4-magnification digital zoom in a compact body. The compactness and integration allow the camera versatile usage.
- The camera is provided with a wide-angle pan/tilt mechanism of $\pm 170^\circ$ horizontally, 90° upward and 30° downward, which enables wide-range remote shooting.
- The new pan/tilt mechanism enabling smooth camera movement even at low speed realizes a minimum pan/tilt speed of 0.25° per second.
- The pan/tilt mechanism is remarkably quiet, even at the maximum pan/tilt speed of 60° per second.

HD CCD camera with high image quality and high-resolution remote shooting

- The HD 3CCD camera system uses three 1/3-type HD CCDs containing a total of 1,120,000 picture elements that can shoot high-definition images to offer superior picture quality with high sensitivity and lower smear level.
- Shooting an image using the 1080i (effective interlaced scanning: 1080 lines) high-definition format, which is equivalent to the HDTV broadcast, is enabled. The HD format can be switched (1080/59.94i or 1080/50i) with the switch on the camera.
- A volume of information of four times the capacity of a normal TV broadcast (effective scanning: 480 lines) and camera image shot in 16:9 aspect ratio provides a theater-like wide screen picture.

Excellent optical performance allowing superior quality shooting

- Adoption of Carl Zeiss Vario-Sonnar $\text{\textcircled{R}}$ T* lens with an aperture of 72 mm reduces chromatic aberration and achieves high-resolution at all corners of an image.
- Use of the multi-reflection reduction coating minimizes unnecessary light reflection inside the lens and significantly reduces flare and ghost to provide a realistic image with high contrast and superior color reproduction.
- The lens has a focal length of 32.5 mm to 390 mm (equivalent to a 35-mm camera). The wider zooming

range enables remote shooting of high-definition images with an aspect ratio of 16:9.

- Adoption of a 12-magnification optical zoom lens that enables zooming without deterioration in picture quality allows realistic high-definition images. Even when you shoot a subject using maximum magnification, clear images with minimum aberration can be obtained by a lens system that consists of 16 lenses of 11 groups containing three aspherical lenses.
- The camera is equipped with an optical active lens system that provides a picture blur compensation function to prevent deterioration in the quality. The lens itself moves up, down, left and right to compensate immediately for the blur of an optical axis. Three compensation effects are selectable according to shooting conditions.

Built-in interface card slot

The camera is equipped with an interface card slot for the optional HFBK-HD1 HD Interface Board, HFBK-SD1 SD Interface Board, HFBK-XG1 XGA Interface Board, HFBK-ST1 HDV Interface Board and BRBK-H700 HD Optical Multiplex Card. Use of these interface boards gives the camera the capability of having various image output formats.

Long-distance image transmission and pan/tilt/zoom control

- Combined use of the BRBK-H700 HD Optical Multiplex Card, CCFC-M100HG Optical Fiber Cable and BRU-H700 Optical Multiplex Unit, and Sony's unique camera connection technology and optical digital multiplex transmission technology allows short to long distance (up to 1,000 m, or 3,281 feet) transmission of camera images and pan/tilt/zoom control signals. Use of the optical fiber cable enables an economical and easy system configuration for long distance.
- The supplied ceiling brackets allow installation of the camera on a ceiling or a shelf, etc. in a high position.

VISCA camera protocol supported

- The camera is equipped with both RS-232C and RS-422 communication interfaces. As the camera supports the industry-standard VISCA camera protocol, up to 7 cameras can be connected and remotely controlled at a high communication speed of 38,400 bps.
- The optional RM-BR300 Remote Control Unit allows easy camera operations.

External video sync function

The camera is equipped with an external video sync function to synchronize the camera images on multiple cameras. The camera also has an analog component/RGB output connector as standard equipment.

Tally lamp

The tally lamp of the camera allows you to make sure it is selected at a glance.

Mounted circuit board using lead-free solder

Lead-free solder is used for the circuit boards of the camera for environmental reasons.

System Components

In order to support multiple system configurations, a variety of optional products are available for the BRC-H700 HD 3CCD Color Video Camera. This section introduces these optional products as well as the accessories supplied with the camera.

Supplied Components and Accessories

Before using the camera, make sure you have the following components and accessories supplied.

Camera (1)

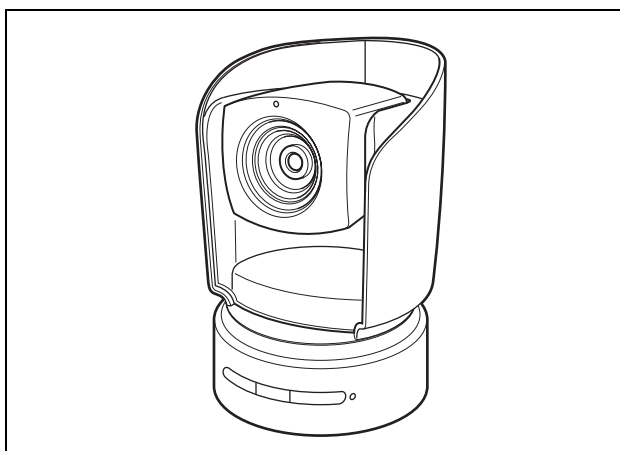

AC power adaptor MPA-AC1 (Sony) (1)

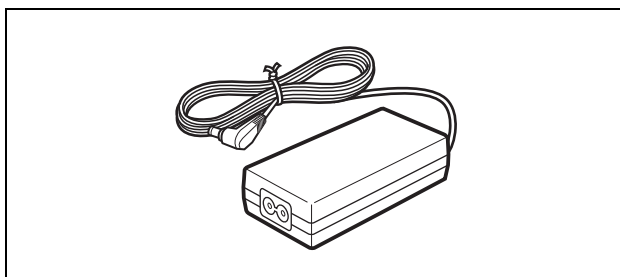

AC power cord (1)

USA and Canadian model

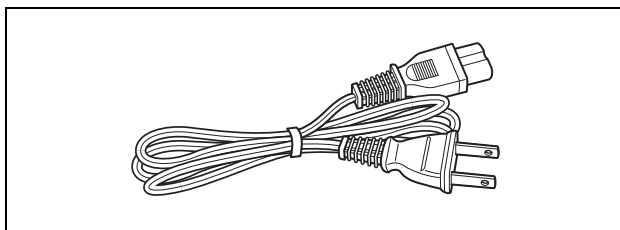

European model

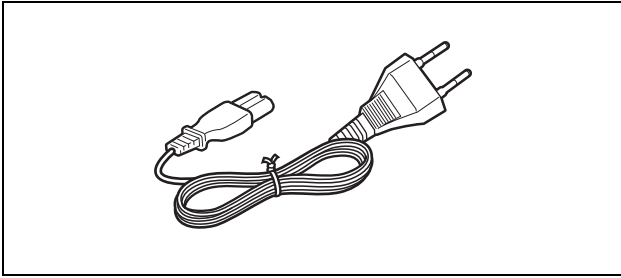

Remote commander (1)

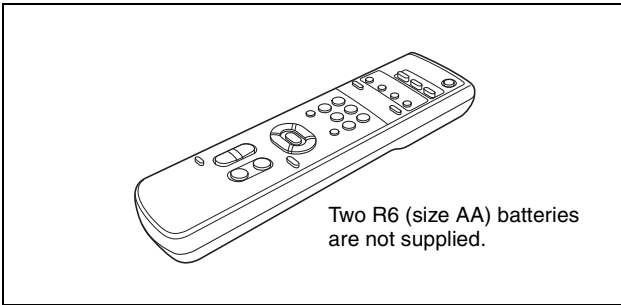

Ceiling bracket (A) (1)

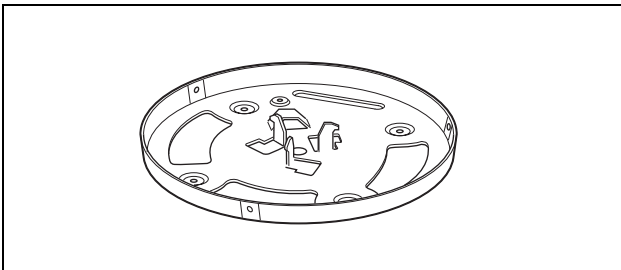

Ceiling bracket (B) (1)

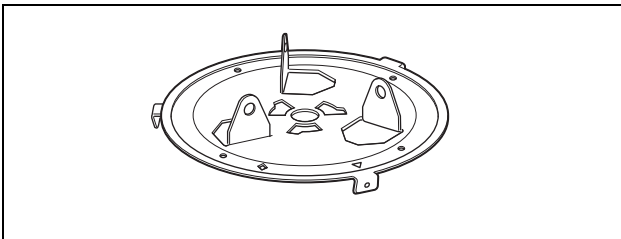

Wire rope (1)

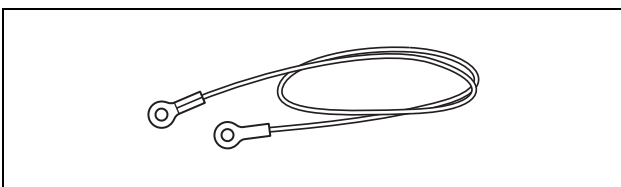

Screw \oplus M3 \times 8 (7)/Stainless screw \oplus M4 \times 8 (1)

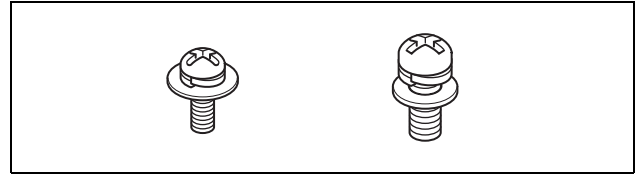

RS-422 connector plug (1)

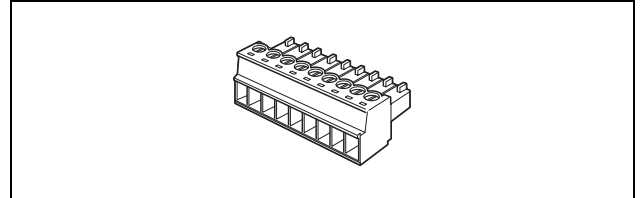

Operating Instructions (1)

Optional Products

RM-BR300 Remote Control Unit

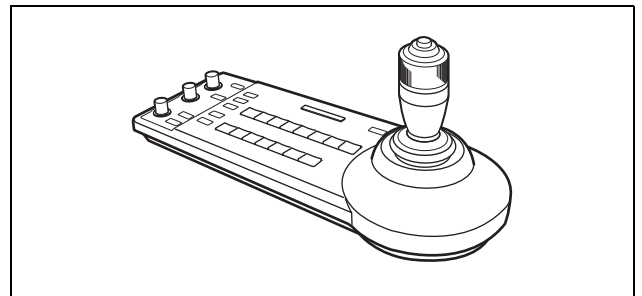

The joystick of the remote control unit allows you comfortable pan/tilt and zoom operations. The remote control unit also allows remote operation of up to seven cameras.

Supplied accessories: AC power adaptor (1), AC power cord (1), RS-232C connecting cable (3 m) (1), RS-422 connector plug (2)

BRU-H700 HD Optical Multiplex Unit

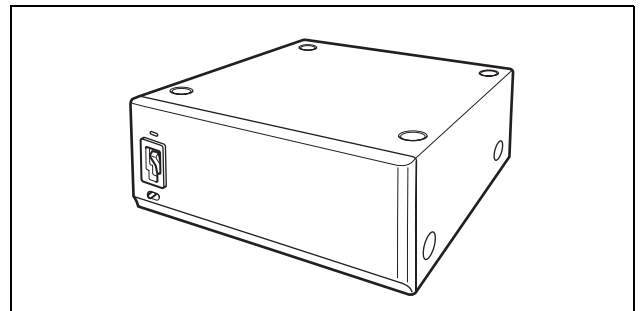

The HD Optical Multiplex Unit allows a connection up to of 1,000 m (3,281 feet) using the CCFC-M100HG 2-core optical fiber cable.

Supplied accessories: AC power cord (1), RS-232C connecting cable (3 m) (1), RS-422 connector plug (1)

CCFC-M100HG Optical Fiber Cable

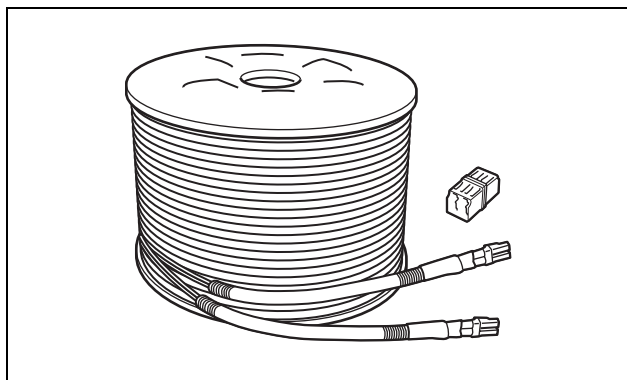

This is a 2-core multi-mode optical fiber cable of 100 m (328 feet) long.
 Supplied accessories: extension plug

HFBK-SD1 SD Interface Board

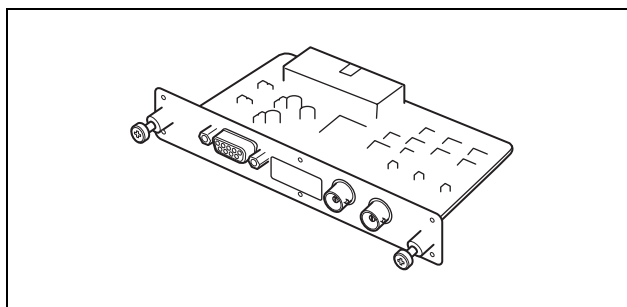

Insert the board into the camera or the HD Optical Multiplex Unit to allow output of an analog video signal such as the composite video, S video, component video and RGB signals, or a down-converted SD-SDI signal. An audio signal of the SD-SDI signal is not output from the board.

HFBK-HD1 HD Interface Board

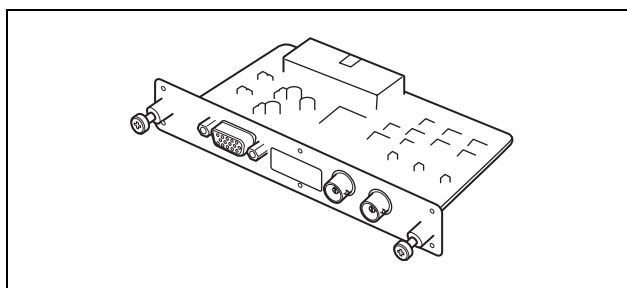

Insert the board into the camera or the HD Optical Multiplex Unit to allow output of an HD-SDI signal conforming to SMPTE292M serial digital interface standards, or output of an analog video signal (component/RGB).
 An audio signal of the HD-SDI signal is not output from the board.

HFBK-XG1 XGA Interface Board

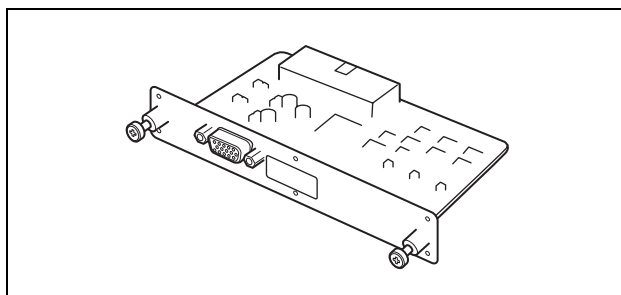

Insert the board into the camera or the HD Optical Multiplex Unit to allow output of a signal conforming to the VESA standards (VGA, XGA or WXGA).

HFBK-TS1 HDV Interface Board

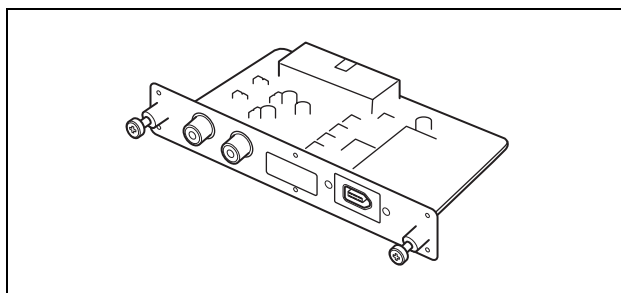

Insert the board into the camera or the HD Optical Multiplex Unit to allow conversion of the video signal from the camera and the input audio signal into the signal conforming to the HDV standards.

BRBK-H700 HD Optical Multiplex Card

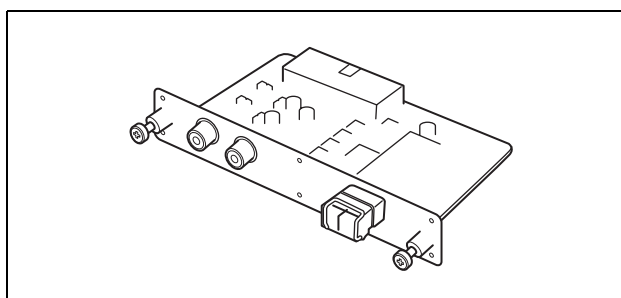

Insert the card into the camera to allow high-bit multiplex transfer via optical fiber cable (video, audio, external video sync and control signals).

Video Switcher (commercially available)

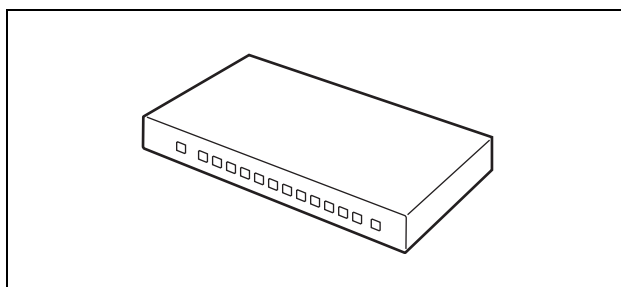

It switches the video signal input of multiple cameras.

System Configuration

The BRC-H700 HD 3CCD Color Video Camera has various system configuration capabilities using optional products. This section describes nine typical system examples with the required components and the main usage of each system.

Operating a BRC-H700 Camera Using the Supplied Remote Commander

This system allows you:

To operate the camera readily from a short distance

System configuration

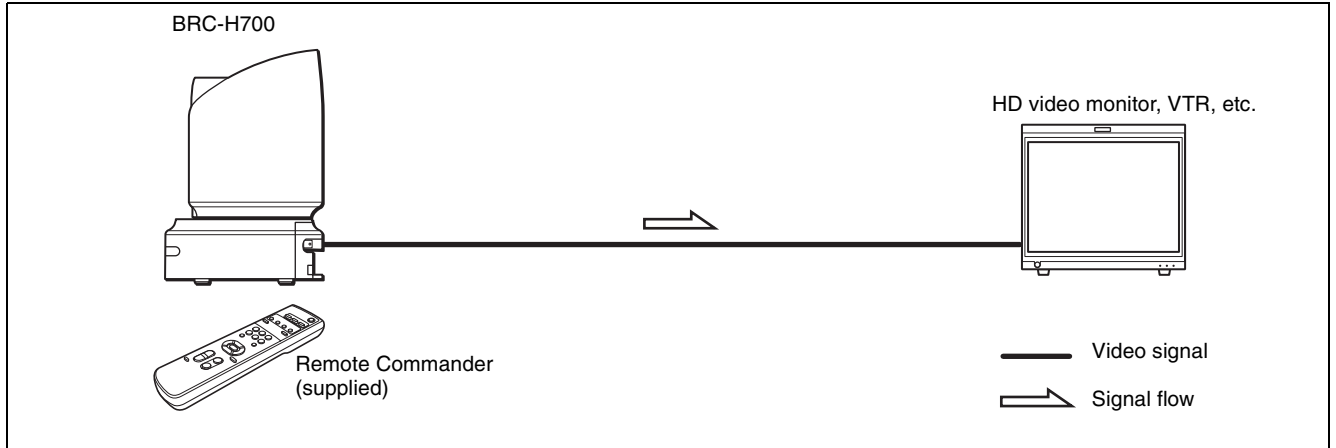

Operating a BRC-H700 Camera Using the RM-BR300 Remote Control Unit

This system allows you:

To perform pan/tilt and zoom operations comfortably using the joystick of the Remote Control Unit

System configuration

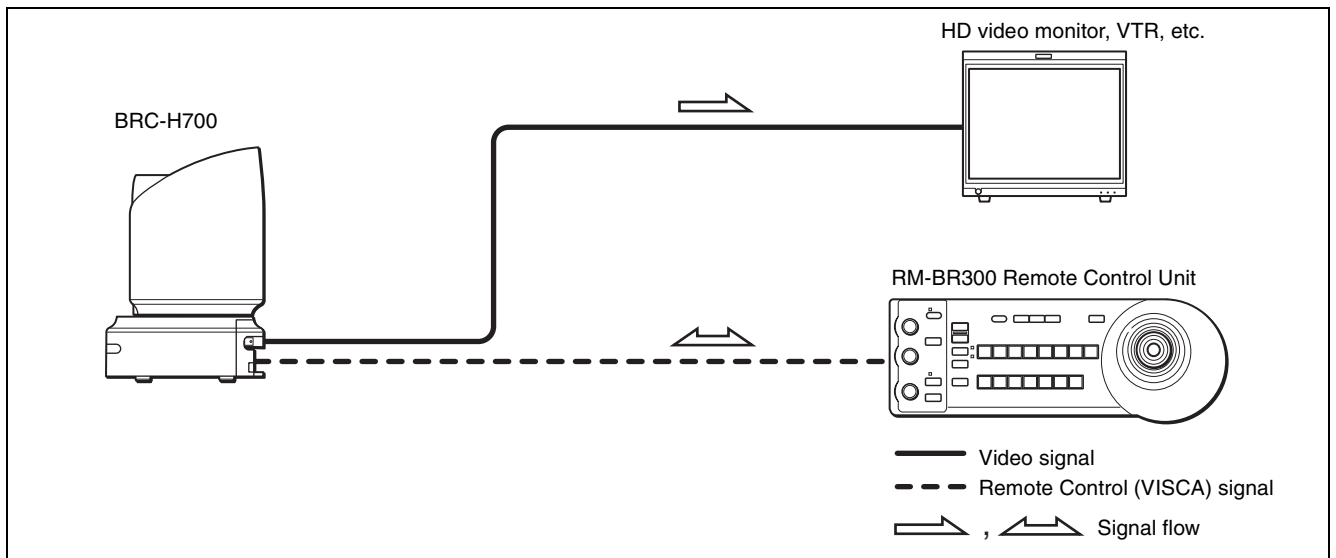

Operating Multiple BRC-H700 Cameras Using the RM-BR300 Remote Control Unit

This system allows you:

- To operate up to seven cameras remotely using a single Remote Control Unit
- To perform pan/tilt and zoom operations comfortably using the joystick

System configuration

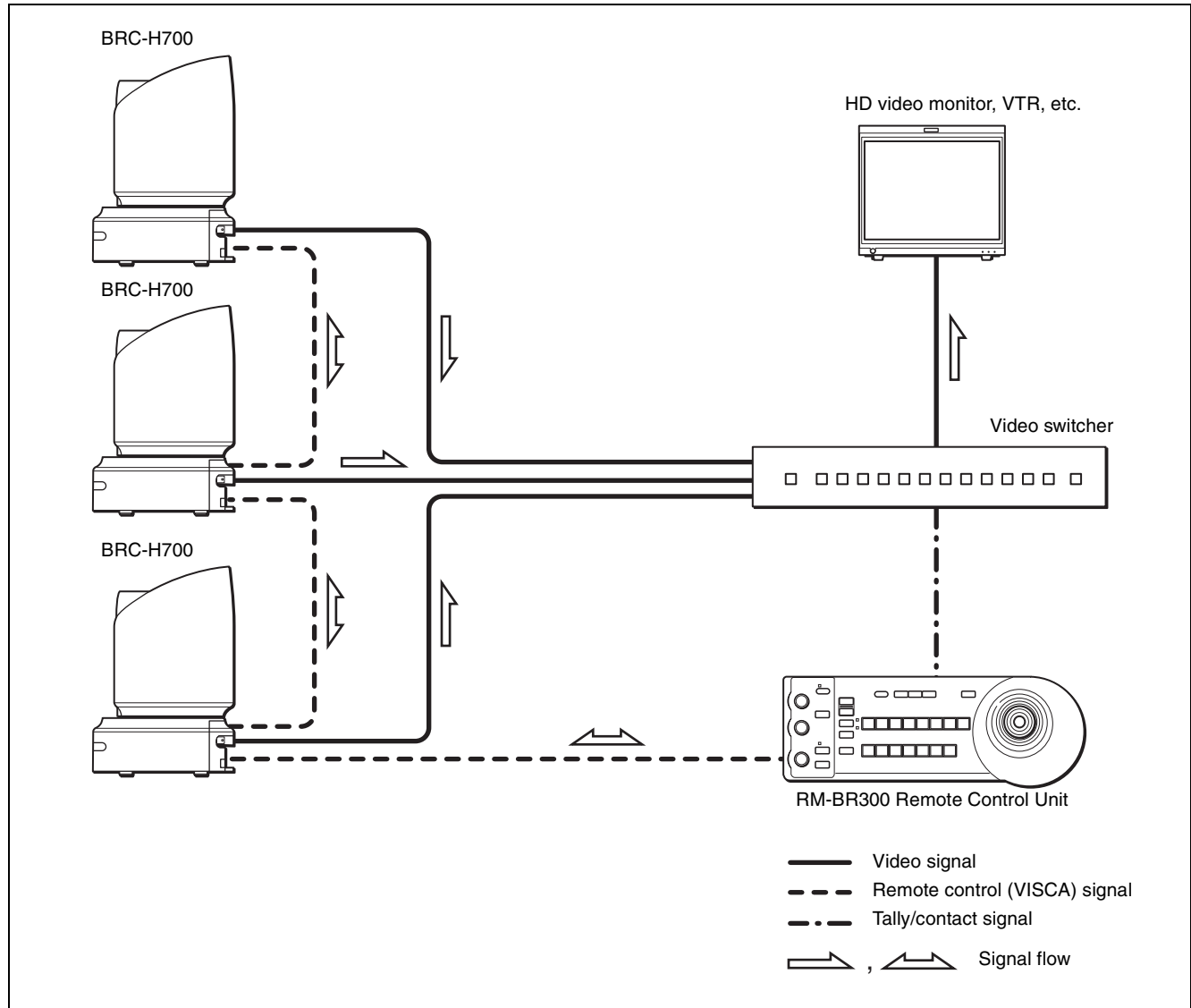

Operating a BRC-H700 Camera from a Long Distance

This system allows you:

- To operate the camera remotely from a distance up to 1,000 m (3,281 feet)
- To perform pan/tilt and zoom operations comfortably using the joystick
- To transmit the video signal and control signal of the camera to a distant place using the Optical Fiber Cable

System configuration

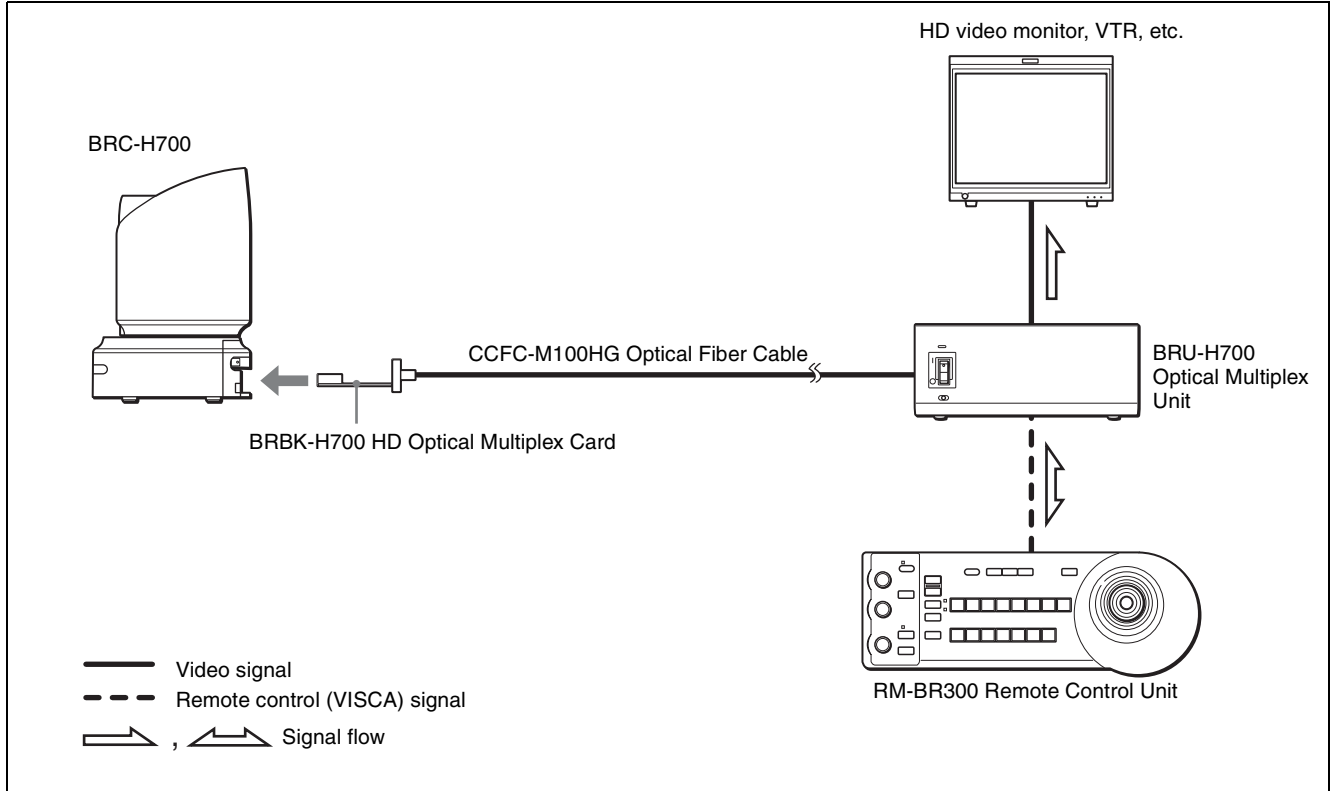

Notes

- Be sure to turn on the power of the BRC-H700 camera before you turn on the power of the BRU-H700 HD Optical Multiplex Unit.
- The BRC-H700 camera does not operate if nothing is connected to the BRBK-H700 HD Optical Multiplex Card inserted into the camera. To operate the camera, connect the BRU-H700 Optical Multiplex Unit to the BRBK-H700 using the CCFC-M100HG Optical Fiber Cable and turn on the power of the BRU-H700.
- When the BRBK-H700 HD Optical Multiplex Card is inserted into the BRC-H700 camera, the EXT SYNC IN connector, VISCA RS-232C IN/OUT connectors and VISCA RS-422 connector on the rear of the camera and the BOTTOM switches on the bottom of the camera are disabled. Use the connectors and switches on the rear of the BRU-H700 Optical Multiplex Unit instead.
- The optional CCFC-M100 Optical Fiber Cable cannot be used with this system.

Operating Multiple BRC-H700 Cameras from a Long Distance

This system allows you:

- To operate up to seven cameras remotely from a distance up to 1,000 m (3,281 feet)
- To perform pan/tilt and zoom operations comfortably using the joystick
- To transmit the video signal and control signal of the cameras to a distant place using the Optical Fiber Cable

System configuration

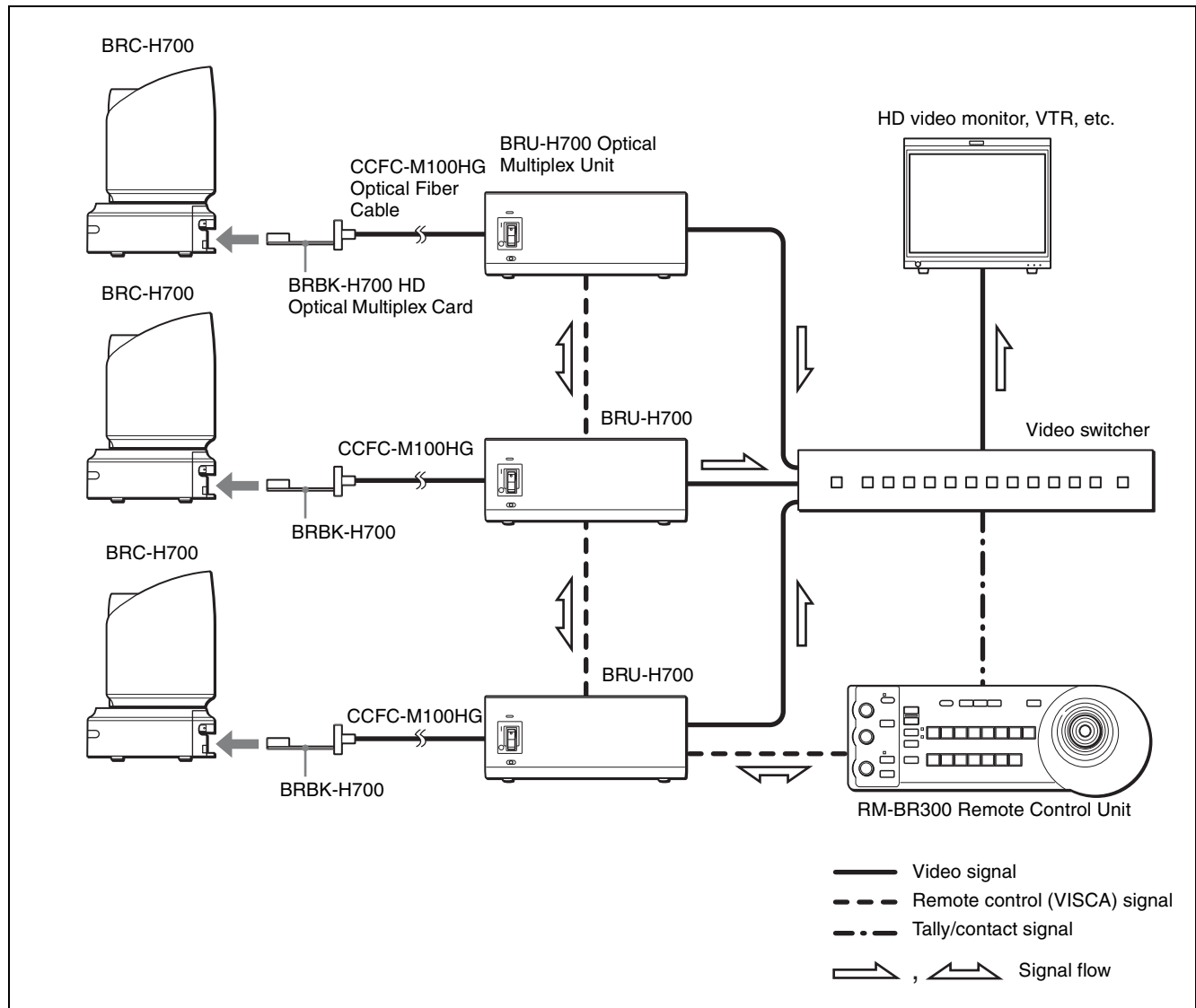

Using BRC-H700 Cameras and VISCA-controllable Cameras in the Same System

This system allows you:

- To operate up to seven cameras supporting the VISCA protocol such as EVI-D30/D30P, EVI-D70/D70P, EVI-D100/D100P and BRC-300/300P remotely using a single RM-BR300 Remote Control Unit
- To perform pan/tilt and zoom operations comfortably using the joystick
- To control the BRC-H700 cameras remotely from a distance up to 1,000 m (3,281 feet) by transmitting the video signal and control signal using the Optical Fiber Cable

System configuration

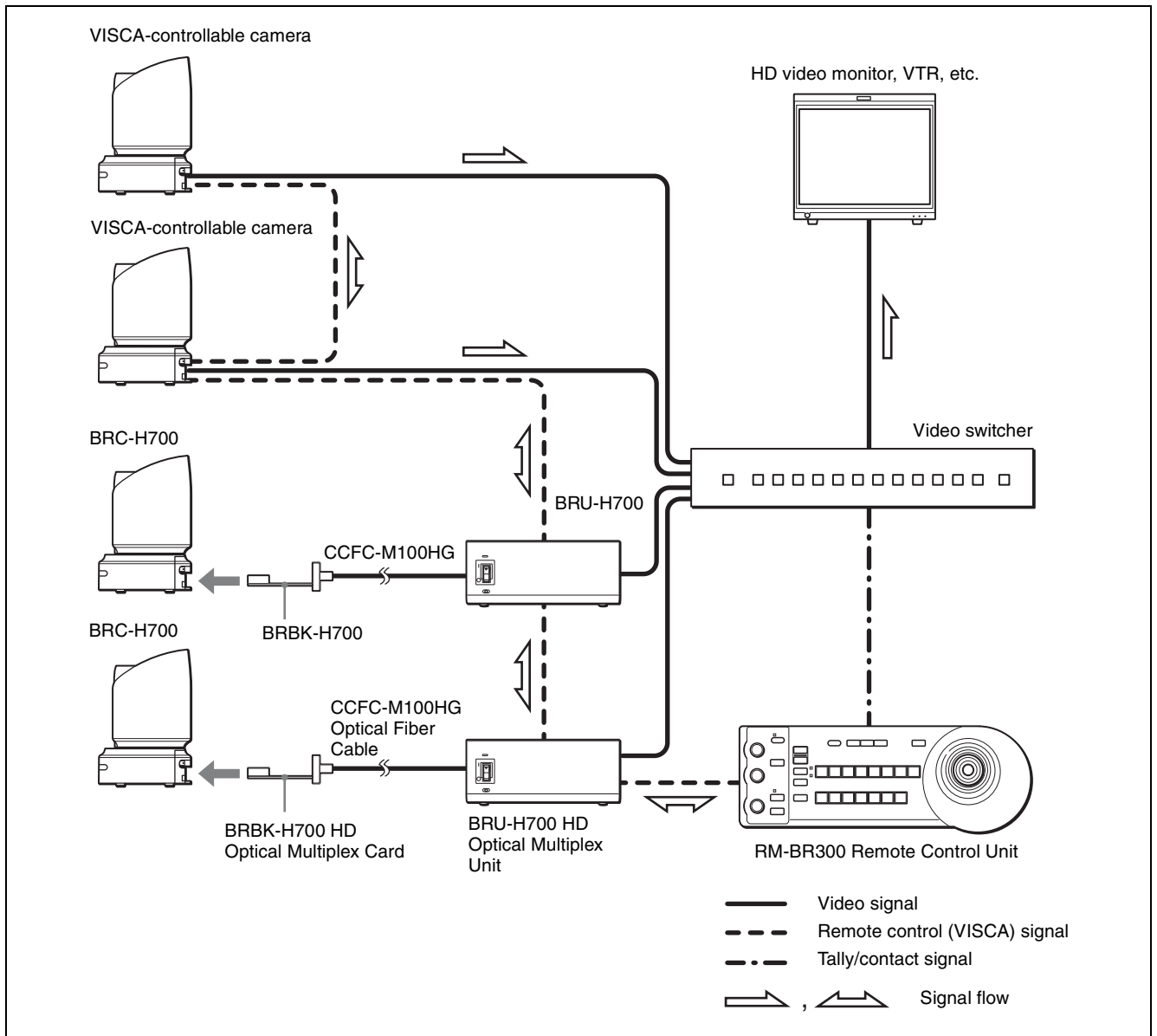

Transmitting Audio Signals Using the BRU-H700

This system allows you:

- To operate the camera remotely from a distance up to 1,000m (3,281 feet)
- To perform pan/tilt and zoom operations comfortably using the joystick
- To transmit the video signal and control signal of the camera, and the audio signal input to the BRBK-H700 Optical Multiplex Card to a distant place using the Optical Fiber Cable

System configuration

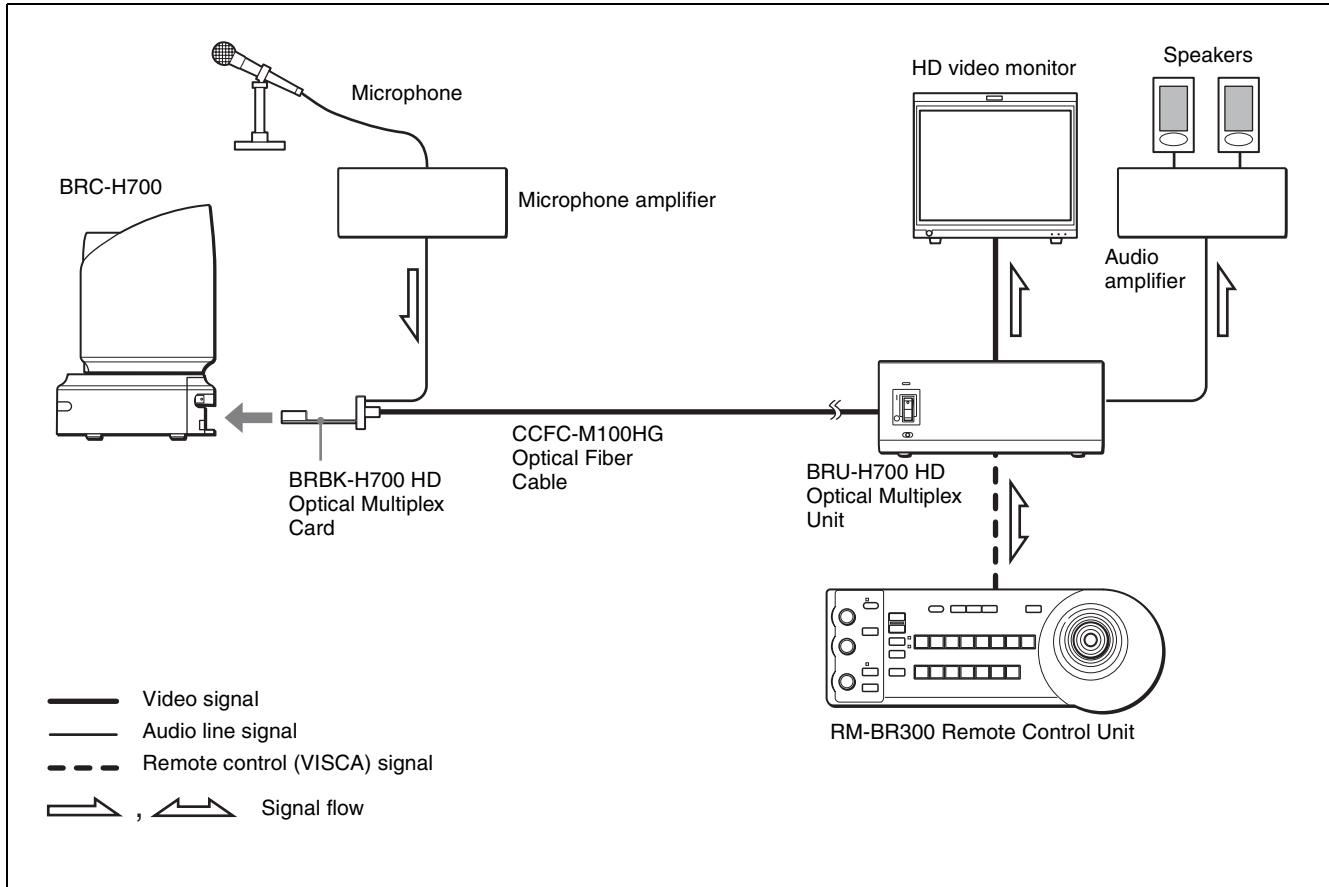

Using the HFBK-TS1 HDV Interface Board to Input the Video and Audio Signals Mixed to the HDV Video Equipment

This system allows you:

- To input the video signal of the camera to the HDV video equipment
- To input the video signal of the camera and the audio signal via the HFBK-TS1 HDV Interface Board simultaneously to the HDV video equipment
- To perform pan/tilt and zoom operations comfortably using the joystick

System configuration

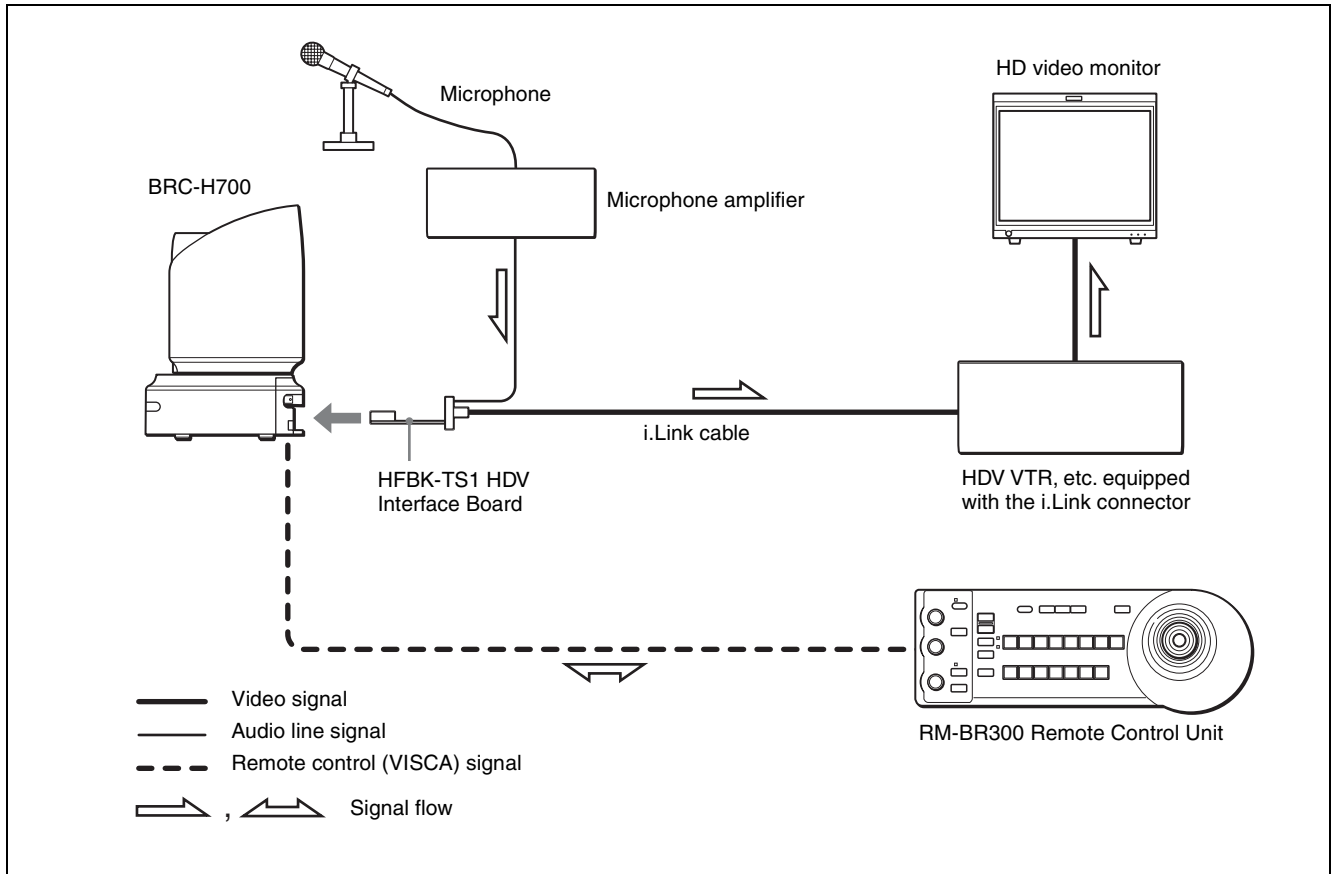

Notes

- You cannot operate pan/tilt and zoom with HDV video equipment connected to the i.LINK (HDV) OUT connector on the HFBK-TS1 HDV Interface Board. Use the VISCA RS-232C or VISCA RS-422 connectors instead.
- Use **AUDIO DELAY** in the HDV menu of the camera to compensate for the delay between the video signal of the camera and the audio signal input to the HFBK-TS1 HDV Interface Board (see page 26). The delay is adjustable by **STEP** (approx. 24 mS).

Transmitting the Audio Signal Using the BRBK-H700 HD Optical Multiplex Card and the HFBK-TS1 HDV Interface Board

This system allows you:

- To operate the camera remotely from a distance up to 1,000m (3,281 feet)
- To perform pan/tilt and zoom operations comfortably using the joystick
- To transmit the video signal and control signal of the camera, and the audio signal input to the BRBK-H700 Optical Multiplex Card to a distant place using the Optical Fiber Cable
- To output the audio signal transmitted via the Optical Fiber Cable as an audio signal conforming to HDV standards from the HFBK-TS1 through the AUDIO OUT jacks on the BRU-H700 if you insert the HFBK-TS1 HDV Interface Board into the BRU-H700

System configuration

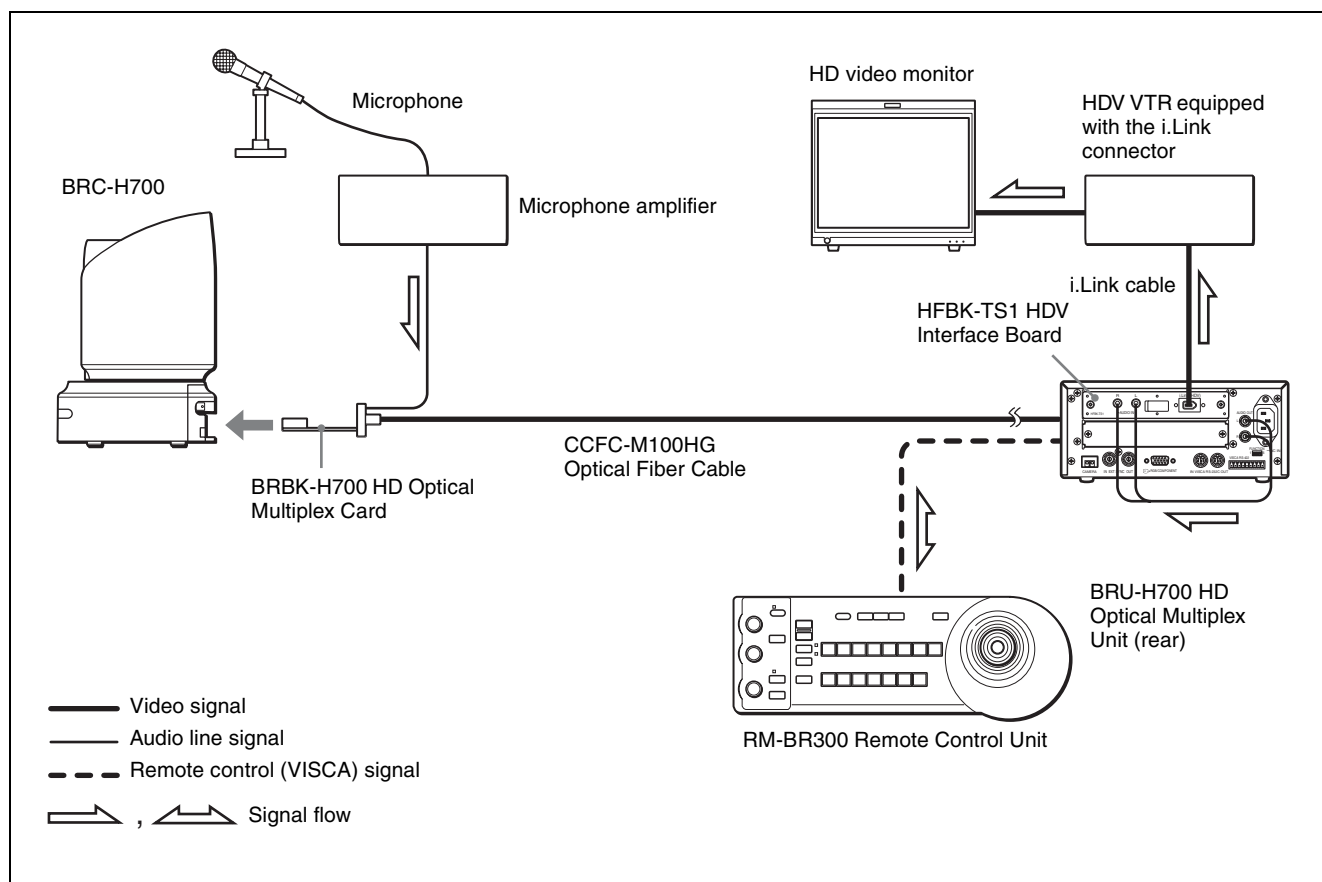

Note

The video signal delay in this system is caused by signal processing in the HFBK-TS1 HDV Interface Board. If you are uncomfortable with the delay, output the video signal via the RGB/COMPONENT connector on the BRU-H700.

Location and Function of Parts

Camera

Front

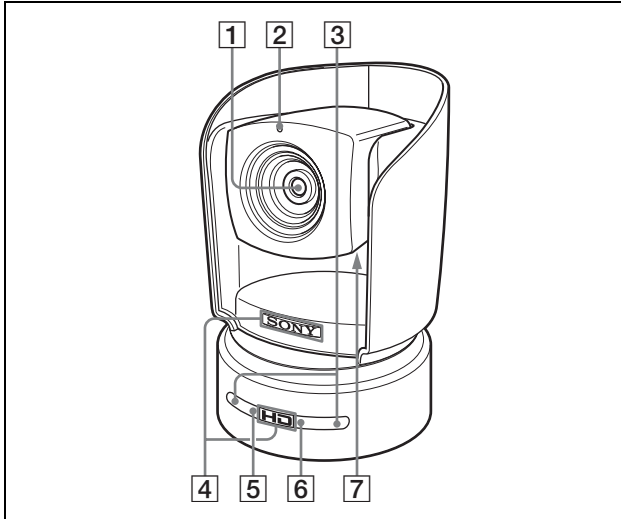

- 1 Lens**
This is a 12-magnification optical zoom lens.
Note
You cannot perform pan/tilt operation with a wide or telephoto conversion lens attached.
- 2 Tally lamp**
Lights in red when a VISCA tally command is received or the camera is selected by the RM-BR300 Remote Control Unit (not supplied). Flashes at intervals of about 0.5 seconds if the rotating speed of the cooling fan motor is lowered or the motor has stopped regardless of on/off of the tally lamp.
- 3 Remote sensor**
This is the sensor for the supplied Remote Commander.
- 4 SONY and HD nameplates**
Pull them out to turn them over and attach upside down if necessary.
- 5 POWER lamp**
Lights when the camera is connected to an AC outlet using the supplied AC power adaptor and AC power cord. Flashes in green when the camera receives an operation command from the supplied Remote Commander.

- 6 STANDBY lamp**
Lights when the camera is turned off using the Remote Commander.
- 7 ND filter select switch (bottom of the camera block)**
Switches the setting of the built-in ND filter according to the brightness of the subject to be shot. For details, see “Using the ND Filter” on page 31.

Rear

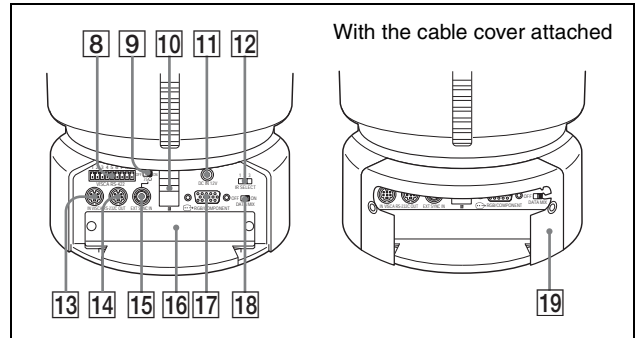

- 8 VISCA RS-422 connector**
Used for VISCA control.

For connection to the VISCA RS-422 connector, see “Using the VISCA RS-422 Connector Plug” on back cover.
- 9 75-ohm termination switch**
This switch is used when an external sync signal is used. Set it to OFF when this camera is in the middle of a daisy chain connection of multiple cameras. Set it to ON when the camera is at the end of a daisy chain connection.
- 10 Remote sensor**
This is the sensor for the supplied Remote Commander.
- 11 DC IN 12V connector**
Connect the supplied AC power adaptor.
- 12 IR SELECT switch**
Select the camera number when you operate multiple cameras with the same Remote Commander.
- 13 VISCA RS-232C IN connector**
Connect to the RM-BR300 Remote Control Unit (not supplied). When you connect multiple cameras, connect it to the VISCA RS-232C OUT connector of the previous camera in the daisy chain connection.
- 14 VISCA RS-232C OUT connector**
When you connect multiple cameras, connect it to the VISCA RS-232C IN connector of the next camera in the daisy chain connection.

- 15 EXT SYNC IN connector**
Accepts external video sync signals.
- 16 Card slot**
Insert an optional interface board, HFBK-HD1, HFBK-SD1, HFBK-XG1, HFBK-TS1 or BRBK-H700.
The slot cover is attached to the camera at the factory.
- 17  RGB/COMPONENT connector**
Supplies the images as analog component (YPbPr or RGB) signal.
- 18 DATA MIX switch**
Set the switch to ON to overlap the menu with the video signal output from the installed interface board. Set it to OFF not to overlap the menu.
- 19 Cable cover**
The cable cover is attached to the camera at the factory. To remove the cable cover, see page 50.

Note

Do not carry the camera by holding the cable cover. Otherwise, the cable cover may come off and the camera may fall.

Bottom

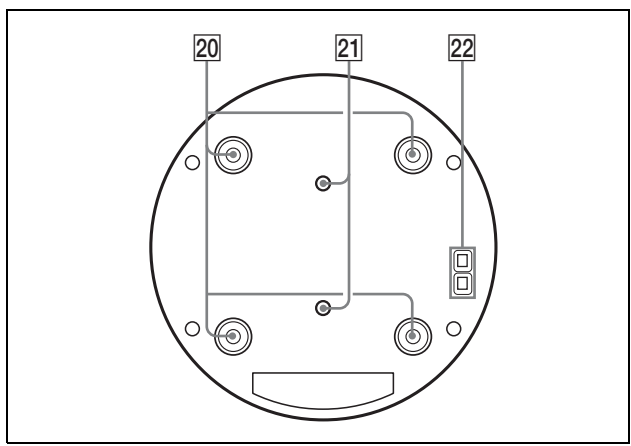

- 20 Ceiling bracket mounting screw holes**
When you install the camera to the ceiling or on a shelf, etc. in a high position, secure the supplied ceiling bracket to these holes using the supplied four screws. The four feet are attached to the holes at the factory.

For installation, see “Installing the Camera in a High Position” on page 52.
- 21 Tripod screw holes (1/4-20UNC)**
When you install the camera to a tripod, secure the tripod to these holes.

- 22 BOTTOM switches**
Used for the output signal format selection, RS-232C/RS-422 selection, baud rate selection, remote control signal output on/off and camera address setting.

For details, see “Setting of the BOTTOM switches” on page 19.

Setting of the BOTTOM switches

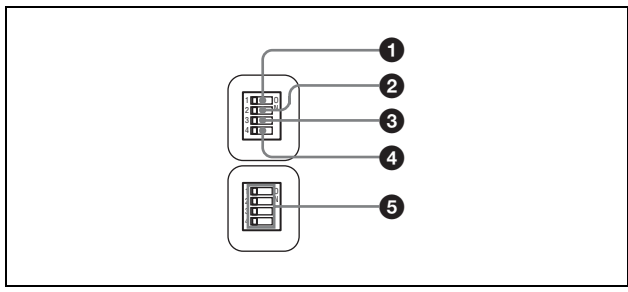

- 1 Switch 1 (59.94i/50i signal format selector)**
Set to ON for output of 50i signal format, or OFF for output of 59.94i signal format.
- 2 Switch 2 (RS-232C/RS-422 selector)**
Set to ON for RS-422, or OFF for RS-232C.
- 3 Switch 3 (Communication baud rate selector)**
Set to ON for 38400bps, or OFF for 9600bps.
- 4 Switch 4 (Infrared signal output switch)**
Set to ON to enable an infrared signal output, or OFF to disable the output.
- 5 Camera address selectors**
Set the address of the camera.
Normally set to “0”. With this setting, addresses are assigned to the cameras automatically in the connected order by pressing the POWER button while holding down the RESET button on the RM-BR300 Remote Control Unit.
You can assign the camera address “1” to “7” manually by setting these selectors as follows:

| Camera address | 0 | 1 | 2 | 3 | 4 | 5 | 6 | 7 |
|----------------|-----|-----|-----|-----|-----|-----|-----|----|
| Switch 1 | OFF | ON | OFF | ON | OFF | ON | OFF | ON |
| Switch 2 | OFF | OFF | ON | ON | OFF | OFF | ON | ON |
| Switch 3 | OFF | OFF | OFF | OFF | ON | ON | ON | ON |

Switch 4 is not used.

Note

Set the switches before you turn on the power of the camera.

Remote Commander (supplied)

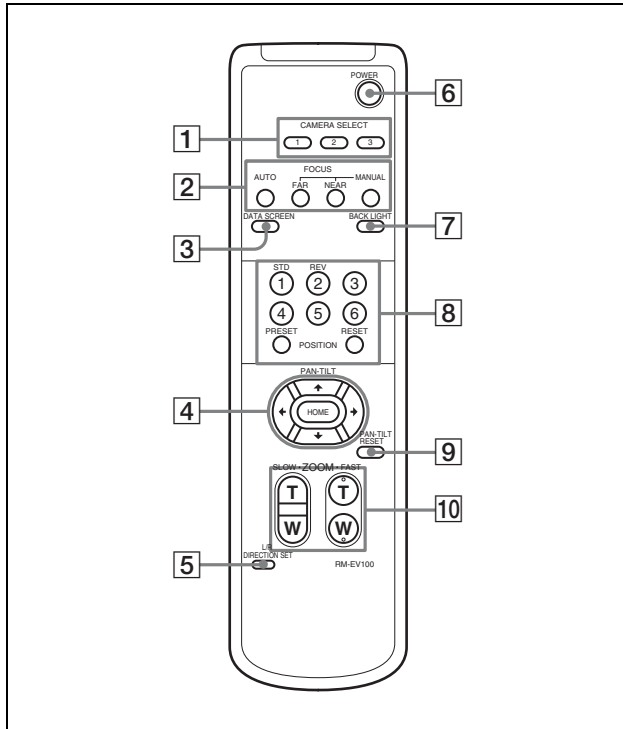

- 1 CAMERA SELECT buttons**
Press the button corresponding to the camera you want to operate with the Remote Commander. The camera number can be set using the IR SELECT switch on the rear of the camera.

Note

If two or more cameras are adjacent and have the same camera number, they are operated simultaneously with the same Remote Commander. When you install the cameras close to each other, set different camera numbers.

For the camera number setting, see “Operating Multiple Cameras with the Remote Commander” on page 40.

- 2 FOCUS buttons**
Used for focus adjustment.
Press the AUTO button to adjust the focus automatically. To adjust the focus manually, press the MANUAL button, and adjust it with the FAR and NEAR buttons.

- 3 DATA SCREEN button**
Press this button to display the main menu. Press it again to turn off the menu. If you press the button when a lower-level menu is selected, the display goes back to a higher-level menu.

Note

Pan/tilt and zoom operations are disabled when the menu is displayed.

- 4 PAN-TILT buttons**
Press the arrow buttons to perform panning and tilting. Press the HOME button to face the camera back to the front.
When the menu is displayed, use \uparrow or \downarrow to select the menu items and \leftarrow or \rightarrow to change the set values.
- 5 L/R DIRECTION SET button**
Hold down this button and press the REV button to change the direction of the camera movement opposite to that indicated by the arrow of the \leftarrow/\rightarrow buttons.
To reset the direction of the camera movement, press the STD button while holding down this button.
- 6 POWER switch**
Press this button to turn on/off the camera when the camera is connected to an AC outlet.
- 7 BACK LIGHT button**
Press this button to enable the backlight compensation. Press it again to disable the backlight compensation.
- 8 POSITION buttons**
Hold down the PRESET button and press button 1 to 6 to store the current camera direction, zooming, focus adjustment and backlight compensation in the memory of the pressed number button. To erase the memory contents, hold down the RESET button and press button 1 to 6.
- 9 PAN-TILT RESET button**
Press this button to reset the pan/tilt position.
- 10 ZOOM buttons**
Use the SLOW button to zoom slowly, and the FAST button to zoom quickly.
Press the T (telephoto) side of the button to zoom in, and the W (wide angle) side to zoom out.

Installing batteries

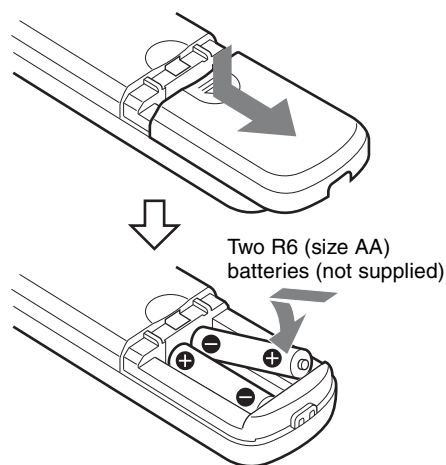

Caution

To avoid risk of explosion, use R6 (size AA) manganese or alkaline batteries.

RM-BR300 Remote Control Unit (not supplied)

This manual explains the operations of the RM-BR300 Remote Control Unit when it is used with BRC-H700 cameras.

For operations with other cameras, refer to the Operating Instructions supplied with the RM-BR300.

Front

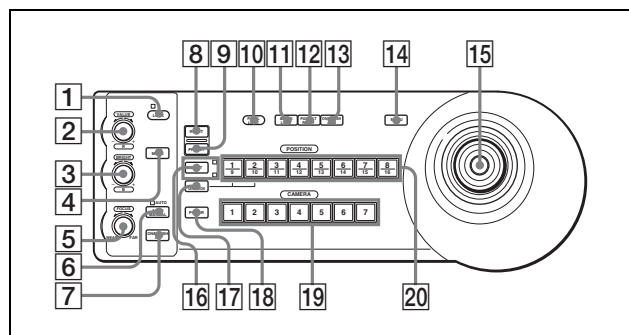

1 LOCK button and indicator

Press the LOCK button for more than one second, and the LOCK indicator lights and the values set by the VALUE/R, BRIGHT/B and FOCUS controls are locked. (The indicators of the locked controls are turned off.) The AUTO/MANUAL button is also disabled.

Press the LOCK button for more than one second again to unlock the controls and buttons.

2 VALUE/R control

When the brightness adjustment mode is selected with the MODE button (with the VALUE indicator lit):

Adjusts the value of the item (SHUTTER, IRIS or GAIN) selected with the menu of the camera.

When the VALUE indicator is lit, the function of the control varies according to the MODE setting in the EXPOSURE menu of the camera. For details, see “Functions of the VALUE and BRIGHT controls” on page 47.

When the white balance adjustment mode is selected with the MODE button (with the R indicator lit):

The function of the control with the R indicator lit varies according to the white balance mode selected on the camera. For details, see “Functions of the R and B controls” on page 47.

3 BRIGHT/B control

When the brightness adjustment mode is selected with the MODE button (with the BRIGHT indicator lit):

Adjusts the value of the brightness of the camera, etc.

When the BRIGHT indicator is lit, the function of the control varies according to the MODE setting in the EXPOSURE menu of the camera. For details, see “Functions of the VALUE and BRIGHT controls” on page 47.

When the white balance adjustment mode is selected with the MODE button (with the B indicator lit):

The function of the control with the B indicator lit varies according to the white balance mode selected on the camera. For details, see “Functions of the R and B controls” on page 47.

4 MODE button

Press this button to select the function of the VALUE/R control and BRIGHT/B control.

When the brightness adjustment mode is selected, the VALUE and BRIGHT indicators are lit.

When the white balance adjustment mode is selected, the R and B indicators are lit.

5 FOCUS control

Turn this control counterclockwise (toward NEAR) to focus on a near subject, and clockwise (toward FAR) to focus on a far subject.

6 AUTO/MANUAL button and AUTO indicator

Press this button to select focus mode, AUTO or MANUAL.

When AUTO is selected, the AUTO indicator lights and the FOCUS control and the ONE PUSH AF button are disabled.

When MANUAL is selected, the FOCUS control and the ONE PUSH AF button are enabled (with the FOCUS indicator lit).

- 7 ONE PUSH AF button**
Press this button to perform the one-push auto focus function.
- 8 RESET button**
Hold down this button and press one of the POSITION buttons, and the memory of the camera corresponding to the pressed POSITION button is cleared to the factory-preset conditions.
When multiple cameras are connected, hold down this button and press the POWER button to set the camera addresses automatically.
- 9 PRESET button**
Hold down this button and press one of the POSITION buttons, and the current camera settings are stored in the memory of the camera corresponding to the pressed POSITION button.
- 10 PANEL LIGHT button**
Press this button to illuminate all the POSITION buttons and CAMERA buttons. Press the button again to turn off the illumination.
- 11 BACK LIGHT button**
When FULL AUTO, SHUTTER Pri, IRIS Pri or GAIN Pri is selected with MODE of the EXPOSURE menu, press this button to enable the backlight compensation function of the camera. Press it again to disable the function.
Hold down the SHIFT button and press this button to enable the spotlight compensation function of the camera. This function adjusts the exposure to a darker level if a portion of the shooting object is illuminated.
To disable the spotlight compensation, hold down the SHIFT button and press this button again.
- 12 PAN-TILT RESET button**
Press this button to reset the pan/tilt position of the camera to the initial conditions.
- 13 ONE PUSH AWB button**
When ONE PUSH is selected with the WHITE BALANCE menu of the camera, press this button to perform the one-push white balance adjustment.
- 14 MENU button**

Press this button for about one second to display or turn off the menu of the camera, or return to the main menu.

15 Joystick

When the menu of the camera is not displayed

The joystick is used for pan/tilt and zoom operations.

When you incline the joystick right and left, the camera pans. When you incline it forward or backward, the camera tilts. The pan/tilt speed changes according to the angle of the inclination. When you release the joystick, the camera movement stops.

When you turn the dial on the upper part of the joystick clockwise, the subject becomes larger (zoom in). When you turn it counterclockwise, the subject becomes smaller (zoom out).

When you press the button on the top of the joystick for one or two seconds regardless of the PAN TILT ZOOM menu setting, the pan/tilt/zoom are reset and the camera returns to the front.

When the menu of the camera is displayed

The joystick is used for menu operations.

Inclining the joystick right, left, forward and backward has the same function as pressing the arrow buttons of the supplied Remote Commander. Pressing the button on the top of the joystick has the same function as pressing the HOME button on the Remote Commander.

16 SHIFT button and indicators

Hold down this button and press one of the POSITION buttons. The lower indicator lights and you can use the POSITION buttons for positions 9 to 16. If you release the SHIFT button, the upper indicator lights and the POSITION buttons can be used for positions 1 to 8.

17 L/R DIRECTION button

Hold down this button and press POSITION button 2 (REV) to reverse the pan direction to the direction in which you incline the joystick. To reset the direction, hold down this button and press POSITION button 1 (STD).

18 POWER button

Press this button to light the CAMERA button(s) corresponding to the status of the connected camera(s).

Blue: The power of the camera is on.

Yellow green: The camera is in standby mode.

Off: No camera is connected.

Hold down this button and press CAMERA button 1 to 7 to turn on/off the power of the camera corresponding to the pressed button.

19 CAMERA buttons

Press one of the buttons to select the camera from among those connected. The selected CAMERA button lights in blue.

20 POSITION buttons

You can store the various camera settings such as the pan, tilt and zoom positions to the memory of the camera corresponding to each POSITION button, and load the settings in the memory.

Rear/Bottom

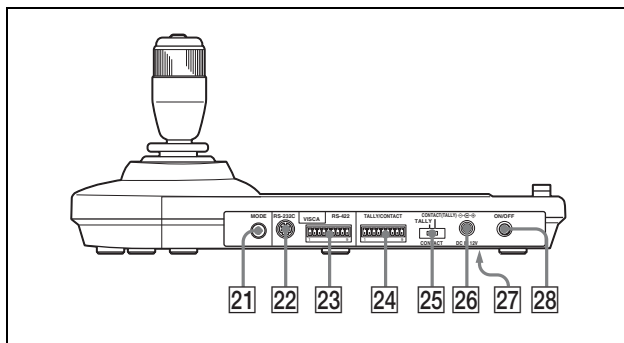

21 MODE selector

Select the position corresponding to the VISCA-controllable camera to be connected.

| Switch position | Camera mode |
|-----------------|----------------------------------|
| 0 | Automatically selected (default) |
| 1 | BRC-300/300P |
| 2 | EVI-D70/D70P |
| 3 | EVI-D100/D100P |
| 4 | EVI-D30/D30P |
| 5 | SNC-RZ30N |
| 6 | BRC-H700 |

Note

Set the selector to position 6 when all the connected cameras are BRC-H700s. For other connections, set the selector to position 0.

22 VISCA RS-232C connector

Connect to the VISCA RS-232C IN connector of the camera or the BRU-H700 HD Optical Multiplex Unit.

23 VISCA RS-422 connector

Connect to the VISCA RS-422 connector of the camera or the BRU-H700 HD Optical Multiplex Unit.

An RS-422 connector plug is attached at the factory.

24 TALLY/CONTACT connector

This connector is used for the tally lamp input or the contact output.

Select the function of the connector using the TALLY/CONTACT selector.

An RS-422 connector plug is attached at the factory.

25 TALLY/CONTACT selector

Select the function of the TALLY/CONTACT connector.

TALLY: The tally lamp of the camera selected with the connected switcher lights.

CONTACT: The contact output corresponding to the camera address selected with the Remote Control Unit is short-circuited against the connected switcher.

CONTACT (TALLY): The contact output corresponding to the camera address selected with the Remote Control Unit is short-circuited against the connected switcher and the tally lamp of the camera selected with the connected switcher lights.

Note

Change the setting of the selector before you turn on the power of the Remote Control Unit. Otherwise, the setting is not effective.

26 DC IN 12V connector

Connect the supplied AC power adaptor.

27 DIP switches (bottom)

Switch 1 (RS-232C/RS-422 selector)

Set to ON for RS-422, or OFF for RS-232C.

Switch 2 (Communication baud rate selector)

Set to ON for 38400bps, or OFF for 9600bps.

Note

Set the DIP switches before you turn on the power of the Remote Control Unit. Otherwise, the setting is not effective.

28 ON/OFF switch

Press this switch to turn on/off the Remote Control Unit.

BRU-H700 HD Optical Multiplex Unit (not supplied)

Front

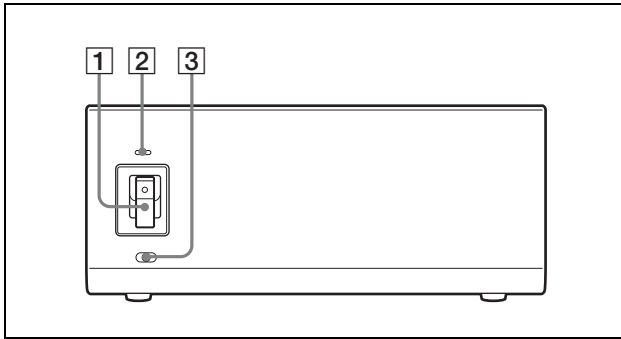

- 1 Power switch**
Turns on/off the power of the HD Optical Multiplex Unit.
Turn on the power of the BRC-H700 camera before you turn on the HD Optical Multiplex Unit.
- 2 Power indicator**
Lit in green: The HD Optical Multiplex Unit is in normal operation.
Lit in red: The power of the camera is turned off. Turn it on.
Flashing in red: Abnormal operation of the HD Optical Multiplex Unit. Display the component video signal on the monitor and check the error message. Check also the connection.

For the error message, see “List of Messages” on page 67.
- 3 DATA MIX switch**
Set the switch to ON to overlap the menu with the video signal output from the installed interface board. Set it to OFF not to overlap the menu.

Rear

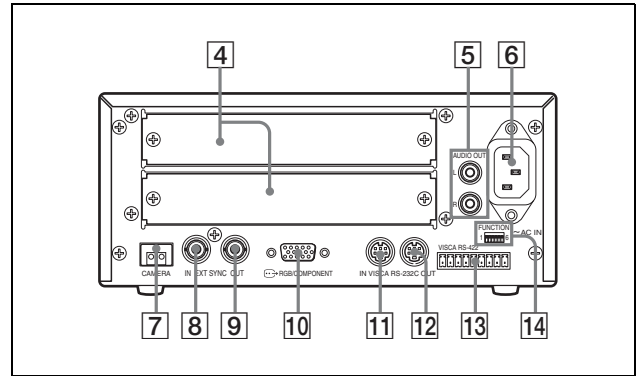

- 4 Card slot**
Insert an optional interface board, HFBK-SD1, HFBK-HD1, HFBK-XG1 or HFBK-TS1.
The slot cover is attached to the unit at the factory.
- 5 AUDIO OUT L/R jacks**
Loop through output of the audio line signal input from the AUDIO IN jacks on the BRBK-H700 HD Optical Multiplex Card inserted into the camera via the Optical Fiber Cable.
- 6 ~AC IN connector**
Connect the supplied AC power cord.
- 7 CAMERA connector**
Connect to the optical connector of the BRBK-H700 HD Optical Multiplex Card installed in the BRC-H700 camera using the CCFC-M100HG Optical Fiber Cable.
A dustproof cap is attached at the factory.
- 8 EXT SYNC IN connector**
Accepts external video sync signals.
- 9 EXT SYNC OUT connector**
Supplies external video sync signals input from the EXT SYNC IN connector.
- 10 RGB/COMPONENT connector**
Supplies the images from the camera as YPbPr or RGB signal.
- 11 VISCA RS-232C IN connector**
Connect to the RM-BR300 Remote Control Unit (not supplied). When you connect multiple cameras, connect it to the VISCA RS-232C OUT connector of the previous camera in the daisy chain connection.
- 12 VISCA RS-232C OUT connector**
When you connect multiple cameras, connect it to the VISCA RS-232C IN connector of the next camera in the daisy chain connection.

- 13 VISCA RS-422 connector**
Connect to the VISCA RS-422 connector of the camera or another BRU-H700 HD Optical Multiplex Unit.

For the connection to the VISCA RS-422 connector, see “Using the VISCA RS-422 Connector Plug” on back cover.

- 14 VISCA FUNCTION switches**
These switches are used for the VISCA communication settings.

Switch 1 (RS-232C/RS-422 selector)
Set to ON for RS-422, or OFF for RS-232C.

Switch 2 (Communication baud rate selector)
Set to ON for 38400bps, or OFF for 9600bps.

Switches 3 to 5 (Camera address selectors)
Set the address of the camera.
Normally set to “0”. With this setting, addresses are assigned to the cameras automatically in the connected order by pressing the POWER button while holding down the RESET button on the RM-BR300 Remote Control Unit.
You can assign the camera address “1” to “7” manually by setting these selectors as follows:

| Camera address | 0 | 1 | 2 | 3 | 4 | 5 | 6 | 7 |
|----------------|-----|-----|-----|-----|-----|-----|-----|----|
| Switch 3 | OFF | ON | OFF | ON | OFF | ON | OFF | ON |
| Switch 4 | OFF | OFF | ON | ON | OFF | OFF | ON | ON |
| Switch 5 | OFF | OFF | OFF | OFF | ON | ON | ON | ON |

Switch 6 (59.94i/50i signal format selector)
Set to ON for output of 50i signal format, or OFF for output of 59.94i signal format.

Note

Set the switches before you turn on the power of the unit.

HFBK-SD1 SD Interface Board (not supplied)

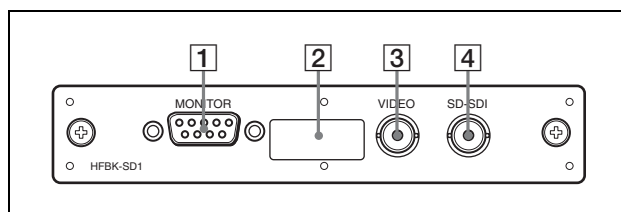

- 1 MONITOR connector (D-sub 9-pin)**
Supplies various analog signals such as composite video, S video, component video and RGB signals. The output signal can be selected in the DOWN CONVERTER menu of the camera.
- 2 DIP switches (inside the cap)**
When this interface board is inserted into the BRC-H700 camera or the BRU-H700 HD Optical Multiplex Unit, the DIP switches cannot be used.
- 3 VIDEO connector (BNC type)**
Supplies analog composite signals. The aspect ratio can be selected in the DOWN CONVERTER menu of the camera.
- 4 SD-SDI connector (BNC type)**
Supplies down-converted SD-SDI signals that conform to SMPTE259M (for 59.94i signal format) or ITU-R BT.656 (for 50i signal format) serial digital interface standards. The aspect ratio can be selected with the DOWN CONVERTER menu of the camera.

HFBK-HD1 HD Interface Board (not supplied)

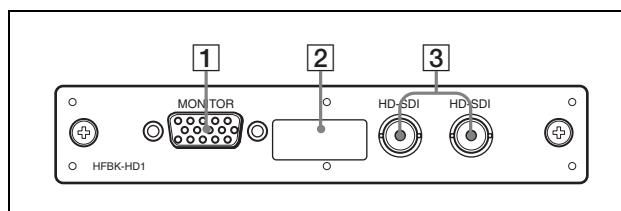

- 1 MONITOR connector (D-sub 15-pin)**
Supplies analog video signals (component or RGB). The output signal can be selected in the HD-SDI menu of the camera.
- 2 DIP switches (inside the cap)**
When this interface board is inserted into the BRC-H700 camera or the BRU-H700 HD Optical Multiplex Unit, the DIP switches cannot be used.

- 3 HD-SDI connector (BNC type)**
Supplies HD-SDI signals that conform to the SMPTE292M serial digital interface standards. The two connectors output the same signal.

HFBK-XG1 XGA Interface Board (not supplied)

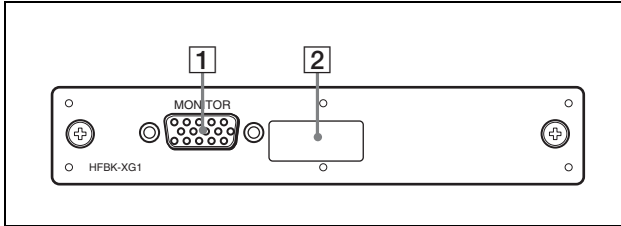

- 1 MONITOR connector (D-sub 15-pin)**
Supplies video signals after conversion to VGA, XGA or WXGA. The standards of output signal and aspect ratio can be specified in the PC-OUTPUT menu.
- 2 DIP switches (inside the cap)**
When this interface board is inserted into the BRC-H700 camera or the BRU-H700 HD Optical Multiplex Unit, the DIP switches cannot be used.

HFBK-TS1 HDV Interface Board (not supplied)

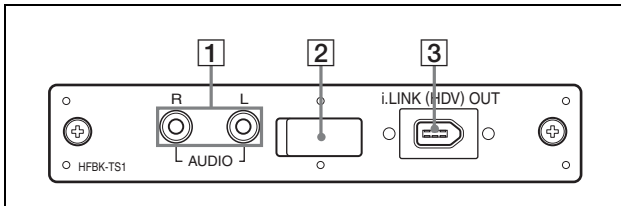

- 1 AUDIO L/R jacks (phono type)**
Input audio signals (stereo).
The input audio signals are converted into signals that comply with HDV standards.
- 2 DIP switches (inside the cap)**
When this interface board is inserted into the BRC-H700 camera or the BRU-H700 HD Optical Multiplex Unit, the DIP switches cannot be used.
- 3 i.LINK (HDV) OUT connector (i.Link 6-pin)**
Supplies video and audio signals after they are converted to comply with HDV standards.

Note

The audio input on this board accepts audio line signals only. When you input audio signals from a microphone, etc., it should be connected with a microphone amplifier so that audio signals with an appropriate audio level can be input.

BRBK-H700 HD Optical Multiplex Card (not supplied)

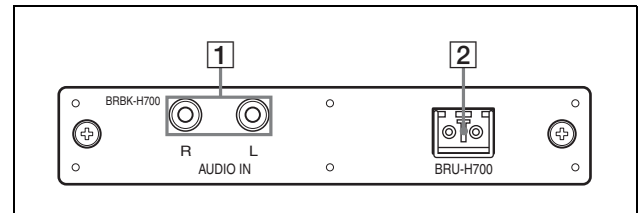

- 1 AUDIO IN L/R jacks (phono type)**
Input an audio signal (stereo) that is output from the AUDIO OUT jacks on the BRBK-H700 HD Optical Multiplex Unit via the Optical Fiber Cable.

Note

The audio input on this board accepts audio line signals only. When you input audio signals from a microphone, etc., it should be connected with a microphone amplifier so that audio signals with an appropriate audio level can be input.

- 2 Optical connector**
Performs the optical digital multiplex transmission of video, audio, external sync and control signals.
A dustproof cap is attached at the factory.

About On-Screen Menus

You can change various settings, such as shooting conditions and system setup of the camera, while observing menus displayed on a connected monitor. This section explains how to read the on-screen menus before starting menu operations.

For the overall menu configurations, see page 70.

Note

You cannot perform pan/tilt and zoom operations while the menu is displayed.

Main Menu

To display the main menu, press the DATA SCREEN button on the supplied Remote Commander or the MENU button on the RM-BR300 Remote Control Unit.

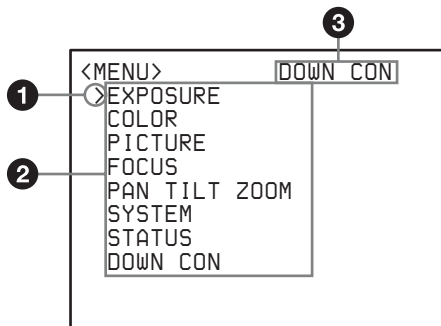

- 1 Cursor**
Selects a setting menu.
Move the cursor up or down by pressing the \uparrow or \downarrow button on the Remote Commander or by inclining the joystick of the RM-BR300 Remote Control Unit forward or backward.
- 2 Menu items**
To display a setting menu, select one using the \uparrow or \downarrow button on the Remote Commander or the joystick of the RM-BR300 Remote Control Unit, and press the HOME button on the Remote Commander or the top button of the joystick on the RM-BR300.
- 3 Option board indicator**
Displays the name of the interface board inserted into the card slot of the camera.
(The illustration above shows an example when the HFBK-SD1 SD Interface Board is inserted.)

Setting Menu

The setting menu selected on the main menu is displayed.

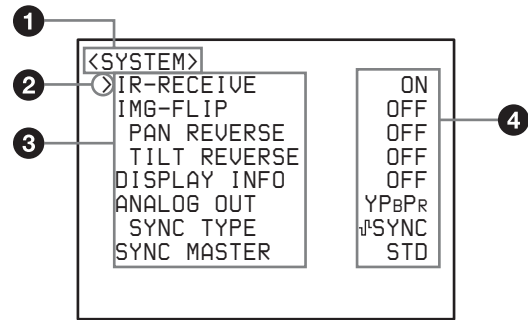

- 1 Setting menu**
The name of the setting menu currently selected is displayed here.
- 2 Cursor**
Selects a setting item.
Move the cursor up or down by pressing the \uparrow or \downarrow button on the Remote Commander or inclining the joystick of the RM-BR300 Remote Control Unit forward or backward.
- 3 Setting items**
The setting items for this setting menu are displayed.
To change a set value, select the setting item using the \uparrow or \downarrow button on the Remote Commander or the joystick of the RM-BR300 Remote Control Unit, and press the \leftarrow or \rightarrow button on the Remote Commander or incline the joystick on the RM-BR300 right or left.
- 4 Set value**
The currently set values are displayed.
To change a set value, use the \leftarrow or \rightarrow button on the Remote Commander or the joystick of the RM-BR300 Remote Control Unit.

For the default value of each setting item, see “Menu Configuration” on page 70.

Operation Through Menus

This section explains how to operate the menu using the supplied Remote Commander, or using the RM-BR300 Remote Control Unit (not supplied).

For details on each menu, see pages 30 through 38.

Menu Operation Using the Supplied Remote Commander

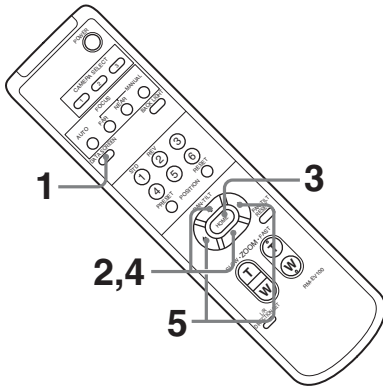

- 1 Press the DATA SCREEN button.
The main menu appears.

```

<MENU>          DOWN CON
>EXPOSURE
COLOR
PICTURE
FOCUS
PAN TILT ZOOM
SYSTEM
STATUS
DOWN CON
    
```

- 2 Move the cursor to the menu item to be set by pressing the **↑** or **↓** button.

- 3 Press the HOME button.
The selected menu appears.

```

<SYSTEM>
>IR-RECEIVE      ON
IMG-FLIP         OFF
PAN REVERSE      OFF
TILT REVERSE     OFF
DISPLAY INFO     OFF
ANALOG OUT       YPBPr
SYNC TYPE        I-SYNC
SYNC MASTER      STD
    
```

- 4 Move the cursor to the setting item to be changed by pressing the **↑** or **↓** button.
- 5 Change the value by pressing the **←** or **→** button.

```

<SYSTEM>
IR-RECEIVE      ON
IMG-FLIP         OFF
PAN REVERSE      OFF
TILT REVERSE     OFF
>DISPLAY INFO    ON
ANALOG OUT       YPBPr
SYNC TYPE        I-SYNC
SYNC MASTER      STD
    
```

Note

When you are operating the menu using the supplied Remote Commander, you cannot set IR-RECEIVE in the SYSTEM menu to OFF. To set IR-RECEIVE to OFF, use the RM-BR300 Remote Control Unit or the VISCA command.

To return to the main menu

Press the DATA SCREEN button.

To return to the normal display

Press the DATA SCREEN button when the main menu is displayed.

Menu Operation Using the RM-BR300 Remote Control Unit

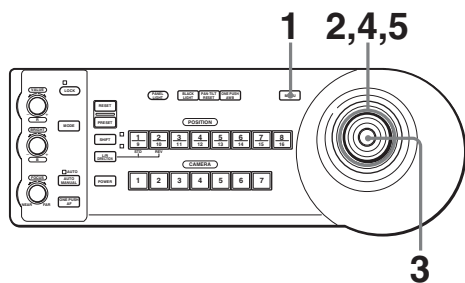

- 1 Press the MAIN button.
The main menu appears.

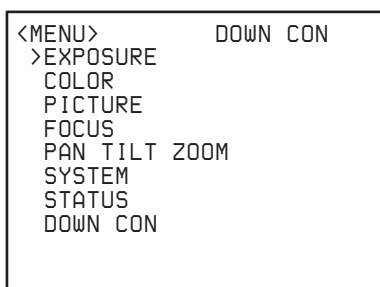

- 2 Move the cursor to the menu item to be set by inclining the joystick forward or backward.
- 3 Press the button on the top of the joystick.
The selected menu appears.

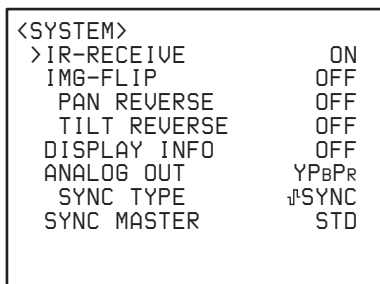

- 4 Move the cursor to the setting item to be changed by inclining the joystick forward or backward.

- 5 Change the value by inclining the joystick right or left.

```

<SYSTEM>
IR-RECEIVE      ON
IMG-FLIP       OFF
PAN REVERSE    OFF
TILT REVERSE   OFF
>DISPLAY INFO   ON
ANALOG OUT     YPbPr
SYNC TYPE      ⌄SYNC
SYNC MASTER    STD
  
```

To return to the main menu

Press the MENU button.

To return to the normal display

Press the MENU button when the main menu is displayed.

EXPOSURE Menu

The EXPOSURE menu is used to set the items regarding the exposure.

| | |
|------------|-----------|
| <EXPOSURE> | ND: OFF |
| >MODE | FULL AUTO |
| AE SPEED | MID |
| AGC LIMIT | 18dB |
| IRIS LIMIT | OFF |
| EX-COMP | OFF |
| BACK LIGHT | OFF |
| SPOT LIGHT | OFF |

ND (ND filter)

Indicates the setting of the built-in ND filter in the camera. OFF, 1 or 2 will be displayed. The ND setting is selectable with the ND select switch on the camera, and cannot be selected in the menu. For details on the ND filter setting, see “Using the ND Filter” on page 31.

MODE (exposure mode)

FULL AUTO: The exposure is adjusted automatically using the sensitivity, electronic shutter speed and iris.

MANUAL: The sensitivity (GAIN), electronic shutter speed (SPEED) and iris (IRIS) are adjusted manually.

SHUTTER Pri: Shutter Priority mode. The exposure is adjusted automatically using the sensitivity and iris. Adjust the electronic shutter speed (SPEED) manually.

IRIS Pri: Iris Priority mode. The exposure is adjusted automatically using the sensitivity and electronic shutter speed. Adjust the iris (IRIS) manually.

GAIN Pri: Sensitivity Priority mode. The exposure is adjusted automatically using the iris and electronic shutter speed. Adjust the sensitivity (GAIN) manually.

When you select MODE, some of the following setting items that are required for the selected mode appear.

AE SPEED: Select the exposure adjustment speed at which an optimum exposure value is obtained automatically. You can select LOW (slow speed), MID (normal speed) or HIGH (fast speed). Select when the brightness of the object is changed momentarily.

AGC LIMIT: Select the maximum gain level to be adjusted in automatic exposure mode. Select a value from among 0, 6, 12 dB and 18 dB. If you set the item to OFF, the gain is adjusted without limitation.

IRIS LIMIT: Select the maximum iris to be adjusted in automatic exposure mode. Select a value from among F3.4, F4.0, F6.8 and F11.

GAIN: Select the gain from among the following: 0, 3, 6, 9, 12, 15, 18dB, HYPER

SPEED: Select the electric shutter speed from among the following:

For the 59.94i signal format

1/60, 1/90, 1/100, 1/125, 1/180, 1/250, 1/350, 1/500, 1/725, 1/1000, 1/1500, 1/2000, 1/3000, 1/4000, 1/6000, 1/10000

For the 50i signal format

1/50, 1/75, 1/100, 1/120, 1/150, 1/215, 1/300, 1/425, 1/600, 1/1000, 1/1250, 1/1750, 1/2500, 1/3500, 1/6000, 1/10000

IRIS: Select the iris from among the following:

CLOSE, F11, F10, F9.6, F8.7, F8.0, F7.3, F6.8, F6.2, F5.6, F5.2, F4.8, F4.4, F4.0, F3.7, F3.4, F3.1, F2.8, F2.6, F2.4, F2.2, F2.0, F1.8, F1.7, F1.6

EX-COMP (exposure compensation)

When MODE is set this item to FULL AUTO, SHUTTER Pri, IRIS Pri or GAIN Pri, set this item to ON to enable exposure compensation.

When you set EX-COMP to ON, LEVEL appears and you can select the exposure compensation level from among the following:

-7, -6, -5, -4, -3, -2, -1, 0, +1, +2, +3, +4, +5, +6, +7
If you set the level to 0, exposure compensation will be disabled. Level +7 is the brightest and -7 is the darkest compensation values.

When EX-COMP is set to OFF, exposure compensation does not function.

BACK LIGHT

Setting the item to ON enables the BACK LIGHT function. Setting it to OFF disables the function.

SPOT LIGHT

The SPOT LIGHT function allows exposure adjustment at darker levels if a portion of the object to be shot is illuminated.

Setting the item to ON enables the SPOT LIGHT function. Setting it to OFF disables the function.

Note

You cannot use both the BACK LIGHT and SPOT LIGHT functions at the same time.

Using the ND Filter

You can use the built-in ND filter of the camera according to the brightness of the object to be shot. Select the ND filter setting on the ND filter select switch at the bottom of the camera block.

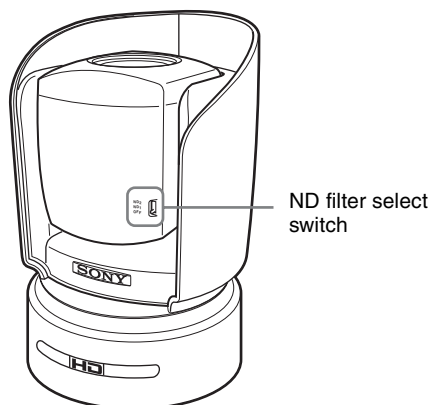

| Switch position | Function |
|-----------------|--|
| OFF | Disables the ND filter |
| ND1 | Uses the ND filter to reduce the output luminance level to approximately one sixth |
| ND2 | Uses the ND filter to reduce the output luminance level to approximately 1/32 |

Note

You can check the current setting of the ND filter select switch in the EXPOSURE menu, but you cannot change the setting in the menu.

COLOR Menu

The COLOR menu is used to adjust the white balance and the color.

| | |
|----------------|------|
| <COLOR> | |
| >WHITE BALANCE | AUTO |
| WB SENS | MID |
| WB SHIFT | 0 |
| COLOR | |
| GAIN | 0 |
| HUE | 0 |

WHITE BALANCE (white balance mode)

Select the white balance mode from among the following:

AUTO, INDOOR, OUTDOOR, ONE PUSH, MANUAL

When you select WHITE BALANCE, some of the following setting items that are required for the selected mode appear.

WB SENS: When an object is shot under a reddish light source such as an incandescent lamp, candle, or under a bluish light source such as in the shade, you can adjust the red or blue tint. Set WB SENS to HIGH to reduce the red or blue tint, and set it to LOW to increase a red or blue tint. This function is not effective in the sun.

WB SHIFT: You can shift the white balance focusing point to your favorite red or blue tint in automatic white balance mode. The adjustable range is from -7 to +7. It shifts toward a red tint in the + direction, and a blue tint in the - direction.

R. GAIN, B. GAIN: When you select MANUAL, R. GAIN (red gain) and B. GAIN (blue gain) appear. Adjustable range of each item is from -128 to +127.

When ONE PUSH is selected

Zoom in on a white subject in the center of the screen and press the HOME button of the supplied Remote Commander. The one-push white balance adjustment is activated.

When you are using the RM-BR300 remote control unit (not supplied), pressing the button on the top of the joystick or the ONE PUSH AWB button activates the one-push white balance adjustment.

COLOR

GAIN: Adjusts the color intensity of the picture. The adjustable range is from -7 to +7. The color

intensity increases in the + direction, and decreases in the – direction.

HUE: Adjusts the color tint of an image. The adjustable range is from –7 to +7. The red tint increases in the + direction, and the green tint increases in the – direction.

PICTURE Menu

The PICTURE menu is used to adjust the picture quality.

| | | |
|-----------------|--|----------|
| <PICTURE> | | |
| >DETAIL | | 7 |
| SKINTONE DETAIL | | OFF |
| GAMMA | | NORMAL |
| FLICKER CANCEL | | OFF |
| STEADY SHOT | | STANDARD |
| B&W | | OFF |
| COLOR BAR | | OFF |

DETAIL

Select the image enhancer level.

The adjustable level is in the range of 0 to 15. The larger the setting level, the sharper the image outline. You can obtain the softest image outline by selecting level 0.

SKINTONE DETAIL

Makes wrinkles inconspicuous by suppressing the image enhancer in the skin-colored area of an object.

Type 1: The range of color recognized as skin color is narrow.

Type 2: The range of color recognized as skin color is between those of Type 1 and 3.

Type 3: The range of color recognized as skin color is extensive.

OFF: The SKINTONE DETAIL function is disabled.

GAMMA

Select the gamma curb of the camera.

NORMAL: The object is shot using normal gamma curb.

CINEMA: The object is shot using a gamma curb to reproduce a film-like picture with a natural tone.

FLICKER CANCEL

When this item is set to ON, picture blurs (flicker) can be reduced even when shooting under a 50Hz fluorescent light. Set it to OFF to disable this feature.

Note

The FLICKER CANCEL feature may have no effect depending on the type of light source.

STEADY SHOT

You can select the effects of picture blur compensation.

OFF: Disables the picture blur compensation depending on shooting conditions.

SOFT: Sets picture blur compensation with the exception of natural blur.

STANDARD: Sets normal picture blur compensation.

HARD: Sets maximum picture blur compensation.

Note

This feature does not function while the camera is panning or tilting.

B&W (black and white mode)

When this item is set to ON, an image is shot in black and white.

COLOR BAR

When this item is set to ON, the built-in color bar of the camera is displayed on the monitor screen.

FOCUS Menu

The FOCUS menu is used to select the focus mode.

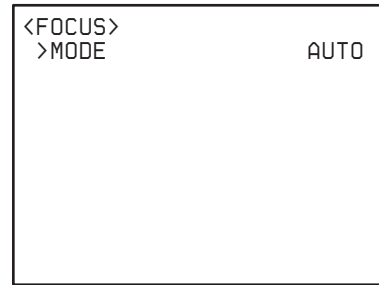

MODE (focus mode)

Select the focus adjustment mode.

AUTO: The focus is adjusted automatically.

MANUAL: Adjust the focus manually. Use the FAR/NEAR buttons on the supplied Remote Commander to adjust the focus.

PAN TILT ZOOM Menu

The PAN TILT ZOOM menu is used to select the pan/tilt/zoom mode.

| | |
|-----------------|-------|
| <PAN TILT ZOOM> | |
| PAN-TILT LIMIT | |
| > PAN | OFF |
| LEFT | END |
| RIGHT | END |
| TILT | OFF |
| DOWN | END |
| UP | END |
| RAMP CURVE | MODE1 |
| D-ZOOM | x4.0 |

PAN-TILT LIMIT

When you set PAN to ON, you can select the limit of pan operation with the LEFT and RIGHT setting items. When you set TILT to ON, you can select the limit of tilt operation with the UP and DOWN setting items. You can select the following values:

PAN LEFT: END, 169° to -169° , selectable with an interval of 1°

PAN RIGHT: END, -169° to 169° , selectable with an interval of 1°

TILT DOWN: END, -29° to 89° , selectable with an interval of 1°

TILT UP: END, 89° to -29° , selectable with an interval of 1°

Setting range of PAN LEFT/PAN RIGHT

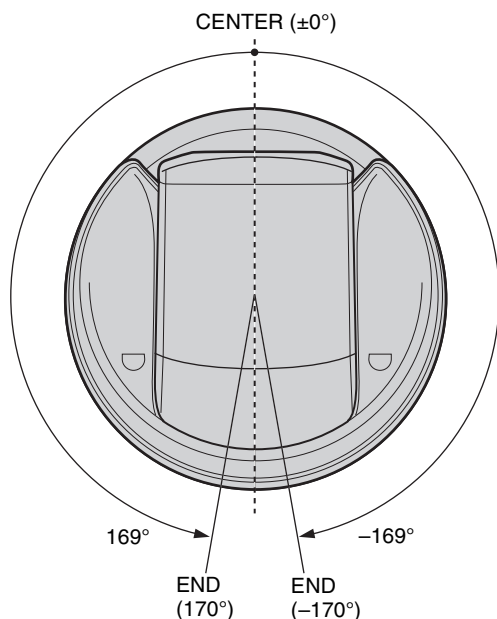

Setting range of TILT DOWN/TILT UP

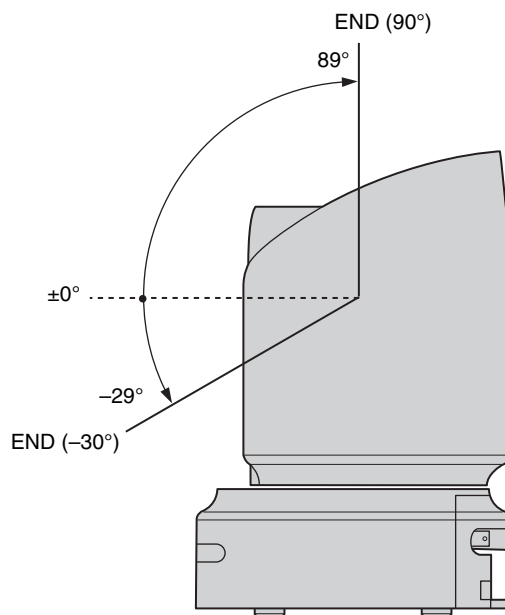

Note

The PAN-TILT LIMIT setting is reset to the factory setting when you change IM-FLIP of the SYSTEM menu.

RAMP CURVE

Select the panning and tilting speed acceleration or reduction mode when the preset panning and tilting operation is recalled.

MODE1: Panning/tilting speed accelerates or reduces most sharply.

MODE2: Panning/tilting speed accelerates or reduces moderately.

MODE3: Panning/tilting speed accelerates or reduces most gently.

D-ZOOM (digital zoom)

When you select digital zoom magnification (4×, 2× or 1.5×), the selected electronic zoom operates after the optical zoom (12×). You can zoom up to 48× at maximum.

When this item is set to OFF, the digital zoom function is disabled.

Note

Regardless of the D-ZOOM setting, images shot by the camera are accumulated for the vertical synchronization period and output from the RGB/COMPONENT connector of the camera and the connector on the optional interface board inserted into the card slot.

SYSTEM Menu

| | |
|--------------|-------|
| <SYSTEM> | |
| >IR-RECEIVE | ON |
| IMG-FLIP | OFF |
| PAN REVERSE | OFF |
| TILT REVERSE | OFF |
| DISPLAY INFO | OFF |
| ANALOG OUT | YPbPr |
| SYNC TYPE | ┐SYNC |
| SYNC MASTER | STD |

IR-RECEIVE (infrared signal reception)

When it is set to OFF, the camera does not receive the signal from the supplied Remote Commander.

Be sure to keep it ON when you use the supplied Remote Commander.

Note

You cannot set IR-RECEIVE to OFF when you operate the menu using the supplied Remote Commander. To set it to OFF, use the RM-BR300 Remote Control Unit (not supplied) or the VISCA command.

IMG-FLIP (image flip)

Set IMG-FLIP to ON to rotate the camera image supplied from the RGB/COMPONENT connector upside down and to reverse the direction of the camera movement by pan/tilt operation.

Set PAN REVERSE to ON to reverse the horizontal movement of the camera image.

Set TILT REVERSE to ON to reverse the vertical movement of the camera image.

When you set IMG-FLIP to ON, "Please restart system!" appears. Turn off the power of the camera and turn it on again.

Note

- Regardless of the IMG-FLIP ON/OFF setting, images shot by the camera are accumulated for the vertical synchronization period and output from the RGB/COMPONENT connector of the camera and the connector on the optional interface board inserted into the card slot.
- When you set IMG-FLIP to ON, then turn off the camera and turn it on again, PAN REVERSE and TILT REVERSE will be set to ON. When you set IMG-FLIP to OFF, then turn the power off and on again, PAN REVERSE and TILT REVERSE will be set to OFF.

DISPLAY INFO (information display)

When the camera settings are stored in POSITION 1 to 16 using the supplied Remote Commander or the RM-

BR300 Remote Control Unit, the message "PRESET No. xx" automatically appears for 2 seconds on the monitor screen. If you want to display the message each time the camera is operated, set DISPLAY INFO to ON. Set it to OFF to cancel the display.

Notes

- If the built-in cooling fan of the camera has accidentally stopped, a certain message appears in the image signal of the interface board inserted in the RGB/COMPONENT terminal and the card slot in this camera. The message is displayed when DISPLAY INFO is set to ON, and is not displayed when it is set to OFF. The display setting of the message is active in the transmission from the optional BRU-H700. Whether DISPLAY INFO is ON or OFF, the tally lamp on the top of the camera flashes at approximately 0.5-second intervals.
- If the DATA MIX switches on the rear of the camera and in the optional BRU-H700 are set to OFF, the caution about the fan is not displayed in the interface board output inserted in the card slot in the camera or BRU-H700. In this case, the menu is not displayed, either.

ANALOG OUT

Select the signal output from the RGB/COMPONENT connector on the camera. Select YPbPr for component signal output, or RGB for RGB signal output.

When RGB is selected with ANALOG OUT, ADD SYNC appears. If you set ADD SYNC to RGB, a sync signal is added to each R, G and B signal. If you set it to OFF, no sync signal is added.

SYNC TYPE appears when either YPbPr or RGB is selected with ANALOG OUT, and you can select the type of sync signal, ┐SYNC for tri-level sync or VD for bi-level sync.

SYNC MASTER

When you connect a sync signal generator, you can select an output video signal that is synchronized with the external video sync signal input to the EXT SYNC IN connector on the camera from the generator.

STD: The output video signal from the RGB/COMPONENT connector on the camera is synchronized with the external video sync signal.

HD1: The output signal from the HFBK-HD1 HD Interface Board inserted into the camera is synchronized with the external sync signal.

SD1: The output signal from the HFBK-SD1 SD Interface Board inserted into the camera is synchronized with the external sync signal.

Note

This menu item is available when the HFBK-HD1 or HFBK-SD1 Interface Board is inserted into the BRU-H700 HD Optical Multiplex Unit.

STATUS Menu

The STATUS menu is used to display the settings selected with the menus.

```
<STATUS>                PAGE1
EXPOSURE                FULL AUTO
AE SPEED                MID
AGC LIMIT                18dB
IRIS LIMIT                OFF
EX-COMP                OFF 0
BACK LIGHT                OFF
SPOT LIGHT                OFF
FOCUS                    AUTO
```

The STATUS menu consists of PAGE1 to PAGE5. This menu only displays the current menu settings, and you cannot change them with the menu.

- PAGE1:** Shows the settings selected with the EXPOSURE and FOCUS menus.
- PAGE2:** Shows the settings selected with the COLOR menu.
- PAGE3:** Shows the settings selected with the PAN TILT ZOOM menu.
- PAGE4:** Shows the STEADY SHOT, IR-RECEIVE, IMG-FLIP, REVERSE PAN, DISPLAY INFO, COLOR BAR and FLICKER CANCEL settings selected with the SYSTEM menu.
- PAGE5:** Shows the output settings of the output connector on the camera, the firmware versions of the BRC-H700 and BRU-H700 (if connected), etc.

DOWN CONVERTER Menu

The DOWN CONVERTER menu is displayed only when the HFBK-SD1 SD Interface Board is inserted into the card slot of the camera.

```
<DOWN CONVERTER>
>D-SUB OUT1            YPbPr
D-SUB OUT2            VBS
IMG SIZE 16:9[LETTER]
SETUP                OFF
```

D-SUB OUT1

Select the component signal output from the MONITOR connector (D-sub 9-pin) on the HFBK-SD1 SD Interface Board.

YPbPr: Outputs analog component signals.

RGB: Outputs RGB signals.

ADD SYNC

Appears when RGB is selected with D-SUB OUT1 and specifies whether to add a sync signal.

RGB: Outputs each R, G and B signal with a sync signal added.

G: Outputs the G signal with a sync signal added.

OFF: Outputs each signal with no sync signal added.

D-SUB OUT2

Select the output signal from the MONITOR connector on the HFBK-SD1 SD Interface Board.

VBS: Outputs analog composite signals.

Y/C: Outputs S-video signals.

IMG-SIZE (image size)

Select the aspect ratio of the output signal.

16:9[LETTER]: The image is displayed in 16:9 letterbox.

4:3[CROP]: The image is displayed in 4:3 edge crop.

4:3[SQUEEZE]: The image is displayed in 4:3 squeeze.

SETUP

Select whether 7.5IRE setup is added to output signals.

ON: Outputs signals with 7.5IRE setup added.

OFF: Outputs signals with no 7.5IRE setup added.

Note

This menu item does not appear when an HD signal of 50i format is output or when RGB is selected in D-SUB OUT1. The SETUP setting is available when YPbPr is selected in D-SUB OUT1. If your HFBK-SD1 Interface Board is a former version, the SETUP item does not appear even when YPbPr is selected. If you want to use the SETUP setting, please purchase the latest version of the HFBK-SD1, or contact your Sony dealer.

HD-SDI Menu

The HD-SDI menu is displayed only when the HFBK-HD1 HD Interface Board is inserted into the card slot of the camera.

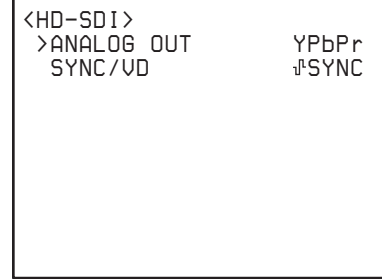

ANALOG OUT

Select the component signal output from the MONITOR connector (D-sub 15-pin) on the HFBK-HD1 HD Interface Board.

YPbPr: Outputs analog component signals.

RGB: Outputs RGB signals.

SYNC VD

Select the signal output from the SYNC output on the MONITOR connector

▣ **SYNC:** Outputs the tri-level sync.

VD: Outputs the bi-level sync.

ADD SYNC

Appears when RGB is selected with ANALOG OUT and specifies whether to add a sync signal.

RGB: Outputs each R, G and B signal with a sync signal added.

OFF: Outputs each signal with no sync signal added.

PC-OUTPUT Menu

The PC-OUTPUT menu is displayed only when the HFBK-XG1 XGA Interface Board is inserted into the card slot of the camera.

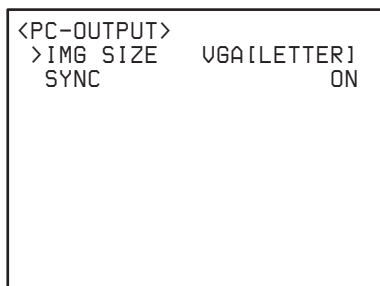

IMG-SIZE (image size)

Select the signal format and aspect ratio of the output signal.

XGA [CROP]: Outputs XGA (4:3 edge crop).

VGA [LETTER]: Outputs VGA (16:9 letterbox).

XGA [LETTER]: Outputs XGA (16:9 letterbox).

VGA [CROP]: Outputs VGA (4:3 edge crop).

WXGA: Outputs WXGA.

SYNC

Specifies whether to add a sync signal to the G signal.

ON: Outputs the G signal with a sync signal added.

OFF: Outputs the G signal with no sync signal added.

VD

Select the VD polarity according to the monitor to be used.

POS: Positive

NEG: Negative

HDV Menu

The HDV menu is displayed only when the HFBK-TS1 HDV Interface Board is inserted into the card slot of the camera.

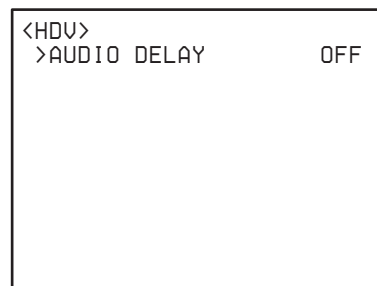

AUDIO DELAY

Compensates for the delay between the video signal output from the camera and audio signal output via the HFBK-TS1 HDV Interface Board. The compensation level can be selected from 1STEP to 10STEP in every STEP.

When it is set to OFF, the compensation feature is disabled.

1STEP stands for one unit of audio frame, which is equal to approximately 24mS.

Operation Using the Supplied Remote Commander

Before operating, check that the camera and peripheral devices are properly installed and connected.

For details, see “Installation” (page 50) and “Connections” (page 57).

Turning on the Power

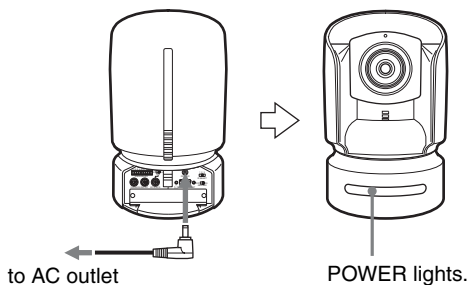

1 Connect the camera to an AC outlet using the supplied AC power adaptor and power cord. The power is turned on and the POWER lamp lights. The camera will automatically pan and tilt and be reset to the position stored in POSITION 1 (Pan/tilt reset action).

2 Turn on the peripheral devices.

To turn on/off the camera using the Remote Commander

As long as the camera is connected to an AC outlet, you can turn the camera on or off with the POWER switch on the Remote Commander.

When you turn the power off using the Remote Commander, the POWER lamp turns off and the STANDBY lamp lights on the camera.

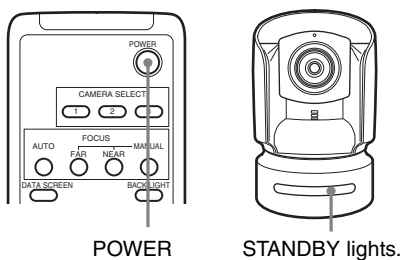

Pan/Tilt and Zoom Operation

Panning and Tilting

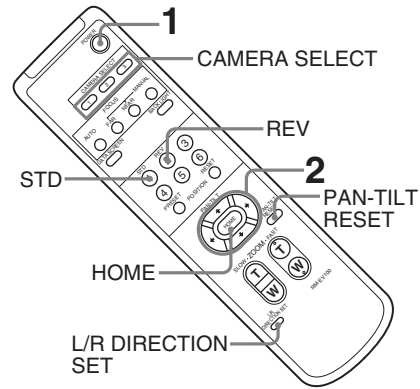

- 1** Press the POWER switch. The camera will turn on and perform the pan/tilt reset action automatically.
- 2** Press the arrow button to pan or tilt the camera. While checking the picture on the screen, press the desired arrow button.
 - To move the camera little by little,** press the button just for a moment.
 - To move the camera in a wide range,** press and hold the button.
 - To move the camera diagonally,** press the ◀ or ▶ button while holding down the ▲ or ▼ button.

To face the camera back to the front







Press the HOME button.

If you accidentally move the camera with your hand

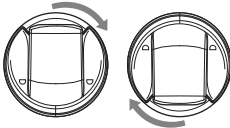
Press the PAN-TILT RESET button to perform the pan/tilt reset action.

If the camera moves in a different direction from that you intended

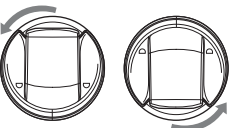
The camera is preset to face toward the right whenever the ▶ button is pressed. You might wish to face the camera toward the opposite direction from that of the button you pressed, for example, when you change the direction of the camera while checking the picture on the screen. In such a case, press the 2 (REV) button while holding down the L/R DIRECTION SET button. To reset the setting, press the 1 (STD) button while holding down the L/R DIRECTION SET button.

| Arrow button | Movement of the camera | Setting |
|---|---|--|
|  |  |  While holding down  Press. |
|  |  |  While holding down  Press. |

Note

The setting above only changes the signal emitted from the Remote Commander, and does not change the setting of the camera itself. Therefore, repeat the setting for each Remote Commander if you are using more than one Remote Commander.

If the STANDBY lamp of the camera flashes

When the camera is moved or turned by hand or by external shock, the microcomputer inside the camera may not be able to memorize the pan/tilt position properly and the camera may stop. To reset the pan/tilt position, press the PAN-TILT RESET button or turn the power of the camera off and turn it on again.

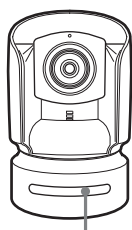

STANDBY flashes.

Zooming

Press either of the ZOOM buttons.

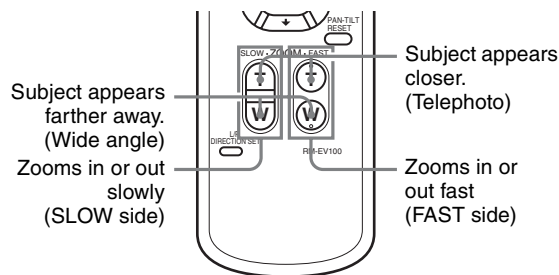

Note

When you perform pan/tilt operation while the camera is in the telephoto mode, the moving speed of the image on the screen may be a little jerky.

Operating Multiple Cameras with the Remote Commander

- 1 Set the IR SELECT switch on the rear of the camera you want to operate to 1, 2 or 3.



- 2 Press the CAMERA SELECT button on the Remote Commander that corresponds to the number set in step 1.

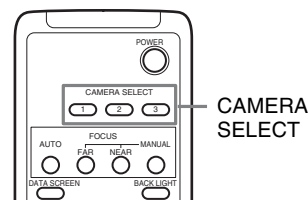

Then, you can operate the camera(s) specified by number. Every time you operate the camera(s) using the Remote Commander, the CAMERA SELECT button pressed in step 2 lights.

Adjusting the Camera

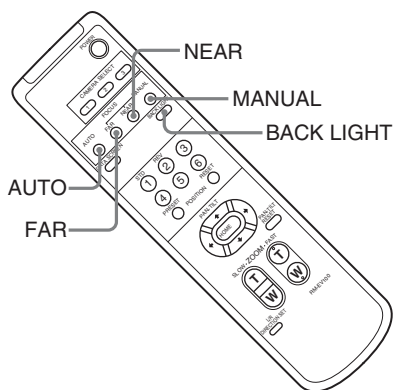

Shooting with Back Lighting

When you shoot a subject with a light source behind it, the subject becomes dark. In such a case, press the BACK LIGHT button.

To cancel the function, press the BACK LIGHT button again.

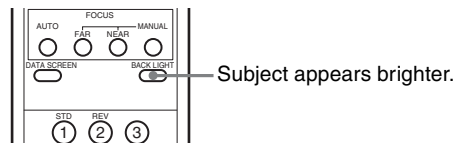

Note

The BACK LIGHT function is not effective if MODE is set to MANUAL in the EXPOSURE menu of the camera.

Focusing on a Subject

To focus the camera on a subject automatically

Press the AUTO button.

The camera focuses on the subject at the center of the screen automatically.

To focus the camera on a subject manually

After pressing the MANUAL button, press either the FAR or the NEAR button to have the camera focus on the subject.

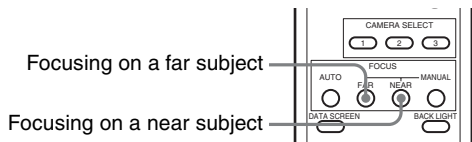

Storing the Camera Settings in Memory

– Presetting Feature

Up to six combinations of settings (six positions) including camera position, zooming, focusing, and backlighting, can be preset.

Note

The camera can store up to sixteen combinations of settings (sixteen positions) in the memory, but the supplied Remote Commander supports preset of six positions only (POSITION 1 to 6). Use the RM-BR300 Remote Control Unit (not supplied) to store the settings in POSITION 7 to 16.

For details of the camera settings to be preset, see “Presetting Items” on page 74.

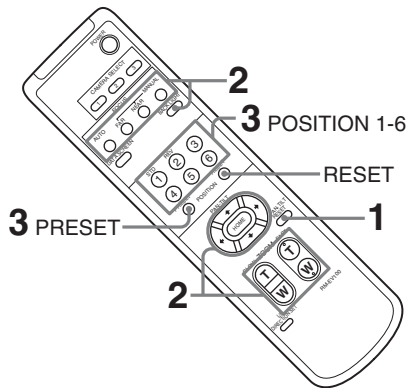

- 1 Press the PAN-TILT RESET button to reset the pan/tilt position.
- 2 Adjust the position, zooming, focusing and backlighting of the camera (pages 39 to 41).
- 3 While holding down the PRESET button, press any of the POSITION buttons, 1 to 6, in which you want to store the settings.

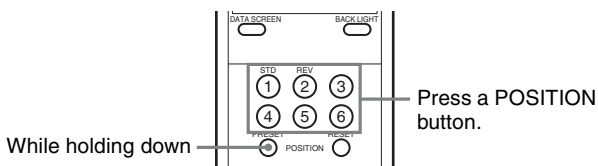

The message “PRESET No.xx” (selected POSITION number) is output from the component or RGB output connector and is displayed for about 2 seconds.

To recall the stored settings

Press any of the POSITION buttons, 1 to 6, in which you have stored the settings.

To cancel the preset memory

While holding down the RESET button, press the POSITION button from which you want to cancel the settings.

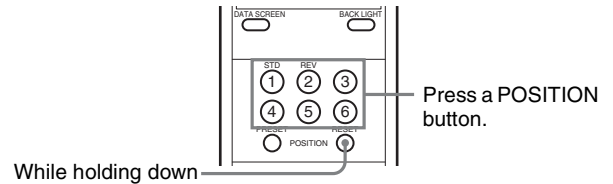

Notes

- When the power is turned on, the camera starts with the settings stored in POSITION 1.
- If you want to retain the previous pan and tilt positions, etc. when the power is turned off and turned on again, store those positions in POSITION 1.
- Storing or canceling the settings in POSITION 1 takes about 2 seconds longer than those of other positions.
- When you are storing or canceling the settings in one POSITION, you cannot call up, store or cancel the settings in another POSITION.

Operation Using the RM-BR300 Remote Control Unit

Before operating, check that the camera, the RM-BR300 Remote Control Unit and peripheral devices are properly installed and connected.

For details, see “Installation” (page 50) and “Connections” (page 57).

Turning on the Power

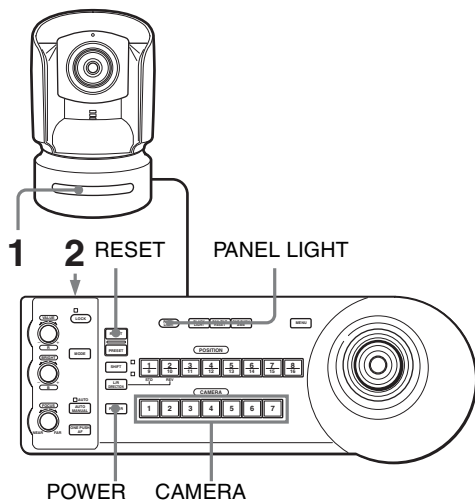

- 1 Connect the camera to an AC outlet using the supplied AC power adaptor and power cord. The power is turned on and the POWER lamp lights. The camera will automatically pan and tilt and be reset to the position stored in POSITION 1 (Pan/tilt reset action).
- 2 Press the ON/OFF switch on the RM-BR300 Remote Control Unit to turn it on. The CAMERA button representing the camera whose power was turned off last lights. (The CAMERA 1 button lights by default.)
- 3 Turn on the peripheral devices.

Note

Be sure to turn on the power of the camera before the power of the Remote Control Unit. Otherwise, the Remote Control Unit cannot recognize the connected camera.

To turn on/off the camera using the RM-BR300 Remote Control Unit

As long as the camera is connected to an AC outlet, you can turn the camera on or off with the POWER button on the Remote Control Unit.

While holding down the POWER button, press the CAMERA button corresponding to the camera whose power you want to turn on/off.

When you turn the power off using the Remote Control Unit, the POWER lamp turns off and the STANDBY lamp lights on the camera.

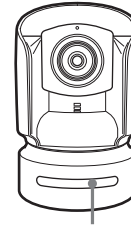

STANDBY lights.

To illuminate the panel of the Remote Control Unit

Press the PANEL LIGHT button. All the POSITION buttons and CAMERA buttons light.

To turn off the illumination, press the PANEL LIGHT button again.



Operating Multiple Cameras

Before operating, you must assign the camera addresses to the connected cameras as follows. Then you can switch the camera to be controlled simply by pressing the corresponding CAMERA button.

To assign camera addresses automatically

- 1 Make sure that the camera address selector on the bottom of each camera is set to “0.”

For setting the camera address selector, see page 19.

- 2 Turn on the power of all the connected cameras and the RM-BR300 Remote Control Unit.

- 3 Hold down the RESET button and press the POWER button on the Remote Control Unit. The Remote Control Unit recognizes the connected cameras and assigns them camera addresses 1 to 7 automatically in the connected order.
- 4 Press the POWER button on the Remote Control Unit and check that the CAMERA buttons light. The number of the lit CAMERA buttons indicates how many cameras have the addresses assigned. Now you can switch the camera you want to control with the Remote Control Unit by pressing the CAMERA button.

To assign camera addresses manually

Set one of the camera addresses, 1 to 7, using the camera address selectors on the bottom of each camera.

For setting the camera address selectors, see page 19.

Pan/Tilt and Zoom Operation

Panning and Tilting

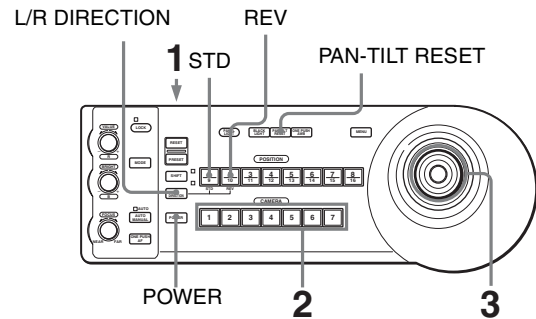

- 1 Turn on the power of the camera and the RM-BR300 Remote Control Unit. The camera will turn on, performing the pan/tilt reset action automatically.
- 2 Press the CAMERA button corresponding to the camera you want to operate.
- 3 Operate the joystick to pan or tilt the camera. While checking the picture on the screen, incline the joystick in the desired direction. The panning/tilting speed changes according to the angle at which you incline the joystick. Release the joystick to stop panning/tilting.

To face the camera back to the front

Press the button on the top of the joystick for one or two seconds.

Press for 1 or 2 seconds.

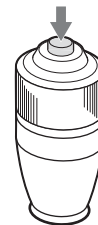



If you accidentally move the camera with your hand



Press the PAN-TILT RESET button to perform the pan/tilt reset action.

If the camera moves in a different direction from that you intended

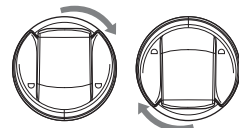
The camera is preset to face toward the right whenever the joystick is inclined to the right. You might wish to face the camera toward the opposite direction from that in which you inclined the joystick, for example, when you change the direction of the camera while checking the picture on the screen. In such a case, press the POSITION 2 (REV) button while holding down the L/R DIRECTION button.

To reset the setting, press the POSITION 1 (STD) button while holding down the L/R DIRECTION button.

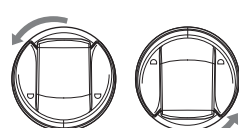
| Joystick | Movement of the camera | Setting |
|---|---|---|
| Incline to the right. | While holding down | L/R DIRECTION |
|  |  |  |
| | | Press. |

| | | |
|--|--|---|
| Incline to the right. | While holding down | L/R DIRECTION |
|  |  |  |
| | | Press. |

Note

The setting above only changes the signal emitted from the RM-BR300 Remote Control Unit, and does not change the setting of the camera itself.

If the STANDBY lamp of the camera flashes

When the camera is moved or turned by hand or by external shock, the microcomputer inside the camera may not be able to memorize the pan/tilt position properly.

To reset the pan/tilt position, press the PAN-TILT RESET button.

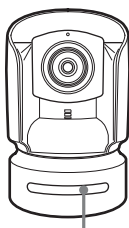

STANDBY flashes.

Zooming

Turn the dial on the upper part of the joystick.

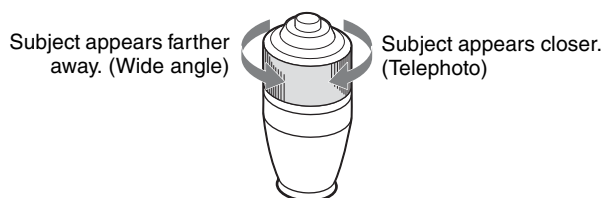

Note

When you perform pan/tilt operation while the camera is in the telephoto mode, the moving speed of the image on the screen may be a little jerky.

Adjusting the Camera

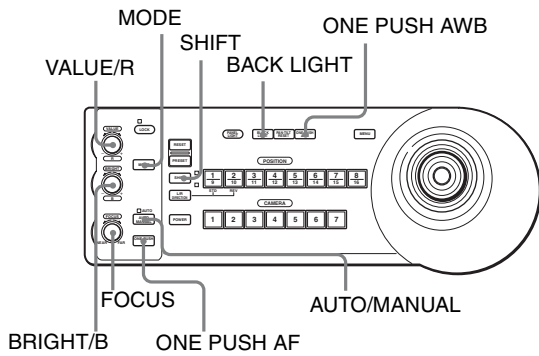

Focusing on a Subject

To focus the camera on a subject automatically

Press the AUTO/MANUAL button so that the AUTO indicator lights. The camera focuses on the subject in the center of the screen automatically.



To focus the camera on a subject manually

Press the AUTO/MANUAL button so that the AUTO indicator turns off. Then turn the FOCUS control clockwise or counterclockwise to have the camera focus on the subject.

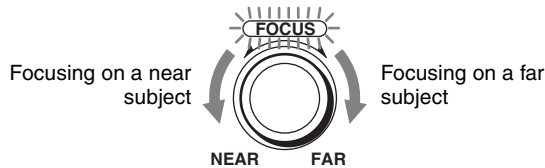

One-push auto focusing during manual focus adjustment

Press the ONE PUSH AF button. The camera focuses on the subject in the center of the screen automatically.



Shooting with Back Lighting

When you shoot a subject with a light source behind it, the subject becomes dark. In such a case, press the BACK LIGHT button.

To cancel the function, press the BACK LIGHT button again.



Note

The BACK LIGHT function is not effective if MODE is set to MANUAL in the EXPOSURE menu of the camera.

Shooting with spotlight compensation

If a portion of the shooting object is illuminated, the spotlight compensation function adjusts the exposure to a darker level. Hold down the SHIFT button and press the BACK LIGHT button.

To cancel the function, hold down the SHIFT button and press the BACK LIGHT button again.

Note

The backlighting and spotlight compensation functions cannot be used simultaneously.

Adjusting the White Balance

Before adjusting the white balance, shoot a white object under the same lighting conditions as the subject you want to shoot, and zoom it in on the screen. (You can use a white wall, etc., instead of the object.)

To adjust the white balance automatically

- 1 Set WHITE BALANCE to ONE PUSH in the COLOR menu of the camera.

For setting, see "COLOR Menu" on page 31.

- 2 Press the ONE PUSH AWB button. The white balance is adjusted automatically.



To adjust the white balance manually

- 1 Set WHITE BALANCE to MANUAL in the COLOR menu of the camera.

For setting, see "COLOR Menu" on page 31.

2 Press the MODE button so that the R and B indicators on the VALUE/R and BRIGHT/B controls light (White balance adjustment mode).

3 Adjust the red gain with the R control and the blue gain with the B control.

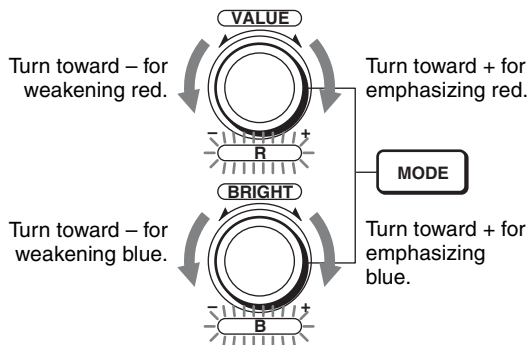

Functions of the R and B controls

When the white balance adjustment mode is selected with the MODE button on the Remote Control Unit, the functions of the R control and B control change according to the WHITE BALANCE setting in the COLOR menu of the camera.

| WHITE BALANCE setting | R control | B control |
|-----------------------|------------------|-------------------|
| MANUAL | Red gain control | Blue gain control |
| AUTO, ONE PUSH | WB SHIFT control | WB SHIFT control |

For details on the WB SHIFT (white balance shift) control, see “WHITE BALANCE” on page 31.

Adjusting the Brightness

1 Set MODE to SHUTTER Pri, IRIS Pri, GAIN Pri or MANUAL in the EXPOSURE menu of the camera.

For setting, see “EXPOSURE Menu” on page 30.

2 Press the MODE button so that the VALUE and BRIGHT indicators on the VALUE/R and BRIGHT/B controls light (Brightness adjustment mode).

3 Adjust the brightness with the VALUE or BRIGHT control.

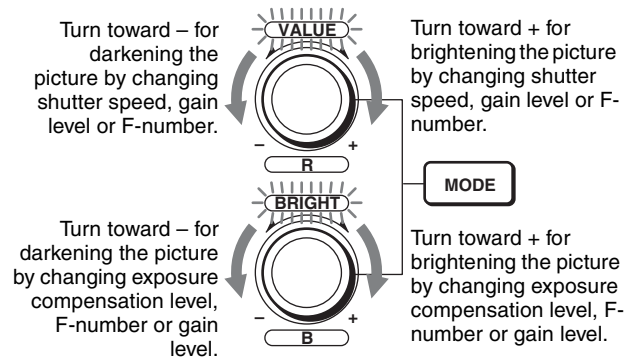

Functions of the VALUE and BRIGHT controls

The functions of the VALUE control and the BRIGHT control change according to the MODE setting in the EXPOSURE menu, as follows:

| MODE setting | Function of VALUE control | Function of BRIGHT control |
|--------------|---------------------------|--------------------------------------|
| FULL AUTO | Not used | Exposure compensation level control* |
| SHUTTER Pri | Shutter speed control | Exposure compensation level control* |
| IRIS Pri | F-number control | Exposure compensation level control* |
| GAIN Pri | Gain control | Not used |
| MANUAL | Shutter speed control | F-number and gain controls |

* When EX-COMP is ON in the EXPOSURE menu

Storing the Camera Settings in Memory

– Presetting Feature

Up to sixteen combinations of settings (sixteen positions), including camera position, zooming, focusing, and backlighting, can be stored in the memory of the camera using the RM-BR300 Remote Control Unit.

For details of the camera settings to be preset, see “Presetting Items” on page 74.

Storing Camera Settings

To select positions 9 to 16

While holding down the SHIFT button, press the PRESET button (to store the settings) or the RESET button (to cancel the settings). The lower indicator on the SHIFT button will light and the POSITION 1 to 8 buttons can be used for positions 9 to 16.

When you release the SHIFT button, the upper indicator lights and the POSITION 1 to 8 buttons can be used for positions 1 to 8.

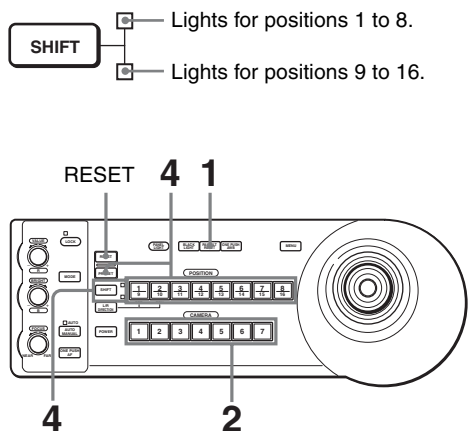

- 1** Press the PAN-TILT RESET button to reset the pan/tilt position.
- 2** Press the CAMERA button to select the camera whose settings you want to preset.
- 3** Adjust the position, zooming, focusing and backlighting of the camera. (See page 44 to 47.)
- 4** While holding down the PRESET button (for POSITION 1 to 8) or the SHIFT and PRESET buttons (for POSITION 9 to 16), press any of the

POSITION buttons in which you want to store the settings.

While holding down (for POSITION 1 to 8)

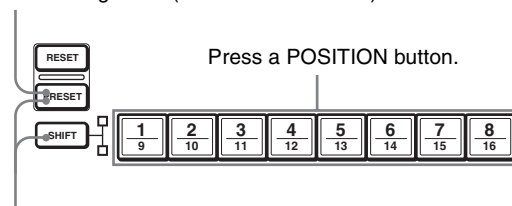

While holding down (for POSITION 9 to 16)

The settings are stored in the memory of the camera.

The pressed button flashes during storing. Flashing stops when storing is completed.

To recall the stored settings

Press any of the POSITION buttons in which you have stored the settings.

For POSITION 9 to 16, hold down the SHIFT button and press any of the POSITION buttons.

To cancel the preset memory

While holding down the RESET button (for POSITION 1 to 8) or the SHIFT and RESET buttons (for POSITION 9 to 16), press the POSITION button from which you want to cancel the settings.

While holding down (for POSITION 1 to 8)

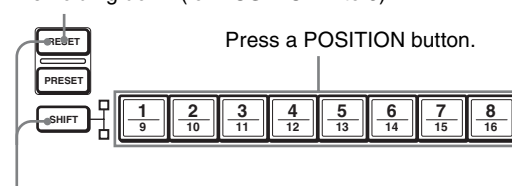

While holding down (for POSITION 9 to 16)

The pressed button flashes during canceling of the settings. Flashing stops when the settings have been canceled.

Notes

- When the power is turned on, the camera starts with the settings stored in POSITION 1.
- If you want to retain the previous pan and tilt positions when the power is turned off and turned on again, store those positions in POSITION 1.
- When you are storing or canceling the settings in one POSITION, you cannot call up, store or cancel the settings in another POSITION.

Setting the Speed of the Camera Moving to a Preset Position

You can select the panning/tilting speed when the camera moves to a preset position.

- 1** Press the CAMERA button to select the camera whose speed you want to set.
- 2** Press the POSITION button for which you want to set the speed for more than one second.
All the CAMERA buttons, 1 to 7, flash.
- 3** Press one of the CAMERA buttons to select the speed.

| CAMERA button | Panning/tilting speed |
|---------------|---------------------------|
| 1 | 1 degree/sec. |
| 2 | 2.2 degrees/sec. |
| 3 | 4.8 degrees/sec. |
| 4 | 11 degrees/sec. |
| 5 | 23.3 degrees/sec. |
| 6 | 43 degrees/sec. |
| 7 | 60 degrees/sec. (default) |

Now the camera will move to the position preset to the pressed POSITION button with the selected speed.

To set the speed of the camera moving to a preset position between 9 and 16

Hold down the SHIFT button and press the corresponding POSITION button for more than one second.



Installation

Removing/Attaching the Cable Cover

To remove the cable cover

The cable cover is attached to the camera at the factory. You can remove it, if necessary.

- 1 Release the two screws on the cable cover.

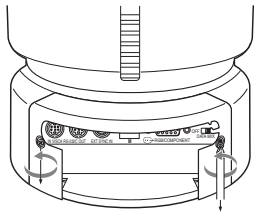

- 2 Hold the lower ends of the cable cover and pull it toward you.

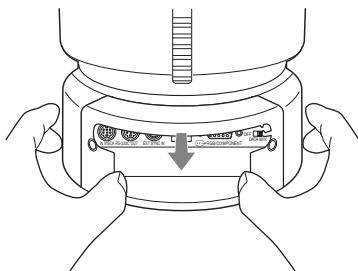

To attach the cable cover

- 1 Insert the projections on the upper ends of the cover into the camera, then push in the cover at both ends.

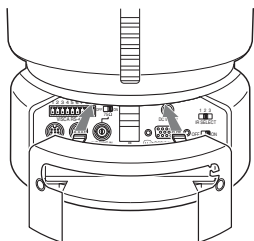

- 2 Tighten the two screws on both ends of the cover.

Note

Never carry the camera by holding the cable cover.

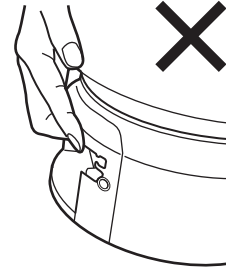

Attaching an Interface Board

Attach an interface board (not supplied) to the card slot on the rear of the camera.

- 1 Loosen the two screws to remove the card slot cover.

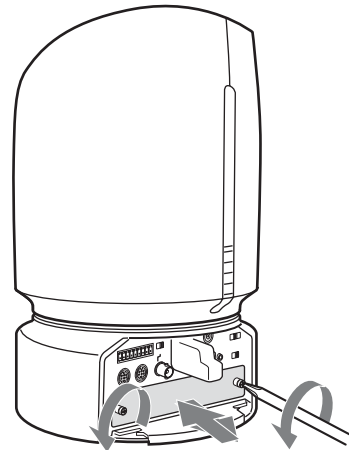

- 2** Insert an optional interface board into the card slot. Align both ends of the interface board with the sliders inside the slot, then insert the board securely as far as it will go.

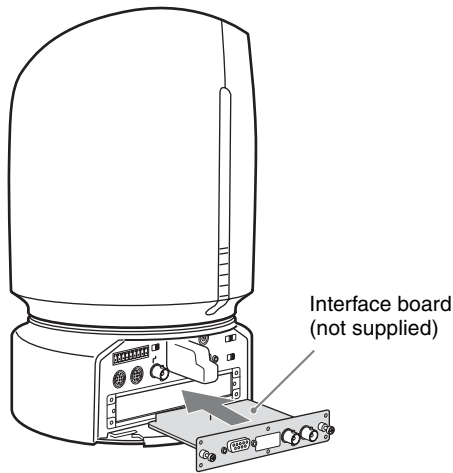

- 3** Tighten the two screws on the interface board.

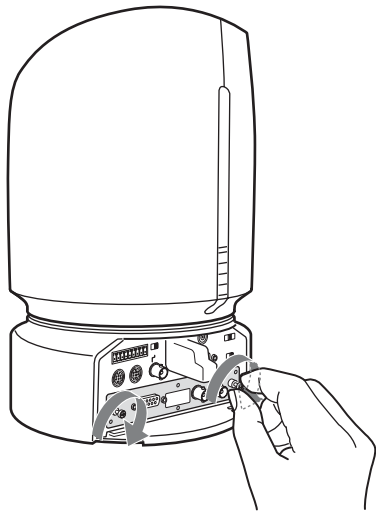

To remove the interface board

Loosen the two screws on the interface board and pull the board out straight and slowly.

Installing the Camera

To install the camera on a desk

Place the camera on a flat surface.

If you have to place the camera on an inclined surface, make sure that the inclination is less than ± 15 degrees, so that the pan/tilt performance is guaranteed.

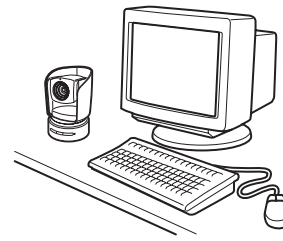

Notes

- You should take an appropriate countermeasure to prevent the camera from falling.
- Do not grasp the camera head when carrying the camera.
- Do not turn the camera head by hand. Doing so may result in the camera malfunctioning.

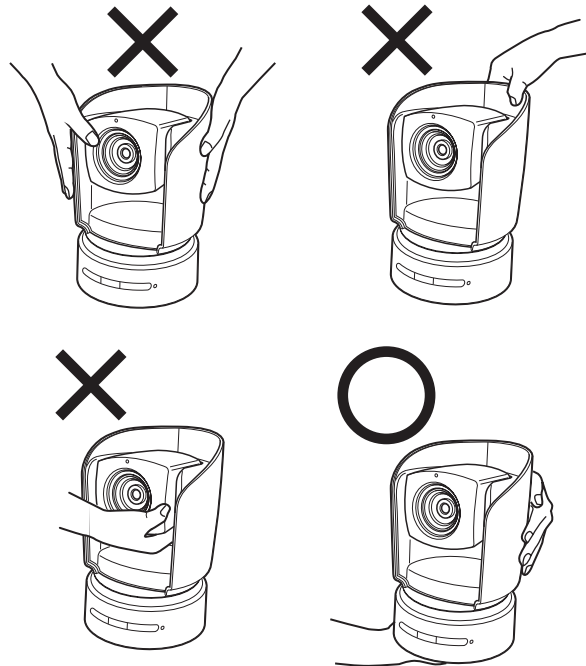

To attach the camera to a tripod

Attach a tripod to the screw hole used for attaching a tripod on the bottom of the camera.

The tripod must be set up on a flat surface and tightened firmly by hand.

Use a tripod with screws of the following specifications.

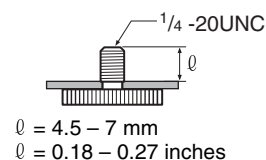

Caution

Installation of the camera using the tripod screws and screw holes should not be done for installation on a ceiling or a shelf, etc. in a high position.

Installing the Camera in a High Position

Using the supplied ceiling brackets, wire rope and screws, and the attachment materials (not supplied), you can attach the camera to a ceiling or on a shelf, etc. in a high position.

When you install the camera, always install it on a level ceiling or shelf, etc. If you have to install it on an incline, make sure that the inclination is within ± 15 degrees, so that the pan/tilt performance is guaranteed.

Caution

- When you attach the camera to a ceiling or shelf, etc. in a high position, entrust the installation to an experienced contractor or installer.
- Attach the camera to the ceiling or shelf, etc. firmly, after making sure the ceiling, shelf, etc. and the attachment materials (not including the supplied accessories) are strong enough to bear a weight of 60 kg (132 lb 4 oz). If the ceiling or shelf, etc. is not strong enough, the camera may fall and cause serious injury.
- Be sure to attach the supplied wire rope to prevent the camera from falling.
- Check periodically, at least once a year, to ensure that the connection has not loosened. If conditions warrant, make this periodic check more frequently.

Before installation

After deciding the shooting direction, make the required holes for the ceiling bracket (B) and connecting cables on the ceiling or shelf, etc. For the dimensions of the ceiling bracket (B), see page 77.

Notes

- The connecting cables cannot be passed through the ceiling bracket (A). A hole for the wiring is required in the ceiling or on a shelf, etc. behind where the camera is to be installed.
- Do not attach any object other than the camera to the ceiling brackets.
- The ceiling bracket cannot be attached to the junction box when installing the camera on a ceiling.

Installation on a ceiling (example)

- 1 Remove the cable cover on the rear of the camera. For details on how to remove it, see “To remove the cable cover” on page 50.
- 2 Set IMG-FLIP to ON in the SYSTEM menu.
- 3 Remove the four screws on the bottom of the camera to remove the four feet.

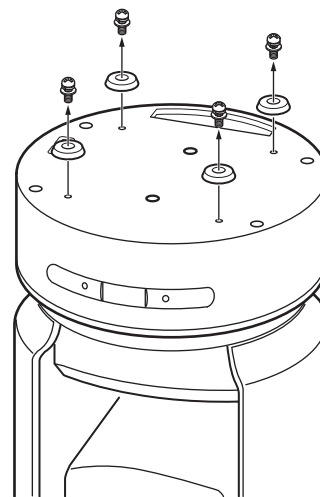

- 4 Attach the ceiling bracket (A) to the bottom of the camera using the supplied four screws ($\oplus M3 \times 8$). Position the Δ hole on the ceiling bracket (A) to the front of the camera, align the screw holes on the ceiling bracket with those on the bottom of the camera, then attach the bracket to the camera.

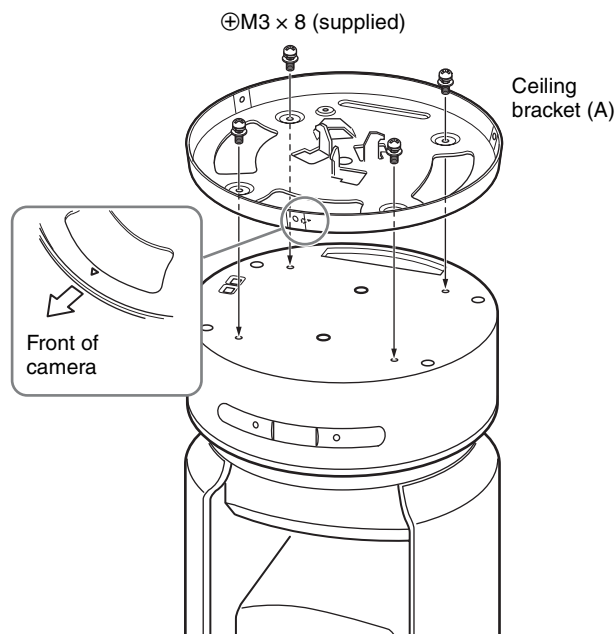

Note

For attaching the camera to the ceiling bracket, use only the supplied screws. Using other screws may damage the camera.

- 5** Attach the attachment materials (not supplied) to the ceiling bracket (B), and install the bracket on the ceiling. Align the Δ hole on the ceiling bracket (B) in the direction where the front of the camera will be positioned later.

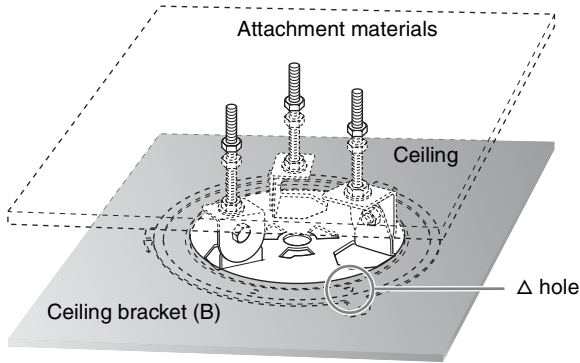

- 6** Attach the wire rope to the materials near the ceiling. Use an M5 (3/16 inch) hexagon socket head cap screw (not supplied). Attach the wire rope to an area independent of the area where the ceiling bracket is attached.

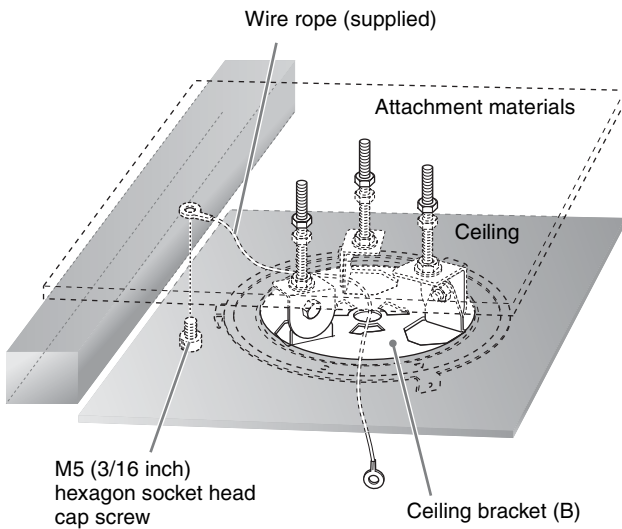

- 7** Attach the wire rope to the ceiling bracket (A). Pass the wire rope through the fixing hole and attach its end to the attachment hole on the bracket using the supplied one screw ($\oplus M4 \times 8$).

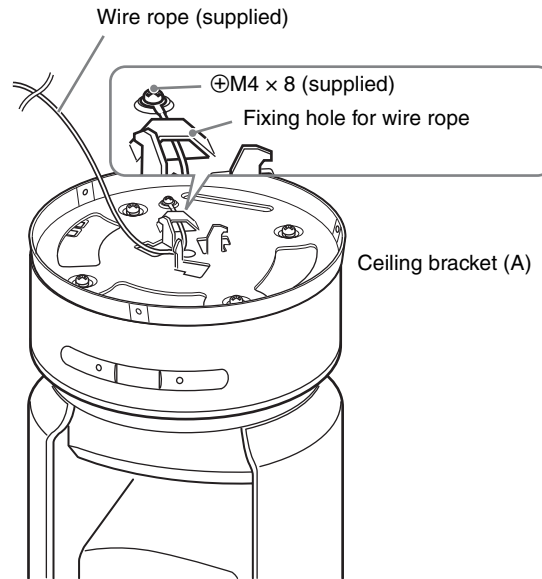

Caution

For attaching the wire rope to the bracket, use only the supplied screw. Using another screw may disable the function of the wire rope.

- 8** Insert the protrusions on the ceiling bracket (A) into the spaces prepared in the ceiling bracket (B) with the Δ hole on the ceiling bracket (A) aligned with the \square hole on the ceiling bracket (B), and temporarily attach them by turning the ceiling bracket (A) with the camera clockwise.

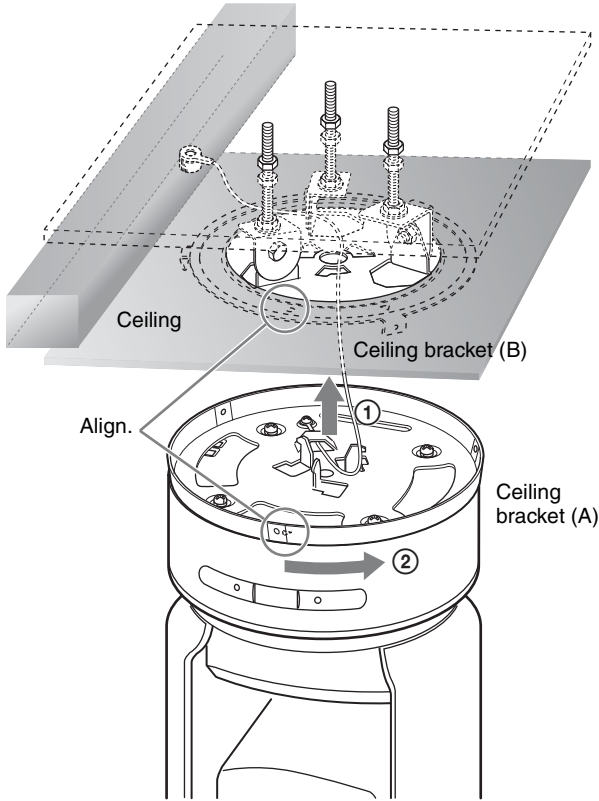

- 9** Secure the ceiling brackets (A) and (B) using the supplied three screws (\oplus M3 \times 8).

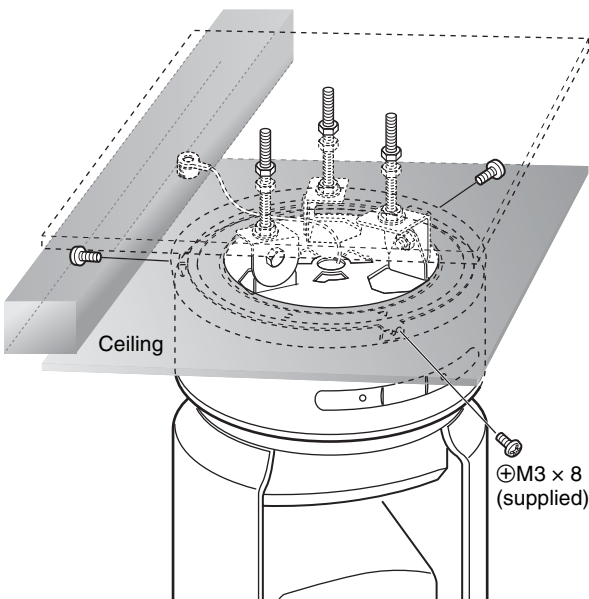

- 10** Connect the cables to the connectors on the rear of the camera.

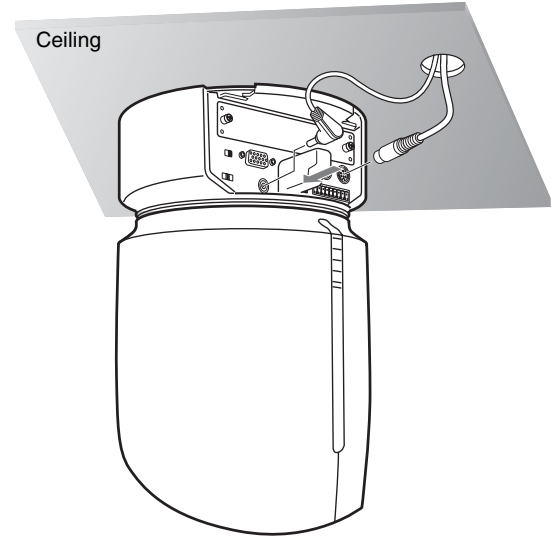

Note

Take the proper steps to ensure that the load of the cables connected does not cause problems.

- 11** Attach the cable cover.
For attachment, see page 50.
The SONY and/or HD nameplates can be turned upside down, if necessary.

To remove the camera

- 1** Remove the three screws used to attach the camera in step 9 of “Installation on a ceiling (example).”
- 2** Turn the camera with the bracket counterclockwise to remove.

Installation on a shelf, etc. in a high position (example)

- 1** Remove the cable cover on the rear of the camera.
For details on how to remove it, see “To remove the cable cover” on page 50.

- 2** Remove the four screws on the bottom of the camera to remove the four feet.

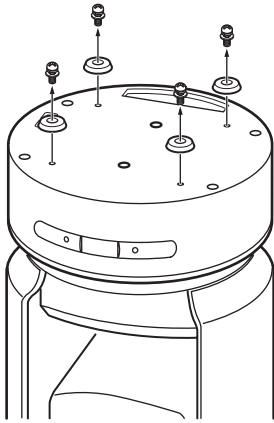

- 3** Attach the ceiling bracket (A) to the bottom of the camera using the supplied four screws (⊕M3 × 8). Position the Δ hole on the ceiling bracket (A) to the front of the camera, align the screw holes on the ceiling bracket with those on the bottom of the camera, then attach the bracket to the camera.

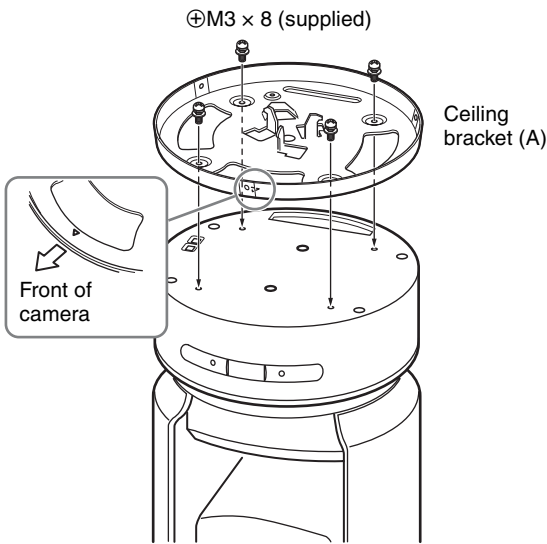

Note

For attaching the camera to the ceiling bracket, use only the supplied screws. Using other screws may damage the camera.

- 4** Attach the supplied wire rope to the ceiling bracket (A). Pass the wire rope through the fixing hole and attach its end to the attachment hole on the bracket using the supplied one screw (⊕M4 × 8).

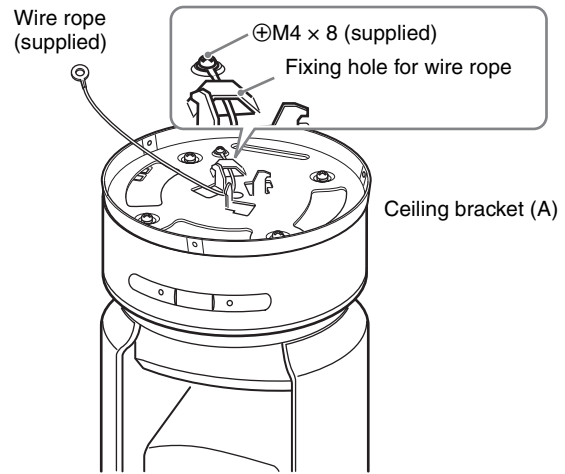

Caution
For attaching the wire rope to the bracket, use only the supplied screw. Using another screw may disable the function of the wire rope.

- 5** Attach the ceiling bracket (B) to a shelf, etc. on which the camera is to be installed. Use four screws (not supplied) appropriate for the materials of the shelf, etc. Align the Δ hole on the ceiling bracket (B) in the direction where the front of the camera will be positioned later.

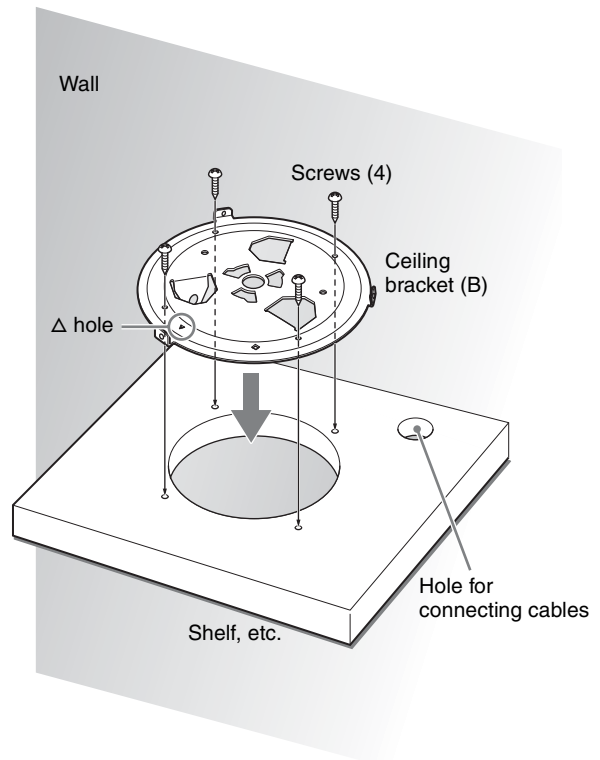

- 6** Attach the other end of the wire rope to the material near the shelf, etc. Use an M5 (3/16 inch) hexagon socket head cap screw (not supplied). Attach the wire rope to the material independent of the shelf, etc. where the ceiling bracket (B) is attached.

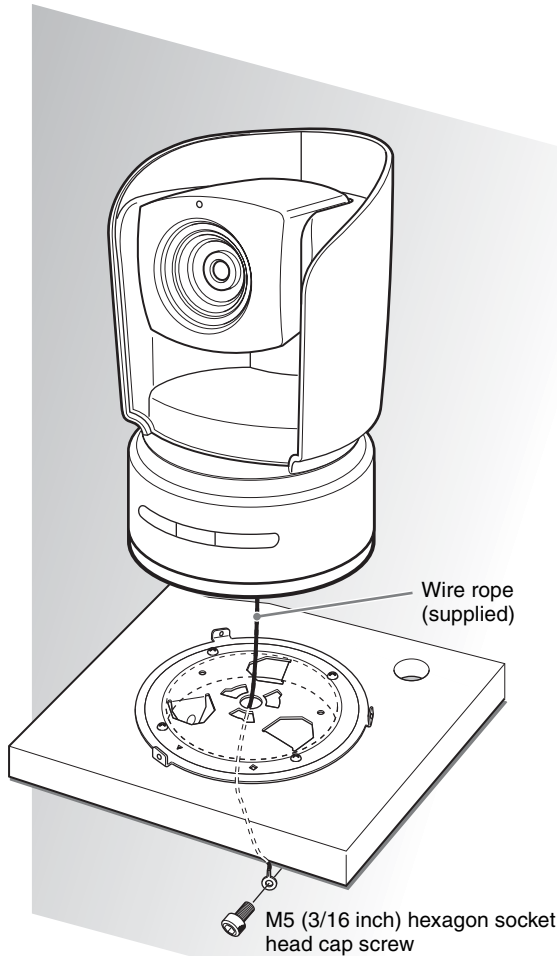

- 7** Insert the protrusions on the ceiling bracket (A) into the spaces prepared in the ceiling bracket (B) with the Δ hole on the ceiling bracket (A) aligned with the \square hole on the ceiling bracket (B), and temporarily attach them by turning the ceiling bracket (A) with the camera counterclockwise.

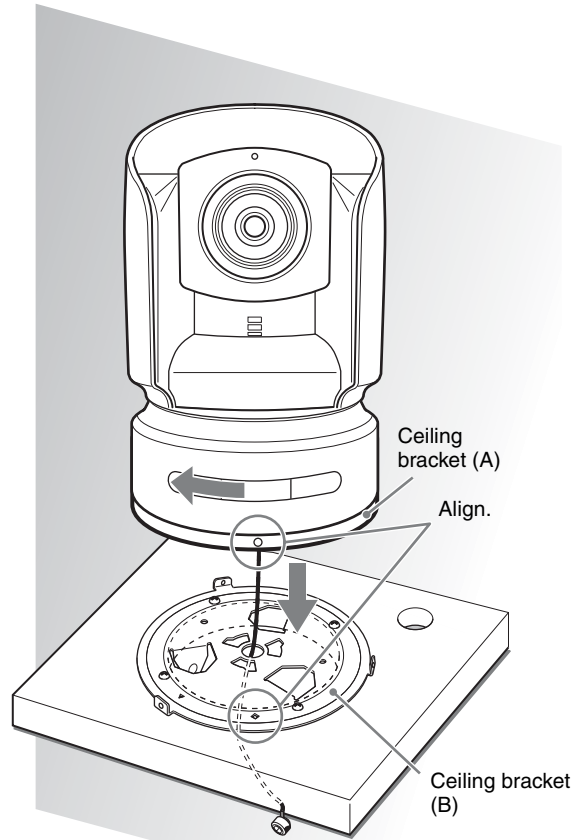

- 8** Secure the ceiling brackets (A) and (B) using the supplied three screws (\oplus M3 \times 8).

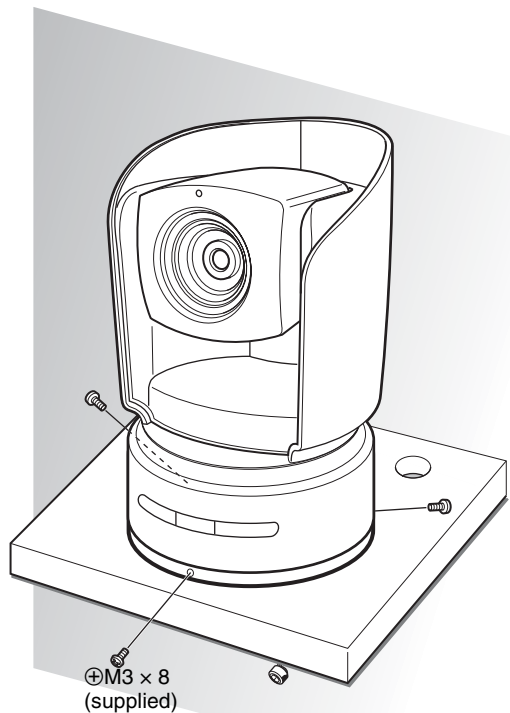

- 9 Connect the cables to the connectors on the rear of the camera.

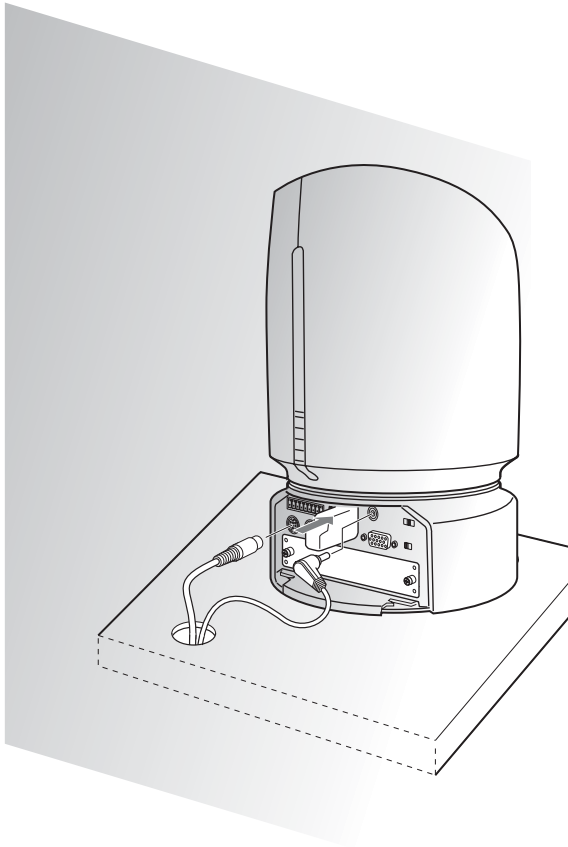

Note

Take the proper steps to ensure that the load of the cables connected does not cause problems.

- 10 Attach the cable cover.
For attachment, see page 50.

To remove the camera

- 1 Remove the three screws used to attach the camera in step 8 of “Installation on a shelf, etc. in a high position (example).”
- 2 Turn the camera with the bracket clockwise to remove.

Connections

Connecting to an AC Outlet

Use the supplied AC power adaptor and AC power cord to connect the camera to an AC outlet.

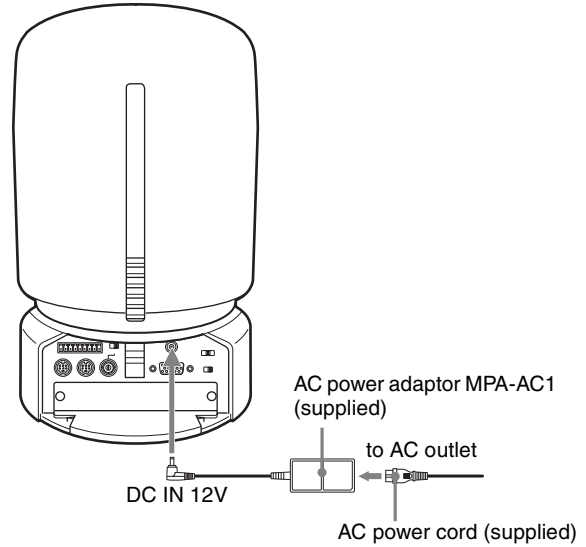

Connecting the RM-BR300 Remote Control Unit

Use the RS-232C connecting cable supplied with the Remote Control Unit.

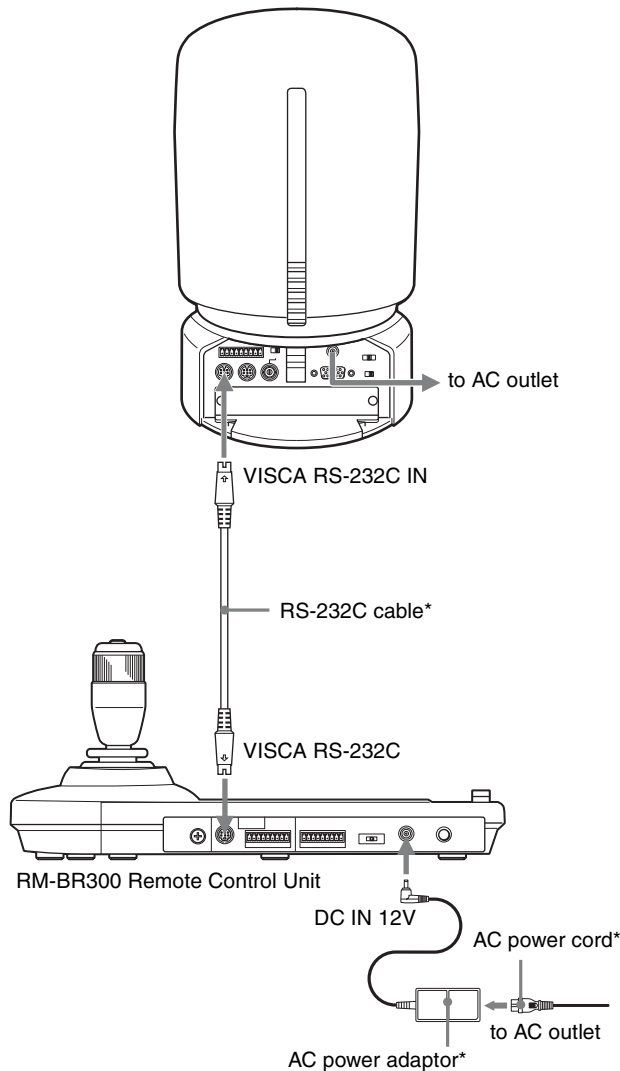

* supplied with the RM-BR300

Note

When using the VISCA RS-232C connectors, check that the **BOTTOM** switch on the bottom of the camera (page 19) and the DIP switch on the bottom of the Remote Control Unit (page 23) are set to RS-232C.

To connect the Remote Control Unit using the VISCA RS-422 connectors

You can use the VISCA RS-422 connectors to connect the RM-BR300 Remote Control Unit to the camera instead of the VISCA RS-232C connectors. Use of the VISCA RS-422 connectors allows the connection up to 1,200 m (3,937 feet) away.

Prepare the connecting cable using the RS-422 connector plugs that come with the camera and the Remote Control Unit.

For making the cable, refer to the pin assignments of the VISCA RS-422 connector (pages 80 and 81) and the wiring diagram of VISCA RS-422 connection (page 83).

For the use of the RS-422 connector plugs, see back cover.

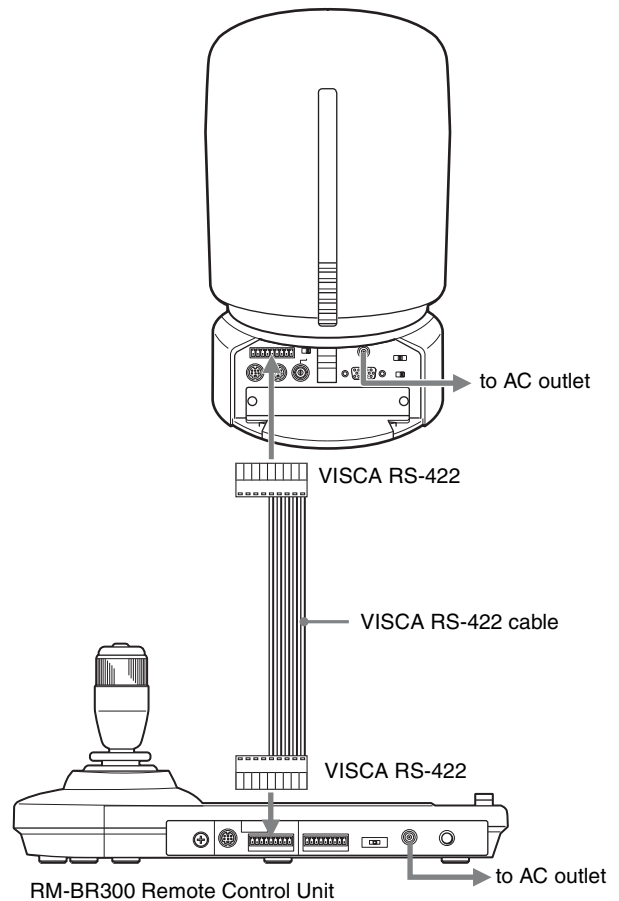

Notes

- When using the VISCA RS-422 connectors, check that the **BOTTOM** switch on the bottom of the camera (page 19) and the DIP switch on the bottom of the Remote Control Unit (page 23) are set to RS-422.
- When the connections using the VISCA RS-422 connectors are made, the VISCA RS-232C connection is not available.

Connecting a Monitor, etc. Equipped with the Analog Component (YPbPr) Input Connector

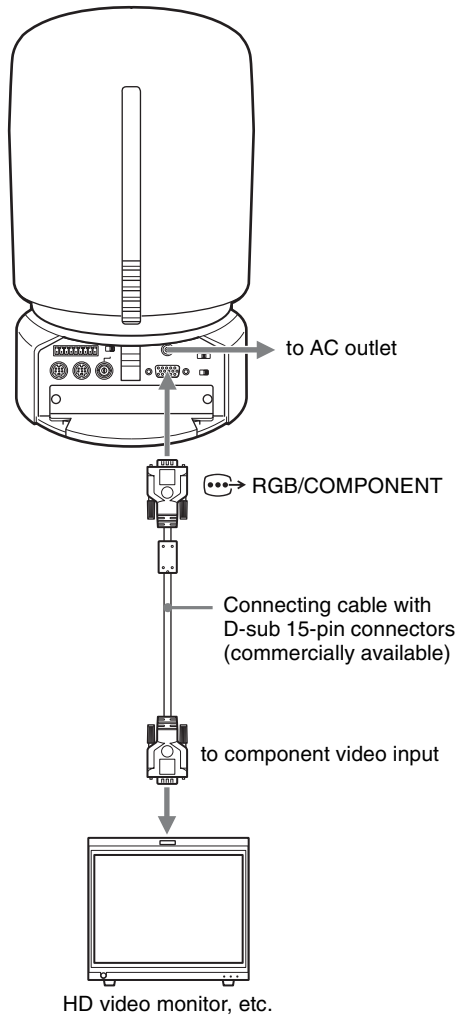

Connecting a Device Equipped with VISCA RS-232C Connector

Connections with the VISCA RS-232C cables (cross type) enable control of multiple cameras with a single RM-BR300 Remote Control Unit.

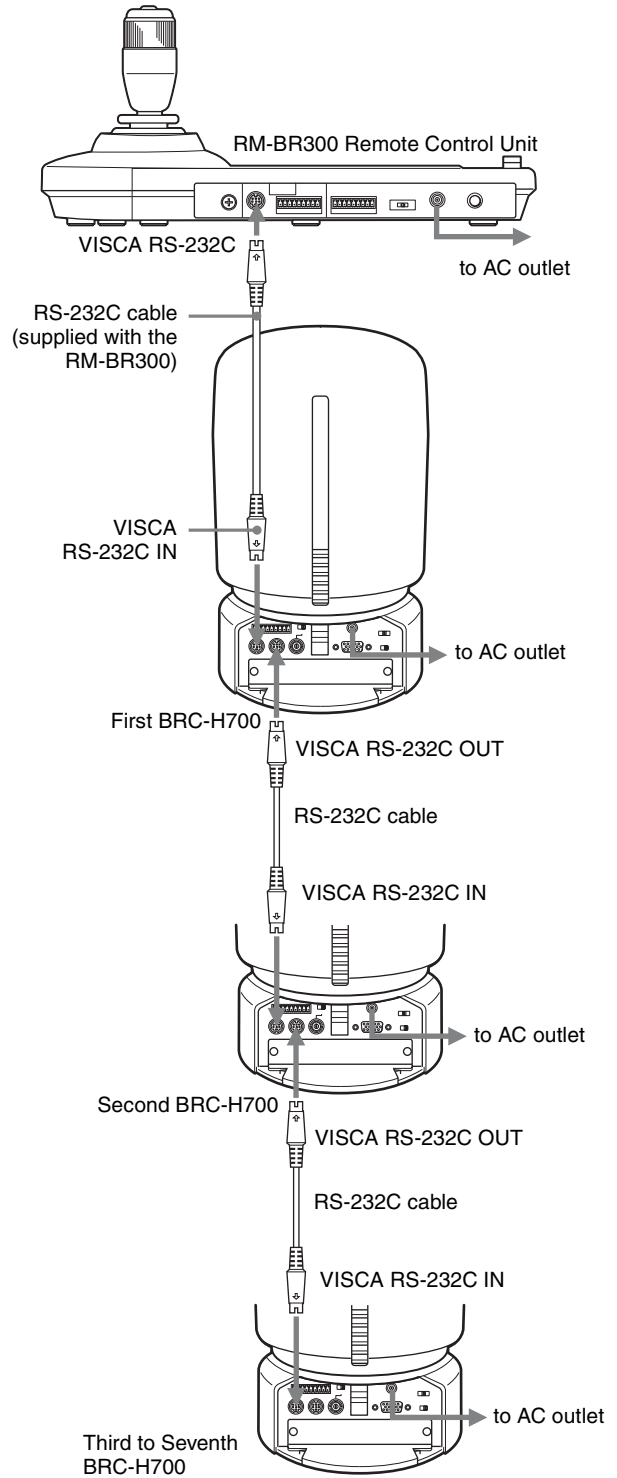

You can connect the camera to a computer equipped with the VISCA RS-232C connector instead of the connection to the RM-BR300 Remote Control Unit.

Note

When using the VISCA RS-232C connectors, check that the BOTTOM switch on the bottom of the camera (page 19) and the DIP switch on the bottom of the Remote Control Unit (page 23) are set to RS-232C.

Connecting a Device Equipped with VISCA RS-422 Connector

Connection via the VISCA RS-422 connectors enables control of multiple cameras. This allows the connection up to 1,200 m (3,937 feet) away.

Prepare the connecting cable using the RS-422 connector plugs that come with the camera and the Remote Control Unit.

For making the cable, refer to the pin assignments of the VISCA RS-422 connector (pages 80 and 81) and the wiring diagram of VISCA RS-422 connection (page 83).

For the use of the RS-422 connector plugs, see back cover.

Notes

- When using the VISCA RS-422 connectors, check that the BOTTOM switch on the bottom of the camera (page 19) and the DIP switch on the bottom of the Remote Control Unit (page 23) are set to RS-422.
- When the connections using the VISCA RS-422 connectors are made, the VISCA RS-232C connection is not available.
- Do not make the VISCA RS-422 connection and the VISCA RS-232C connection simultaneously. If both cables are connected simultaneously, the camera may malfunction.

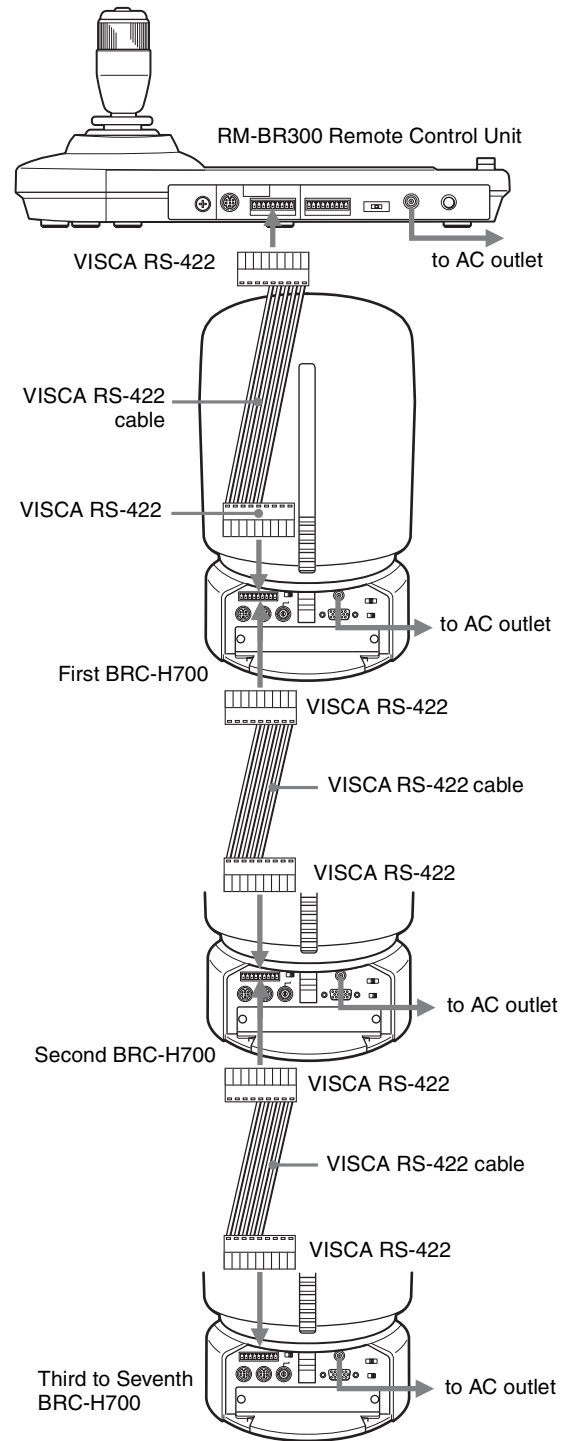

Connecting a Video Monitor Equipped with Analog RGB/Component Connectors

When you install an optional HFBK-SD1 SD Interface Board into the camera, you can output the signal from the camera by converting it into component video, RGB, composite video or S-video signal.

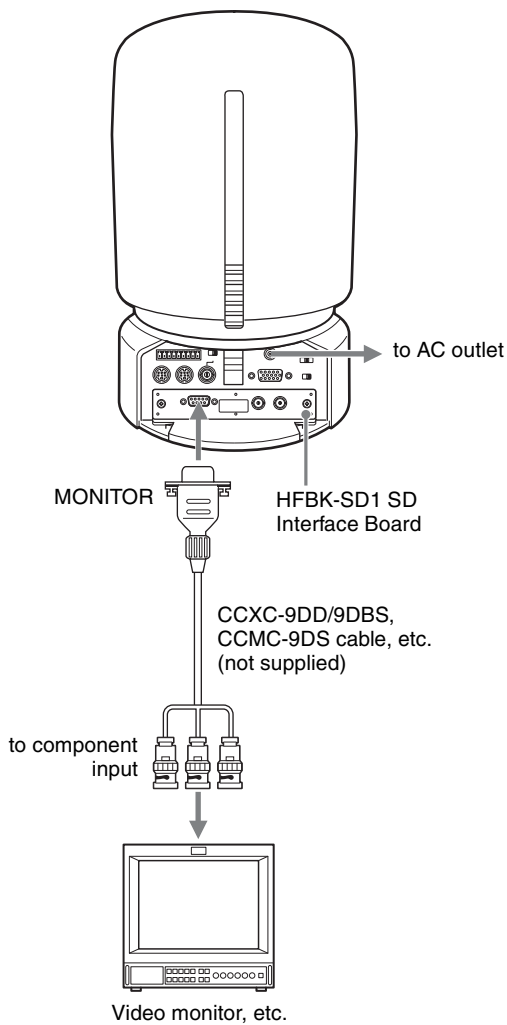

For details on how to attach the HFBK-SD1 SD Interface Board, see page 50.

To select the output signal, use the D-SUB OUT1 and D-SUB OUT2 items in the DOWN CONVERTER menu (page 36).

Connecting a Video Monitor, VTR, etc. Equipped with Composite Video Input Connector

When you install an optional HFBK-SD1 SD Interface Board into the camera, you can output the signal from the camera by converting it into composite video signal.

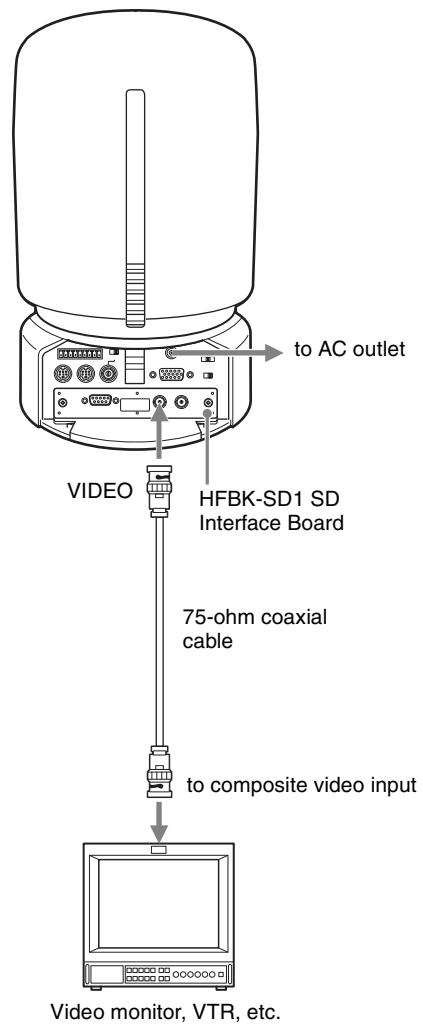

Connecting a VTR Equipped with SDI Input Connector

When you install an optical HFBK-SD1 SD Interface Board in the camera, you can output the signal from the camera by converting it into an SDI signal that conforms to SMPTE259M (for 59.94i signal format) or ITU-R BT.656 (for 50i signal format) serial digital interface standards.

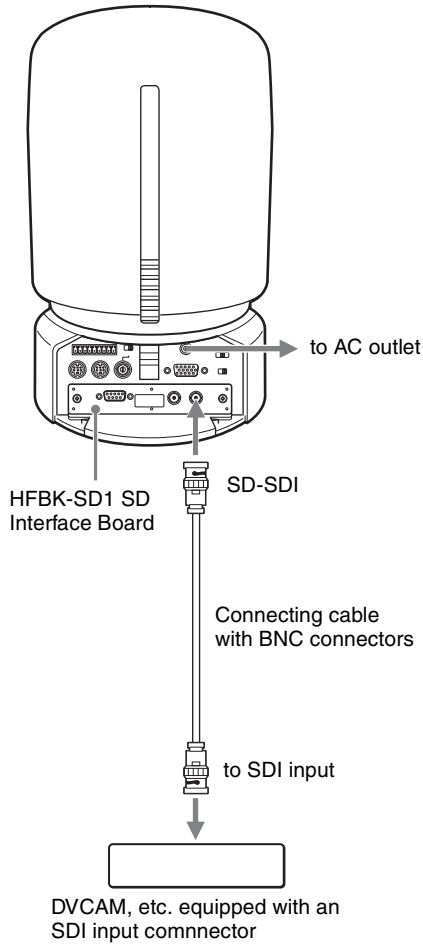

Connecting a VTR Equipped with HD-SDI Input Connectors

When you install an optional HFBK-HD1 HD Interface Board in the camera, you can output the signal from the camera by converting it into a signal compliant with HD-SDI standards (SMPTE292M serial digital interface).

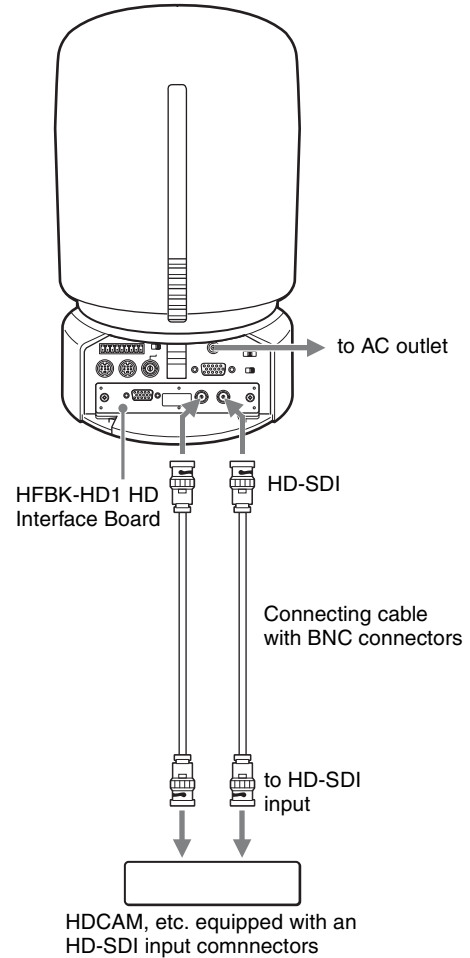

Notes

- When an optional HFBK-SD1 SD Interface Board is installed in the camera, the DIP switches on the board cannot be used. Use the menus of the camera for various settings.
- Signal processing in the interface board causes all output signals from the HFBK-SD1 to be delayed by approximately 93H (horizontal sync time) compared with the YPbPr/RGB output signals from the camera. A similar delay occurs when using an external sync signal.

Notes

- When an optional HFBK-HD1 HD Interface Board is installed in the camera, the DIP switches on the board cannot be used. Use the menus of the camera for various settings.
- Signal processing in the interface board causes all output signals from the HFBK-HD1 to be delayed by approximately 4H (horizontal sync time) compared with the YPbPr/RGB output signals from the camera. A similar delay occurs when using an external sync signal.

Connecting a Computer

When you install an optional HFBK-XG1 XGA Interface Board into the camera, you can output the signal from the camera by converting it into a signal compliant with the VESA (VGA, XGA or WXGA) standards.

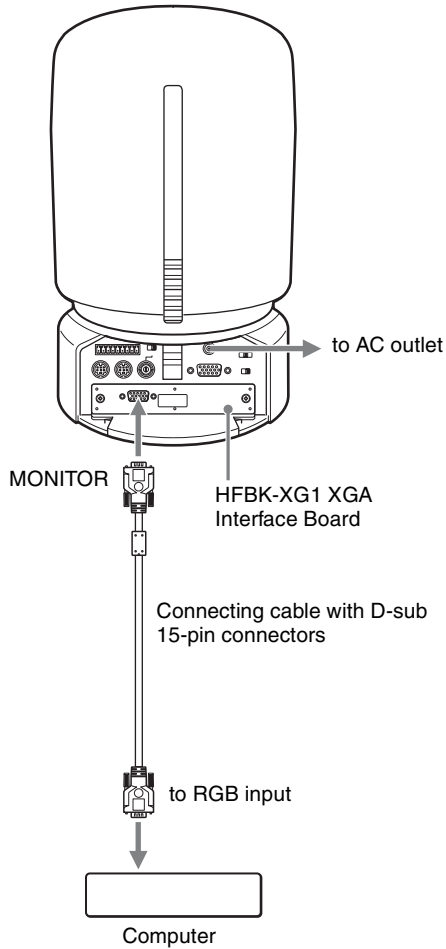

Connecting the BRU-H700 HD Optical Multiplex Unit

When you install an optional BRBK-H700 Optical Multiplex Card in the camera, you can connect the camera to the BRU-H700 Optical Multiplex Unit using the CCFC-M100HG Optical Fiber Cable. This allows you to control the camera from up to 1,000 m (3,281 feet) away.

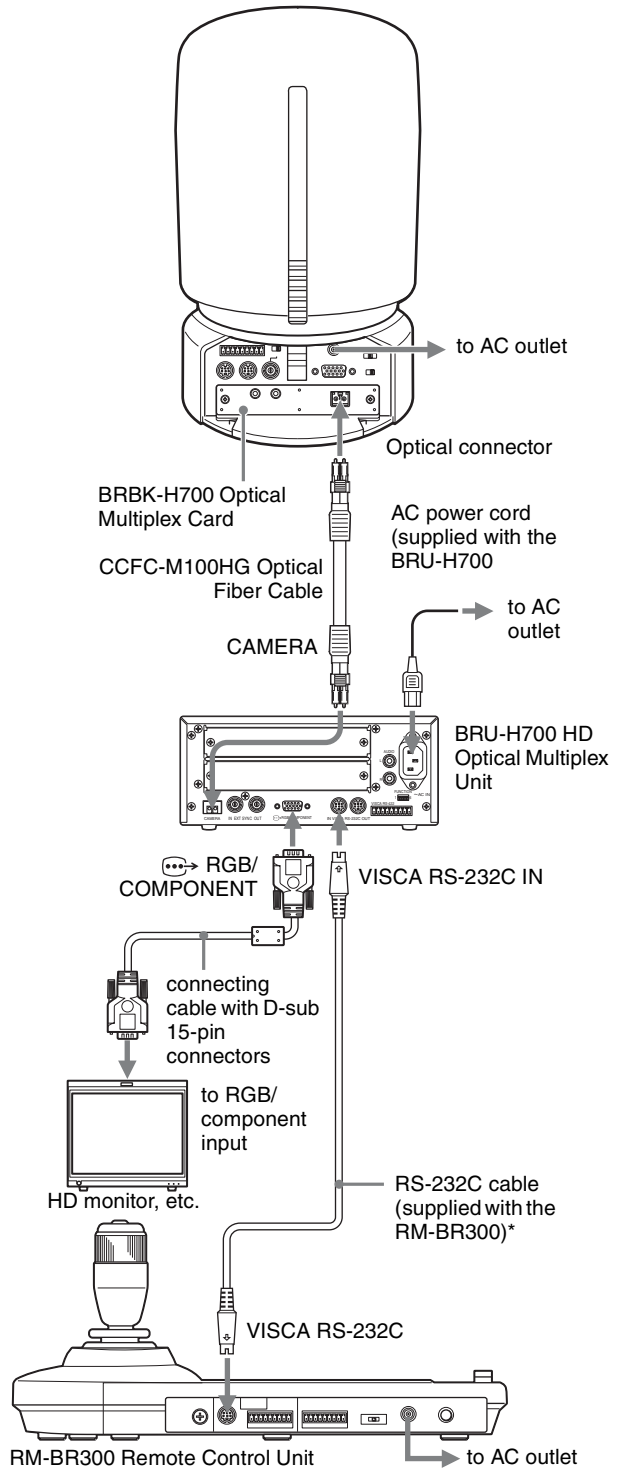

* The VISCA RS-422 connection is also available if you use the VISCA RS-422 connectors.

Notes

- When the connection using the Optical Fiber Cable is made, the VISCA RS-232C and VISCA RS-422 connectors on the camera cannot be used.
- When using the VISCA RS-232C connectors or VISCA RS-422 connectors, check the VISCA

FUNCTION switch on the rear of the Optical Multiplex Unit (page 25) and the DIP switch on the bottom of the Remote Control Unit (page 23) are set to RS-232C or RS-422 correctly.

Notes on use of the CCFC-M100HG HD Optical Fiber Cable

- In order to prevent cable transmission loss, fix the bend in the cable keeping more than 40 mm (1 5/8 inches) radius.

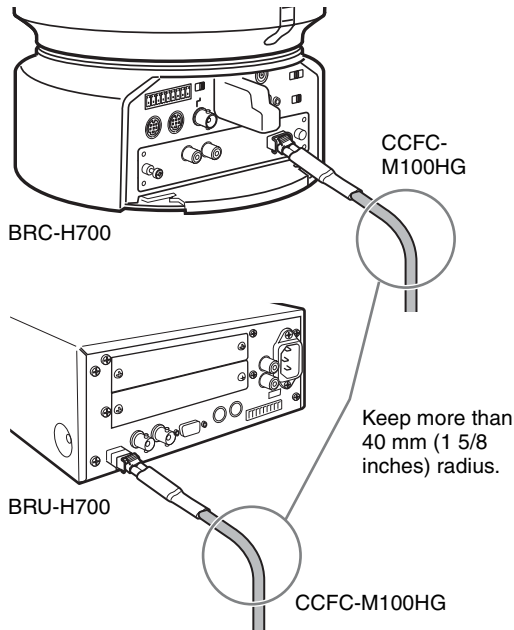

- To connect two Optical Fiber Cables, use the extension plug supplied with the cable.

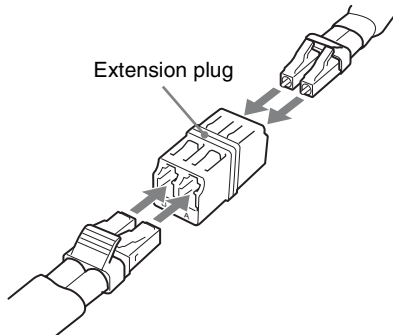

Connecting a Video Switcher

Use a commercially available video switcher to switch between the multiple camera signals to be output.

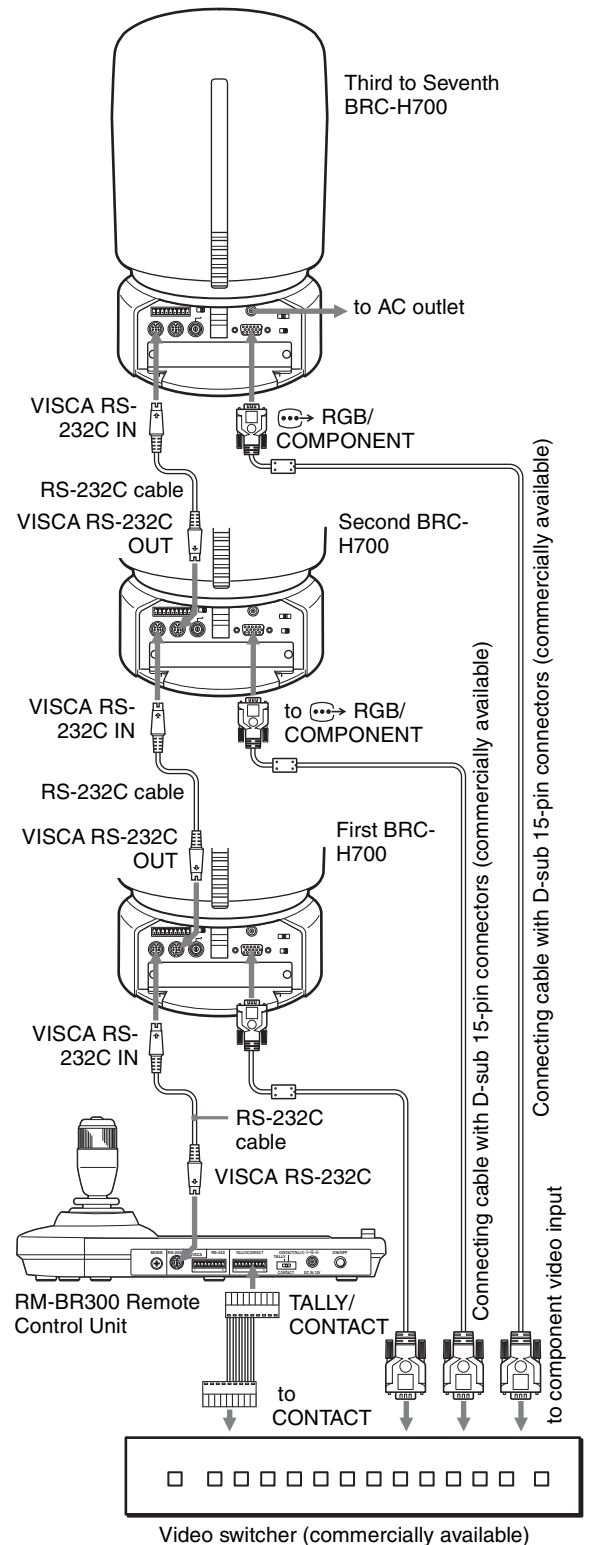

For connection with a video switcher, refer to the Operating Instructions of the switcher.

Connecting a Sync Signal Generator

To connect a single camera

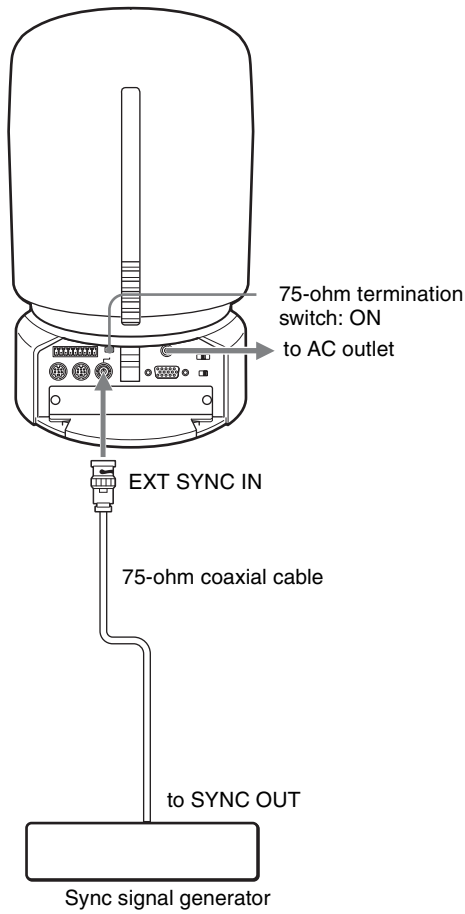

To connect multiple cameras to the HD sync signal generator

You can connect up to seven cameras.

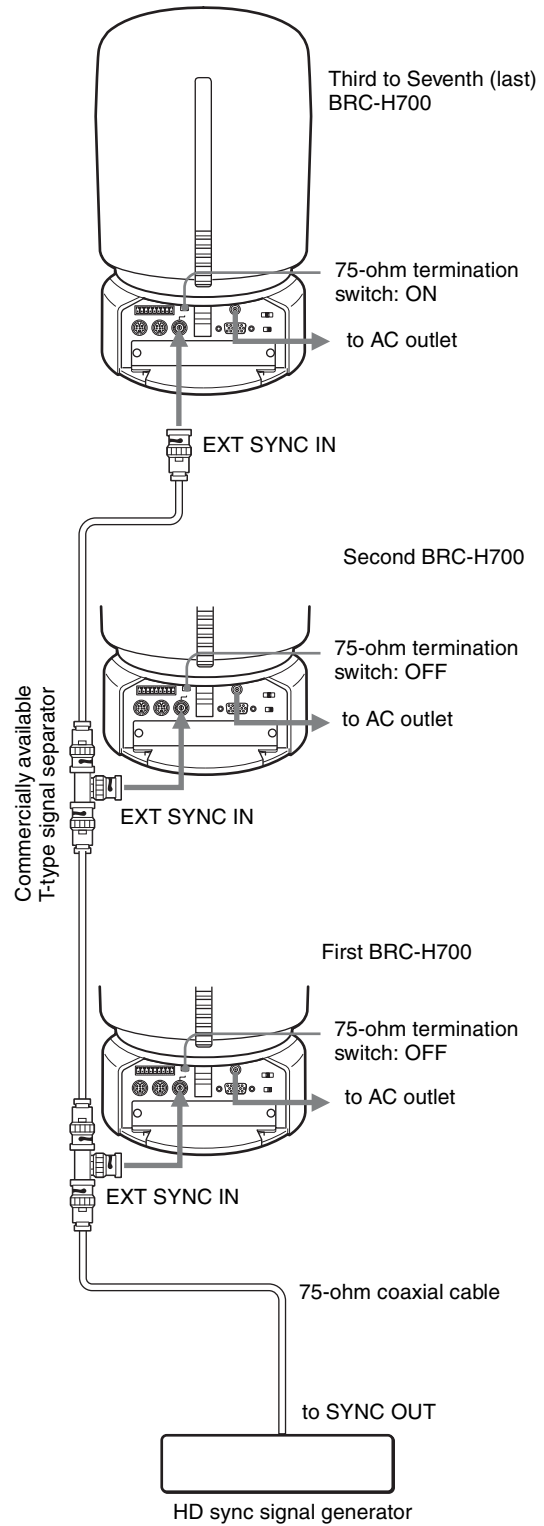

To connect multiple cameras to the SD sync signal generator

You can connect up to seven cameras.

If you want to synchronize the phase between signals output from the HFBK-SD1 and those from an SD sync signal generator, set SYNC MASTER to SD1 in the SYSTEM menu (page 35).

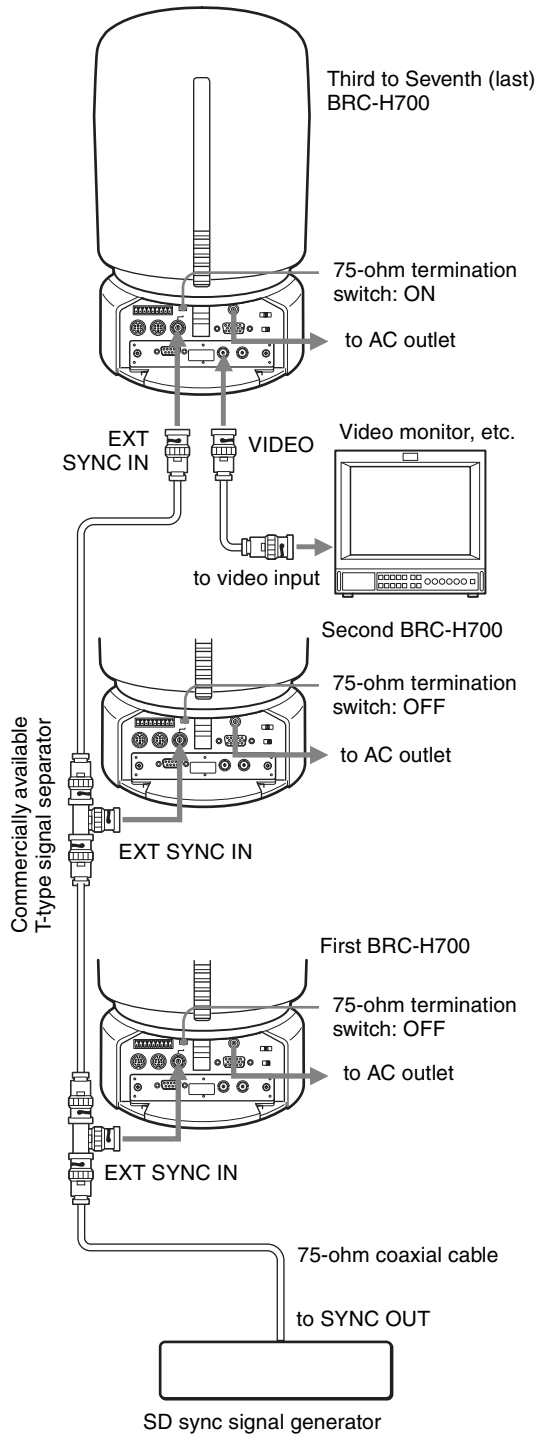

Note

Signal processing in the interface board causes all output signals from the HFBK-SD1 to be delayed by approximately 93H (horizontal sync time) compared with the YPbPr/RGB output signals from the camera.

List of Messages

The following messages may appear on the screen. Take the necessary measures shown below.

Indicators on the BRC-H700 camera

| Indicator | Meaning/remedies |
|-------------------------|--|
| STANDBY lamp flashes. | The camera stopped moving due to an error in the pan/tilt mechanism. Reset the pan/tilt position or turn off the power of the camera and turn it on again. |
| The tally lamp flashes. | Turn off the power of the camera, and consult with your Sony dealer. |

Messages for the BRC-H700 camera

| Message | Meaning/remedies |
|--|--|
| Please restart system | You are prompted to restart the power of the camera after you changed the setting of "IMG-FLIP" in the SYSTEM menu. Use the POWER switch on the supplied Remote Commander or the POWER button on the RM-BR300 Remote Control Unit to turn the power off, then on. The changed setting becomes effective. |
| PRESET xx OK (xx = 1 to 16) | When you store the camera settings into the memory (POSITION 1-16), the message will appear for 2 seconds. |
| One Push WB...OK (NG) | While the white balance is automatically adjusted, the message will appear. Wait for a while. When the adjustment is complete, it will disappear. |
|  STOP (The message will flash in FAN MOTOR on PAGE5 in the STATUS menu.) | Turn off the power of the camera, and consult with your Sony dealer. |
| CAUTION COOLING FAN 1 (2), (1, 2) STOPPED! | Turn off the power of the camera, and consult with your Sony dealer. |

Error messages for the BRU-H700 HD Optical Multiplex Unit

| Message | Meaning/remedies |
|--|--|
| Communication error Please check connection | The message will appear when the HD Optical Multiplex Unit is turned on, if a problem occurs in the connection of the Optical Fiber Cable between the camera and the HD Optical Multiplex Unit. Turn off the power of the camera and the HD Optical Multiplex Unit, check the connection of the Optical Fiber Cable and turn the powers on again. This message will also appear when the power of the camera is not turned on. Turn off the HD Optical Multiplex Unit, turn on the camera, then turn on the HD Optical Multiplex Unit again. |
| Option card error Please check option card | The message will appear when an interface board that cannot be used with the HD Optical Multiplex Unit is inserted into the card slot. Turn off the power of the HD Optical Multiplex Unit and remove the board. |
| CAUTION COOLING FAN STOPPED! | Turn off the power of the camera, and consult with your Sony dealer. |

Troubleshooting

Before bringing in your camera for service, check the following as a guide to troubleshoot the problem. If the problem cannot be corrected, consult with your Sony dealer.

| Symptom | Cause | Remedy |
|--|---|--|
| The power of the camera is not turned on. | The AC power adaptor is not connected to the DC IN 12V jack firmly. | Insert the power cord firmly as far as it will go. |
| | The AC power cord is not inserted firmly into the AC power adaptor or the AC outlet. | Insert the power cord firmly as far as it will go. |
| | The BRBK-H700 HD Optical Multiplex Card is inserted into the card slot. | Remove the card from the card slot. |
| | When using the far distance remote control system with the BRBK-H700 Optical Multiplex Card, CCFC-M100HG Optical Fiber Cable and BRU-H700 HD Optical Multiplex Unit, the Optical Fiber Cable is not properly connected or the HD Optical Multiplex Unit is not turned on. | Insert the Optical Fiber Cable firmly as far as it will go. Turn on the HD Optical Multiplex Unit, or plug in the power cord of the unit to an AC outlet firmly. |
| The camera cannot be turned on with the supplied Remote Commander. | IR-RECEIVE in the SYSTEM menu is set to OFF. | Use the RM-BR300 Remote Control Unit to open the menu and set IR-RECEIVE to ON. (page 35) |
| The picture is not displayed on the video monitor connected to the camera. | The video cable is not connected properly. | Check the connection between the camera and video monitor. |
| | The exposure is not set correctly on the camera. | Set the exposure correctly in the EXPOSURE menu. |
| Pan, tilt or zoom cannot be operated. | Any menu is displayed on the monitor screen. | Press the DATA SCREEN button on the supplied Remote Commander or the MENU button on the RM-BR300 Remote Control Unit to turn off the menu from the monitor screen. |
| | The panning or tilting range is limited. | Change the PAN-TILT LIMIT setting in the PAN TILT ZOOM menu (page 34). |
| The Remote Commander does not work. | The CAMERA SELECT button you pressed on the Remote Commander does not match the number set with the IR SELECT switch on the camera. | Press the CAMERA SELECT button corresponding to the IR SELECT switch setting on the camera (page 40). |
| The camera cannot be operated with the RM-BR300 Remote Control Unit. | The connection using the VISCA RS-422 connectors is not correctly made. | Check that the connection to the VISCA RS-422 connectors is correctly made, and the RS-422 cable is properly connected. |
| | The BOTTOM switch on the bottom of the camera is set to any other address than "0 (AUTO)." | Identify the address of the camera (page 19), then set the MODE selector on the rear of the Remote Control Unit to the same address (page 23). |
| | VISCA control setting is not correct. | Select the proper setting (RS-232C or RS-422) with the BOTTOM switch on the bottom of the camera (page 19) and the DIP switch on the Remote Control Unit (page 23). |
| | The communication baud rate setting of the camera and the RM-BR300 differ. | Select the same communication baud rate (9600 bps or 38,400 bps) with the BOTTOM switch on the bottom of the camera (page 19) and the DIP switch on the Remote Control Unit (page 23). |
| | The NC (No Connection) switch is set to ON. | Set camera address selector switch 4 of the BOTTOM switches on the bottom of the camera to OFF (page 19). |

| Symptom | Cause | Remedy |
|--|--|---|
| The VISCA control is not available with a computer connected to the camera. | The computer is not correctly connected to the camera. | <p>Make sure the connection between the computer and camera is made correctly.</p> <p>Check that the VISCA control setting (RS-232C or RS-422) and the baud rate setting (9600 bps or 38,400 bps) are properly made with the BOTTOM switch on the bottom of the camera (page 19) and the DIP switch on the Remote Control Unit (page 23).</p> <p>Try to connect the camera to the RM-BR300 Remote Control Unit to check that the camera works properly.</p> |
| The picture quality obtained from the camera connected to a computer differs from that from the camera connected to a video monitor. | Depending on your computer or video capture board, you may not be able to obtain the expected picture quality. | Consult with your computer manufacturer or dealer for details. |
| The camera cannot be operated at all. | — | Pull out the plug of the power cord from the AC outlet, then reinsert it into the AC outlet after a while. |

Menu Configuration

The menus of the camera are configured as described below.
The initial settings of each item are in bold.

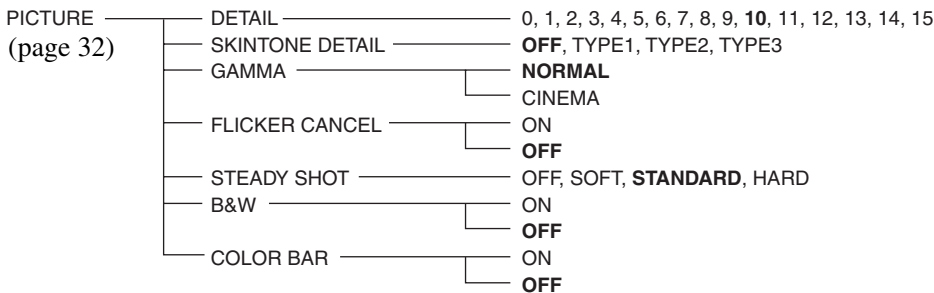
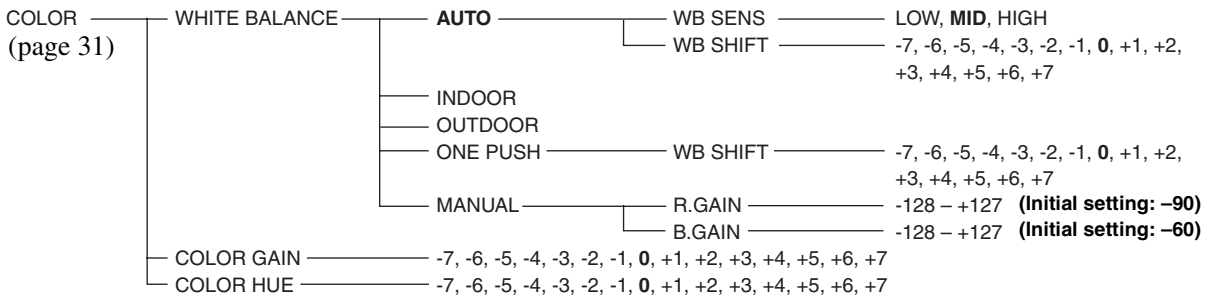
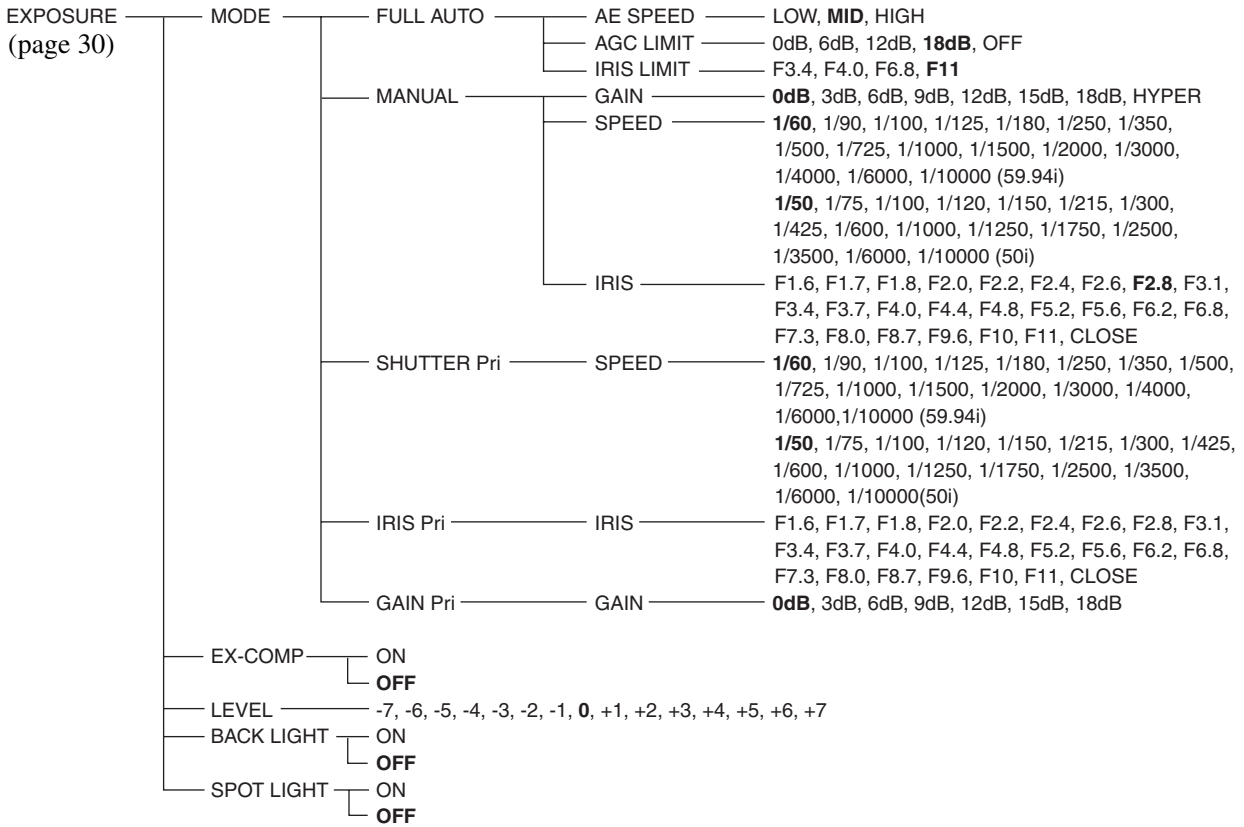

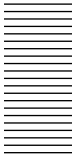
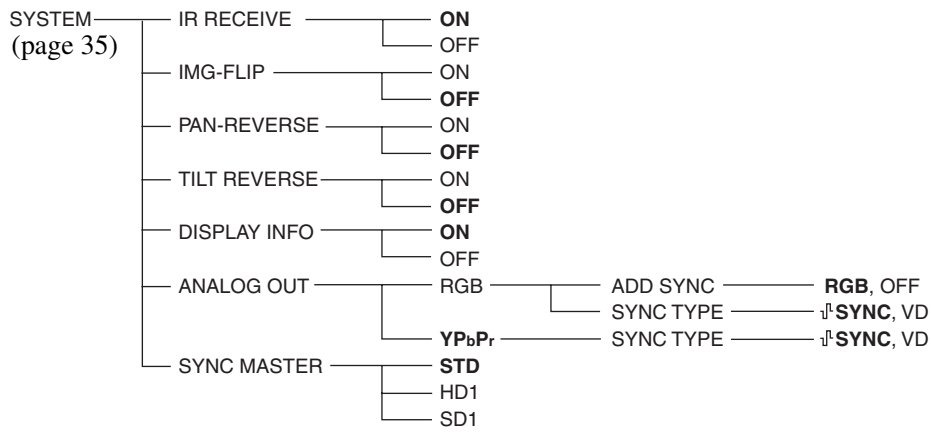
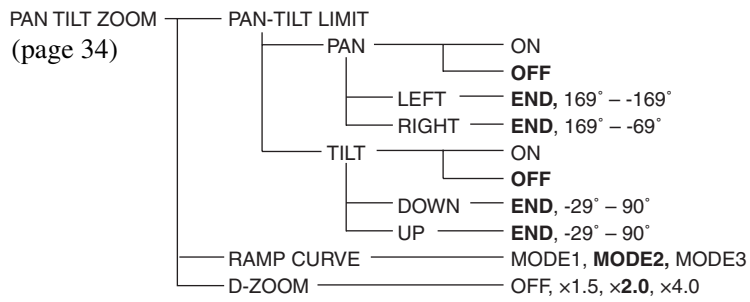

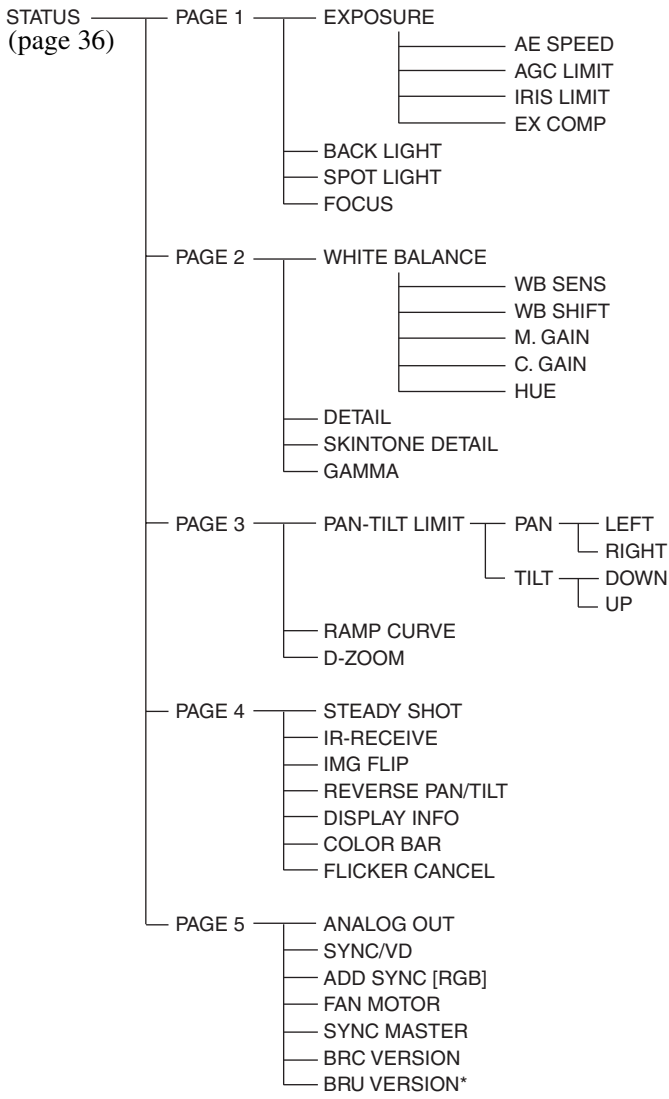

* Appears only when the BRU-H700 is connected.

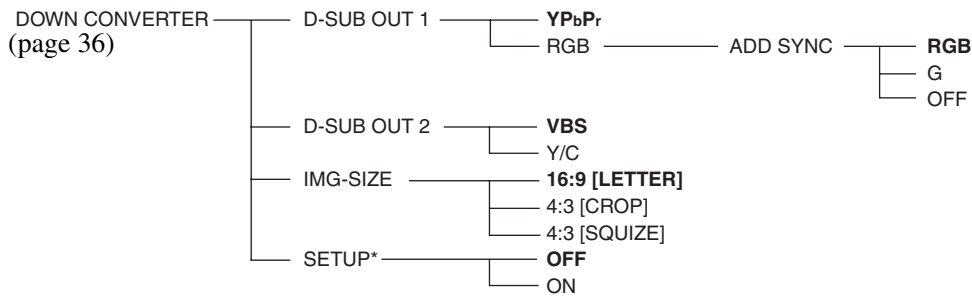

* Does not appear when an output signal is 50i format or RGB is selected in D-SUB OUT1.

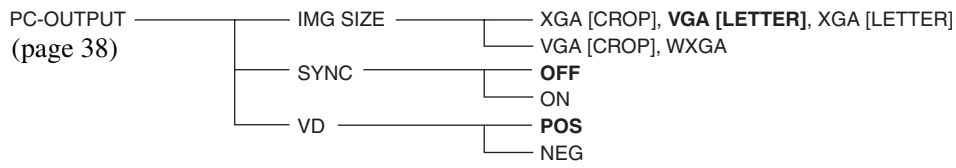
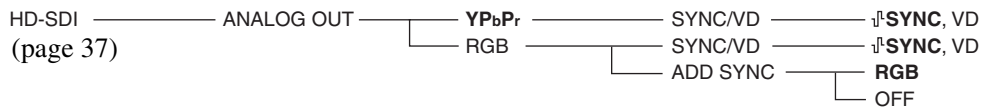

Presetting Items

The following setting items can be stored in the memory of the camera.

| Presetting item | Presetting position number | | | | | | | | | | | | | | | |
|------------------------------|----------------------------|---|---|---|---|---|---|---|---|----|----|----|----|----|----|----|
| | 1 | 2 | 3 | 4 | 5 | 6 | 7 | 8 | 9 | 10 | 11 | 12 | 13 | 14 | 15 | 16 |
| Pan/tilt position | ○ | ○ | ○ | ○ | ○ | ○ | ○ | ○ | ○ | ○ | ○ | ○ | ○ | ○ | ○ | ○ |
| Zoom position | ○ | ○ | ○ | ○ | ○ | ○ | ○ | ○ | ○ | ○ | ○ | ○ | ○ | ○ | ○ | ○ |
| Digital zoom on/off | ○ | ○ | ○ | ○ | ○ | ○ | ○ | ○ | ○ | ○ | ○ | ○ | ○ | ○ | ○ | ○ |
| Auto/manual focus mode | ○ | ○ | ○ | ○ | ○ | ○ | ○ | ○ | ○ | ○ | ○ | ○ | ○ | ○ | ○ | ○ |
| Focus position | ○ | ○ | ○ | ○ | ○ | ○ | ○ | ○ | ○ | ○ | ○ | ○ | ○ | ○ | ○ | ○ |
| White balance mode | ○ | ○ | ○ | ○ | ○ | ○ | ○ | ○ | ○ | ○ | ○ | ○ | ○ | ○ | ○ | ○ |
| Red/blue gain setting | ○ | ○ | ○ | ○ | ○ | ○ | ○ | ○ | ○ | ○ | ○ | ○ | ○ | ○ | ○ | ○ |
| Exposure mode | ○ | ○ | ○ | ○ | ○ | ○ | ○ | ○ | ○ | ○ | ○ | ○ | ○ | ○ | ○ | ○ |
| Shutter speed value | ○ | ○ | ○ | ○ | ○ | ○ | ○ | ○ | ○ | ○ | ○ | ○ | ○ | ○ | ○ | ○ |
| Iris value | ○ | ○ | ○ | ○ | ○ | ○ | ○ | ○ | ○ | ○ | ○ | ○ | ○ | ○ | ○ | ○ |
| Gain value | ○ | ○ | ○ | ○ | ○ | ○ | ○ | ○ | ○ | ○ | ○ | ○ | ○ | ○ | ○ | ○ |
| Exposure compensation on/off | ○ | ○ | ○ | ○ | ○ | ○ | ○ | ○ | ○ | ○ | ○ | ○ | ○ | ○ | ○ | ○ |
| Exposure compensation level | ○ | ○ | ○ | ○ | ○ | ○ | ○ | ○ | ○ | ○ | ○ | ○ | ○ | ○ | ○ | ○ |
| Back lighting on/off | ○ | ○ | ○ | ○ | ○ | ○ | ○ | ○ | ○ | ○ | ○ | ○ | ○ | ○ | ○ | ○ |
| Aperture level | ○ | ○ | ○ | ○ | ○ | ○ | ○ | ○ | ○ | ○ | ○ | ○ | ○ | ○ | ○ | ○ |

Presetting menu items

| Menu item | Presetting position number | | | | | | | | | | | | | | | |
|--------------------|----------------------------|---|---|---|---|---|---|---|---|----|----|----|----|----|----|----|
| | 1 | 2 | 3 | 4 | 5 | 6 | 7 | 8 | 9 | 10 | 11 | 12 | 13 | 14 | 15 | 16 |
| EXPOSURE MODE | ● | ○ | ○ | ○ | ○ | ○ | ○ | ○ | ○ | ○ | ○ | ○ | ○ | ○ | ○ | ○ |
| AE SPEED | ● | ○ | ○ | ○ | ○ | ○ | ○ | ○ | ○ | ○ | ○ | ○ | ○ | ○ | ○ | ○ |
| AGC LIMIT | ● | ○ | ○ | ○ | ○ | ○ | ○ | ○ | ○ | ○ | ○ | ○ | ○ | ○ | ○ | ○ |
| IRIS LIMIT | ● | ○ | ○ | ○ | ○ | ○ | ○ | ○ | ○ | ○ | ○ | ○ | ○ | ○ | ○ | ○ |
| MANUAL GAIN | ● | ○ | ○ | ○ | ○ | ○ | ○ | ○ | ○ | ○ | ○ | ○ | ○ | ○ | ○ | ○ |
| MANUAL SHUTTER | ● | ○ | ○ | ○ | ○ | ○ | ○ | ○ | ○ | ○ | ○ | ○ | ○ | ○ | ○ | ○ |
| MANUAL IRIS | ● | ○ | ○ | ○ | ○ | ○ | ○ | ○ | ○ | ○ | ○ | ○ | ○ | ○ | ○ | ○ |
| IRIS Pri VAL | ● | ○ | ○ | ○ | ○ | ○ | ○ | ○ | ○ | ○ | ○ | ○ | ○ | ○ | ○ | ○ |
| SHUTTER Pri VAL | ● | ○ | ○ | ○ | ○ | ○ | ○ | ○ | ○ | ○ | ○ | ○ | ○ | ○ | ○ | ○ |
| GAIN Pri VAL | ● | ○ | ○ | ○ | ○ | ○ | ○ | ○ | ○ | ○ | ○ | ○ | ○ | ○ | ○ | ○ |
| EX-COMP MODE | ● | ○ | ○ | ○ | ○ | ○ | ○ | ○ | ○ | ○ | ○ | ○ | ○ | ○ | ○ | ○ |
| EX-COMP VAL | ● | ○ | ○ | ○ | ○ | ○ | ○ | ○ | ○ | ○ | ○ | ○ | ○ | ○ | ○ | ○ |
| BACK LIGHT | ● | ○ | ○ | ○ | ○ | ○ | ○ | ○ | ○ | ○ | ○ | ○ | ○ | ○ | ○ | ○ |
| SPOT LIGHT | ● | ○ | ○ | ○ | ○ | ○ | ○ | ○ | ○ | ○ | ○ | ○ | ○ | ○ | ○ | ○ |
| WHITE BALANCE MODE | ● | ○ | ○ | ○ | ○ | ○ | ○ | ○ | ○ | ○ | ○ | ○ | ○ | ○ | ○ | ○ |
| WB SENS | ● | ○ | ○ | ○ | ○ | ○ | ○ | ○ | ○ | ○ | ○ | ○ | ○ | ○ | ○ | ○ |
| WB SHIFT | ● | ○ | ○ | ○ | ○ | ○ | ○ | ○ | ○ | ○ | ○ | ○ | ○ | ○ | ○ | ○ |
| MANUAL R.GAIN | ● | ○ | ○ | ○ | ○ | ○ | ○ | ○ | ○ | ○ | ○ | ○ | ○ | ○ | ○ | ○ |
| MANUAL B.GAIN | ● | ○ | ○ | ○ | ○ | ○ | ○ | ○ | ○ | ○ | ○ | ○ | ○ | ○ | ○ | ○ |
| COLOR GAIN | ● | ○ | ○ | ○ | ○ | ○ | ○ | ○ | ○ | ○ | ○ | ○ | ○ | ○ | ○ | ○ |
| COLOR HUE | ● | ○ | ○ | ○ | ○ | ○ | ○ | ○ | ○ | ○ | ○ | ○ | ○ | ○ | ○ | ○ |
| DETAIL | ● | ○ | ○ | ○ | ○ | ○ | ○ | ○ | ○ | ○ | ○ | ○ | ○ | ○ | ○ | ○ |
| SKINTONE DETAIL | ● | ○ | ○ | ○ | ○ | ○ | ○ | ○ | ○ | ○ | ○ | ○ | ○ | ○ | ○ | ○ |
| GAMMA | ● | ○ | ○ | ○ | ○ | ○ | ○ | ○ | ○ | ○ | ○ | ○ | ○ | ○ | ○ | ○ |
| FLICKER CANCEL | ● | ○ | ○ | ○ | ○ | ○ | ○ | ○ | ○ | ○ | ○ | ○ | ○ | ○ | ○ | ○ |

| Menu item | Presetting position number | | | | | | | | | | | | | | | |
|--|----------------------------|---|---|---|---|---|---|---|---|----|----|----|----|----|----|----|
| | 1 | 2 | 3 | 4 | 5 | 6 | 7 | 8 | 9 | 10 | 11 | 12 | 13 | 14 | 15 | 16 |
| STEADY SHOT | ● | ○ | ○ | ○ | ○ | ○ | ○ | ○ | ○ | ○ | ○ | ○ | ○ | ○ | ○ | ○ |
| B&W | ● | ○ | ○ | ○ | ○ | ○ | ○ | ○ | ○ | ○ | ○ | ○ | ○ | ○ | ○ | ○ |
| COLOR BAR | - | - | - | - | - | - | - | - | - | - | - | - | - | - | - | - |
| FOCUS MODE | ● | ○ | ○ | ○ | ○ | ○ | ○ | ○ | ○ | ○ | ○ | ○ | ○ | ○ | ○ | ○ |
| PAN LIMIT MODE | △ | - | - | - | - | - | - | - | - | - | - | - | - | - | - | - |
| TILT LIMIT MODE | △ | - | - | - | - | - | - | - | - | - | - | - | - | - | - | - |
| PAN LIMIT AREA | △ | - | - | - | - | - | - | - | - | - | - | - | - | - | - | - |
| TILT LIMIT AREA | △ | - | - | - | - | - | - | - | - | - | - | - | - | - | - | - |
| RAMP CURVE | △ | - | - | - | - | - | - | - | - | - | - | - | - | - | - | - |
| D-ZOOM | ● | - | - | - | - | - | - | - | - | - | - | - | - | - | - | - |
| IR-RECEIVE | △ | - | - | - | - | - | - | - | - | - | - | - | - | - | - | - |
| IMG-FLIP | △ | - | - | - | - | - | - | - | - | - | - | - | - | - | - | - |
| PAN REVERSE | △ | - | - | - | - | - | - | - | - | - | - | - | - | - | - | - |
| TILT REVERSE | △ | - | - | - | - | - | - | - | - | - | - | - | - | - | - | - |
| DISPLAY INFO | △ | - | - | - | - | - | - | - | - | - | - | - | - | - | - | - |
| ANALOG OUT | △ | - | - | - | - | - | - | - | - | - | - | - | - | - | - | - |
| ADD SYNC | △ | - | - | - | - | - | - | - | - | - | - | - | - | - | - | - |
| SYNC TYPE | △ | - | - | - | - | - | - | - | - | - | - | - | - | - | - | - |
| SYNC MASTER | △ | - | - | - | - | - | - | - | - | - | - | - | - | - | - | - |
| Menu items displayed only when the HFBK-SD1 is installed | | | | | | | | | | | | | | | | |
| D-SUB OUT 1 | △ | - | - | - | - | - | - | - | - | - | - | - | - | - | - | - |
| ADD SYNC | △ | - | - | - | - | - | - | - | - | - | - | - | - | - | - | - |
| D-SUB OUT 2 | △ | - | - | - | - | - | - | - | - | - | - | - | - | - | - | - |
| IMG SIZE | △ | - | - | - | - | - | - | - | - | - | - | - | - | - | - | - |
| SETUP (not available for 50i output signal) | △ | - | - | - | - | - | - | - | - | - | - | - | - | - | - | - |
| Menu items displayed only when the HFBK-HD1 is installed | | | | | | | | | | | | | | | | |
| ANALOG OUT | △ | - | - | - | - | - | - | - | - | - | - | - | - | - | - | - |
| SYNC MASTER | △ | - | - | - | - | - | - | - | - | - | - | - | - | - | - | - |
| SYNC/VD | △ | - | - | - | - | - | - | - | - | - | - | - | - | - | - | - |
| ADD SYNC | △ | - | - | - | - | - | - | - | - | - | - | - | - | - | - | - |
| Menu items displayed only when the HFBK-XG1 is installed | | | | | | | | | | | | | | | | |
| IMG SIZE | △ | - | - | - | - | - | - | - | - | - | - | - | - | - | - | - |
| SYNC | △ | - | - | - | - | - | - | - | - | - | - | - | - | - | - | - |
| VD | △ | - | - | - | - | - | - | - | - | - | - | - | - | - | - | - |
| Menu items displayed only when the HFBK-TS1 is installed | | | | | | | | | | | | | | | | |
| AUDIO DELAY | △ | - | - | - | - | - | - | - | - | - | - | - | - | - | - | - |

- : Setting items retained in memory when the power is turned off and on again. The camera starts with these settings.
- : Setting items retained in memory when the power is turned off and on again.
- △ : Setting items retained in memory only when the power is turned on.
- : Setting items cleared from the memory when the power is turned off and on.

Specifications

System

| | |
|-------------------------|---|
| Video signal | 1080/59.94i, 1080/50i (switched with the BOTTOM switch) |
| Synchronization | Internal/external synchronization, automatically switched |
| Image device | 1/3 type (6 mm), 3CCD Interline transfer type Total picture elements: Approx. 1,120,000 pixels Effective picture elements: Approx. 1,020,000 pixels |
| Lens | Carl Zeiss Vario-SonnarT* 12× (optical), 4× (digital) Filter diameter: 72 mm (Wide and tele conversion lenses cannot be attached.) f = 4.5 – 54 mm, F1.6 – F2.8 f = 32.5 mm – 390 mm (equivalent to the focal length of a 35-mm camera) |
| Minimum object distance | 800 mm (31 1/2 inches) (TELE end)/ 500 mm (19 3/4 inches) (WIDE end) |
| Minimum illumination | 6 lux (F1.6) with 50 IRE (WIDE end) |
| Shutter speed | 1/59.94 (1/50) to 1/10,000 sec. |
| Video S/N | 50 dB |
| Pan/tilt action | Horizontal: ±170 degrees Maximum panning speed: 60 degrees/sec. Minimum panning speed: 0.25 degrees/sec. Vertical: +90 degrees, -30 degrees Maximum tilting speed: 60 degrees/sec. Minimum tilting speed: 0.25 degrees/sec. |

Input/output connectors

| | |
|--------------|---|
| Video output | D-sub 15-pin RGB: 0.7Vp-p (no sync, at 75-ohm termination) 1Vp-p (±0.3V, tri-level sync, at 75-ohm termination) Component : Y: 1Vp-p (±0.3V, tri-level sync, at 75-ohm termination) Pb/Pr: ±350 mVp-p, 75-ohm terminated HD/VD Sync: 1Vp-p, 75-ohm terminated |
|--------------|---|

Tri-level Sync: ±300 mVp-p, 75-ohm terminated

| | |
|-----------------------|---|
| External sync input | EXT SYNC IN: BNC type |
| Control input/output | VISCA RS-232C IN: Mini DIN 8-pin type VISCA RS-232C OUT: Mini DIN 8-pin type VISCA RS-422: 9-pin type |
| Control signal format | 9600 bps/38400 bps Data: 8 bit Stop bit: 1 |
| Power connector | JEITA type4 (DC IN 12V) |

General

| | |
|-----------------------|--|
| Input voltage | 12 V DC (10.8 to 13.2 V DC) |
| Current consumption | 2.0 A max. (at 12 V DC), 24 W without optional interface board |
| Operating temperature | 0°C to 40°C (32°F to 104°F) |
| Storage temperature | -20°C to +60°C (-4°F to 140°F) |
| Dimensions | Video camera: ø207 × 315.8 mm (ø8 1/4 × 12 1/2 inches) (diameter/h) (excluding protruding parts) Remote Commander: 56 × 26 × 210 mm (2 1/4 × 1 1/16 × 8 3/8 inches) (w/h/d) |
| Mass | Video camera: Approx. 4.5 kg (9 lb 15 oz) Remote Commander: 110 g (3.9 oz) |
| Installation angle | Less than ±15 degrees to the horizontal surface |

Supplied accessories

| |
|--|
| AC power adaptor MPA-AC1 (Sony) (100 V AC, 50/60 Hz) (1) |
| AC power cord (1) |
| Remote Commander (1) |
| Ceiling bracket (A) (1) |
| Ceiling bracket (B) (1) |
| Wire rope (1) |
| Screws (⊕M3 × 8) (7) |
| Screw (⊕M4 × 8) (1) |
| RS-422 connector plug (1) |
| Operating Instructions (1) |

Design and specifications are subject to change without notice.

Dimensions

BRC-H700 Video Camera

Top

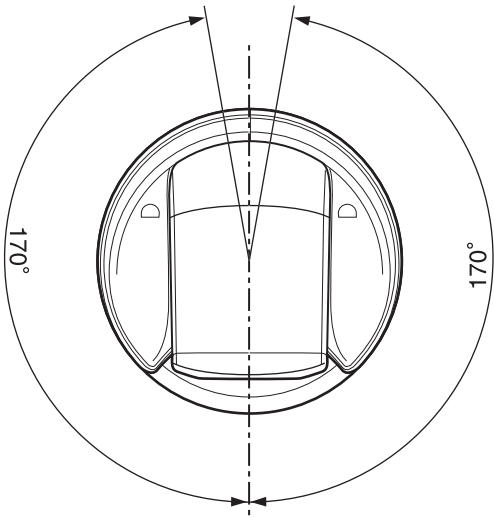

Front

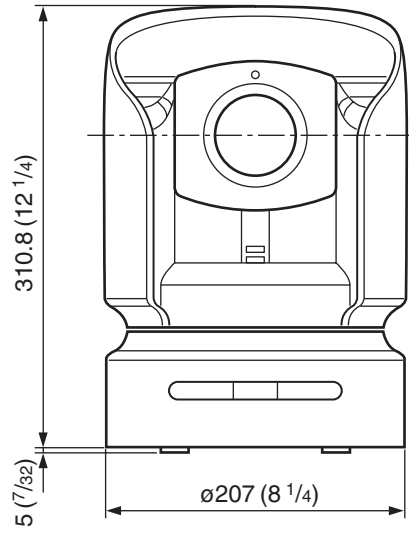

Side

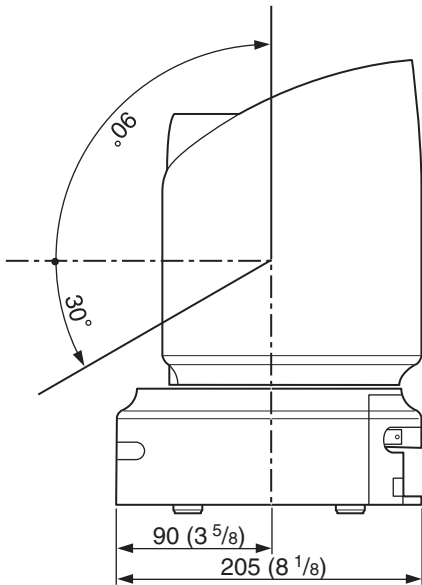

Bottom

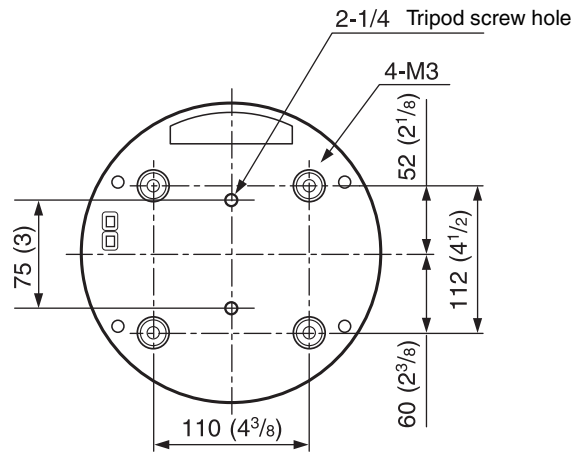

Ceiling Bracket (B)

Top

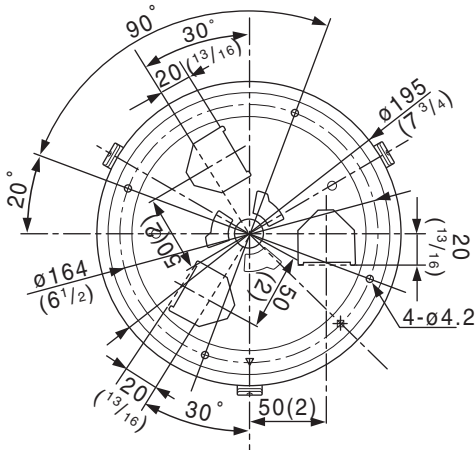

Side

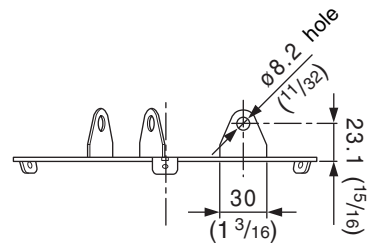

Unit: mm (inches)

RM-BR300 Remote Control Unit

Top

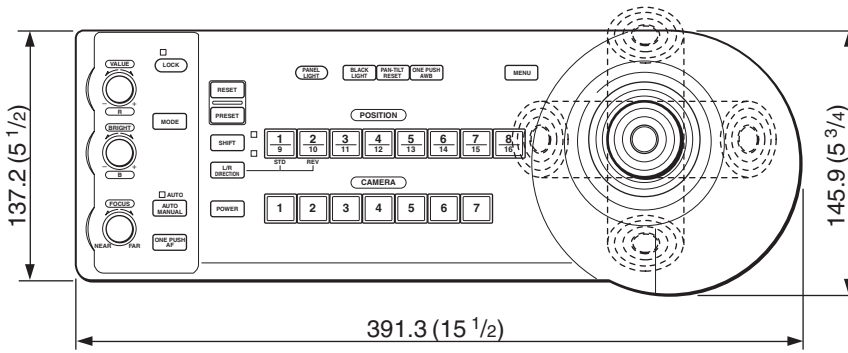

Side

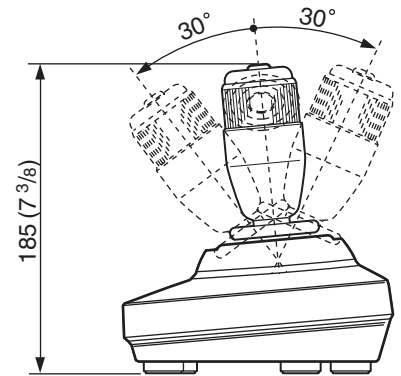

Front

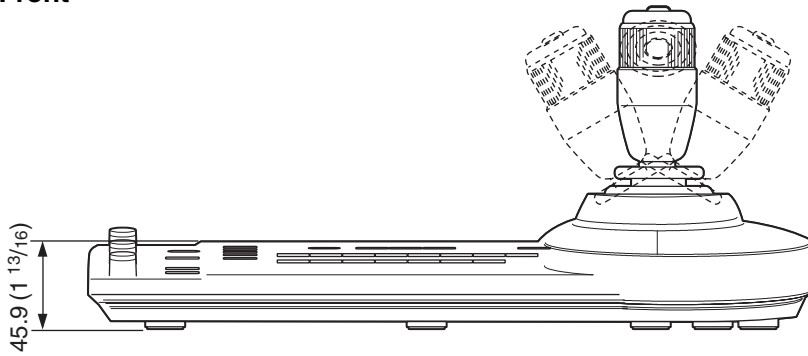

Bottom

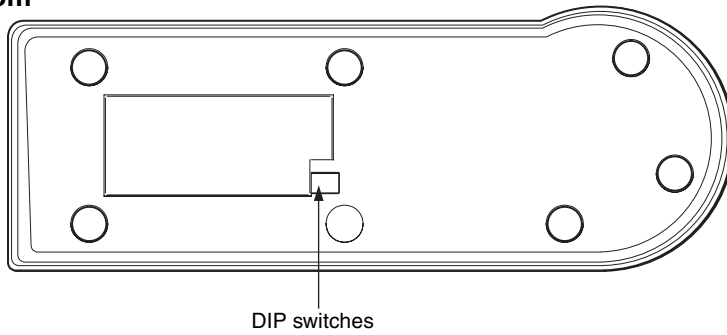

Unit: mm (inches)

BRU-H700 HD Optical Multiplex Unit

Top

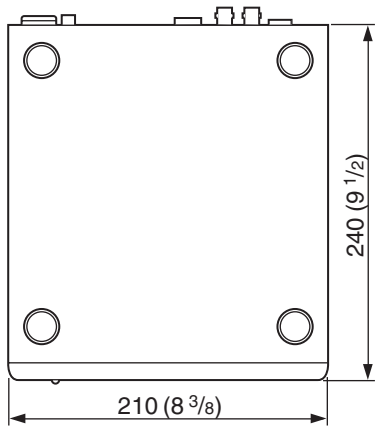

Side

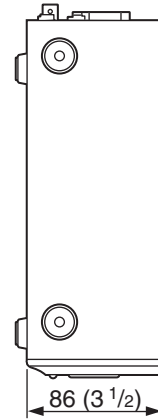

Front

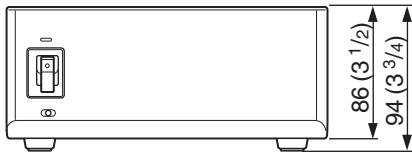

Unit: mm (inches)

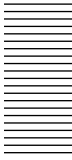

Appendix

Pin Assignments

BRC-H700 Video Camera

VISCA RS-422 connector (connector plug 9-pin)

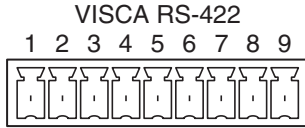

| Pin No. | Function |
|---------|-----------|
| 1 | RXD OUT - |
| 2 | RXD OUT+ |
| 3 | TXD OUT - |
| 4 | TXD OUT+ |
| 5 | GND |
| 6 | RXD IN - |
| 7 | RXD IN+ |
| 8 | TXD IN - |
| 9 | TXD IN+ |

VISCA RS-232C IN connector (mini-DIN 8-pin, female)

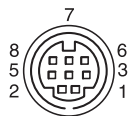

IN VISCA RS-232C

| Pin No. | Function |
|---------|---------------|
| 1 | DTR IN |
| 2 | DSR IN |
| 3 | TXD IN |
| 4 | GND |
| 5 | RXD IN |
| 6 | GND |
| 7 | SIRCS OUT * |
| 8 | No Connection |

* The SIRCS OUT function is selectable with the BOTTOM switch on the bottom of the camera.

VISCA RS-232C OUT connector (mini DIN 8-pin, female)

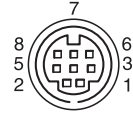

VISCA RS-232C OUT

| Pin No. | Function |
|---------|---------------|
| 1 | DTR OUT |
| 2 | DSR OUT |
| 3 | TXD OUT |
| 4 | GND |
| 5 | RXD OUT |
| 6 | GND |
| 7 | No Connection |
| 8 | No Connection |

Analog RGB/COMPONENT (D-sub 15-pin)

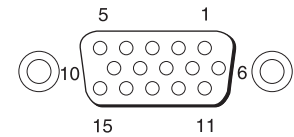

RGB/COMPONENT

| Pin No. | Function | | | |
|---------|----------------------------|------------------------------------|--------------------------|------------------------|
| | At YPbPr COMPONENT setting | At YPbPr COMPONENT setting (at VD) | At RGB setting (at SYNC) | At RGB setting (at VD) |
| 1 | Pr-OUT | Pr-OUT | R-OUT | R-OUT |
| 2 | Y-OUT | Y-OUT | G-OUT | G-OUT |
| 3 | Pb-OUT | Pb-OUT | B-OUT | B-OUT |
| 4 | GND | GND | GND | GND |
| 5 | GND | GND | GND | GND |
| 6 | GND | GND | GND | GND |
| 7 | GND | GND | GND | GND |
| 8 | GND | GND | GND | GND |
| 9 | NC | NC | NC | NC |
| 10 | GND | GND | GND | GND |
| 11 | GND | GND | GND | GND |
| 12 | NC | NC | NC | NC |
| 13 | HD-OUT | HD-OUT | HD-OUT | HD-OUT |
| 14 | Tri-level SYNC-OUT | Bi-level VD-OUT | Tri-level SYNC-OUT | Bi-level VD-OUT |
| 15 | NC | NC | NC | NC |

RM-BR300 Remote Control Unit (optional)

VISCA RS-232C output connector (mini DIN 8-pin, female)

RS-232C

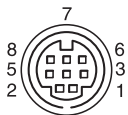

| Pin No. | Function |
|---------|---------------|
| 1 | No Connection |
| 2 | No Connection |
| 3 | TXD IN |
| 4 | GND |
| 5 | RXD IN |
| 6 | GND |
| 7 | No Connection |
| 8 | No Connection |

VISCA RS-422 connector (connector plug, 9-pin)

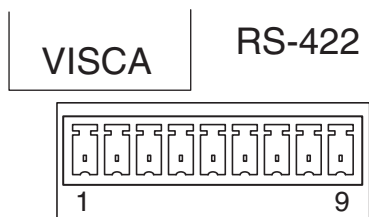

| Pin No. | Function |
|---------|---------------|
| 1 | No Connection |
| 2 | No Connection |
| 3 | No Connection |
| 4 | No Connection |
| 5 | GND |
| 6 | RXD IN - |
| 7 | RXD IN+ |
| 8 | TXD IN - |
| 9 | TXD IN+ |

TALLY/CONTACT connector (connector plug, 9-pin)

TALLY/CONTACT

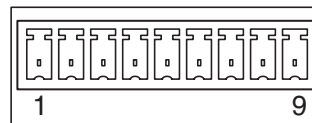

| Pin No. | Function |
|---------|----------|
| 1 | CAMERA1 |
| 2 | CAMERA2 |
| 3 | CAMERA3 |
| 4 | CAMERA4 |
| 5 | CAMERA5 |
| 6 | CAMERA6 |
| 7 | CAMERA7 |
| 8 | GND |
| 9 | GND |

BRU-H700 HD Optical Multiplex Unit
(optional)

VISCA RS-232C IN connector (mini DIN 8-pin, female)

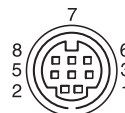

IN VISCA RS-232C

| Pin No. | Function |
|---------|---------------|
| 1 | DTR IN |
| 2 | DSR IN |
| 3 | TXD IN |
| 4 | GND |
| 5 | RXD IN |
| 6 | GND |
| 7 | No Connection |
| 8 | No Connection |

VISCA RS-232C OUT connector (mini DIN 8-pin, female)

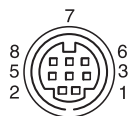

VISCA RS-232C OUT

| Pin No. | Function |
|---------|---------------|
| 1 | DTR OUT |
| 2 | DSR OUT |
| 3 | TXD OUT |
| 4 | GND |
| 5 | RXD OUT |
| 6 | GND |
| 7 | No Connection |
| 8 | No Connection |

VISCA RS-422 connector (connector plug, 9-pin)

VISCA RS-422

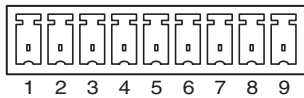

| Pin No. | Function |
|---------|-----------|
| 1 | RXD OUT - |
| 2 | RXD OUT+ |
| 3 | TXD OUT - |
| 4 | TXD OUT+ |
| 5 | GND |
| 6 | RXD IN - |
| 7 | RXD IN+ |
| 8 | TXD IN - |
| 9 | TXD IN+ |

Analog RGB/COMPONENT (D-sub 15-pin)

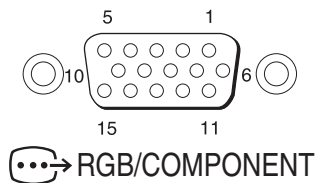

| Pin No. | Function | | | |
|---------|----------------------------|------------------------------------|--|------------------------|
| | At YPbPr COMPONENT setting | At YPbPr COMPONENT setting (at VD) | At RGB setting (at $\frac{1}{2}$ SYNC) | At RGB setting (at VD) |
| 1 | Pr-OUT | Pr-OUT | R-OUT | R-OUT |
| 2 | Y-OUT | Y-OUT | G-OUT | G-OUT |
| 3 | Pb-OUT | Pb-OUT | B-OUT | B-OUT |
| 4 | GND | GND | GND | GND |
| 5 | GND | GND | GND | GND |
| 6 | GND | GND | GND | GND |
| 7 | GND | GND | GND | GND |
| 8 | GND | GND | GND | GND |
| 9 | NC | NC | NC | NC |
| 10 | GND | GND | GND | GND |
| 11 | GND | GND | GND | GND |
| 12 | NC | NC | NC | NC |
| 13 | HD-OUT | HD-OUT | HD-OUT | HD-OUT |
| 14 | Tri-level SYNC-OUT | Bi-level VD-OUT | Tri-level SYNC-OUT | Bi-level VD-OUT |
| 15 | NC | NC | NC | NC |

Wiring Diagram of VISCA RS-422 Connection

Third to Seventh BRC-H700 or BRU-H700

VISCA RS-422 connector

| | |
|---|-----------|
| 1 | RXD OUT - |
| 2 | RXD OUT + |
| 3 | TXD OUT - |
| 4 | TXD OUT + |
| 5 | GND |
| 6 | RXD IN - |
| 7 | RXD IN + |
| 8 | TXD IN - |
| 9 | TXD IN + |

Second BRC-H700 or BRU-H700

VISCA RS-422 connector

| | |
|---|-----------|
| 1 | RXD OUT - |
| 2 | RXD OUT + |
| 3 | TXD OUT - |
| 4 | TXD OUT + |
| 5 | GND |
| 6 | RXD IN - |
| 7 | RXD IN + |
| 8 | TXD IN - |
| 9 | TXD IN + |

First BRC-H700 camera or BRU-H700 HD Optical Multiplex Unit

VISCA RS-422 connector

| | |
|---|-----------|
| 1 | RXD OUT - |
| 2 | RXD OUT + |
| 3 | TXD OUT - |
| 4 | TXD OUT + |
| 5 | GND |
| 6 | RXD IN - |
| 7 | RXD IN + |
| 8 | TXD IN - |
| 9 | TXD IN + |

RM-BR300 Remote Control Unit

VISCA RS-422 connector

| | |
|---|----------|
| 1 | NC |
| 2 | NC |
| 3 | NC |
| 4 | NC |
| 5 | GND |
| 6 | RXD IN - |
| 7 | RXD IN + |
| 8 | TXD IN - |
| 9 | TXD IN + |

NC = No Connection

