

VADDIO™ POWERVIEW™ HD-22 QDVI AND POWERVIEW HD-30 QDVI CAMERA SYSTEMS

PowerVIEW Series High Definition PTZ Cameras featuring the Quick-Connect™ DVI/HDMI-SR Interface

PowerVIEW HD-22 QDVI - High Definition PTZ Camera System (22X Optical Zoom)

Model Number 999-6966-000 (North America)

Model Number 999-6966-001 (International)

PowerVIEW HD-30 QDVI - High Definition PTZ Camera System (30X Optical Zoom)

Model Number 999-6976-000 (North America)

Model Number 999-6976-001 (International)

PowerVIEW 22/30 with CONCEAL Mount



Quick-Connect DVI/HDMI SR Interface



Inside Front Cover - Mostly Blank



TABLE OF CONTENTS

Overview 4

Unpacking 5

 Camera Front View with Feature Call-outs 6

 Image: PowerVIEW HD-22/30 QDVI Camera System 6

 Rear Panel Connections with Feature Call-outs 7

 Image: PowerVIEW HD-22/30 QDVI Camera System 7

First Time Set-up with the PowerVIEW HD-22 or HD-30 QDVI System 7

 Image: PowerVIEW HD-22/30 Rear Panel Connections 8

 Drawing: Dip Switch and Resolution Label on the Bottom of the HD-22/30 8

Quick-Connect DVI/HDMI SR Interface 9

 Image: Rear Panel Connectors and Features 9

 Image: Quick-Connect DVI/HDMI SR Interface Front Panel 9

Installation Procedures 10

 Before Installing: 10

 Installation Basics: 10

 General Installation Instructions for the CONCEAL Wall Mounting System: 10

 Image: Basic Connectivity Example of the HD-22 or HD-30 12

Daisy Chain Configurations 13

Compliance and CE Declaration of Conformity - PowerVIEW HD-22 and HD30 14

Compliance and CE Declaration of Conformity - Quick-Connect DVI/HDMI SR Interface 15

Warranty Information 16

General Specifications 17

Appendix 1: Pin-Outs for the HD-22/30 Camera 18

 Drawing: PowerVIEW HD-22/30 Camera Dimensions 19

Communication Specification 20

 HD-22/30 Command List (1/2) 20

 HD-22/30 Command List (2/2) 21

 HD-22/30 Inquiry List (1/1) 22

OVERVIEW

The remarkable Vaddio PowerVIEW HD-22 and HD-30 high definition PTZ cameras are available in the super-versatile Vaddio PowerVIEW QDVI system packages. The PowerVIEW HD-22 QDVI and the PowerVIEW HD-30 QDVI feature 22X and 30X power zoom optics respectively. These cameras use a CMOS, 1/2.8-Type, progressive scan image sensors, which provide for better light sensitivity, increased noise reduction and lower power consumption than cameras with either CCD or CMOS image sensors. This advanced MOS image sensor captures realistic textures, vivid colors and delicate gradations that are comparable to 3-chip camera performance.

Both the HD-22 and the HD-30 provide matchless low-light capabilities with a minimum illumination rating of an amazing 0.4 lux (color) and 0.04 lux (B/W). Equipped with a 2.2 megapixel CMOS sensor, the cameras deliver native FULL HD 1080p/60 high definition video resolution and superior color reproduction for use in any professional A/V presentation, videoconferencing, House of Worship, education, live event and industrial applications.



Image: PowerVIEW HD-22 or HD-30 PTZ Camera (above) and the Quick-Connect DVI/HDMI SR Interface (below)



The HD-22 has a powerful 22X multi-element glass zoom lens (f=4.3mm to 94.6mm) and works exceptionally well in large rooms. However, the premium optics also provides a super-wide horizontal field of view of 65.2°, which works very well in small room video applications. The HD-30, as one could probably guess, has a robust 30X optical power zoom lens that enables the capture of brilliant and detailed video images even in the largest rooms.

The cameras output multi-format HD video in both analog component (YPbPr), HDMI and differential formats in HD resolutions of 1080p/59.94, 1080p/50 1080p/29.97 1080p/25, 1080i/59.94, 1080i/50, 720p/59.94, 720p/50 and progressive SD resolutions of 480p/59.97 and 576p/50. Both cameras are offered with DVI/HDMI SR packages with the Quick-Connect DVI/HDMI SR Interface that uses HSDS™ for distribution of video, power and control over Cat-5 cable up to 100' (30.48m) and are capable of providing analog component YPbPr and HDMI concurrently from the Quick-Connect interface. The PowerVIEW HD-22 QDVI and HD-30 QDVI camera systems represent an exceptional value and are superb performers for even the most demanding video applications.

Intended Use:

Before operating the device, please read the entire manual thoroughly. The system was designed, built and tested for use indoors with the power supply provided. The use of a power supply other than the one provided or outdoor operation hasn't been tested and may damage the device and/or create an unsafe operating condition.

Important Safeguards:

Read and understand all instructions before using. Do not operate any device if it has been dropped or damaged. In this case, a Vaddio technician must examine the product before operating. To reduce the risk of electric shock, do not immerse in water or other liquids and avoid extremely humid conditions.



Use only the power supply provided with the system. Use of any unauthorized power supply will void any and all warranties.



Please do not use "pass-thru" type RJ-45 connectors. These pass-thru type connectors do not work well for professional installations and can be the cause of intermittent connections which can result in the RS-232 control line failing and locking up, and/or compromising the HSDS (high speed differential) signals. For best results please use standard RJ-45 connectors and test all cables for proper pin-outs prior to use and connection to Vaddio product.

Save These Instructions:

The information contained in this manual will help you install and operate your product. If these instructions are misplaced, Vaddio keeps copies of Specifications, Installation and User Guides and most pertinent product drawings for the Vaddio product line on the Vaddio website. These documents can be downloaded from www.vaddio.com free of charge.

UNPACKING

Carefully remove the product and all of the included parts from the packaging. Identify the following parts for each camera:

PowerVIEW HD-22 QDVI Camera System (North America):

Part Number: 999-6966-000

- One (1) PowerVIEW HD-22 HD PTZ Camera (998-6960-000)
- One (1) Vaddio IR Remote Commander
- One (1) Quick-Connect DVI/HDMI-SR Interface
- One (1) 3-Position Phoenix-type Connector for IR Forwarding
- One (1) 24 VDC, 2.0 A Power Supply with Power Cord for North America
- One (1) CONCEAL Wall Mount with Mounting Hardware
- One (1) EZCamera™ Control Adapter (RJ-45-F to DB-9-F)
- Quick Start Guide

Full Manuals are downloaded from support.vaddio.com

PowerVIEW HD-22 QDVI Camera System (International):

Part Number: 999-6966-001

- One (1) PowerVIEW HD-22 HD PTZ Camera (998-6960-000)
- One (1) Vaddio IR Remote Commander
- One (1) Quick-Connect DVI/HDMI SR Interface
- One (1) 3-Position Phoenix-type Connector for IR Forwarding
- One (1) 24 VDC, 2.0 A Power Supply
- One (1) Euro Power Cable
- One (1) UK Power Cable
- One (1) CONCEAL Wall Mount with Mounting Hardware
- One (1) EZCamera Control Adapter (RJ-45 to DB-9)
- Quick Start Guide

Full Manuals are downloaded from support.vaddio.com

PowerVIEW HD-30 QDVI Camera System (North America):

Part Number: 999-6976-000

- One (1) PowerVIEW HD-30 HD PTZ Camera (998-6970-000)
- One (1) Vaddio IR Remote Commander
- One (1) Quick-Connect DVI/HDMI SR Interface
- One (1) 3-Position Phoenix-type Connector for IR Forwarding
- One (1) 24 VDC, 2.0 A Power Supply with Power Cord for North America
- One (1) CONCEAL Wall Mount with Mounting Hardware
- One (1) EZCamera Control Adapter (RJ-45-F to DB-9-F)
- Quick Start Guide

Full Manuals are downloaded from support.vaddio.com

PowerVIEW HD-30 QDVI Camera System (International):

Part Number: 999-6976-001

- One (1) PowerVIEW HD-30 HD PTZ Camera (998-6970-000)
- One (1) Vaddio IR Remote Commander
- One (1) Quick-Connect SR Interface
- One (1) 3-Position Phoenix-type Connector for IR Forwarding
- One (1) 24 VDC, 2.0 A Power Supply
- One (1) Euro Power Cable
- One (1) UK Power Cable
- One (1) CONCEAL Wall Mount with Mounting Hardware
- One (1) EZCamera Control Adapter (RJ-45 to DB-9)
- Quick Start Guide

Full Manuals are downloaded from support.vaddio.com



CONCEAL Mount includes:

- Metal Bracket (black)
- Bottom Cover
- Rear Connector/Cable Cover
- Mounting Hardware

Camera Front View with Feature Call-outs

Image: PowerVIEW HD-22/30 QDVI Camera System



1) Camera and Zoom Lens:

The 22X (HD-22) or 30X (HD-30) optical zoom lens is built around a (1/2.8 Type) high-speed MOS image sensor with a total of 2.2 megapixels for precise HD video image acquisition.

2) Red Tally Light:

A red tally light is illuminated when the camera receives a command from an external controller.

3) IR Sensors:

IR sensors are built into the front of the HD-22 and HD-30 to receive IR signals from the IR remote control supplied with the camera.

4) Blue Power Light:

A Vaddio blue power light is illuminated when the camera is turned on. This LED will blink when the camera receives IR signals from the Vaddio IR Remote Commander.

Rear Panel Connections with Feature Call-outs
Image: PowerVIEW HD-22/30 QDVI Camera System



5) RS-232 IN & IR Out:

The RS-232 port accepts modified VISCA protocol for camera control and transmits IR signaling received by the IR receivers, which can be relayed to third party equipment (IR Forwarding) through the Quick-Connect DVI/HDMI-SR Interface.

6) Dip Switch Settings:

Settings for IR remote, baud rate and image flip can be configured on these switches. See the Switch Settings page for additional information.

7) HD Video Select:

A rotary switch allows the user to choose the component HD output video resolution and format. See the Switch Settings page for additional information.

- **HD Resolution Note:** When changing the resolution of the camera, the camera may need to be power-cycled after the change. Pretty much every switcher will have to be reset or rebooted as well.

8) 12 VDC Input:

Power input for the standard 12 VDC, 3.0 Amp power supply for the HD-22 and HD-30. The 12 VDC power supply is only used with the standalone cameras, but not with the QDVI systems).

9) HDMI Output:

The HDMI output feeds out HD digital video only (no copy protect or device communication is required). The HDMI output is optimized for high definition video signals.

10) YPbPr Output:

Component HD video (YPbPr) is output through the DE-15 connector. YPbPr and HDMI signals have simultaneous output. Limited SD (YPbPr) resolutions are supported.

11) EZ Power HD Video Port:

This RJ-45 connector is used with the Quick-Connect SR type interfaces to supply power and return HSDS (differential) video from the camera. Please mark and test cables for voltage prior to connection.

12) Slot for Optional Cards:

The EZIM CCU slot card for the CCU can be plugged into the PowerVIEW HD-22 HD camera.

FIRST TIME SET-UP WITH THE POWERVIEW HD-22 OR HD-30 QDVI SYSTEM

The PowerVIEW HD-22 and HD-30 cameras in the QDVI Kit were designed to be very easy to use and operate. There is documentation at the back of this manual for pin-outs of the connectors.

Step 1: Using the HD VIDEO SELECT rotary switch and CAMERA SETTINGS DIP switches on the back of the camera, set up the camera's output resolution and functional preferences. There is a label on the bottom of the camera that identifies the choices.

Important Dip Switch Note: Setting all dip switches down and power cycling the camera will load the factory default camera settings. For the first time set-up, loading the defaults may be a good idea.

Image: PowerVIEW HD-22/30 Rear Panel Connections

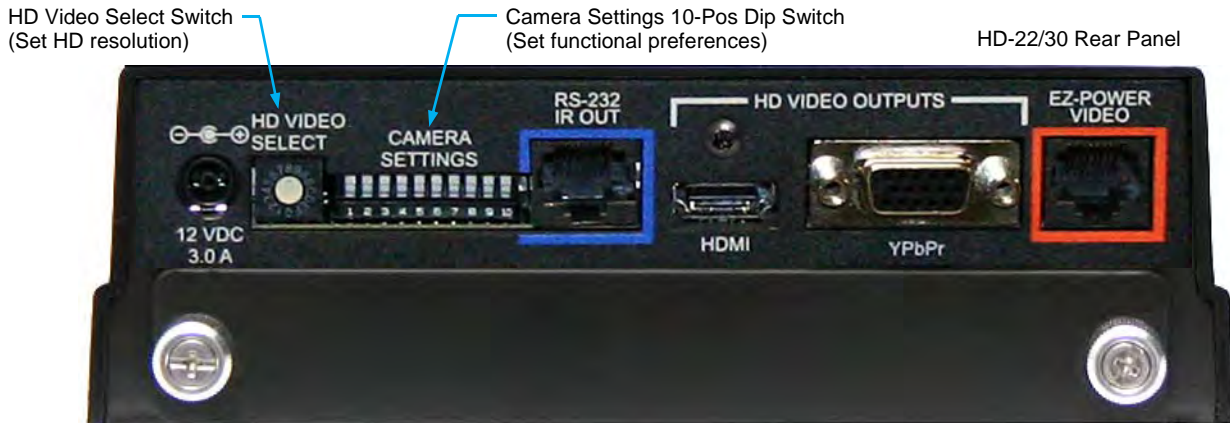

Drawing: Dip Switch and Resolution Label on the Bottom of the HD-22/30

② DIP SWITCH SETTINGS

IR 1 1 & 2 UP	IR OUT OFF	9600 bps	5 OFF	6 OFF	HDMI COLOR YCbCr	IMAGE FLIP OFF	9 OFF	10 OFF
<input type="checkbox"/>	<input type="checkbox"/>	<input type="checkbox"/>	<input type="checkbox"/>	<input type="checkbox"/>	<input type="checkbox"/>	<input type="checkbox"/>	<input type="checkbox"/>	<input type="checkbox"/>
IR 2 ON	IR 3 ON	ON	38400 bps	—	—	sRGB	ON	—
1	2	3	4	5	6	7	8	9

① VIDEO RESOLUTION SELECT

0	720p/59.94	8	576p/50
1	1080i/59.94	9	—
2	1080p/59.94	A	—
3	—	B	—
4	720p/50	C	—
5	1080i/50	D	—
6	1080p/50	E	1080p/29.97
7	480p/59.94	F	1080p/25

⑦ All Down with Power Cycle for Defaults

Setting the Switches:

- 1) Set the desired and available HD output resolution for the camera with the Rotary Switch.
- 2) Set the IR control frequency of the camera if it is to respond to the IR remote control.
- 3) If using the IR forwarding features with a 3rd party codec remote, set the IR OUT switch to ON (SW3).
- 4) Set the Baud Rate dip switch (SW4) to 9600bps for most applications. Default is 9600 bps for Cat-5 systems.
- 5) To set the HDMI or DVI color space, use dip switch 7 (SW7).
- 6) If inverting the camera, turn the IMAGE FLIP ON (SW8).
- 7) All dip switches DOWN with a power cycle loads the default camera settings. Return dips to desired operating position.

Dip Switch Settings Explained:

- **IR 1, 2 and 3 (SW 1 & 2):** A single IR remote has the capability of operating up to three different PTZ cameras in a room. Use these selector dip switches and the selector buttons at the top of the IR remote to select the frequency.
- **IR OUT on/off (SW3):** The IR output is sent out on the RS-232 RJ-45 jack on the back of the camera. Turning on the IR output will allow IR signals to be transmitted over the Cat-5 cable to the head end from 3rd party remotes. When using RS-232 control or Vaddio CCU controllers (also via RS-232), turn the IR OUT to OFF (up).
- **Baud Rate (SW4):** The options for baud rate are either 9600 or 38,400 bps. The 9600 bps works best with Cat-5.
- **HDMI Color or sRGB Color space (SW7):** Default is YCbCr. Use sRGB color space with older DVI-D 1.0 equipment or monitors only. The YCbCr color space is used for HDMI digital video.
- **Image Flip (SW8):** To invert the HD-20, turn the IMAGE FLIP ON (switch down).
- **Dip Switches 5, 6, 9 and 10:** Not used for operation, please leave these dip switches up or in the OFF position.

QUICK-CONNECT DVI/HDMI SR INTERFACE

Image: Rear Panel Connectors and Features

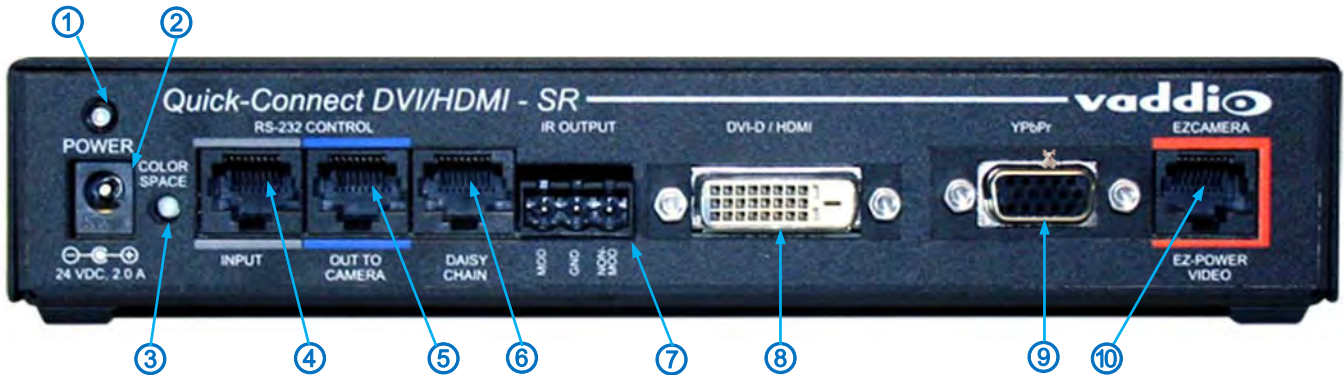

- 1) **Power Light:** Blue LED Power Indicator
- 2) **24 VDC Power Port:** Coax Power Connector, 5.5mm OD x 2.5mm ID, Positive Center.
- 3) **Recessed Color Space Conversion Switch:** Toggles between HDMI YCbCr and sRGB (RGBHV) color space. Change the color space to accommodate either HDMI or DVI-D monitors.
- 4) **RS-232 INPUT (Color Coded Grey):** For use with joystick controller, codec or control system.
- 5) **RS-232 OUT TO CAMERA (Color Coded Blue):** RS-232 Control to & from Camera and IR signals returned from the camera.
- 6) **Daisy Chain Control Port:** Daisy Chain Control Emulation (DCCE) output to next Quick-Connect DVI/HDMI SR Interface (does not function with the AutoTrak System).
- 7) **IR Output Port:** Non-modulated (for hard connections) and Modulated for use with IR emitters.
- 8) **DVI-D Output:** High Definition Multimedia Interface (HDMI) Transmitter, HDMI (v 1.3 with deep color) and DVI v 1.0 Compliant - use Recessed Color Space Conversion Switch ③ to toggle between HDMI YCbCr and DVI-D sRGB color spaces to suit your monitors
- 9) **YPbPr Output:** Analog Component Video Output on DE-15F (HD-15F) Connector, Resolutions up to 1080p/60 with monitor support.
- 10) **EZ-POWER VIDEO Port (Color Coded Orange):** Supplies power to camera and returns HD video from the camera via Cat-5e. Maximum distance on the Cat-5e cable is 100' (30.5 m).

Image: Quick-Connect DVI/HDMI SR Interface Front Panel

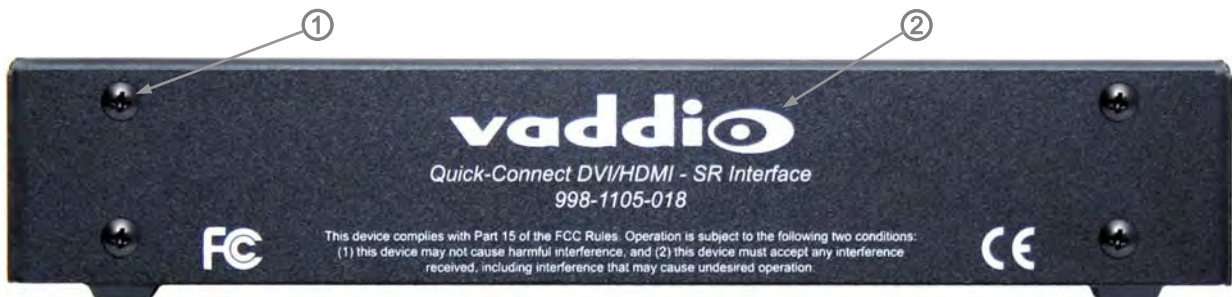

- 1) **Front Panel Screws (x 4):**
Remove and reuse these screws when mounting to the 998-6000-003 Optional 1-RU Rack Panel for Two (2) ½-Rack sized enclosures. Optional panel holds two (2) interfaces side-by-side in 1-RU space.
- 2) **Product Info:**
Logo, Name, Part Number FCC and CE Marks and standard FCC disclaimer language (exciting stuff)...

INSTALLATION PROCEDURES

Before Installing:

- Choose a camera mounting location paying close attention to camera viewing angles, lighting conditions, possible line of site obstructions, and checking for in-wall obstructions where the camera is to be mounted. Always pick a mounting location that will *optimize* the performance of the camera.
- The CONCEAL wall mount for the PowerVIEW systems can be mounted directly to a 2-gang wall box or can be mounted using only dry wall anchors.

RS-232 Cabling Notes:

For RS-232 cabling, use a standard Cat-5 cable with real RJ-45 connectors (568B termination) from the RS-232 'TO CAMERA' port on the back of the Quick-Connect DVI/HDMI SR interface to the camera's RS-232 - IR OUT Port. If the camera is connected to a third-party control system (such as AMX or Crestron), a DE-9F (also called a DB-9F in some circles) to RJ-45F control adapter is supplied.

 **More Notes:** Use of pass-thru type RJ-45 connectors is *highly discouraged*. The Vaddio Cat-5 wiring standard uses pins 1, 2, 7 and 8 on both the power/video and the control Cat-5 cables. The pass-through connectors have proven to provide insufficient connectivity for these important signals. They are OK for voice and data that use the center pins only, but not for cabling systems that use all the pins.

Installation Basics:

This camera system was specifically designed for installation on a vertical wall surface with Cat-5 cable connectivity for Video, Power and Control signaling (two Cat-5 cables are required with the QDVI system). This cabling ideology is especially convenient when the camera location is not anywhere near to an AC outlet. Installation is simplified in that no custom 8-Pin mini-din cables or expensive plenum coax cables or multi-pin cables are needed and no power outlets are required near the camera bracket. All Cat-5 cabling is routed to the head-end using with standard straight through RJ-45 connectors (568B termination). *"Pass-thru" type RJ-45 connectors should be avoided, like standing on a ladder to wave to the OSHA inspector, which should be avoided too.*



General Installation Instructions for the CONCEAL Wall Mounting System:

Step 1: Determine Camera Mount Location and Mount

After determining the optimum location of the camera system, route both (2) required Cat-5 cables from the camera to the head-end. Test and mark the cables **Power/Video** and **RS-232** accordingly.

Both Cat-5 cables should feed-through a 1" (25.4mm) opening (circular or square shape) centered in the rectangular slot located on the rear flange of the CONCEAL Wall Mount Bracket.

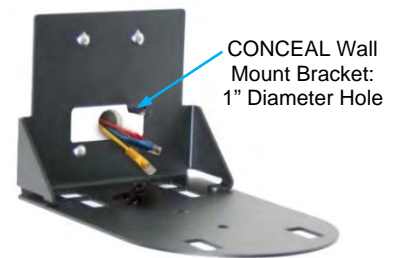

Note: Please do not cut out the entire rectangular slot opening in the wall. This will not allow the two lower wall anchors to correctly fasten the CONCEAL bracket to the wall.

If the bracket is to be mounted on a 2-gang wall box, use the screws supplied with the wall box cover plate to attach the CONCEAL Wall Mount Bracket. If mounting to drywall with wall anchors, use the four (4) quality wall anchors/screws provided.



The mounting holes are slotted and are 90° opposing to provide easy leveling. Level the mount and place the camera on the mount. The example of the CONCEAL mount shows a different Vaddio Camera, but the steps are identical for the HD-22 or HD-30.

Camera aligned and attached to the CONCEAL Wall Mount Bracket (by two 1/4"-20) screws in the bottom of the mount).



Step 2: System Wiring

Follow the sample wiring diagrams for connecting the Cat-5 cables to the camera and Quick-Connect DVI/HDMI SR Interface. Additional diagrams are available on the Vaddio website.

Connect the camera side as follows:

- Connect the Power/Video Cat-5 to the EZ POWER HD VIDEO RJ-45 jack on the back of the camera.
- Connect the RS-232 Control Cat-5 to the RS-232 IR OUT RJ-45 on the camera.

Connect the Quick-Connect DVI/HDMI-SR side as follows:

- Connect the Power/Video Cat-5 to the EZCAMERA POWER & HD VIDEO RJ-45 jack.
- Connect the RS-232 Cat-5 cable to the RS-232 'TO CAMERA' RJ-45 jack and connect the controller, or console to the RS-232 INPUT.
- The controller can be routed directly to the camera if preferred. For IR Forwarding, the RS-232 cable must be routed through the Quick-Connect SR in order to operate correctly (see pin-out section)
- Connect the video outputs (HD-YPbPr or HDMI/DVI) to the desired video console or display.



Note: Please check all Cat-5 cables for continuity in advance of final connection. Plugging the POWER/VIDEO Cat-5 cable into the wrong RJ-45 may cause damage to the camera system and void the warranty!

Step 3: Secure the Camera To the CONCEAL Wall Mount Bracket

After all cables are attached to the camera, slide the camera back onto mount and insert the two 1/4"-20 screws into the camera through the two-screw slots in the bottom of the mount. **Note:** Be sure to align each side of the camera evenly for the best fit prior to tightening down the mounting screws.

Step 4: Install the CONCEAL Lower Cover Plate

Attach the CONCEAL lower cover plate. Slide the lower cover plate from front of the mounting bracket toward the rear of the bracket. The two (2) rear locking tabs will need to be guided into position first and will lock in place as the lower cover plate is pushed toward the rear of the mounting bracket. The two (2) front tabs will engage as the cover is pushed back into place.

CONCEAL Lower Cover Plate with Locking Tabs



CONCEAL Lower Cover Plate locked in place



Step 5: Install the CONCEAL Rear Camera Cover

Install the CONCEAL rear camera cover on the mounting bracket with the supplied screw.

CONCEAL Rear Camera Cover



Completed CONCEAL Wall Mount Camera Bracket Installation



NOTE (One more time!): Please verify that the Cat-5 cables are plugged in correctly. Plugging the wrong cable into the wrong jack may cause confounding bewilderment (in general).

Step 6: Connect System Power

Connect the 24 VDC power supply to the Quick-Connect DVI/HDMI SR Interface and the AC plug into an AC outlet. The Quick-Connect will power the camera via the Power/Video Cat-5 cable. The camera will "Home" to a centered position (or stored preset home position if one is set) and will output video when it has completely booted up. The PowerVIEW is now ready for control information from a controller or IR Remote Commander.

Boot Order Notes: When using a joystick controller or external control system, in order to ensure proper continuity of camera control, the RS-232 controller should be powered-on after the camera. In most, if not all cases, the camera needs to be on and running in order for communication to take place between the camera and controller. When plugging a new camera into a RS-232 controller/joystick that has already been powered up, a system reboot or camera rescan may be necessary to find the camera.

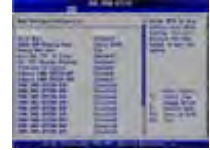
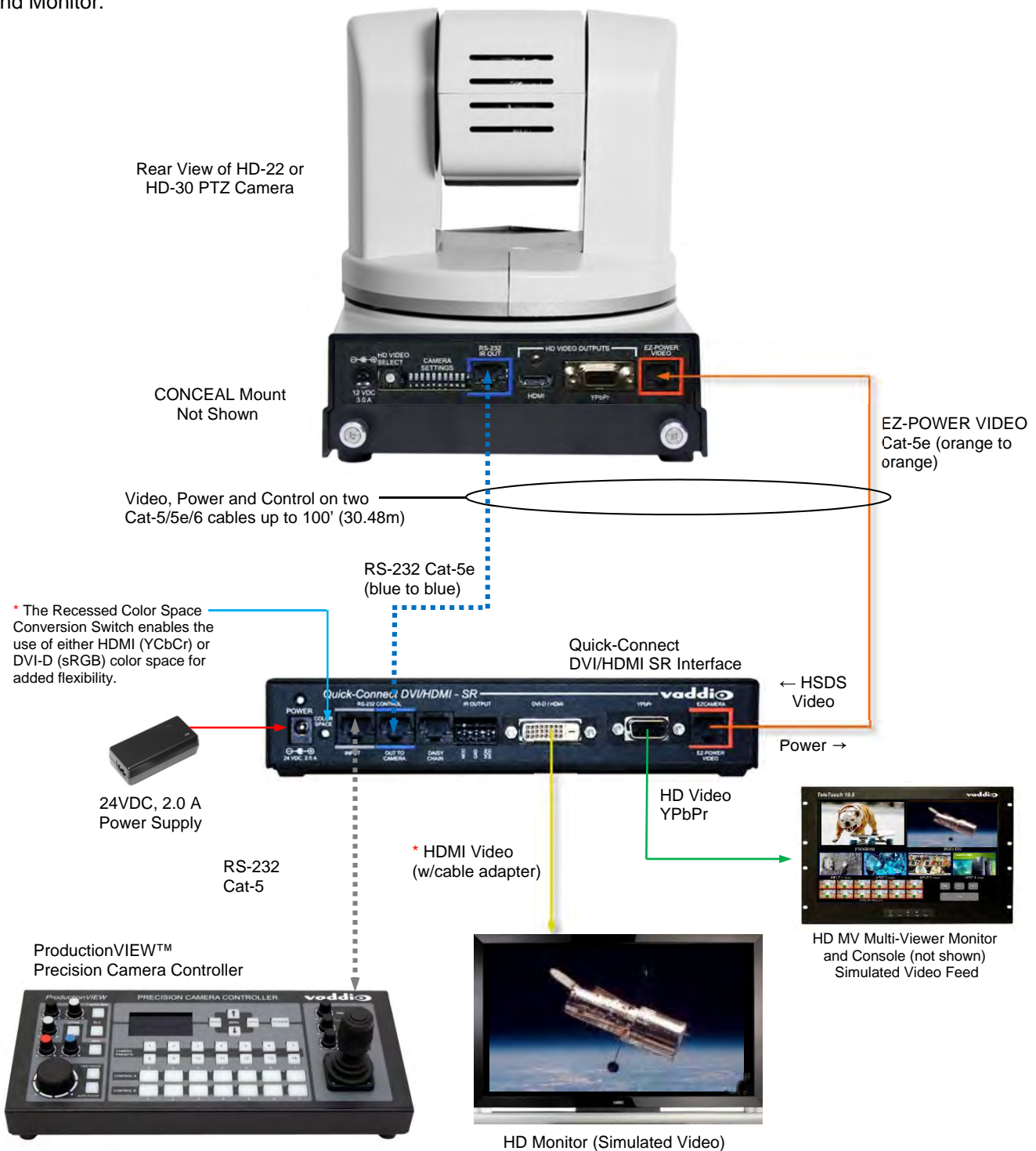

Image: Basic Connectivity Example of the HD-22 or HD-30

Camera Connected to Quick-Connect DVI/HDMI-SR Interface, ProductionVIEW™ Precision Camera Controller and Monitor.



DAISY CHAIN CONFIGURATIONS

In some cases, daisy chain control situations just can't be avoided. Because of this, Vaddio added "Daisy Chain Control Emulation" or DCCE™ to the Quick-Connect DVI/HDMI SR Interface in order to use the ClearVIEW or PowerVIEW series cameras daisy chain control situations. Hardware codecs (Cisco & Polycom) that control cameras using a daisy chain control topology are prime examples of where DCCE can be used.

- 1) For daisy chain control, first complete steps above, since all the cabling between the camera and the Quick-Connect DVI/HDMI Interface is the same.
- 2) Instead of running a control cable from the 1st camera to the 2nd camera to form a daisy chain, run a Cat-5e patch cable from the 1st Quick-Connect DVI/HDMI Interface's RS-232 CONTROL - DAISY CHAIN RJ-45 jack, to the 2nd Quick-Connect DVI-HDMI SR Interface's RS-232 CONTROL INPUT RJ-45 jack.
- 3) Within the modified VISCA® protocol that the codec and the ClearVIEW and PowerVIEW cameras use, the 1st in the chain will set up as Camera #1, the second will set up as Camera #2 in the chain, allowing the controller or hardware codec's IR remote (using the IR Forwarding Feature) to select which camera it will switch to and which to control.
- 4) In the case of Cisco codecs, use the IR Modulated output of the Quick-Connect and a Xantech IR emitter (282D or 283D) and attach the emitter to the front panel of the codec (in front of the IR receiver).
- 5) Polycom codecs with IR receivers can connect the IR feed-through the same way as the Cisco, but do not use daisy chain control. Several Polycom codecs can also be connected directly with the non-modulated signal to the codec's IR signal input port.

Basic Daisy Chain Connectivity:

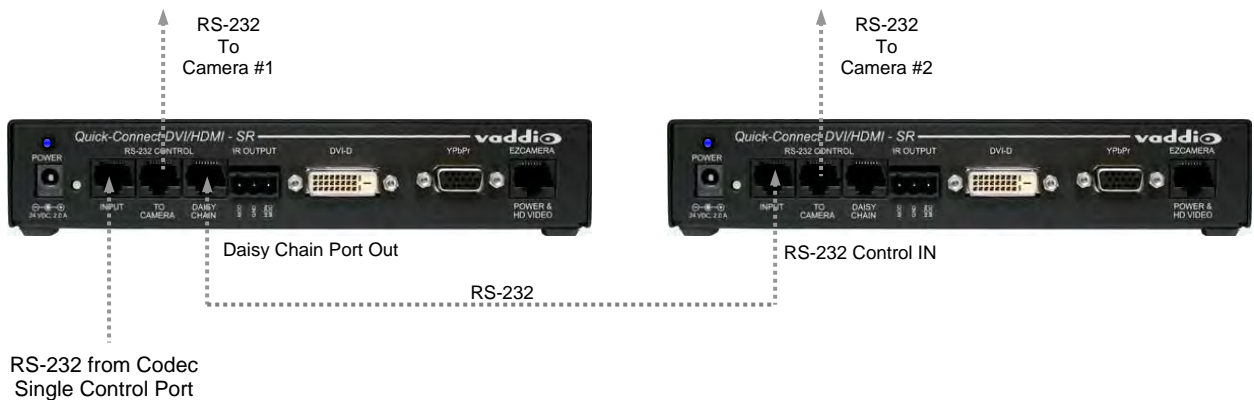

COMPLIANCE AND CE DECLARATION OF CONFORMITY - POWERVIEW HD-22 AND HD30

Compliance testing was performed to the following regulations:

- **FCC Part 15 (15.107, 15.109), Subpart B**
- **ICES-003, Issue 4: 2004**
- **EN 55022 A: 2006 + A1: 2007**
- **KN24 2008 (CISPR 24: 1997 + A1: 2000 + A2: 2002)**
- **KN22 2008 (CISPR 22: 2006)**
- **EMC Directive 2004/108/EC**
- **EN 55024: A2: 2003**

- Class A
- Class A
- Class A
- Class A
- Class A
- Class A
- Class A



FCC Part 15 Compliance

This equipment has been tested and found to comply with the limits for a Class A digital device, pursuant to Part 15, Subpart B, of the FCC Rules. These limits are designed to provide reasonable protection against harmful interference when the equipment is operated in a commercial environment. This equipment generates, uses, and can radiate radio frequency energy and, if not installed and used in accordance with the instruction manual, may cause harmful interference to radio communications. Operation of this equipment in a residential area is likely to cause harmful interference in which case the user will be required to correct the interference at his/her own expense.

Operation is subject to the following two conditions: (1) This device may not cause interference, and (2) This device must accept any interference including interference that may cause undesired operation of the device. Changes or modifications not expressly approved by Vaddio can affect emission compliance and could void the user's authority to operate this equipment.



ICES-003 Compliance

This digital apparatus does not exceed the Class A limits for radio noise emissions from digital apparatus set out in the Radio Interference Regulations of the Canadian Department of Communications.
Le présent appareil numérique n'émet pas de bruits radioélectriques dépassant les limites applicables aux appareils numériques de la classe A prescrites dans le Règlement sur le brouillage radioélectrique édicté par le ministère des Communications du Canada.



European Compliance

This product has been evaluated for Electromagnetic Compatibility under the EMC Directive for Emissions and Immunity and meets the requirements for a Class A digital device. In a domestic environment this product may cause radio interference in which case the user may be required to take adequate measures.

Standard(s) To Which Conformity Is Declared:

EMC Directive 2004/108/EC

EN 55022 A: 2006 + A1: 2007(CISPR 22:2005/A1:2005)

EN 55024: 1998 + Amendments A1: 2001 + A2: 2003

- EN 61000-4-2: 1995 + Amendments A1: 1998 + A2: 2001
- EN 61000-4-3: 2006 + A1: 2008
- EN 61000-4-4: 2004 + Corrigendum 2006
- EN 61000-4-5: 2006
- EN 61000-4-6: 2009
- EN 61000-4-8: 2010
- EN 61000-4-11: 2004

KN24 2008 (CISPR 24: 1997 + A1: 2000 + A2: 2002)

- EN 61000-4-2
- EN 61000-4-3
- EN 61000-4-4
- EN 61000-4-5
- EN 61000-4-6
- EN 61000-4-8
- EN 61000-4-11

IEC 60950-1:2005 (2nd Edition); Am 1:2009

EN 60950-1:2006+A11:2009+A1:2010+A12:2011

- Conducted and Radiated Emissions
- Immunity
- Electrostatic Discharge
- Radiated Immunity
- Electrical Fast Transients
- Surge Immunity
- Conducted Immunity
- Power Frequency Magnetic Field
- Voltage Dips, Interrupts and Fluctuations
- IT Immunity Characteristics
- Electrostatic Discharge
- Radiated Immunity
- Electrical Fast Transients
- Surge Immunity
- Conducted Immunity
- Power Frequency Magnetic Field
- Voltage Dips, Interrupts and Fluctuations
- Safety
- Safety

COMPLIANCE AND CE DECLARATION OF CONFORMITY - QUICK-CONNECT DVI/HDMI SR INTERFACE

Compliance testing was performed to the following regulations:

- **FCC Part 15, Subpart B**
- **ICES-003, Issue 4: 2004**
- **European Standard EN 55022 A: 2006 + A1: 2007(CISPR 22:2005/A1:2005)**
- **EMC Directive 2004/108/EC**

Class A
 Class A
 Class A
 Class A



FCC Part 15 Compliance

- This equipment has been tested and found to comply with the limits for a Class A digital device, pursuant to Part 15, Subpart B, of the FCC Rules. These limits are designed to provide reasonable protection against harmful interference when the equipment is operated in a commercial environment. This equipment generates, uses, and can radiate radio frequency energy and, if not installed and used in accordance with the instruction manual, may cause harmful interference to radio communications. Operation of this equipment in a residential area is likely to cause harmful interference in which case the user will be required to correct the interference at his/her own expense.
- Operation is subject to the following two conditions: (1) This device may not cause interference, and (2) This device must accept any interference including interference that may cause undesired operation of the device.
- Changes or modifications not expressly approved by Vaddio can affect emission compliance and could void the user's authority to operate this equipment.



ICES-003 Compliance

This digital apparatus does not exceed the Class A limits for radio noise emissions from digital apparatus set out in the Radio Interference Regulations of the Canadian Department of Communications.

Le présent appareil numérique n'émet pas de bruits radioélectriques dépassant les limites applicables aux appareils numériques de la classe A prescrites dans le Règlement sur le brouillage radioélectrique édicté par le ministère des Communications du Canada.



European Compliance

This product has been evaluated for Electromagnetic Compatibility under the EMC Directive for Emissions and Immunity and meets the requirements for a Class A digital device. In a domestic environment this product may cause radio interference in which case the user may be required to take adequate measures.

Ferrite cylinders are included in order to the Quick-Connect DVI/HDMI SR Interface to strictly comply with the European Community EMC Directives compliance. Use these ferrites to ensure the elimination of possible EMI interference from cell phones and AC motors.

Standard(s) To Which Conformity Is Declared:

EMC Directive 2004/108/EC

EN 55022 A: 2006 + A1 2007 (CISPR 22:2005/A1:2005) Conducted and Radiated Emissions

EN 55024: 1998 + Amendments A1: 2001 + A2: 2003 - Electromagnetic Compatibility - Immunity

- EN 61000-4-2** Electrostatic Discharge
- EN 61000-4-3** Radiated Immunity
- EN 61000-4-4** Electrical Fast Transients
- EN 61000-4-5** Surge Immunity
- EN 61000-4-6** Conducted Immunity
- EN 61000-4-8** Power Frequency Magnetic Field
- EN 61000-4-11** Voltage Dips, Interrupts and Fluctuations

WARRANTY INFORMATION

(See Vaddio Warranty, Service and Return Policies posted on vaddio.com for complete details):

Hardware* Warranty: Two (2) year limited warranty on all parts and labor for Vaddio manufactured products. Vaddio warrants its manufactured products against defects in materials and workmanship for a period of two years from the day of purchase, to the original purchaser, if Vaddio receives notice of such defects during the warranty. Vaddio, at its option, will repair or replace products that prove to be defective. Vaddio manufactures its hardware products from parts and components that are new or equivalent to new in accordance with industry standard practices.

Exclusions: The above warranty shall not apply to defects resulting from improper or inadequate maintenance by the customer, customers applied software or interfacing, unauthorized modifications or misuse, mishandling, operation outside the normal environmental specifications for the product, use of the incorrect power supply, modified power supply or improper site operation and maintenance. OEM products and products manufactured by other companies are excluded and are covered by the manufacturer's warranty.

Vaddio Customer Service: Vaddio will test, repair, or replace the product or products without charge if the unit is under warranty. If the product is out of warranty, Vaddio will test then repair the product or products. The cost of parts and labor charge will be estimated by a technician and confirmed by the customer prior to repair. All components must be returned for testing as a complete unit. Vaddio will not accept responsibility for shipment after it has left the premises.

Vaddio Technical Support: Vaddio technicians will determine and discuss with the customer the criteria for repair costs and/or replacement. Vaddio Technical Support can be contacted through one of the following resources: e-mail support at support@vaddio.com or online at vaddio.com.

Return Material Authorization (RMA) Number: Before returning a product for repair or replacement request an RMA from Vaddio's technical support. Provide the technician with a return phone number, e-mail address, shipping address, product serial numbers and original purchase order number. Describe the reason for repairs or returns as well as the date of purchase. See the General RMA Terms and Procedures section for more information. RMA's are valid for 30 days and will be issued to Vaddio dealers only. End users must return products through Vaddio dealers. Include the assigned RMA number in all correspondence with Vaddio. Write the assigned RMA number clearly on the shipping label of the box when returning the product. All products returned for credit are subject to a restocking charge without exception.

Voided Warranty: The warranty does not apply if the original serial number has been removed or if the product has been disassembled or damaged through misuse, accident, modifications, use of incorrect power supply, use of a modified power supply or unauthorized repair.

Shipping and Handling: Vaddio will not pay for inbound shipping transportation or insurance charges or accept any responsibility for laws and ordinances from inbound transit. Vaddio will pay for outbound shipping, transportation, and insurance charges for all items under warranty but will not assume responsibility for loss and/or damage by the outbound freight carrier. If the return shipment appears damaged, retain the original boxes and packing material for inspection by the carrier. *Contact your carrier immediately.*

Products not under Warranty: Payment arrangements are required before outbound shipment for all out of warranty products.

*Vaddio manufactures its hardware products from parts and components that are new or equivalent to new in accordance with industry standard practices.

Other General Information:

Care and Cleaning

Do not attempt to take this product apart at any time. There are no user-serviceable components inside.

- Do not spill liquids in the product
- Keep this device away from food and liquid
- For smears or smudges on the product, wipe with a clean, soft cloth
- Use a lens cleaner on the lens...
- Do not use any abrasive chemicals.

Operating and Storage Conditions:

Do not store or operate the device under the following conditions:

- Temperatures above 40°C (104°F) or temperatures below 0°C (32°F)
- High humidity, condensing or wet environments
- In inclement weather
- In swimming pools or drainage culverts (lack of light)
- Dry environments with an excess of static discharge
- In an aluminum canoe (moisture issue)
- Under severe vibration

GENERAL SPECIFICATIONS

Camera	PowerVIEW HD-22 PTZ	PowerVIEW HD-30 PTZ
Part Numbers	999-6960-000 (North America) 999-6960-001 (Int'l)	999-6970-000 (North America) 999-6970-001 (Int'l)
Zoom	22X Optical Zoom	30X Optical Zoom
Field of View	Horizontal: 65.2° Wide End to 3.1° Tele (16:9 Aspect Ratio)	Horizontal: 65° Wide End to 2.2° Tele (16:9 Aspect Ratio)
Lens Focal Length	f=4.3 mm to 94.6 mm / F1.6 - F4.7	f=4.3mm to 129.0 mm / F1.6- F4.7
Image Sensor	1/2.8-Type MOS, 2.2 Megapixel, Progressive Scan	
Minimum Illumination	Color: 0.4 lux (F1.6, 1/30 sec, 50 IRE, Gain: High), B/W: 0.04 lux (F1.6, 1/30 sec, 50 IRE, Gain: High)	
Video Resolutions	HD: 1080p/59.94, 1080p/50, 1080p/29.97/25, 1080i/59.94, 1080i/50, 720p/59.94, 720p/50 SD: 480p/59.97 and 576p/50	
Video Output Formats	HDMI (YCbCr for HDMI and sRGB for DVI), Analog Component (YPbPr) HSDS (Power, Differential HD Video & R&S-232 Control)	
Signal to Noise Ratio	> 50 dB (AGC: Off)	
PowerVIEW HD-22/30 Quick-Connect	Quick-Connect DVI/HDMI SR Part Number 998-1105-018	
Pan Range	Pan: +170 degrees to -170 degrees Tilt: +90 degrees to -30 degrees	
Preset Positions	16 (internal), 6 recalled via Vaddio IR Remote Commander	
Image Control	Red & Blue Gain, Detail, Chroma, Gamma, Pedestal, Iris, and Gain (Controls available through RS-232 control and Quick-Connect CCU and Slot Card)	
Tally Light	Available through RS-232 Control	
HD Video Select	16-Position Rotary Switch: Used to set HD Video Resolution Output	
Camera Settings	10-Position Dip Switch: Settings for IR Select, Baud Rate 9600, Image Flip, Unpublished Functions	
Accessory Slot Cards	EZIM CCU Slot Card PN# 999-6900-006 - For Use with Quick-Connect Universal CCU Only	
Dimensions/Weight	7.81" (198.37mm) H x 6.67" (169.42mm) W x 7.057" (179.25. mm) D / 5.6 lbs. (2.630835643 kg.)	
Quick-Connect DVI/HDMI-SR (Short Range) Interface		
Connectors	<ul style="list-style-type: none"> Power Connector: 5.5mm OD, 2.5mm ID coaxial connector RJ-45: Four (4) Control IN, Control OUT, Daisy Chain OUT, EZCamera Power Video Port Video Output: DE-15 connector for HD Analog Component (Y,PB,PR) video only (No SD Support) IR Output: Transmits modulated or non-modulated IR signals received from the HD-19 IR receiver Video Outputs: DVI-D (Female - Single Link) or HDMI with adapter cable (using the Recessed Color Space Conversion Switch) , DE-15F (High Density D-Sub 15-Pin F) for HD YPbPr 	
Cat-5 Cable Distance	Up to 100' (30.5m)	
Power Supply	24 VDC, 2.0 Amp Switching Power Supply	
Dimensions / Weight	1.6" (40.64mm) H x 8" (203.2mm) W x 6.751" (171.45mm) D, ½-Rack Size / 1.21 lbs. (0.548846804 kg)	
Accessory Options	1-RU Rack Mount Panel for two (2) units (side by side): P/N: 998-6000-003 1m (3.3') DVI-D Male to HDMI Male P/N: 440-5643-001 3m (10') DVI-D Male to HDMI Male P/N: 440-5643-003	
CONCEAL Wall Mounting System		
Dimensions	5.125" H x 6.75" W x 10" D (13 cm x 17.15 cm x 25.4 cm)	
Weight	Approx. 2.4 lbs. (1.1kg)	

Moon in Front Page Header: Umbriel - Moon of the planet Uranus (tinted blue to expose detail).

APPENDIX 1: PIN-OUTS FOR THE HD-22/30 CAMERA

Pin	YPbPr
1	Pr
2	Y
3	Pb
4	-
5	-
6	Pr GND
7	Y GND
8	Pb GND
9	-
10	GND
11	-
12	-
13	-
14	-
15	-

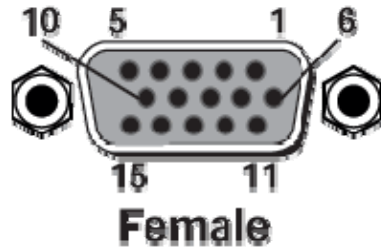

EZ-POWER Video RJ-45 Connector Pin-outs



Important Note: The EZ POWER HD VIDEO RJ-45 Connector is for use with the **Quick-Connect SR**, **Quick-Connect DVI/HDMI SR** and **Quick-Connect USB** Interfaces ONLY (568B Wiring Standard). The video signals are differential (HSDS™) and can only be received by the interfaces above.

Pin	Signal
1	Power+
2	Power-
3	Y+
4	PB+
5	PB -
6	Y -
7	PR+
8	PR-

EZ-POWER VIDEO

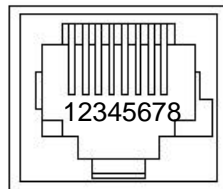

RS-232, IR OUT on Camera HD-22/30 - RJ-45

Pin #	Function
Pin - 1	N/A
Pin - 2	N/A
Pin - 3	N/A
Pin - 4	IR Output (Diff Signal to Quick-Connect DVI/HDMI-SR)
Pin - 5	IR Ground (Diff Signal to Quick-Connect DVI/HDMI-SR)
Pin - 6	Digital GND
Pin - 7	RXD (from TXD of control source)
Pin - 8	TXD (to RXD of control source)

RS-232 IR OUT

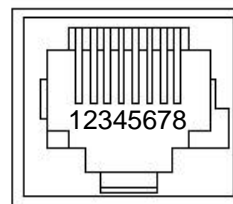

Drawing: PowerVIEW HD-22/30 Camera Dimensions

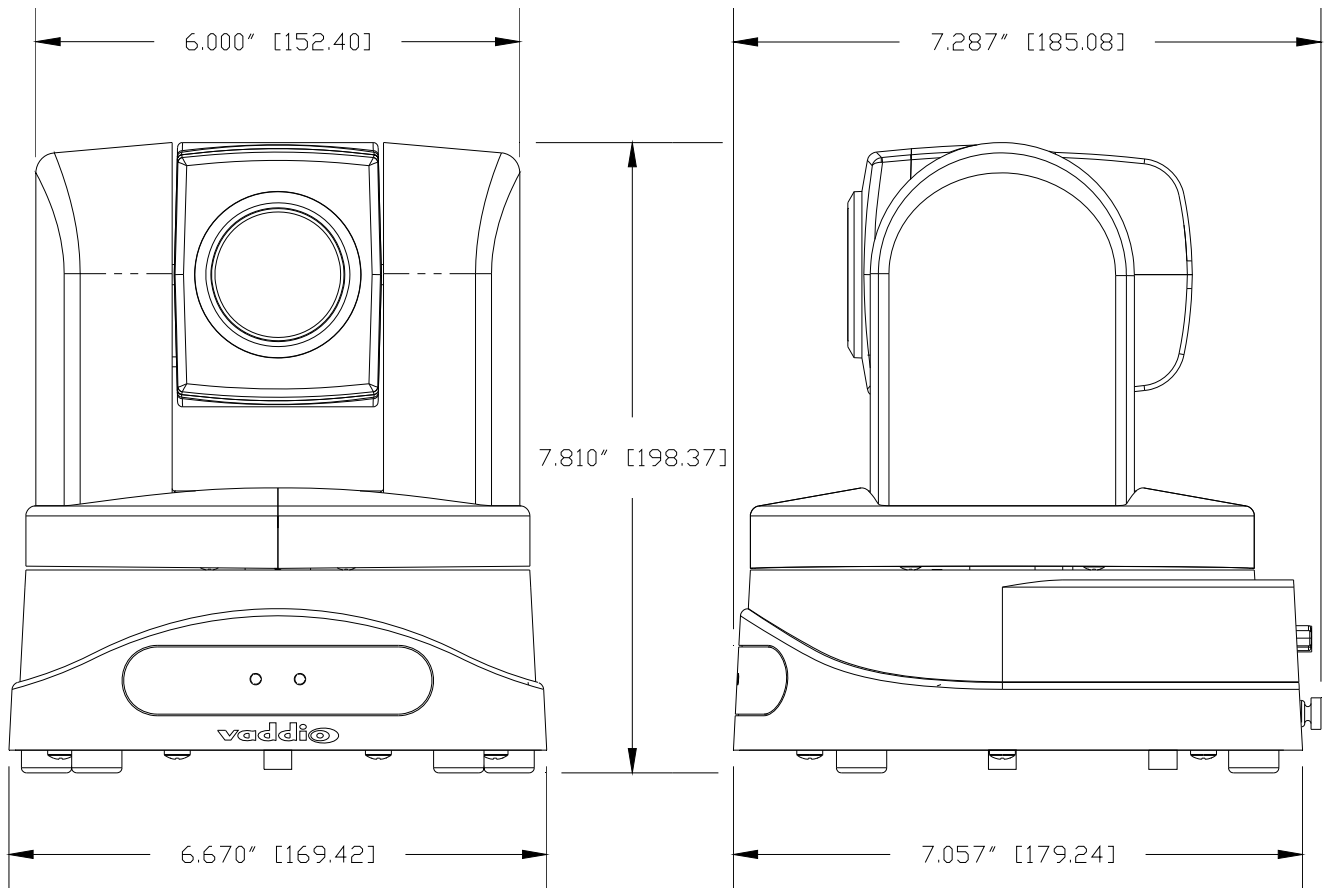

COMMUNICATION SPECIFICATION

Communication Speed: 9600 bps (default)

Start bit: 1

Stop bit: 1

Data bits: 8

Parity: None

No Flow control

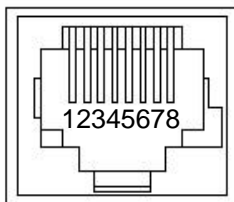

Pin #	Function
Pin - 1	N/A
Pin - 2	N/A
Pin - 3	N/A
Pin - 4	IR Output (Diff Signal to Quick-Connect DVI/HDMI-SR)
Pin - 5	IR Ground (Diff Signal to Quick-Connect DVI/HDMI-SR)
Pin - 6	Digital GND
Pin - 7	RXD (from TXD of control source)
Pin - 8	TXD (to RXD of control source)

NOTE: The Vaddio PowerVIEW HD-22 and 30Control Protocol is similar, but not identical to, the Sony® VISCA™ command set in order to be compatible with several popular control devices. Not all VISCA commands are supported and there are many HD-22/30 specific commands in the following Command and Inquiry Lists.

HD-22/30 Command List (1/2)

Command Set	Command	Command Packet	Comments
Address Set	Broadcast	88 30 01 FF	Address Set (Daisy chain)
IF_Clear	Broadcast	88 01 00 01 FF	IF Clear
Command Cancel		8x 2p FF	p:socket number(1,2)
CAM_Power	On Off(Standby)	8x 01 04 00 02 FF 8x 01 04 00 03 FF	Power On/Off
CAM_Zoom	Stop Tele(Standard) Wide(Standard) Tele(Variable) Wide(Variable) Direct	8x 01 04 07 00 FF 8x 01 04 07 02 FF 8x 01 04 07 03 FF 8x 01 04 07 2p FF 8x 01 04 07 3p FF 8x 01 04 47 00 0p 0q 0r FF	p:(1-Slow to 4-Fast) p:(1-Slow to 4-Fast) pqr: Zoom Position*
CAM_Focus	Stop Far(Standard) Near(Standard) Far(Variable) Near(Variable) AutoFocus ManualFocus Auto/Manual Direct	8x 01 04 08 00 FF 8x 01 04 08 02 FF 8x 01 04 08 03 FF 8x 01 04 08 2p FF 8x 01 04 08 3p FF 8x 01 04 38 02 FF 8x 01 04 38 03 FF 8x 01 04 38 10 FF 8x 01 04 48 0p 0q 0r 0s FF	p:(1-Slow to 4-Fast) p:(1-Slow to 4-Fast) pqrs: Focus position(0-0x438)*
CAM_WB	Auto Indoor Outdoor One Push WB Manual Fluorescent One Push Trigger	8x 01 04 35 00 FF 8x 01 04 35 01 FF 8x 01 04 35 02 FF 8x 01 04 35 03 FF 8x 01 04 35 05 FF 8x 01 04 35 06 FF 8x 01 04 10 05 FF	Normal Auto (Auto Tracing WB) Indoor Mode (Color Temp 3200K) Outdoor Mode (Color Temp 5600K) One Push White Balance Mode Manual White Balance Fluorescent(Color Temp 4200K) One Push WB Trigger
CAM_RGain	Reset Up Down Direct	8x 01 04 03 00 FF 8x 01 04 03 02 FF 8x 01 04 03 03 FF 8x 01 04 43 00 00 0p 0q FF	pq:00-ff
CAM_BGain	Reset Up Down Direct	8x 01 04 04 00 FF 8x 01 04 04 02 FF 8x 01 04 04 03 FF 8x 01 04 44 00 00 0p 0q FF	pq:00-ff
CAM_AE	Full Auto Manual	8x 01 04 39 00 FF 8x 01 04 39 03 FF	Auto Exposure Mode Manual Control Mode
CAM_Iris	Reset Up Down Direct	8x 01 04 0B 00 FF 8x 01 04 0B 02 FF 8x 01 04 0B 03 FF 8x 01 04 4B 00 00 0p 0q FF	pq(0x00-0xFF)
CAM_Gain	Reset Up Down Direct	8x 01 04 0C 00 FF 8x 01 04 0C 02 FF 8x 01 04 0C 03 FF 8x 01 04 4C 00 00 0p 0q FF	pq(0x00-0xFF)
CAM_Backlight	On Off	8x 01 04 33 02 FF 8x 01 04 33 03 FF	
CAM_Aperture	Reset Up Down Direct	8x 01 04 02 00 FF 8x 01 04 02 02 FF 8x 01 04 02 03 FF 8x 01 04 42 00 00 0p 0q FF	pq(0x00-0x3F)



HD-22/30 Command List (2/2)

Command Set	Command	Command Packet	Comments
CAM_Memory	Reset	8x 01 04 3F 00 0p FF	p:Memory No(=0-0xF)
	Set	8x 01 04 3F 01 0p FF	
	Recall	8x 01 04 3F 02 0p FF	
CAM_IDWrite		8x 01 04 22 0p 0q 0r 0s FF	pqrs:0x0000 – 0xFFFF
CAM_LR_Reverse	On	8x 01 04 61 02 FF	Mirror (Horizontal) on
	Off	8x 01 04 61 03 FF	Mirror (Horizontal) off
CAM_Freeze	On	8x 01 04 62 02 FF	Still image on
	Off	8x 01 04 62 03 FF	
CAM_PictureEffect	Color	8x 01 04 63 00 FF	
	B&W	8x 01 04 63 04 FF	
Pan-tiltDrive	Up	8x 01 06 01 VV WW 03 01 FF	VV: Pan Speed (0x01-0x18) WW: Tilt Speed(0x01-0x14) YYYY: Pan Position** ZZZZ: Tilt Position**
	Down	8x 01 06 01 VV WW 03 02 FF	
	Left	8x 01 06 01 VV WW 01 03 FF	
	Right	8x 01 06 01 VV WW 02 03 FF	
	UpLeft	8x 01 06 01 VV WW 01 01 FF	
	UpRight	8x 01 06 01 VV WW 02 01 FF	
	DownLeft	8x 01 06 01 VV WW 01 02 FF	
	DownRight	8x 01 06 01 VV WW 02 02 FF	
	Stop	8x 01 06 01 VV WW 03 03 FF	
	Absolute Position	8x 01 06 02 VV WW 0Y 0Y 0Y 0Y 0Z 0Z 0Z 0Z FF	
	Home	8x 01 06 04 FF	
Reset	8x 01 06 05 FF		
Tally	On	8x 01 7E 01 0A 00 02 FF	
	Off	8x 01 7E 01 0A 00 03 FF	
Preset Pan Speed	Pan/Tilt/Zoom Speed	8x 01 7E 01 0B WW SS ZZ FF	WW: Pan Speed (0x01-0x18) SS:Tilt Speed(0x01-0x14) ZZ:Zoom Speed(0-7);
Motor Config	Hard Motor Stops	8x 01 7E 01 70 00 00 FF	
	Soft Motor Stops	8x 01 7E 01 70 00 01 FF	
BLK.Enhance	Pedestal	8x 01 7E 53 00 00 0p 0q FF	Pq: Pedestal(0x00-0xFF)
GMA.Enhance	Gamma	8x 01 7E 54 00 00 0p 0q FF	pq: Gamma (0x00-0x03)
CRM.Enhance	Chroma	8x 01 7E 55 00 00 0p 0q FF	pq: Chroma (0x00-0xFF)
DIS.Enhance	Digital Image	8x 01 7E 57 02 FF	On Off
	Stabilizer	8x 01 7E 57 03 FF	
DNR.Enhance	Digital Noise	8x 01 7E 58 02 FF	On Off
	Reduction	8x 01 7E 58 03 FF	
AGC.Enhance	AGC Mode	8x 01 7E 59 00 FF	Off Manual AGC Gain (0dB) Low Medium High Low1 Low2 Med1 High1 Off p: Manual AGC Gain(1-0xE)***
		8x 01 7E 59 01 FF	
		8x 01 7E 59 02 FF	
		8x 01 7E 59 03 FF	
		8x 01 7E 59 04 FF	
		8x 01 7E 59 05 FF	
		8x 01 7E 59 06 FF	
		8x 01 7E 59 07 FF	
		8x 01 7E 59 00 0p FF	
CAM_ICR	ICR On	8x 01 04 01 02 FF	ICR On – Cut filter out B&W ICR Off – Cut filter in Color
	ICR Off	8x 01 04 01 03 FF	

***Zoom and Focus Data:**

CAM_Zoom: Range (0x000–0xA23/0xA73), HD22: 0xA23 (22x Zoom), HD30: 0xA73 (30x Zoom)

CAM_Focus: Range (0x000-0x438) dependent on Zoom Position

****Additional Information:**

Pan Range: 8044 – 7FBC (-32,700 to +32,700)

Tilt Range: E891 – 4C2B (-5,999 to +19,499)

Actual Pan/Tilt ranges defined in Inquiry list

HD-22/30 Inquiry List (1/1)

Inquiry Command	Command	Response Packet	Comments
CAM_PowerInq	8x 09 04 00 FF	y0 50 02 FF y0 50 03 FF	On Off(Standby)
CAM_ICRModelInq	8x 09 04 01 FF	y0 50 02 FF y0 50 03 FF	On - ICR filter Out Off – ICR filter In
CAM_BacklightModelInq	8x 09 04 33 FF	y0 50 02 FF y0 50 03 FF	On Off
CAM_WBModelInq	81 09 04 35 FF	y0 50 00 FF y0 50 01 FF y0 50 02 FF y0 50 03 FF y0 50 05 FF y0 50 06 FF	Auto Indoor Outdoor One Push WB Manual Fluorescent
CAM_AEModelInq	8x 09 04 39 FF	y0 50 00 FF y0 50 03 FF	Auto Exposure Mode Manual Control Mode
CAM_LR_Reverse	8x 09 04 61 FF	y0 50 02 FF y0 50 03 FF	On Off
CAM_Freeze	8x 09 04 62 FF	y0 50 02 FF y0 50 03 FF	On Off
CAM_PictureEffect	8x 09 04 63 FF	y0 50 00 FF y0 50 04 FF	Off B&W
CAM_MemoryInq	8x 09 04 3F FF	y0 50 0p FF	p: Preset 0-0xf
CAM_IDInq	8x 09 04 22 FF	y0 50 0p 0q 0r 0s FF	pqr: 0x0000 – 0xFFFF
CAM_ApertureInq	8x 09 04 42 FF	y0 50 00 00 0p 0q FF	Pq: x00-0x3F
CAM_RGain	8x 09 04 43 FF	y0 50 00 00 0p 0q FF	pq: 000-Off
CAM_BGain	8x 09 04 44 FF	y0 50 00 00 0p 0q FF	pq: 000-Off
CAM_ZoomPosInq	8x 09 04 47 FF	y0 50 0p 0q 0r 0s FF	pqr: 0-0x6B3
CAM_FocusPosInq	8x 09 04 48 FF	y0 50 0p 0q 0r 0s FF	pqr: Focus Position
CAM_FocusModelInq	8x 09 04 38 FF	y0 50 02 FF y0 50 03 FF	Auto Manual
CAM_Iris	8x 09 04 4B FF	y0 50 00 00 0p 0q FF	pq(0x00-0xFF)
CAM_Gain	8x 09 04 4C FF	y0 50 00 00 0p 0q FF	pq(0x00-0x24)
IR_ReceiveInq	8x 09 06 08 FF	y0 50 02 FF y0 50 03 FF	On Off
Pan-TiltMaxSpeedInq	8x 09 06 11 FF	y0 50 pp qq FF	pp: Pan 0x01-0x18 qq: Tilt 0x01-0x14
Pan-tiltPositionInq	8x 09 06 12 FF	FF y0 50 0p 0p 0p 0p 0q 0q 0q 0q FF	pppp: Pan 0x8044-0x7FB2 qqqq: Tilt 0xE890-0x4C2C
TallyInq	8x 09 7E 01 0A FF	y0 50 02 FF y0 50 03 FF	On Off
PresetSpeedInq	8x 09 7E 01 0B FF	y0 50 pp qq rr FF	pp: Pan 0x01-0x18 qq: Tilt 0x01-0x14 rr: Zoom 0x00-0x07
Motor Config	8x 09 7E 01 70 FF	y0 50 00 FF y0 50 01 FF	Hard Motor Stops Soft Motor Stops
BLK.Enhance	8x 09 7E 53 FF	y0 50 00 00 0p 0q FF	pq: Pedestal(0x00-0xFF)
GMA.Enhance	8x 09 7E 54 FF	y0 50 00 00 00 0p FF	p: Gamma (0x00-0x03)
CRM.Enhance	8x 09 7E 55 FF	y0 50 00 00 0p 0q FF	p: Chroma (0x00-0xFF)
KNE.Enhance	No support	No Support	Knee
DIS.Enhance	8x 09 7E 57 FF	y0 50 02 FF y0 50 03 FF	On Off
DNR.Enhance	8x 09 7E 58 FF	y0 50 02 FF y0 50 03 FF	On Off
AGC.Enhance	8x 09 7E 59 FF	y0 50 00 FF y0 50 01 FF y0 50 02 FF y0 50 03 FF y0 50 04 FF y0 50 05 FF y0 50 06 FF y0 50 07 FF y0 50 0p FF	Off Manual AGC Gain(0dB) Low Medium High Low1 Low2 Med1 High1 Off p: Manual AGC Gain(0-0x0e)***

***Manual AGC Gain: 0:0dB, 1:3dB, 2:6dB, 3:9dB, 4:12dB, 5:15dB, 6:18dB, 7:21dB, 8:24dB, 9:27dB, 10:30dB, 11:33dB, 12:36dB, 13:39dB & 14:42dB



Inside Rear Cover - Mostly Blank



Toll Free: 800-572-2011 ▪ Phone: 763-971-4400 ▪ FAX: 763-971-4464 ▪ vaddio.com