



Installation Guide for the

ConferenceSHOT FX

USB 3.0 Fixed Camera

Document 411-0015-31 Rev C
November 2020

Contents

Overview	1
What's in this Guide	1
Features	1
Unpacking the Camera	2
A Quick Look at the Camera	3
Front of the Camera	3
Back of the Camera	4
Installation	5
Don't Void Your Warranty!	5
Before You Install the Camera	5
Cabling Notes	6
Pre-Installation Functional Check	7
Status Indicator Light	8
Camera Behavior Settings	8
About Ceiling-Mounted Cameras	8
RS-232 Serial Communication Settings	9
RS-232 Connector Pin-Out	9
Installing the Wall Mount	10
Basic Connections	10
Installing the Camera	11
Powering Up the Camera	12
Next Steps	13
Operation, Storage, and Care	13
Compliance and Conformity Statements	14
FCC Part 15 Compliance	14
ICES-003 Compliance	14
European Compliance	15
Photo Credits	16
Index	17

Overview

This guide covers the ConferenceSHOT FX USB 3.0 fixed camera, worldwide part numbers 999-20000-000 (black) and 999-20000-000W (white).



What's in this Guide

This guide covers:

- Unpacking the camera
- Tips for a successful installation
- Instructions for installing the camera mount
- Information on connecting and mounting the camera
- Camera power-on

Complete product information is available in the **Integrator's Complete Guide to the ConferenceSHOT FX USB 3.0 Fixed Camera**.

Note

If you are responsible for configuring the equipment after installing it, please use the Complete Manual instead of this guide. The product's Complete Manual includes all the information in this guide, plus information on system administration, operation, and troubleshooting.

Features

- Fixed USB 3.0 camera for small to medium conference rooms
- 2 Megapixel, native 1080p/60 full HD image sensor
- 3x optical zoom, horizontal field of view of 88°
- Simultaneous uncompressed USB 3.0 and IP (H.264) streaming outputs at resolutions up to 1080p/60
- Selectable IP stream resolution; USB stream resolution auto-negotiated with conferencing client
- Universal Video Class (UVC) drivers supported in Windows®, macOS®, and Linux operating systems, compatible with most UC conferencing applications
- Integration-ready Telnet and serial RS-232 control
- Full administrative control via web interface; manage the camera remotely while monitoring the stream separately
- Presenter-friendly IR remote control

Unpacking the Camera

Make sure you received all the items you expected.

Caution:

Use the power supply shipped with or recommended for the camera. Using a different power supply may create an unsafe operating condition or damage the camera, and will void the warranty.

Caution

Always support the camera's body when lifting or moving it. Lifting the camera by its head or mounting arm will damage it.



The box should contain one of each item listed here:

- Camera (black or white)
- Thin Profile Wall Mount with mounting hardware (black or white)
- 12 VDC, 3 A switching power supply with AC cord sets
- USB 3.0 Type A to Type B cable, 6 ft. (1.8 m)
- Remote control
- Quick Start Guide



Older cameras were shipped with a different power supply.

A Quick Look at the Camera

This section covers the physical features of the camera.

Front of the Camera



Camera and zoom lens – The ConferenceSHOT FX camera features a 3X optical zoom lens.

IR sensor – Receives signals from the IR remote. Make sure there's nothing directly in front of the camera base, and point the remote at the camera.

Status light – The multi-colored LED indicates the camera's current state. This light can be turned off in the administrative web interface.

Note

By default, the camera's status indicator light is active during normal operation; however, it can be configured to remain off when the camera is powered up. The camera may be sending video even if the light is off.

Back of the Camera



- **12 VDC, 1.5 A** – EIAJ-04 jack. Connect only the power supply shipped with the camera or approved replacement 12 VDC, 3A power supply.
- **USB 3.0** – USB Type B connector. Connect to a computer for use with soft conferencing applications. Provides uncompressed USB 3.0 stream.
- **Ethernet** – RJ-45 connector. Connect to the network for IP streaming and camera control via web interface or Telnet.
- **Camera Settings** – DIP switches to set camera behaviors such as IR frequency, image flip (camera is invertible), normal or Super-Wide mode, and baud rate. See [Camera Behavior Settings](#).
- **RS-232** – RJ-45 connector. Connect to a controller to manage the camera using a modified VISCA protocol.

Installation

This section covers:

- Selecting the location for the camera
- Verifying that the camera is ready to install
- Installing the mount
- RS-232 cable pin-out and communication settings
- Connection diagrams
- Mounting the camera

Don't Void Your Warranty!



Caution

Always support the camera's body when lifting or moving it. Lifting the camera by its head or mounting arm will damage it.

Caution

This product is for indoor use. Do not install it outdoors or in a humid environment without the appropriate protective enclosure. Do not allow it to come into contact with any liquid.

Caution

Use the power supply included with the camera or recommended for use with it. Always check the output voltage listed on the power supply label, as power supplies of different voltages may look nearly identical. Using the wrong power supply will void the warranty, possibly causing unsafe operating conditions and damage to the product.

Caution

Do not install or operate this product if it has been dropped, damaged, or exposed to liquids. If any of these things happen, return it to Vaddio for safety and functional testing.

Before You Install the Camera

Things to keep in mind when deciding where to install the camera:

- Consider camera viewing angles, lighting conditions, line-of-sight obstructions, and in-wall obstructions where the camera is to be mounted.
- Ensure that the camera can be pointed appropriately from the desired location. The camera will not perform well if it is pointed toward a light source such as a light fixture or window.
- If the remote will be used, ensure that nothing blocks the IR lens in the camera's base.

Prepare for a successful installation:

- Be sure you can identify all cables correctly.
- Check Cat-5 cables for continuity.
- Ensure that the Settings switches are set appropriately.
- Talk to the network administrator. If installing the camera in a non-DHCP network (one that does not automatically assign IP addresses), you will need to configure the camera with a static IP address as directed by the network administrator.

Cabling Notes

Caution

When building cables for Vaddio products, do not use pass-through RJ-45 connectors. If they are crimped incorrectly, they can cause intermittent connections and degrade signal quality. Incorrectly crimped pass-through connectors can also damage the connectors on the product, which will void your warranty.



Intact – will make reliable contact with cable connector



Damaged – Bent contact fingers will NOT make reliable contact with cable connector

Use Cat-5e or better cable. We recommend using high-quality connectors and a high-quality crimping tool. We recommend shielded cabling if the cables will be coiled, run tightly with other cables, or routed near sources of electromagnetic interference such as power lines or fluorescent light fixtures.

Caution

Check your cables. Connecting a cable to the wrong port or using the wrong pin-out can result in equipment damage and will void the warranty.

Pro Tip

Label all cables at both ends.

Pre-Installation Functional Check

If you're installing the camera where it's hard to reach, you may want to verify functionality before you install it.

1. Connect the camera in its minimum functional configuration.



2. Connect power. The camera's indicator light turns blue.
3. Open a media player such as VLC Media Player and verify that the camera is available as a video capture device. (If you use VLC Media Player, this is the "Open Capture Device" option under Media.) The; the device name is ConferenceSHOT FX. Select the camera to view the USB stream.

The screen shots below show how you would access the USB stream using VLC Media Player. In this example, the capture device is a ConferenceSHOT 10 camera. The steps are the same for the ConferenceSHOT FX camera; only the video device name differs.

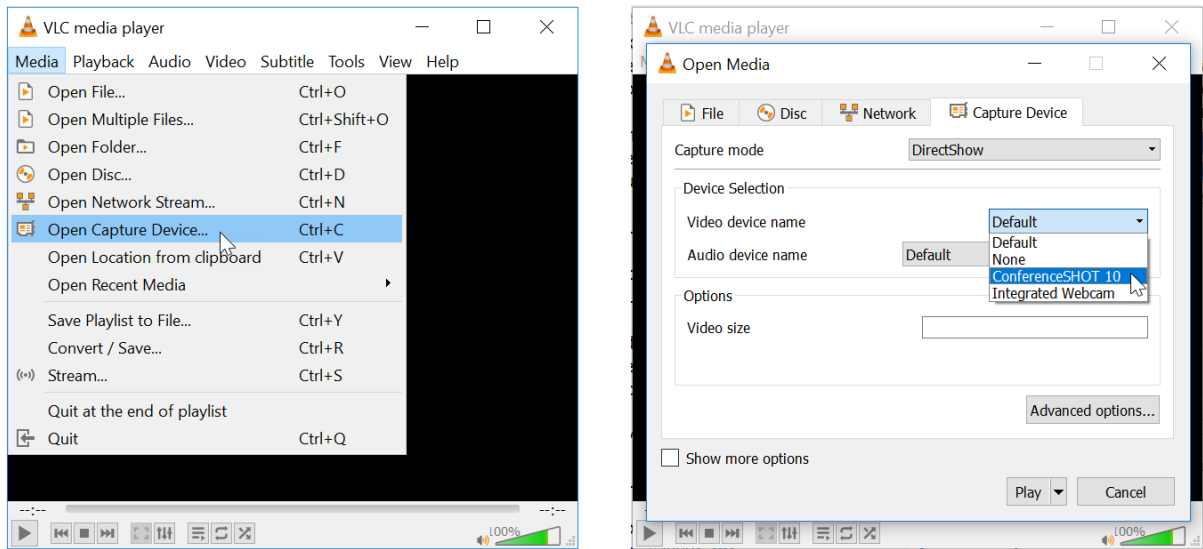

If the camera turns on and sends video, continue with the installation.

Status Indicator Light

The light in the camera's base indicates its current state.

- Blue – Camera is active
- Purple – Standby mode or booting
- Yellow – Firmware update is in progress
- Blinking blue – USB cable is disconnected (UC color scheme)

Caution

Do not remove power or reset the camera while the indicator is yellow, showing a firmware update in progress. Interrupting a firmware update can make the camera unusable.

Note

By default, the camera's status indicator light is active during normal operation; however, it can be configured to remain off when the camera is powered up. The camera may be sending video even if the light is off.

Camera Behavior Settings

The camera uses DIP switches to determine certain camera functions.

Note

When the camera is not inverted, DIP switches are in their default positions when they are up.

IR Frequency Selection (switches 1 and 2): The IR Remote Commander can control up to three cameras in the same room with different IR frequencies. Use **IR Settings** switches 1 and 2 to select the frequency to identify the camera as camera 1, 2, or 3; then use the Camera Select buttons at the top of the remote to select the camera you want to control.

- SW1 and SW2 up: IR frequency 1
- SW1 down, SW2 up: IR frequency 2
- SW1 up, SW2 down: IR frequency 3

Image Flip (switch 3): If mounting the camera upside-down, set Image Flip ON. This orients the video image correctly.

Switch 4 is not currently used.

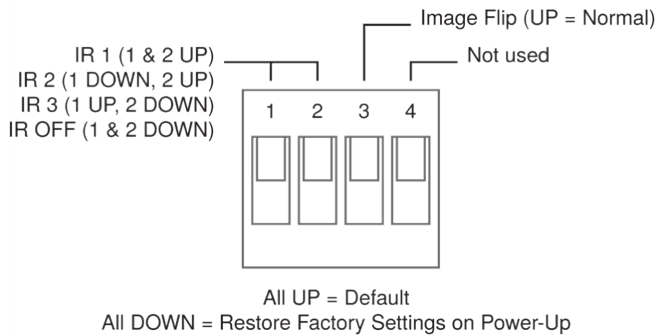

A label on the bottom of the camera provides a quick reference for setting the DIP switches.

About Ceiling-Mounted Cameras

If you use an inverted mount, set the camera's Image Flip DIP switch ON for inverted operation. This orients the video image correctly.

RS-232 Serial Communication Settings

The RS-232 serial port (RJ-45, color-coded blue) on the camera's back panel enables third-party control.

Parameter	Value
Communication Speed	9600 bps or 38400 bps, switch-selectable
Number of start bits	1
Number of stop bits	1
Number of data bits	8
Parity	None
Flow control	None

RS-232 Connector Pin-Out

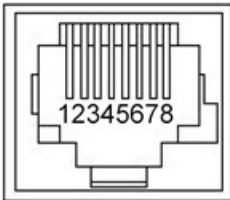

Connector pin-out:

- Pin 1: Not used
- Pin 2: Not used
- Pin 3: Not used
- Pin 4: Not used
- Pin 5: Not used
- Pin 6: GND
- Pin 7: RXD (from TXD of control source)
- Pin 8: TXD (to RXD of control source)

Caution

Check your cables. Connecting a cable to the wrong port or using the wrong pin-out can result in equipment damage and will void the warranty.

Installing the Wall Mount

The camera is shipped with a wall mount. Other mounting options are available as well. Contact us if you don't have the camera mount you need.

You can install the camera wall mount to a 2-gang wall box or directly to the drywall.

- If you mount it to drywall, use the wall anchors provided with the wall mount.
- If you mount it to a wall box, use the cover plate screws supplied with the wall box.

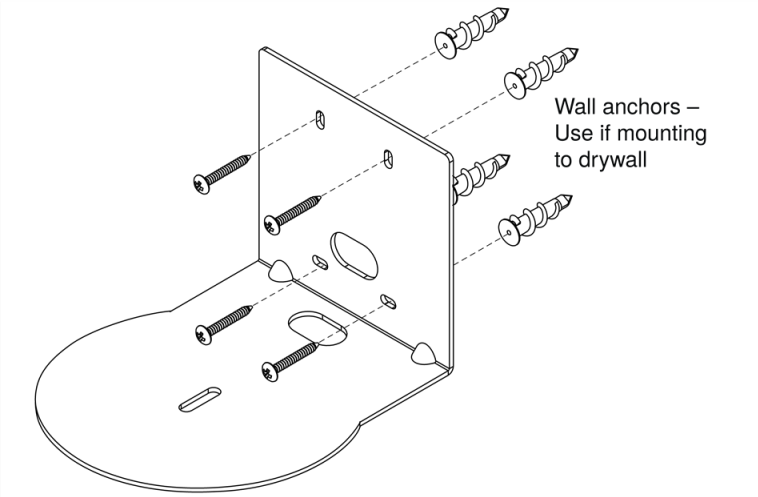

Basic Connections

Here is an example of how the camera might be set up in a conference room. In this setup, a computer uses a unified communications conferencing application with the camera and a conference phone.

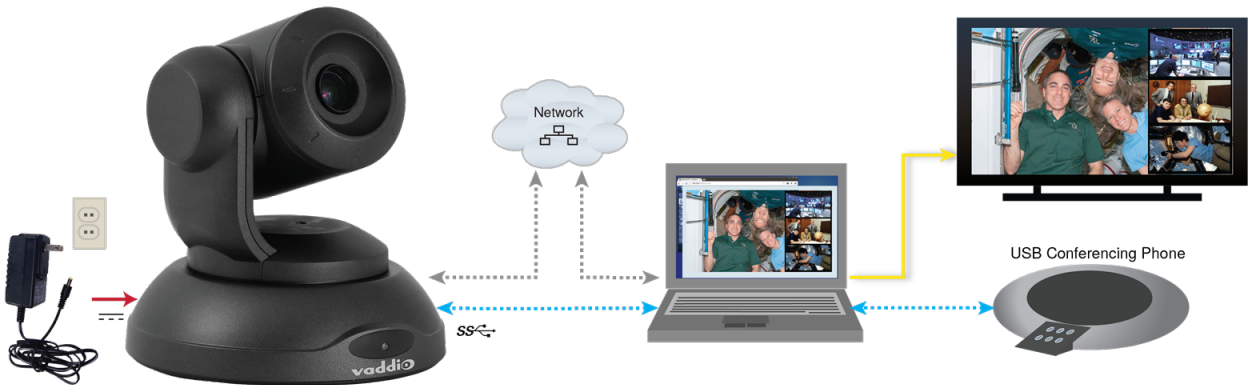

Installing the Camera

Caution

Before you start, be sure you can identify all cables correctly. Connecting a cable to the wrong port can result in equipment damage.

Caution

Check your cables. Connecting a cable to the wrong port or using the wrong pin-out can result in equipment damage and will void the warranty.

1. Verify that you have set the switches on the back of the camera to the desired settings.
2. Route the cables through the opening in the mounting shelf and connect them to the camera.

Caution:

Use the power supply shipped with the camera. Using a different power supply will damage the camera and void the warranty, and may create an unsafe operating condition.

3. Place the camera on the mount.

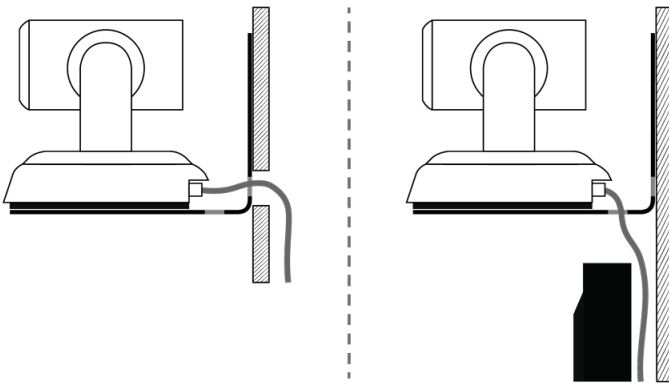

4. Attach the camera to the mount using the mounting screw supplied with the camera.

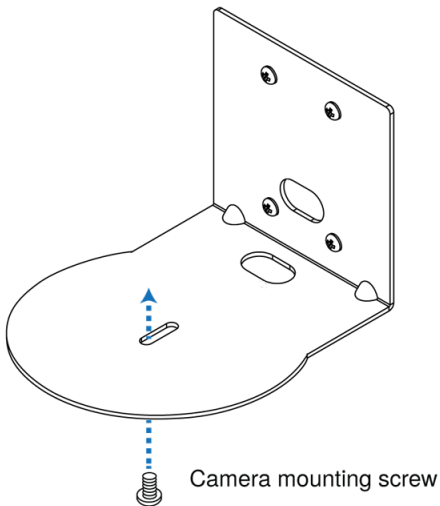

Image for illustration only; not to scale. Camera and mount details may differ.

Note

This is a fixed camera. After it is powered up and sending video, it will need to be positioned by hand.

Powering Up the Camera

Connect camera power. The status light illuminates purple as the camera initializes. When the camera is ready and a video stream is available, the light changes to blue.

Turn and tilt the camera as needed to position it for the desired view.

Next Steps

The camera is now ready to configure and use. This information is available in the **Complete Manual for the ConferenceSHOT FX USB 3.0 Fixed Camera**.

Operation, Storage, and Care

For smears or smudges on the product, wipe with a clean, soft cloth. Use a lens cleaner on the lens. Do not use any abrasive chemicals.

Keep this device away from food and liquids.

Do not operate or store the device under any of the following conditions:

- Temperatures above 40° C (104° F) or below 0° C (32° F)
- High humidity, condensing or wet environments
- Inclement weather
- Severe vibration
- On the hull of an orbital launch vehicle
- Dry environments with an excess of static discharge

Do not attempt to take this product apart. There are no user-serviceable components inside.

Compliance and Conformity Statements

Compliance testing was performed to the following regulations:

FCC Part 15 (15.107, 15.109), Subpart B	Class A
ICES-003, Issue 54: 2012	Class A
EMC Directive 2014/30/EU	Class A
EN 55032: 2015	Class A
EN 55024: November 2010	Class A
IEC 60950-1:2005 (2nd Edition); Am 1: 2009 + Am 2: 2013	Safety
EN 60950-1: 2006 + A11: 2009 + A1: 2010 + A12: 2011 + A2: 2013	Safety

FCC Part 15 Compliance

This equipment has been tested and found to comply with the limits for a Class A digital device, pursuant to Part 15, Subpart B, of the FCC Rules. These limits are designed to provide reasonable protection against harmful interference when the equipment is operated in a commercial environment. This equipment generates, uses, and can radiate radio frequency energy and, if not installed and used in accordance with the instruction manual, may cause harmful interference to radio communications. Operation of this equipment in a residential area is likely to cause harmful interference in which case the user will be required to correct the interference at his/her own expense.

Operation is subject to the following two conditions: (1) This device may not cause interference, and (2) This device must accept any interference including interference that may cause undesired operation of the device.



Changes or modifications not expressly approved by Vaddio can affect emission compliance and could void the user's authority to operate this equipment.

ICES-003 Compliance

This digital apparatus does not exceed the Class A limits for radio noise emissions from digital apparatus set out in the Radio Interference Regulations of the Canadian Department of Communications.

Le présent appareil numérique n'émet pas de bruits radioélectriques dépassant les limites applicables aux appareils numériques de la classe A prescrites dans le Règlement sur le brouillage radioélectrique édicté par le ministère des Communications du Canada.



European Compliance

This product has been evaluated for Electromagnetic Compatibility under the EMC Directive for Emissions and Immunity and meets the requirements for a Class A digital device. In a domestic environment this product may cause radio interference in which case the user may be required to take adequate measures.

Standard(s) To Which Conformity Is Declared:



EMC Directive 2014/30/EU

EN 55032: 2015 – Conducted and Radiated Emissions

EN 55024: November 2010 – Immunity

IEC 60950-1: 2005 (2nd Edition); Am 1: 2009 + Am 2: 2013 – Safety

EN 60950-1: 2006 + A11: 2009 + A1: 2010 + A12: 2011 + A2: 2013 – Safety

IEC 62368-1: 2014 (2nd Edition) – Safety

Photo Credits

This guide may include some or all of these photos.

European Space Agency (ESA) astronaut Samantha Cristoforetti, a Flight Engineer with Expedition 42, photographs the Earth through a window in the Cupola on the International Space Station

By NASA - https://blogs.nasa.gov/ISS_Science_Blog/2015/03/06/women-in-space-part-two-whats-gender-got-to-do-with-it/, Public Domain, <https://commons.wikimedia.org/w/index.php?curid=38834990>

Carl Sagan, Bruce Murray, Louis Friedman (founders) and Harry Ashmore (advisor), on the occasion of signing the papers formally incorporating The Planetary Society

By credit NASA JPL - JPL, Public Domain, <https://commons.wikimedia.org/w/index.php?curid=1180927>

Main Control Room / Mission Control Room of ESA at the European Space Operations Centre (ESOC) in Darmstadt, Germany

By European Space Agency - ESOC flickr, Credit: ESA - Jürgen Mai, CC BY-SA 3.0-igo,

<https://commons.wikimedia.org/w/index.php?curid=36743173>

Expedition 42 on orbit crew portrait, International Space Station, Mar. 7, 2015 – Barry Wilmore (Commander) Top, Upside down, to the right cosmonaut Elena Serova, & ESA European Space Agency Samantha Cristoforetti. Bottom center US astronaut Terry Virts, top left cosmonauts Alexander Samokutyaev and Anton Shkaplerov.

By NASA - <https://www.flickr.com/photos/nasa2explore/16166230844/>, Public Domain,

<https://commons.wikimedia.org/w/index.php?curid=38931301>

European Space Agency astronaut Luca Parmitano, Expedition 36 flight engineer, outside the International Space Station

By NASA - <http://spaceflight.nasa.gov/gallery/images/station/crew-36/html/iss036e016704.html>, Public Domain, <https://commons.wikimedia.org/w/index.php?curid=27263573>

Chris Cassidy, Luca Parmitano, and Karen Nyberg, ISS, 2013. Photo Credit: NASA

Nicolas Altobelli, Rosetta Scientist at ESA's European Space Astronomy Centre, Villanueva de la Cañada, Madrid, Spain

By European Space Agency - Nicolas Altobelli talks to the media, CC BY-SA 3.0-igo,

<https://commons.wikimedia.org/w/index.php?curid=36743144>

Andrea Accomazzo, ESA Rosetta Spacecraft Operations Manager, providing a live update from the Main Control Room at ESA's European Space Operations Centre, Darmstadt, Germany during the Rosetta wake-up day.

By European Space Agency - Live update from the Main Control Room, CC BY-SA 3.0-igo,

<https://commons.wikimedia.org/w/index.php?curid=36743150>

Sleeping goose

By ladypine - Own work, CC BY-SA 3.0, <https://commons.wikimedia.org/w/index.php?curid=1695227>

By Rick Dikeman - Image:Wayne Gretzky 1997.jpg, CC BY-SA 3.0,

<https://commons.wikimedia.org/w/index.php?curid=945698>

Photo AS11-40-5948, Aldrin assembles seismic experiment, by National Aeronautics and Space Administration, courtesy of the NASA History Office and the NASA JSC Media Services Center

Index

A

anatomy of the camera 3-4

C

cable connectors 6
camera ID setting (DIP switch) 8
camera mount 2, 5, 10-11
camera placement 5
camera select See also camera ID setting (DIP switch)
capabilities 1
ceiling-mounted cameras 8
cleaning 13
color codes for status light 8
connection diagram 10
connector pin-out, RS-232 9

D

damage, preventing 2, 5-6, 9
diagram, connection 10
DIP switches 4, 8
 location 4
 settings 8

I

image flip setting (DIP switch) 8
indicator light 8
 meaning of colors 8
installation 10-11
 basic connections 10
 camera 11
 camera mount 10
inverted installation 8

L

light, status indicator 8
 meaning of colors 8
location of the camera 5

M

mount 5, 10-11
mounting the camera 5, 11

O

operating environment 5, 13

P

packing list 2
part numbers 2
pin-out, RS-232 connector 9
power supply 2
precautions 2, 5
 for operating the system 5
product capabilities 1

R

requirements 5
 installation 5
 mounting 5
RJ-45 connectors 6
RS-232 communication settings 9
RS-232 connector pin-out 9
RS-232 serial connection 9

S

shelf-mounted cameras 11
shelf, camera mount 10
site requirements 5
status light 8
 meanings of colors 8
storage environment 13
switch location 4
switch settings 8
 camera ID (DIP switch) 8
 image flip (DIP switch) 8

T

temperature, operating and storage 13
third-party control 9

U

USB cable 2

V

visual parts identification 3

W

wall mount 10
warranty 5

Vaddio is a brand of Legrand AV Inc. · www.legrandav.com · Phone 800.572.2011 / +1.763.971.4400 · Fax +1.763.971.4464 · Email av.vaddio.support@legrand.com

Visit us at www.legrandav.com for firmware updates, specifications, drawings, manuals, technical support information, and more.

©2020 Legrand AV Inc.

Vaddio is a registered trademark of Legrand AV Inc. All other brand names or marks are used for identification purposes and are trademarks of their respective owners. All patents are protected under existing designations. Other patents pending.

A brand of  legrand®

Commercial AV Brands Chief | Da-Lite | Middle Atlantic | Projecta | Vaddio

vaddio®