

# PREMIUM+ PDU WITH RACKLINK™

MONITOR | CONTROL | ALERT | REPORT | ANALYZE

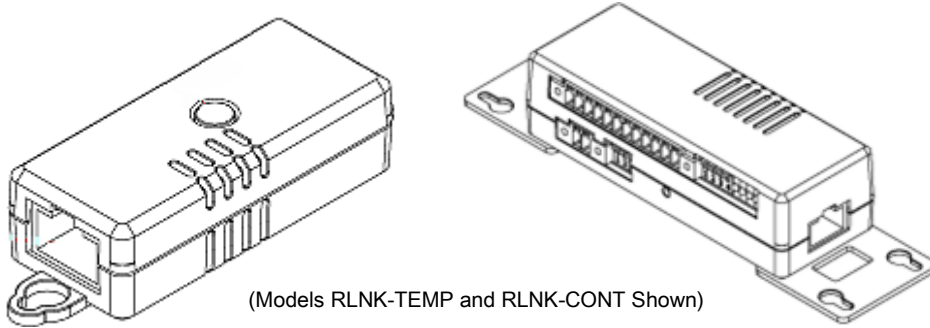

(Models RLNK-TEMP and RLNK-CONT Shown)

## THANK YOU

Thank you for purchasing an environmental sensor that is part of the Premium+ PDU with RackLink™ product line. Please read these instructions thoroughly before installing or assembling this product.



**Middle Atlantic Products**

I-00853

Rev B

# Contents

---

## Chapter 1: Introduction 7

---

|                         |   |
|-------------------------|---|
| Sensor Overview.....    | 7 |
| Sensor Comparison ..... | 8 |

---

## Chapter 2: Temperature and Humidity Sensor Series 9

---

|   |    |
|---|----|
| Temperature and Humidity Sensor Package.....            | 9  |
| Temperature and Humidity LED States.....                | 10 |
| Making Connections .....                                | 10 |
| Cascading Temperature and Humidity Sensor Packages..... | 10 |

---

## Chapter 3: Contact Closure Sensor Series 12

---

|  |    |
|--|----|
| Contact Closure Sensor Package.....                  | 12 |
| RLNK-CONT Terminals Dip Switches, and LEDs .....     | 13 |
| Making Connections .....                             | 15 |
| Pre-installed RLNK-CONT Brackets.....                | 15 |
| Connecting Detectors/Dry Contacts to RLNK-CONT ..... | 15 |
| Cascading RLNK-CONT Sensor Packages .....            | 17 |
| Adjusting Dip Switches .....                         | 18 |

---

## Chapter 4: Sensor-Mixing Connections 19

---

|  |    |
|--|----|
| Cascading RLNK-TEMP and RLNK-CONT Sensor Packages..... | 19 |
|--|----|

---

## Appendix A: Supported Maximum Sensor Distance 19

---

---

## Appendix B: Supported Maximum Number of Sensors and Dry Contacts 19

---

---

## Appendix C: Sensor Firmware Update 20

---

---

## Appendix D: Sensor Naming Conventions 21

---

# IMPORTANT SAFETY INSTRUCTIONS

- Read these instructions.
- Keep these instructions.
- Heed all warnings.
- Follow all instructions.
- Clean only with dry cloth.
- Only use attachments/accessories specified by the



**DANGER HAZARDOUS VOLTAGE:** The lightning flash with the arrowhead symbol, within an equilateral triangle is intended to alert the user to the presence of uninsulated dangerous voltage within the product's enclosure that may be of sufficient magnitude to constitute a risk of electric shock to persons.



**WARNING:** A warning alerts you to a situation that could result in serious personal injury or death.



**CAUTION:** A caution alerts you to a situation that may result in minor personal injury or damage to the product and/or property.



**NOTE:** A note is used to highlight procedures pertaining to the installation, operation, or maintenance of the product.



**DANGER HAZARDOUS VOLTAGE:** To reduce the risk of electrical shock: Always unplug this device from the electrical outlet before cleaning.



**WARNING:** Failure to read, understand and follow the following information can result in serious personal injury, damage to the equipment or voiding of the warranty. It is the responsibility of the Installer/User to ensure that this product is loaded according to specifications.



**WARNING:** Risk of Electric Shock: Connect the device to a properly grounded outlet only. Do not defeat the safety purpose of the polarized or grounding-type plug. A polarized plug has two blades with one wider than the other. A grounding type plug has two blades and a third grounding prong. The wide blade or the third prong is provided for your safety. If the provided plug does not fit into your outlet, consult an electrician for replacement of the obsolete outlet.



**WARNING:** The apparatus shall not be exposed to dripping or splashing and that no objects filled with liquids, such as vases, shall be placed on the apparatus.



**WARNING:** To reduce the risk of burns, fire, electric shock, or injury to persons:

- Unplug from outlet before putting on or taking off parts.
- Close supervision is necessary when this device is used by, or near children, invalids, or disabled persons.
- Use this device only for its intended use as described in these instructions. Do not use attachments not recommended by the manufacturer.
- Never operate the device if it has a damaged cord or plug, if it is not working properly, if it has been dropped or damaged, or dropped into water. Return the device to a service center for examination and repair.
- Protect the power cord from being walked on or pinched particularly at plugs, convenience receptacles, and the point where they exit from the apparatus.
- Keep the cord away from heated surfaces.
- Never drop or insert any object into any opening.
- Do not use outdoors.
- Do not operate where aerosol (spray) products are being used or where oxygen is being administered.
- To disconnect, turn all controls to the off position, then remove plug from outlet.



**CAUTION:** The socket-outlet shall be installed near the equipment and shall be easily accessible.



**CAUTION:** Use indoor in dry locations only.

## Safety Instructions: Rack Mount

**Elevated Operating Ambient:** If installed in a closed or multi-unit rack assembly, the operating ambient temperature of the rack environment may be greater than room ambient. Therefore, consideration should be given to installing the equipment in an environment compatible with the maximum ambient temperature (T<sub>ma</sub>) specified by the manufacturer.

**Reduced Air Flow:** Installation of the equipment in a rack should be such that the amount of air flow required for safe operation of the equipment is not compromised.

**Mechanical Loading:** Mounting of the equipment in the rack should be such that a hazardous condition is not achieved due to uneven mechanical loading.

**Circuit Overloading:** Consideration should be given to the connection of the equipment to the supply circuit and the effect that overloading of the circuit might have on overcurrent protection and supply wiring. Appropriate consideration of equipment nameplate ratings should be used when addressing this concern.

**Reliable Earthing:** Reliable earthing of rack-mounting equipment should be maintained. Particular attention should be given to supply connections other than direct connections to the branch circuit (e.g. use of power strips).

**Disconnect Device (Pluggable Equipment):** The socket-outlet shall be installed near the equipment and shall be easily accessible.

When using electrical products, basic precautions should always be followed, including the following:

- Read and follow all instructions before using.
- There are no user-serviceable components within this device. Removal of the cover from this device may present a shock hazard, and void the warranty.
- The mains plug is used as your disconnect device. This device shall remain readily operable.
- Unplug this apparatus during lightning storms or when unused for long periods of time.
- Do not overload the wall outlet where this device is being connected. Do not overload this device. Ensure the total load to this device does not exceed that which is listed in the specifications section of this manual.
- Ensure this device is connected to a properly grounded AC power source. Ensure the device is plugged into a source providing the required 120V. Do not use a plug adapter that defeats the ground pin of the AC plug.

## REGULATORY COMPLIANCE

### *Federal Communications Commission (FCC) Compliance Statement*



**CAUTION:** Any changes or modifications not expressly approved by the party responsible for compliance could void the user's authority to operate the equipment.

**NOTE:** This equipment has been tested and found to comply with the limits for a Class B digital device, pursuant to part 15 of the FCC Rules. These limits are designed to provide reasonable protection against harmful interference in a residential installation. This equipment generates, uses and can radiate radio frequency energy and, if not installed and used in accordance with the instructions, may cause harmful interference to radio communications. However, there is no guarantee that interference will not occur in a particular installation. If this equipment does cause harmful interference to radio or television reception, which can be determined by turning the equipment off and on, the user is encouraged to try to correct the interference by one or more of the following measures:

- Reorient or relocate the receiving antenna.
- Increase the separation between the equipment and receiver.
- Connect the equipment into an outlet on a circuit different from that to which the receiver is connected.
- Consult the dealer or an experienced radio/TV technician for help.

### *Industry Canada (IC)*

ICES-003 Class B Notice. This Class B digital apparatus complies with Canadian ICES-003.

# INSTRUCTIONS IMPORTANTES SUR LA SÉCURITÉ

- Lire ces instructions.
- Respectez tous les avertissements.
- Nettoyer uniquement avec un chiffon sec.
- Conservez ces instructions.
- Suivez toutes les instructions.
- N'utilisez que des accessoires spécifiés par le fabricant.



**DANGER TENSION DANGEREUSE:** Le symbole de la pointe de flèche, dans un triangle équilatéral, est destiné à alerter l'utilisateur sur la présence de tension dangereuse non isolée dans l'enceinte du produit qui peut être d'une ampleur suffisante pour constituer un risque d'électrocution.



**AVERTISSEMENT:** Un avertissement vous avertit d'une situation pouvant entraîner des blessures graves ou la mort.



**ATTENTION:** Une attention vous avertit d'une situation pouvant entraîner des blessures mineures ou des dommages au produit et/ou à la propriété.

**REMARQUE:** Une remarque est utilisée pour mettre en évidence les procédures relatives à l'installation, au fonctionnement ou à l'entretien du produit.



**DANGER TENSION DANGEREUSE:** Pour réduire le risque de choc électrique: Toujours débrancher le meuble de la prise électrique avant de le nettoyer.



**AVERTISSEMENT:** Ne pas lire, comprendre et suivre les informations suivantes peut entraîner des blessures graves, des dommages à l'équipement ou de la nullité de la garantie. Il incombe à l'installateur/utilisateur de s'assurer que ce produit est chargé conformément aux spécifications.



**AVERTISSEMENT:** Risque de choc électrique: Brancher le meuble uniquement à une prise correctement mise à la terre. Ne pas détériorer le dispositif de sécurité de la fiche polarisée ou de la fiche de terre. Une fiche polarisée possède deux broches, dont l'une plus large que l'autre. Une fiche de type terre possède deux broches et une troisième de mise à la terre. La broche large ou la troisième broche sont fournies pour des raisons de sécurité. Si la fiche fournie n'entre pas dans votre prise de courant, veuillez faire appel à un électricien pour remplacer la prise obsolète.



**AVERTISSEMENT:** L'appareil ne doit pas être exposé à des éclaboussures et aucun objet rempli de liquide, comme des vases, ne doit être placé sur l'appareil.



**AVERTISSEMENT:** Pour réduire les risques de brûlures, d'incendie, de choc électrique ou de blessures:

- Débrancher de la prise électrique avant d'installer ou de retirer des pièces.
- Surveiller étroitement ce meuble s'il est utilisé par ou à proximité d'un enfant, d'une personne invalide ou handicapée.
- N'utiliser ce meuble que pour l'usage auquel il est destiné, tel que décrit dans la présente fiche d'instructions. Ne pas utiliser d'accessoires non recommandés par le fabricant.
- Ne jamais utiliser ce meuble si le cordon ou la prise est endommagé, s'il ne fonctionne pas correctement, s'il est tombé ou est endommagé, ou s'il est tombé dans l'eau. Renvoyer le meuble à un centre de service après-vente pour qu'il soit examiné et réparé.
- Le cordon d'alimentation doit être placé de manière à éviter qu'il soit piétiné ou pincé, notamment au niveau des prises, des réceptacles et à la sortie de l'appareil.
- Garder le cordon d'alimentation loin des surfaces chauffées.
- Ne jamais faire tomber ou introduire un objet dans une ouverture.
- Ne pas utiliser en extérieur.
- Ne pas utiliser dans des lieux où des produits aérosols sont utilisés ou à proximité d'une source d'oxygène.
- Pour débrancher, placer tous les boutons en position off, puis retirer la fiche de la prise électrique.



**ATTENTION:** La prise de courant doit être installée près de l'équipement et doit être facilement accessible.



**ATTENTION:** Pour être utilisé en intérieur dans un endroit sec seulement.

**Consignes de sécurité:** montage en rack

**Température de fonctionnement:** Si installé dans un rack fermé ou à unités multiples, la température ambiante de fonctionnement de l'environnement du rack peut être supérieure à ambiante de la pièce. Par conséquent, il faudrait envisager d'installer l'équipement dans un environnement compatible avec la température ambiante maximale (T<sub>ma</sub>) spécifiée par le constructeur.

**Réduction Air accréditives:** Installation de l'équipement dans un rack doit être telle que la quantité de flux d'air nécessaire au bon fonctionnement de l'équipement ne soit pas compromise.

**Chargement mécanique:** Le montage de l'équipement dans le rack doit être telle qu'une condition dangereuse ne lié à un chargement mécanique irrégulier.

**Surcharge des circuits:** Il faudrait envisager à la connexion de l'équipement au circuit d'alimentation et l'effet que la surcharge du circuit pourrait avoir sur la protection contre les surintensités et le câblage d'alimentation. Examen approprié des équipements évaluations de la plaque signalétique doit être utilisée pour traiter de cette préoccupation.

**Mise à la terre fiable:** Fiable mise à la terre de l'équipement de montage en rack doit être maintenue. Une attention particulière devrait être accordée aux connexions d'alimentation autres que les connexions directes vers le circuit de dérivation (par exemple de l'utilisation de bandes de puissance).

**Appareil Disconnect (Équipement Pluggable):** La prise de courant doit être installée à proximité du matériel et doit être facilement accessible.

Lors de l'utilisation des produits électriques, des précautions de base doivent toujours être respectées, y compris les suivantes:

- Lire et suivre toutes les instructions avant l'utilisation du matériel.
- Il n'ya pas de composants réparables par l'utilisateur au sein de cet appareil. Retrait de la couverture de cet appareil peut présenter un danger d'électrocution et annuler la garantie.
- La fiche secteur est utilisée comme sectionneur de courant. Ce dispositif doit rester en état de marche.
- Débrancher cet appareil pendant les orages ou s'il n'est pas utilisé pendant de longues périodes.
- Ne surchargez pas le réceptacle de mur ou le circuit qui fournit l'énergie à ce appareil. Ne pas surcharger cette appareil. S'assurer que la charge totale à cet appareil ne dépasse pas celle qui est répertoriée dans la section des spécifications de ce manuel.
- Assurez-vous cet appareil est connecté à une source d'alimentation C/A avec mise à la terre. Assurez-vous cet appareil est branché sur une source d'alimentation fournissant les nécessaires 120V. Ne pas utiliser un adaptateur qui contrecarre la broche de terre de la prise du cordon d'alimentation.

## CONFORMITÉ RÉGLEMENTAIRE

### *Déclaration de conformité de la Federal Communications Commission (FCC)*



**ATTENTION:** Les changements ou modifications non expressément approuvés par le fabricant peuvent annuler le droit de l'utilisateur à utiliser l'équipement.

**REMARQUE:** Cet équipement a été testé et jugé conforme aux limites d'un dispositif numérique de classe B, conformément à la partie 15 des règles de la FCC. Ces limites sont conçues pour fournir une protection raisonnable contre les interférences nuisibles dans une installation résidentielle. Cet équipement génère, utilise et peut émettre de l'énergie radiofréquence et, si non installé et utilisé conformément aux instructions, peut provoquer des interférences dans les communications radio. Cependant, il n'y a aucune garantie que des interférences ne se produiront pas dans une installation particulière. Si cet équipement provoque des interférences nuisibles à la réception radio ou de télévision, ce qui peut être déterminé en allumant et éteignant l'équipement, l'utilisateur est encouragé à essayer de corriger l'interférence par une ou plusieurs des mesures suivantes:

- Réorienter ou déplacer l'antenne de réception.
- Augmenter La distance entre l'équipement et le récepteur.
- Brancher l'équipement dans une prise sur un circuit différent de celui sur lequel est branché le récepteur.
- Consulter le revendeur ou un technicien radio/TV expérimenté.

### *Industrie Canada (IC)*

ICES-003 Avis NMB-003, Classe B. Cet appareil numérique de la classe B est conforme à la norme NMB-003 du Canada.

# Chapter 1: Introduction

Thank you for purchasing Middle Atlantic Products Premium+ PDU with RackLink (referred to in this document as PDU) Temperature and Humidity Sensor (RLNK-TEMP) and/or Contact Closure Sensor (RLNK-CONT).

The complete set of instructions for your PDU is available from [www.middleatlantic.com/resources/power-downloads.aspx](http://www.middleatlantic.com/resources/power-downloads.aspx) and includes the following documents:

- The Quick Start Guide (I-00827 for Rackmount Units, I-00864 for Compact Units)
- The User Manual (I-00826) includes information about the WiFi Sensor.
- The Advanced User Manual (I-00852)
- The Environmental Sensors User Manual (I-00853)

---

## Sensor Overview

The RLNK-TEMP sensor is used to detect the environmental condition, such as temperature and humidity. The RLNK-CONT dry contact is used to control a system or mechanism, such as turning on or off a device.

Depending on the firmware of your PDU, there is a maximum number of sensors or dry contacts supported by your PDU. See *Appendix B: Supported Maximum Number of Sensors and Dry Contacts* (on page 19).

The maximum cabling length for sensor packages connected to a product's sensor port should not exceed 98 feet (30 meters). For the supported cabling length, see *Appendix A: Supported Maximum Sensor Distance* (on page 19).



**WARNING:** For proper operation, wait for 15~30 seconds between each connection operation or each disconnection operation of environmental sensor packages.

**AVERTISSEMENT:** Pour un fonctionnement correct, attendez 15 à 30 secondes entre chaque opération de connexion ou chaque opération de déconnexion des boîtiers de capteurs environnementaux.

## Sensor Comparison

| Sensor family                        | Connection interface | Support for sensor series connected | Chain position availability* | Automatic sensor firmware update |
|--------------------------------------|----------------------|-------------------------------------|------------------------------|----------------------------------|
| Temperature and Humidity (RLNK-TEMP) | RJ-45                | ✔                                   | ✔                            | ✔                                |
| Contact Closure (RLNK-CONT)          | RJ-45                | ✔                                   | ✔                            | ✔                                |

\* Chain position availability column indicates whether a sensor's position in a sensor series connection is available or not. This information can be retrieved through the PDU's web interface. For more information, refer to *Peripherals* in the Premium+ PDU With RackLink User Manual at [www.middleatlantic.com/resources/power-downloads.aspx](http://www.middleatlantic.com/resources/power-downloads.aspx)



## Chapter 2: Temperature and Humidity Sensor Series

### Temperature and Humidity Sensor Package

The Temperature and Humidity sensor package (RLNK-TEMP) features the following:

- An RJ-45 connection interface.
- You can cascade a maximum of 12 Temperature and Humidity sensor packages.

A standard network patch cable (CAT5e or higher) is needed to:

- Connect a Temperature and Humidity sensor to a PDU with the RJ-45 SENSOR port.
- Series connect Temperature and Humidity sensor packages.

*Warning: Do NOT use a crossover cable for connection.*

| Sensor package | Description   |
|----------------|---|
| RLNK-TEMP      | <ul style="list-style-type: none"> <li>• temperature sensor</li> <li>• humidity sensor</li> </ul> |

RLNK-TEMP is used to detect the environmental temperature and humidity.

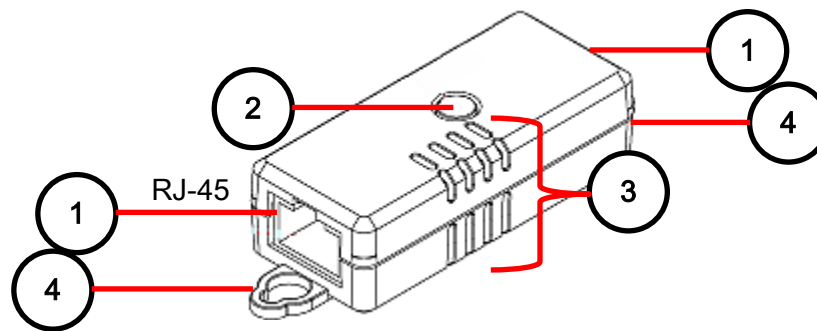

| Number | Component       | Function   |
|--------|-----------------|--|
| ①      | Two RJ-45 ports | <ul style="list-style-type: none"> <li>▪ Sensor connection to a product.</li> <li>▪ For series connecting Temperature and Humidity sensor packages.</li> </ul> |
| ②      | LED             | Indicates the sensor status. See <i>Temperature and Humidity LED States</i> (on page 10).  |
| ③      | Sensor Openings | Temperature probe opening. Do not block openings.  |
| ④      | Brackets        | Two brackets are installed on the rear side of the sensor for affixing it onto an object or into a position.   |

## Temperature and Humidity LED States

The Temperature and Humidity sensor indicates an alert by making its LED flash on and off. The LED also flashes when the sensor is upgrading its firmware.

| LED states          |                     | Description   |
|---------------------|---------------------|---|
| Off                 |                     | Both temperature and humidity are in the normal state.  |
| Flashing            | 1 flash and 1 off   | Temperature enters an alarmed state: warning or critical.<br>Humidity is in the normal state. |
|                     | 2 flashes and 1 off | Temperature is in the normal state.<br>Humidity enters an alarmed state: warning or critical. |
|                     | 3 flashes and 1 off | Both temperature and humidity enter an alarmed state: warning or critical.                    |
| High-speed flashing |                     | Sensor firmware is being updated.   |

## Making Connections

### Cascading Temperature and Humidity Sensor Packages

To increase the number of connected Temperature and Humidity sensor packages per SENSOR port, you can cascade Temperature and Humidity sensors using standard network patch cables (CAT5e or higher). Up to 12 Temperature and Humidity sensor packages can be series connected.

*Tip: You can also make a sensor chain comprising Temperature and Humidity and Contact Closure sensor packages. See **Cascading RLNK-TEMP and RLNK-CONT Sensor Packages** (on page 19).*

#### ► To cascade Temperature and Humidity sensor packages:

1. Connect a standard network patch cable to either RJ-45 port of the first sensor package.
2. If you want to cascade Temperature and Humidity sensor packages, get an additional standard network patch cable (CAT5e or higher) and then:
  - a. Plug one end of the cable into the remaining RJ-45 port on the previous Temperature and Humidity sensor.
  - b. Plug the other end into either RJ-45 port on an additional Temperature and Humidity sensor.

Repeat the same steps to cascade more Temperature and Humidity sensor packages.

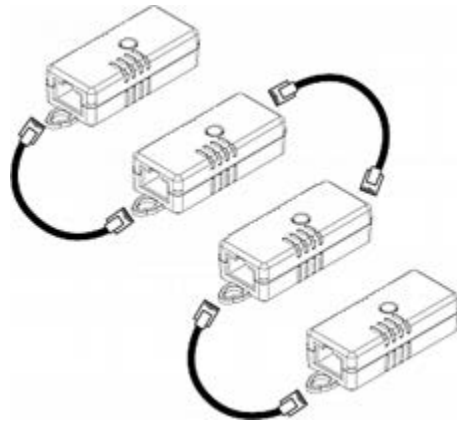

3. Make sure the total number of cascaded sensors does not exceed the maximum number of sensors supported per sensor port. See *Appendix B: Supported Maximum Number of Sensors and Dry Contacts* (on page 19).

## Chapter 3: Contact Closure Sensor Series

### Contact Closure Sensor Package

The Contact Closure sensor package (RLNK-CONT) consists of terminals, sensors and two RJ-45 ports.

A standard network patch cable (CAT5e or higher) is needed to:

- Connect a Contact Closure sensor to a PDU with the RJ-45 SENSOR port.
- Series connect Contact Closure sensor packages.

*Warning: Do NOT use a crossover cable for connection.*

The following table includes the available Contact Closure sensor package.

| Sensor packages | Description   |
|-----------------|---|
| RLNK-CONT       | <ul style="list-style-type: none"> <li>• (7) pairs of terminals:<br/>(2) for connections of dry contact signals (DC) and (5) for contact closure sensors (CC).</li> </ul> |

For detailed information on sensor names, see *Appendix D: Sensor Naming Conventions* (on page 21).

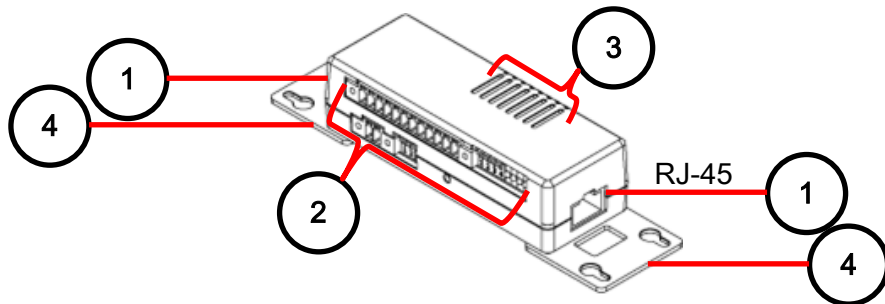

| Number | Component                         | Function  |
|--------|-----------------------------------|---|
| ①      | Two RJ-45 ports                   | <ul style="list-style-type: none"> <li>▪ Sensor connection to the product.</li> <li>▪ For series connecting Contact Closure sensor packages.</li> </ul> |
| ②      | Terminals, Dip Switches, and LEDs | See <i>RLNK-CONT Terminals Dip Switches, and LEDs</i> on page 13.   |
| ③      | Sensor Openings                   | Temperature probe opening. Do not block openings.   |

| Number | Component | Function   |
|--------|-----------|--|
| 4      | Brackets  | Two brackets are installed on the rear side of the sensor for affixing it onto an object or into a position. |

A label is attached to RLNK-CONT to help you identify different channels.

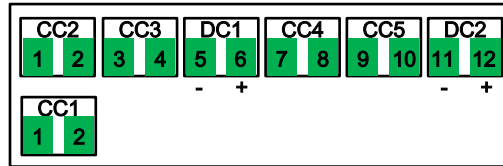



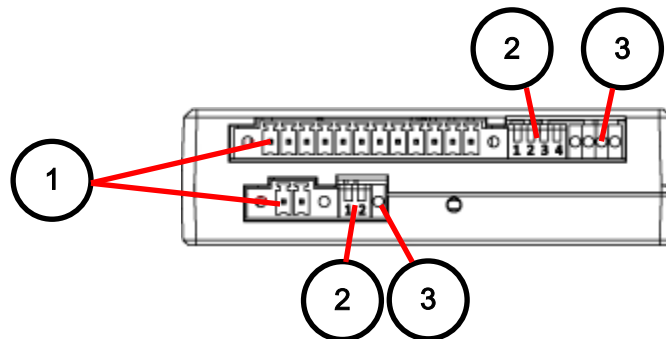

- CC represents a contact closure sensor channel. There are five CC channels: CC1 through CC5.
- DC represents a dry contact channel. There are two DC channels: DC1 and DC2.

### RLNK-CONT Terminals Dip Switches, and LEDs

Terminals, dip switches, and LEDs are separated into two rows as shown below.

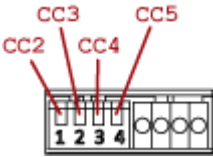

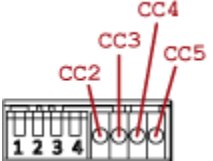
| Numbers | Components  |
|---------|---|
| 1       | <p>CC and DC channels.</p> <ul style="list-style-type: none"> <li>• <i>Top row:</i><br/>Four CC channels (CC2 - CC5).<br/>Two DC channels (DC1 - DC2).</li> <li>• <i>Bottom row:</i><br/>One CC channel (CC1).</li> </ul> <p>See <i>Connecting Detectors/Dry Contacts to RLNK-CONT</i> (on page 15) for how to connect CC sensors or DC dry contacts.</p> |

| Numbers  | Components   |
|----------|--|
| <p>2</p> | <p>Dip switches for configuring the Normal state of each CC channel. See <i>Adjusting Dip Switches</i> (on page 18).</p> <ul style="list-style-type: none"> <li> <p><i>Top row:</i></p> <p>Dip switch 1 controls CC2.</p> <p>Dip switch 2 controls CC3.</p> <p>Dip switch 3 controls CC4.</p> <p>Dip switch 4 controls CC5.</p>  </li> <li> <p><i>Bottom row:</i></p> <p>Dip switch 1 controls CC1.</p>  </li> </ul>                                    |
| <p>3</p> | <p>CC status green LEDs. High-speed flashing of CC1 LED indicates that a firmware upgrade is in progress. See <i>Appendix C: Sensor Firmware Update</i> (on page 20).</p> <ul style="list-style-type: none"> <li> <p><i>Top row:</i></p> <p>The four green LEDs, from left to right, indicate the states of CC2, CC3, CC4 and CC5 respectively.</p>  </li> <li> <p><i>Bottom row:</i></p> <p>The green LED indicates the CC1 state.</p>  </li> </ul> |

---

## Making Connections

---

### Pre-installed RLNK-CONT Brackets

To allow users to hang or affix a RLNK-CONT onto an object or position, two brackets have been installed on the rear side of a RLNK-CONT sensor package when shipped out of the factory.

Below is the diagram of a RLNK-CONT sensor package with two brackets installed.

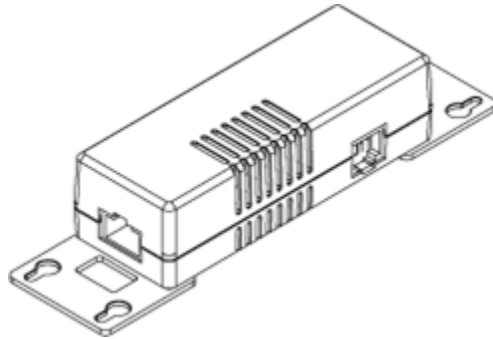

---

### Connecting Detectors/Dry Contacts to RLNK-CONT

A RLNK-CONT sensor package comprises two parts: a sensor box and the terminal module(s). A terminal module is removable.

*Note: The following diagrams illustrate a terminal module comprising two termination points only. Your RLNK-CONT terminal module may be larger if it has more terminals.*

---

### Making Connections When the Terminal Module is Attached

► **To make connections when the terminal module is attached:**

1. Strip the insulation around 12 mm from the end of each wire of a detector or dry contact.
  - Wire size range: AWG 28 to 20 or 0.09 to 0.5 mm<sup>2</sup>

2. Fully insert each wire into each termination point of a CC, or DC channel on the RLNK-CONT sensor package.

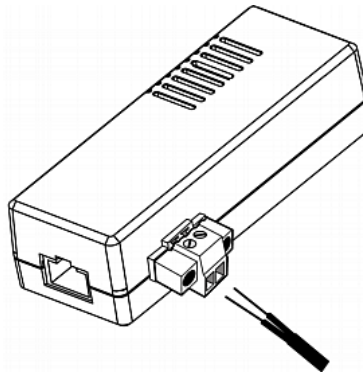

3. Use a screwdriver with a 2.5 mm wide shaft to tighten the screws above each termination point to secure the wires, using a torque of 0.196 N·m (2 kgf·cm).

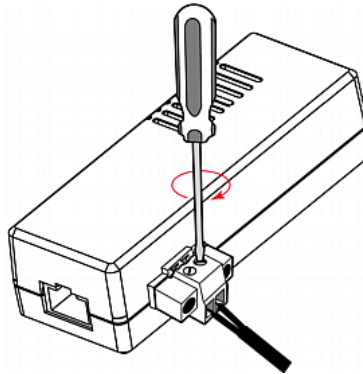

#### Making Connections After the Terminal Module is Detached

► To make connections after the terminal module is detached:

1. Loosen the screws at two sides of the terminal module.

---

*Note: The two screws are not removable so just loosen them.*

---

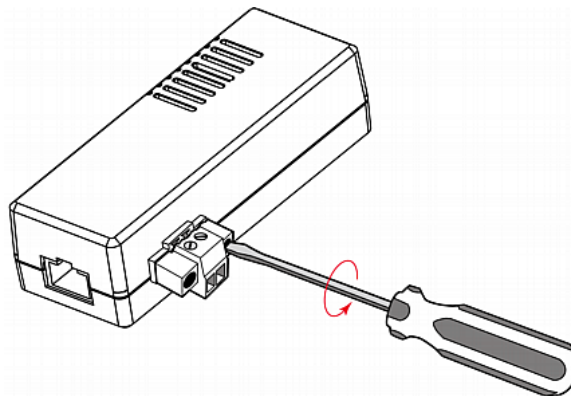



2. Separate the terminal module from the sensor box.

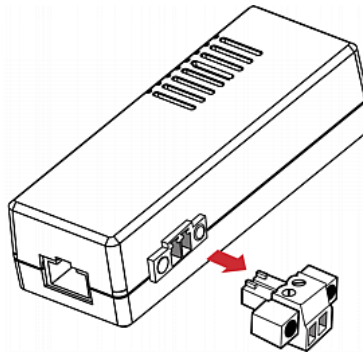

3. After connecting detectors/switches to the terminal module, plug the terminal module back into the sensor box, and then tighten the screws at two sides of the terminal module.

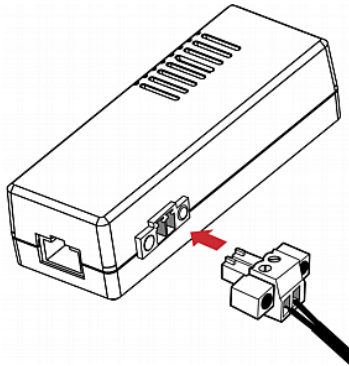

---

### Cascading RLNK-CONT Sensor Packages

To increase the number of connected RLNK-CONT sensor packages per SENSOR port, you can cascade RLNK-CONT using standard network patch cables (CAT5e or higher). A maximum of 12 RLNK-CONT sensor packages can be series connected.

*Warning: Do NOT use a crossover cable for connection.*

*Tip: You can also make a sensor chain comprising different sensor packages. See **Cascading RLNK-TEMP and RLNK-CONT Sensor Packages** (on page 19).*

---

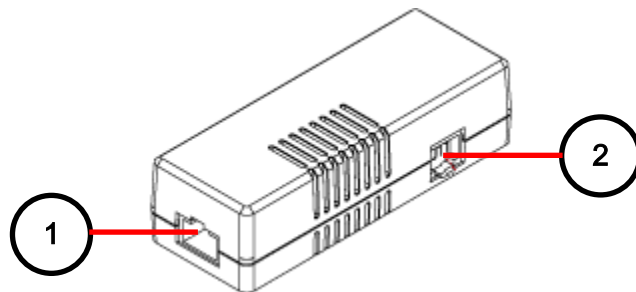

| Numbers | Components   |
|---------|--|
| ①       | RJ-45 ports, each of which is located on either end of a RLNK-CONT sensor package. |
| ②       | RJ-12 port, which is reserved for future use and is hidden now.                    |

► **To cascade RLNK-CONT sensor packages:**

1. Connect a standard network patch cable to either RJ-45 port of the first RLNK-CONT sensor package.
2. If you want to cascade RLNK-CONT packages, get an additional standard network patch cable (CAT5e or higher) and then:
  - a. Plug one end of the cable into the remaining RJ-45 port on the prior RLNK-CONT package.
  - b. Plug the other end into either RJ-45 port on an additional RLNK-CONT package.

Repeat the same steps to cascade more RLNK-CONT packages.

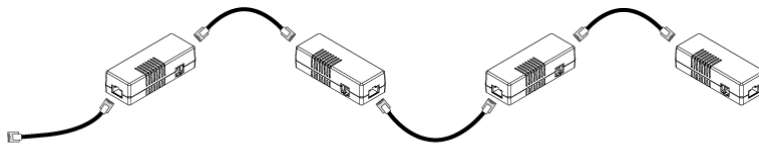

3. Verify that the total number of sensors and dry contacts connected to these RLNK-CONT packages does not exceed the maximum number of sensors and dry contacts supported per sensor port. See *Appendix B: Supported Maximum Number of Sensors and Dry Contacts* (on page 19).

---

## Adjusting Dip Switches

There are two Normal settings for each CC channel on DX packages.

- N.O (Normally Open): The open status of the connected detector/switch is considered normal.
- N.C (Normally Closed): The closed status of the connected detector/switch is considered normal.

Each CC channel is configured by turning on or off its corresponding dip switch.

► **To adjust dip switches for CC channels:**

- N.O: Turn ON the dip switch by pressing it down.
- N.C: Turn OFF the dip switch by pushing it up.

## Chapter 4: Sensor-Mixing Connections

This chapter shows how to mix different types of sensor packages on a sensor port. Other sensor-mixing connections than those shown in this chapter are NOT supported.

---

### Cascading RLNK-TEMP and RLNK-CONT Sensor Packages

You can mix RLNK-TEMP and RLNK-CONT in a sensor chain consisting of up to 12 sensor packages. The following diagram illustrates such a sensor-mixing chain.

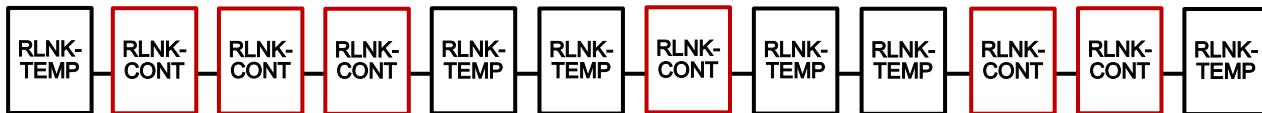

The series connection procedure is identical to the one described in the section titled *Cascading Temperature and Humidity Sensor Packages* (on page 10) or *Cascading RLNK-CONT Sensor Packages* (on page 17).

## Appendix A: Supported Maximum Sensor Distance

RLNK-TEMP and RLNK-CONT sensor packages support a total cabling length of up to 98 feet (30 m).

## Appendix B: Supported Maximum Number of Sensors and Dry Contacts

The PDU supports up to 32 sensor/dry contacts.

► **Calculation examples 32 sensors/dry contacts:**

A sensor package may contain more than one sensor/dry contact. A sensor or dry contact is a function. For example, a RLNK-CONT contains 8 functions because it has 6 sensors and 2 dry contacts.

- A PDU supports 32 managed sensors or dry contacts:

$$4 \times 8 = 32$$

Therefore, you can manage four RLNK-CONT packages per port.

► **Tip for RLNK-CONT sensor connection:**

If intended, you can connect a maximum of 12 RLNK-CONT sensor packages without exceeding the maximum number of sensors/dry contacts supported by your PDU. All you need to do is to manage "partial" sensors/dry contacts of each RLNK-CONT and unmanage the rest.

For example, your PDU can manage 32 sensors/dry contacts per port, you can connect 12 RLNK-CONT sensor packages to a sensor port by managing only two sensors or dry contacts of each RLNK-CONT.

$$12 * 2 = 24$$

All 24 sensors/dry contacts can be managed because it is less than 32.

For information on how to manage and unmanage any sensors/dry contacts, refer to the Premium+ PDU With RackLink User Manual at [www.middleatlantic.com/resources/power-downloads.aspx](http://www.middleatlantic.com/resources/power-downloads.aspx).

## Appendix C: Sensor Firmware Update

Sensor packages automatically upgrade or downgrade their firmware after being connected to a PDU that supports these sensor packages. This ensures that these sensor packages work properly with the connected PDU.

Automatic upgrade or downgrade is determined by comparing sensor firmware against the environmental sensor firmware stored inside the PDU. A downgrade can be performed only when the PDU-provided sensor firmware is either greater than or equal to the minimum firmware version requested by the connected sensor packages.

---

*Tip: Information regarding current sensor firmware version and the sensor's firmware update time is available in the Device Information dialog. Choose Maintenance > Device Information > Peripheral Devices in the web interface of your PDU.*

---

## Appendix D: Sensor Naming Conventions

The model name of an environmental sensor package consists of sensor family, sensor functions and the total number of the specified function.

[Family] - [Function\_1] [Number\_1]

- OR -

[Family] - [Function\_1] [Number\_1] [Function\_2] [Number\_2]

[Family] is RLNK-TEMP or RLNK-CONT.

[Number\_1] and [Number\_2] are integer numbers.

[Function\_1] and [Function\_2] are abbreviations representing diverse functions.

---

*Note: Some sensor packages may indicate only the main function instead of indicating all functions in its name.*

---

| Abbreviations | Functions                        |
|---------------|----------------------------------|
| CC or C       | Contact closure sensor terminals |
| D             | Dry contact signal terminals     |
| H             | Humidity sensors                 |
| T             | Temperature sensors              |

# WARRANTY

For warranty information, refer to <http://www.middleatlantic.com/company/about-us.aspx#warranty>.

## **Corporate Headquarters**

Voice: 973-839-1011 – Fax: 973-839-1976 – International Voice: +1 973-839-8821 –  
Fax: +1 973-839-4982 – [www.middleatlantic.com](http://www.middleatlantic.com) – [info@middleatlantic.com](mailto:info@middleatlantic.com)

## **Middle Atlantic Canada**

Voice: 613-836-2501 – Fax: 613-836-2690 – [ca.middleatlantic.com](http://ca.middleatlantic.com) – [customerservicecanada@middleatlantic.ca](mailto:customerservicecanada@middleatlantic.ca)

## **Middle Atlantic EMEA Technical Support**

Voice: +31 (0) 495 726002 - [av.emea.middleatlantic.support@legrand.com](mailto:av.emea.middleatlantic.support@legrand.com)

## **Factory Distribution**

United States: New Jersey, California, Illinois - Canada: Ontario - The Netherlands: Weert

**At Middle Atlantic Products we are always listening. Your comments are welcome.**

**Middle Atlantic Products is an ISO 9001 and ISO 14001 Registered Company.**