

ATOMIK

MODULAR POD

botton + gardiner
PUBLIC SPACE FURNITURE



About botton + gardiner

Botton + Gardiner is an Australian design and manufacturing company specialising in quality furniture and fixtures for public authorities, shopping centres, accommodation and hospitality industries. Established in 1995 and purchased by Baresque in 2013, Botton + Gardiner has successfully gained a significant position in domestic and export marketplaces for delivery of a high standard of product and service. Botton + Gardiner's range of Australian made products and offerings from overseas include urban furniture, banquette seating, litter receptacles and cafe and restaurant dining furniture for external and internal applications. Botton + Gardiner furniture can be found in shopping centres and council parklands as well as corporate breakout and meeting spaces. In hospitality, Botton + Gardiner products lend their distinctive character to five star hotels and restaurants designed by leading architects and interior designers.

Narellan Shopping Centre
Designed by botton + gardiner





botton + gardiner

PUBLIC SPACE FURNITURE

CONTENTS



OTTOMAN p16



TABLE p20



PLANTER p22



SCREEN p26



PLUTO GPO p32

PIXEL GPO p34



CONFIGURATION
IDEAS p36



FINISHES p44



ASSEMBLY INFO p56



INDEX p60



Atomik Design Features

Introducing Atomik, a collection of interacting Ottomans, Planters, Tables and Screens designed by Botton and Gardiner.

Atomik allows you to create flexible and versatile pods for use in shopping centres, hotels, office break out spaces, lobbies, universities and schools. Simplistic in form, the 13 geometric shapes give Atomik a dynamic, contemporary look whilst being super easy to arrange to meet your space requirements. Combine a mix of Atomik's Ottomans, Planters, Tables and Screens to provide small, private alcoves for quiet working spaces or relaxed communal seating for brainstorming and shared conversation. Atomik's shapes are available in our extensive range of standard finishes and colour palettes of durable and beautiful materials, delivering you virtually limitless combinations to best fit your next interior project.



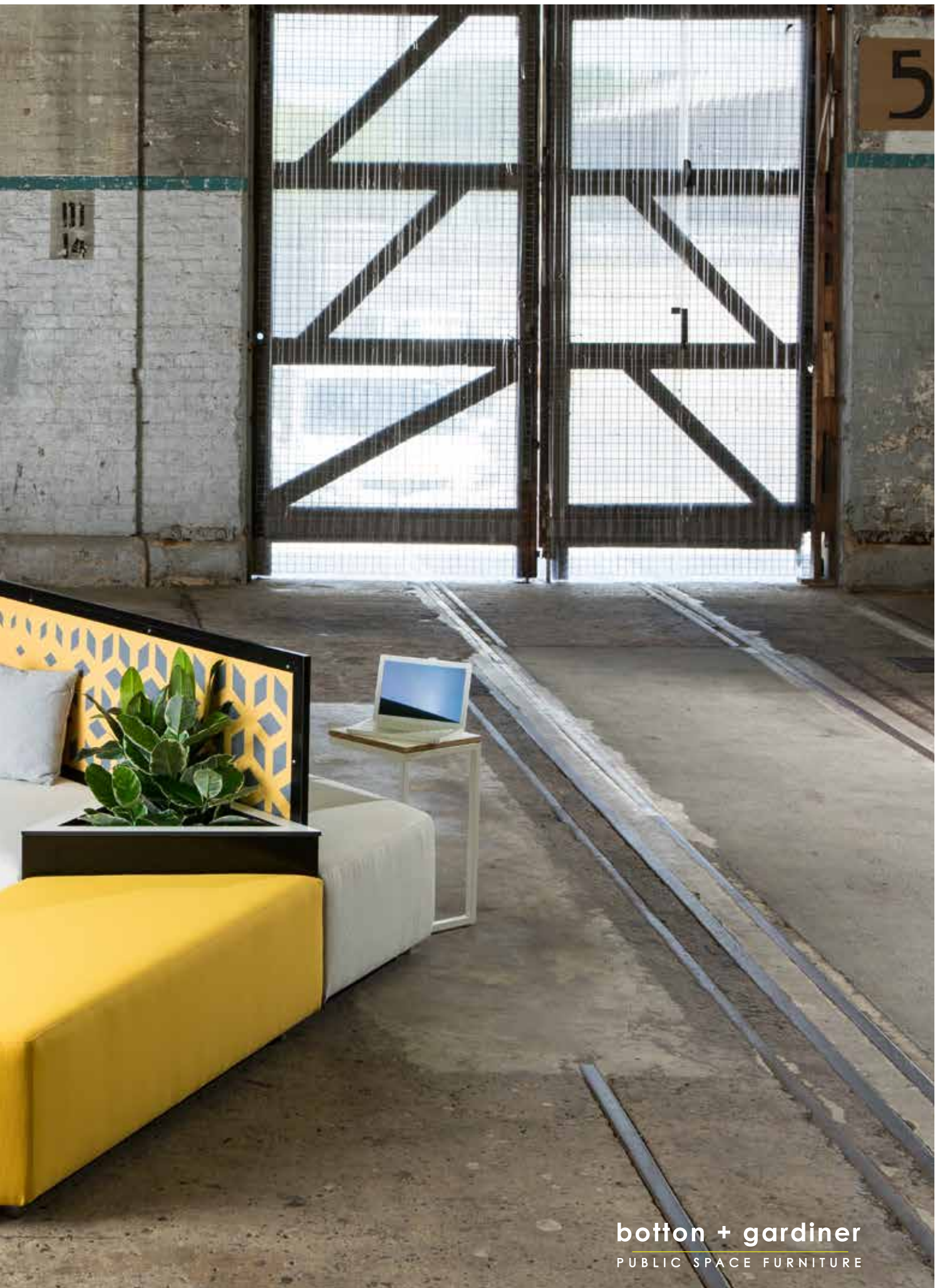

botton + gardiner
PUBLIC SPACE FURNITURE



For more amazing atomik configuration ideas see page 36-43
Product and finish selections for this configuration, see page 62-63





For more amazing atomik configuration ideas see page 36-43
Product and finish selections for this configuration, see page 62-63





For more amazing atomik configuration ideas see page 36-43
Product and finish selections for this configuration, see page 62-63





For more amazing atomik configuration ideas see page 36-43
Product and finish selections for this configuration, see page 62-63





OTTOMAN

Ottoman is ATOMIK's quintessential component and underpins the versatility and modularity of this new collection. Available in 8 different shapes plus an array of fabric choices, Ottoman offers unlimited custom seating solutions to suit every project brief.

FINISHES

Upholstery - custom fabric

Foam: high density, fire retardant foam with dacron

Internal frame - high moisture resistant board

OTTOMAN FABRIC

Select a fabric from the Baresque range, specify a custom fabric or supply your own

Fabric required (based on one plain colour/textured fabric, 137cm wide)

- O1 Rectangular ottoman: 3.5mtrs
- O2 Square ottoman: 1.8mtrs
- O3 Small moon ottoman: 1.8mtrs
- O4 Large moon ottoman: 3.5mtrs
- O5 Small trapezoid ottoman: 5.2mtrs
- O6 Large trapezoid ottoman: 3.5mtrs
- O7 Left parallelogram ottoman: 3.9mtrs
- O8 Right parallelogram ottoman: 3.9mtr

BACKREST FABRIC

- BR1 700mmL Short backrest: 0.8mtrs
- BR2 1400mmL Long backrest: 1.5mtrs
- BO1 700mmL Short bolster: 0.8mtrs
- BO2 1400mmL Long bolster: 1.5mtrs

FEATURES

8 different ottoman shapes and 2 backrest styles available to create your own custom configurations, refer to pages 36-43 for suggestions. Please note that the O3 Small moon shape is unable to be fitted with a backrest due to the shallower seat depth

WARRANTY

2 years, made in Australia

INDICATIVE LEADTIME

6 weeks depending on project size

ASSEMBLY

Items delivered in modules to site, some assembly required (by others) to connect modules together, see page 58 for details

Backrests are fixed to ottoman modules by Botton and Gardiner



OTTOMAN MODULES SIZES

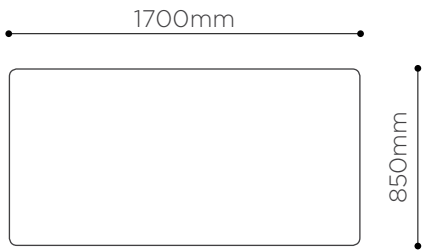

O1 RECTANGLE

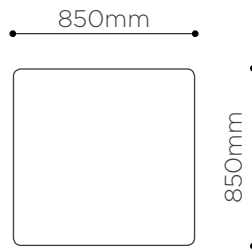

O2 SQUARE

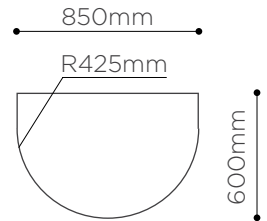

O3 SMALL MOON

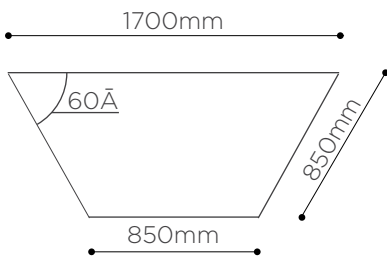

O5 SMALL TRAPEZOID

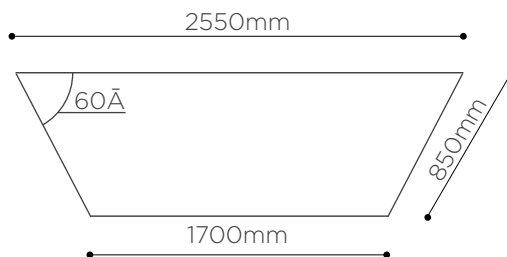

O6 LARGE TRAPEZOID

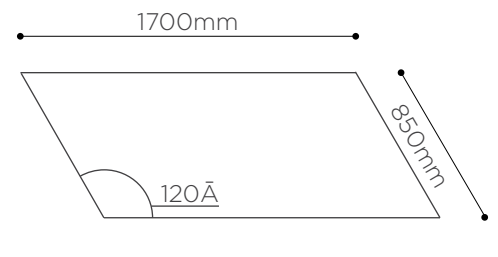

O7 LEFT PARALLELOGRAM

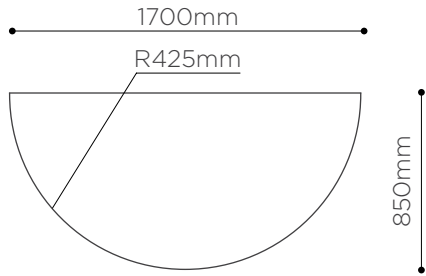

O4 LARGE MOON

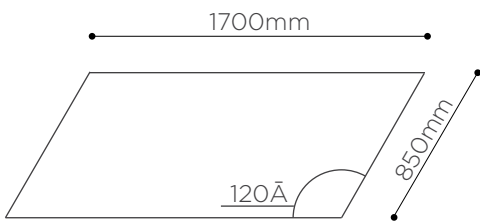

O8 RIGHT PARALLELOGRAM

BACKRESTS SIZES

To give extra support and comfort, add a backrest to any of the ottomans except the Small moon shape

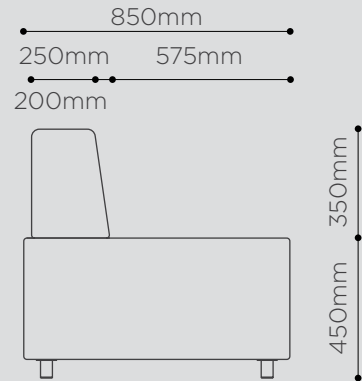

BACKREST

BR1 700MM LONG

BR2 1400MM LONG

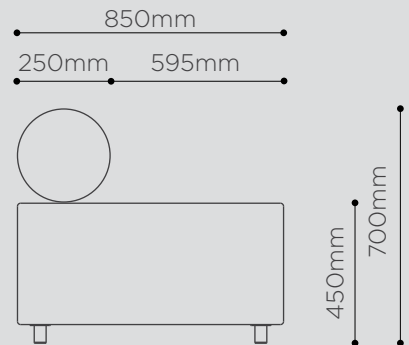

BOLSTER

BO1 700MM LONG

BO2 1400MM LONG



TABLE

Introducing Table, perfect for resting a coffee or placing a laptop to charge, Table allows you to extend the functionality of your seating pod by incorporating multiuse zones. Embracing minimalism and simplicity in design, Table comes in 5 different shapes and a variety of top finishes to suit your interior concept.

FINISHES

Body - Powdercoated Galvanised Steel, see page 50 for standard colour ranges
Top - Hardwood, Lightblocks Board, Engineered Stone, Corian, or Compact Laminate
See pages 46-52 for standard colour ranges.

FEATURES

5 different shapes available to create flexible modular configurations
Add GPO or USB outlets to form charging points and stations for customers (ideal when paired with faux plants)

GPO

Two standard styles of power or USB outlets available, see pages 32-35 for details

WARRANTY

2 years, made in Australia

INDICATIVE LEADTIME

6 weeks depending on project size

ASSEMBLY

Items delivered in modules to site, some assembly required (by others) to connect modules together, see page 58 for details

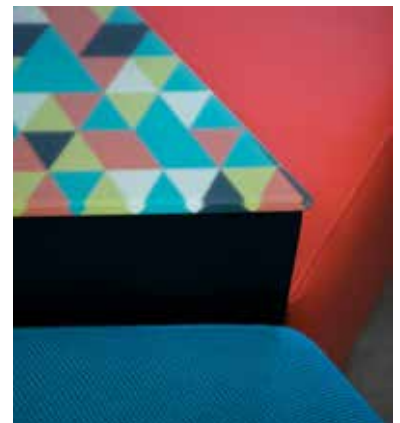



PLANTER

Bring the outside in by adding plants and greenery to your space. Plants will not only lift the ambience, but can help purify the air and assist with noise absorption. Our Planter component makes it easy to incorporate flora and foliage into your designs by seamlessly connecting with seating and table modules to make for flexible, functional settings. There are 5 Planter shapes available to suit your space.

FINISHES

Liner - 316 Stainless Steel

Body - Powdercoated Galvanised Steel, see page 50 for standard colour ranges.

Top - Hardwood, Lightblocks Board, Engineered Stone, Corian, or Compact Laminate.

See pages 46-52 for standard colour ranges.

FEATURES

316 marine Stainless Steel grade liner suitable for direct planting (optional galvanised steel liner available for faux plants)

5 different shapes available to create flexible modular configurations

Add GPO or USB outlets to form charging points and stations for customers (ideal when paired with faux plants)

GPO

Two standard styles of power or USB outlets available, see page 32-35 for details

WARRANTY

2 years, made in Australia

INDICATIVE LEADTIME

6 weeks depending on project size

ASSEMBLY

Items delivered in modules to site, some assembly required (by others) to connect modules together, see page 58 for details



TABLE MODULES SIZES

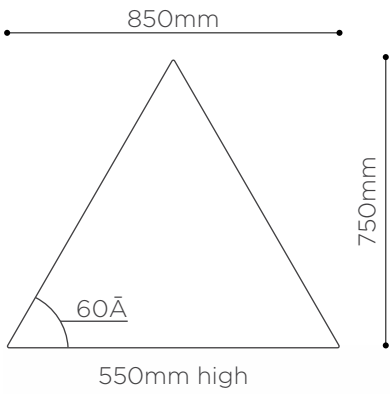

T1 EQUILATERAL TRIANGLE

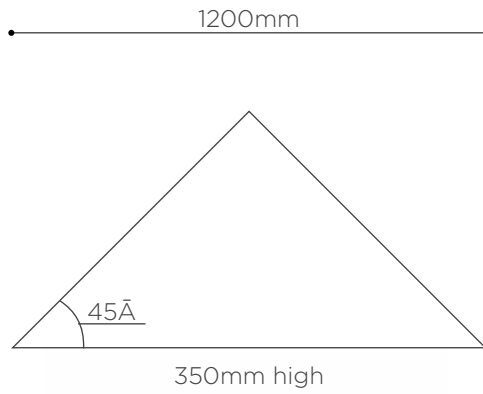

T2 RIGHT ANGLE TRIANGLE

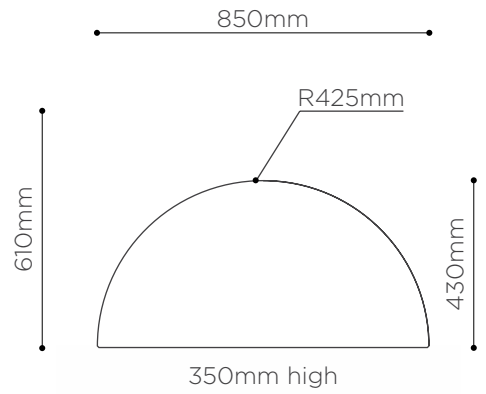

T3 SMALL MOON



T4 RECTANGLE

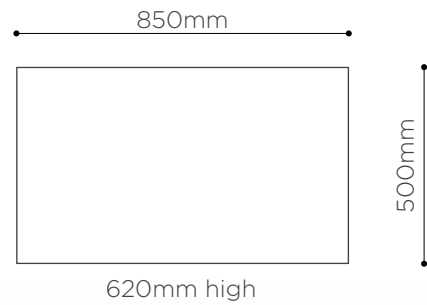

T5 LARGE RECTANGLE

PLANTER MODULES SIZES

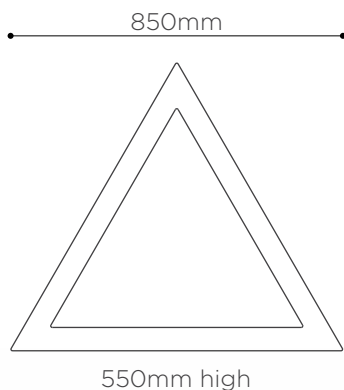

P1 EQUILATERAL TRIANGLE

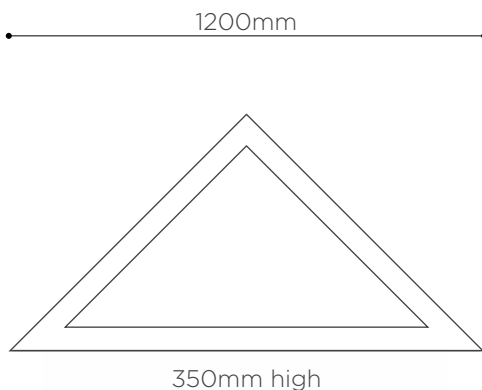

P2 RIGHT ANGLE TRIANGLE

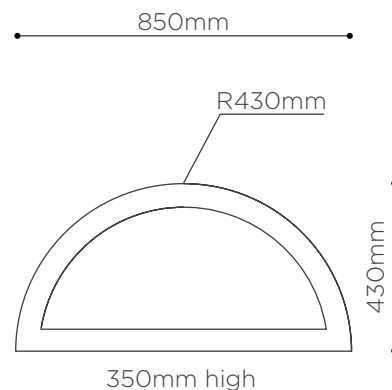

P3 SMALL MOON



P4 RECTANGLE

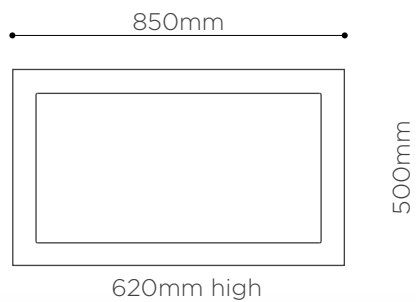

P5 LARGE RECTANGLE



SCREEN

Screen can deliver privacy as well as creating a textural focal point for ATOMIK. Available in 3 lengths, the variety of screen finishes allows incredible flexibility. Screen is available as solid, patterned or perforated and in an extensive range of finishes. Choose Zintra Acoustic if you need some sound absorption or create a stylish feature element or advertising panel with Seraphic Digital Print.

FINISHES

Frame - Powdercoated Steel, see page 50 for standard colour ranges

Panel - Zintra Acoustic Panel, Compact Laminate, Lightblocks Board with a ply, white or black core

See pages 49, 51-53 for standard colour ranges

FEATURES

3 lengths available to create flexible modular configurations

There are four standard patterns available if you want to perforate your screen panel - Asiatic, Shard, Setro or Perdita, see page 31

If you prefer a graphic or print applied to your screen we can digitally print on Zintra or Lightblocks panels, see page 53 for details

The panel can be customised to match your project finish, noting the specified material needs to be 12-18mm thick, call us to discuss your project requirements

WARRANTY

2 years, made in Australia

INDICATIVE LEADTIME

6 weeks depending on project size

ASSEMBLY

Items delivered in modules to site, some assembly required (by others) to connect modules together, see page 58 for details



SCREEN MODULES SIZES

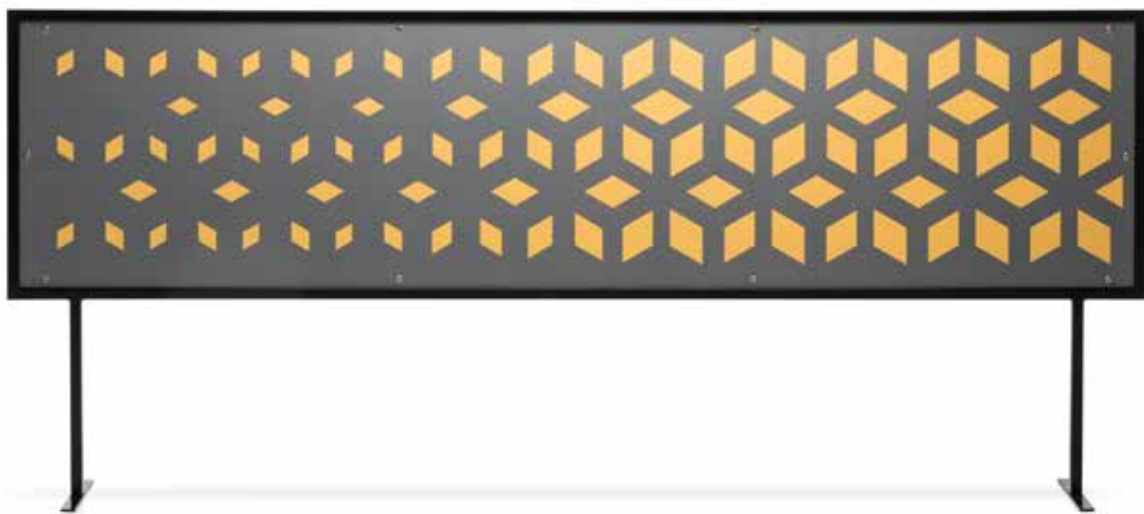
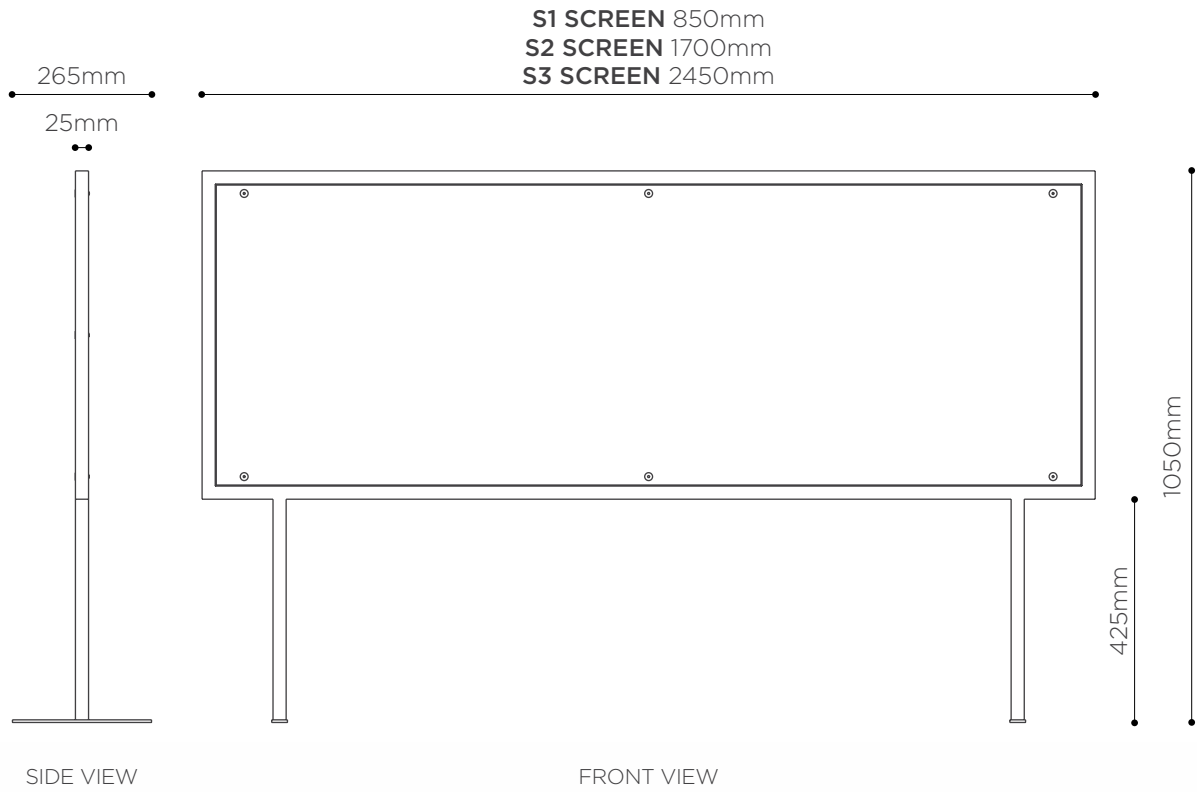





SCREEN MODULES DESIGNS

Nothing makes a bigger visual impact than a beautiful screen. Perforating your ATOMIK Screen creates an effective feature and space solution that won't impede your sight lines. Alternatively keep your screen solid and apply Seraphic Digital Print pattern to your screen finish to create privacy for your seating without enclosing it. Choose from one of our 4 standard patterns below, created to co-ordinate perfectly with the geometric nature of ATOMIK, or chat to us about your custom design concept.

ASIATIC



SHARD



SETRO



PERDITA

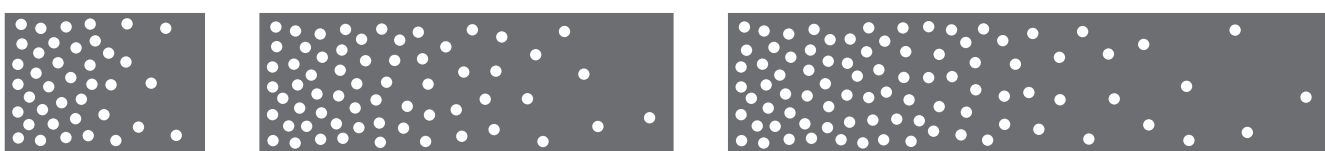

S1

S2

S3



PLUTO GPO

Horizontal surfaces



Pluto satisfies the demand for power and data connectivity in informal spaces. Perfectly suited to breakout areas, smaller meeting rooms and coffee tables, Pluto makes sharing power a pleasure. Studies show that people work far more effectively in small groups and indeed new ideas come from people working in pairs. With 3 outlet positions, Pluto is perfect for a small team to power/charge their devices using conventional mains plugs.

FINISHES

Fascia colour options: white or black

FEATURES

Configure the 3 outlet points as below:

- A. 3 x 5A twin USB fast chargers
- B. 2 x 5A twin USB fast chargers and 1 x Australian GPO plug
- C. 3 x Australian GPO plugs

Twin USB outlets certified to: AS/NZS 60950

GPO certified to: AS/NZS 3112

WARRANTY

1 year

ASSEMBLY

GPO is fitted to your Atomik module by Botton and Gardiner. Connection to the mains by a certified electrician (not included) via a 2000mm lead with standard 10A 3-pin plug or 800mm lead with Elsafe 'J-coupler'

For additional technical information please contact Botton and Gardiner via info@bottonandgardiner.com.au

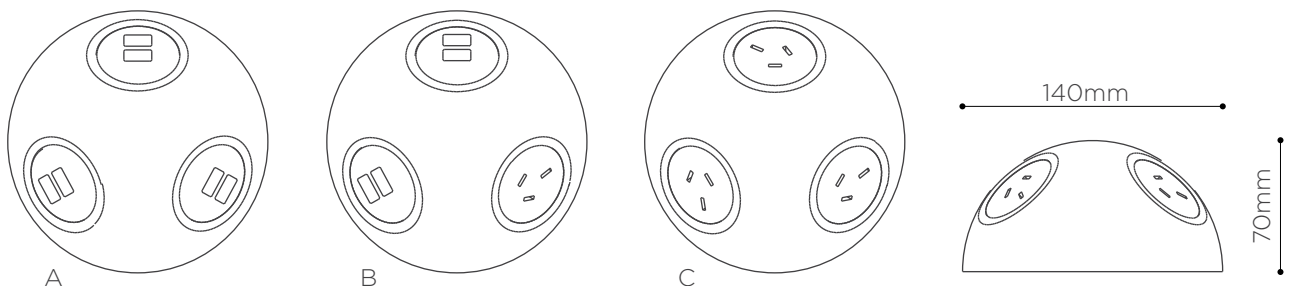



PIXEL GPO

Vertical surfaces



Pixel enables time-short customers to charge their laptop, mobile phone and tablet at the same time! This makes it perfect for drop in areas, airports, shopping centres, universities & hotels. Pixel fits almost flush for a discrete finish and it's unique sweeping organic curves ensure protection against liquid ingress.

FINISHES

Fascia colour options: white or black
Perimeter ring colour: silver

FEATURES

Configured with 1x Australian GPO plug and 1x 5A twin USB fast charger
Twin USB outlets certified to: AS/NZS 60950
GPO certified to: AS/NZS 3112

WARRANTY

1 year

ASSEMBLY

GPO is fitted to your Atomik module by Botton and Gardiner. Connection to the mains by a certified electrician (not included) via a 2000mm lead with standard 10A 3-pin plug or 800mm lead with Elsafe 'J-coupler'

For additional technical information please contact Botton and Gardiner via info@bottonandgardiner.com.au

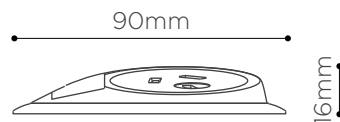
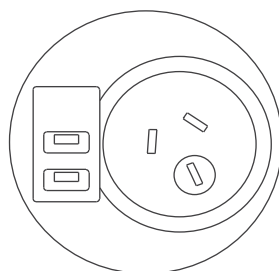

botton + gardiner
PUBLIC SPACE FURNITURE

CONFIGURATION IDEAS



CONFIGURATION IDEAS

ISLANDS

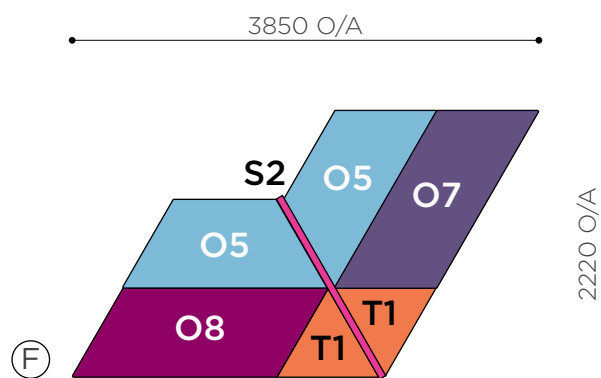
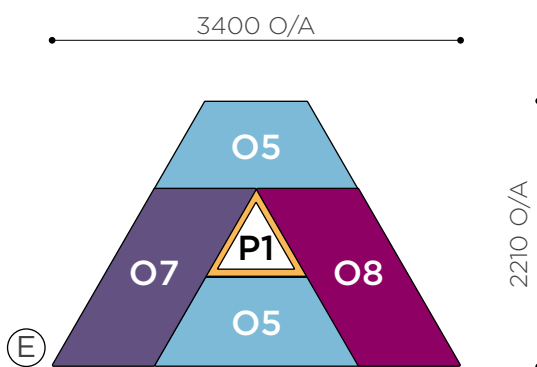
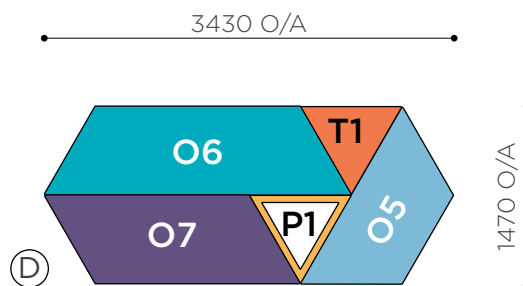
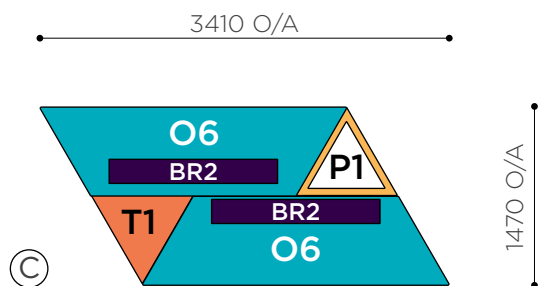
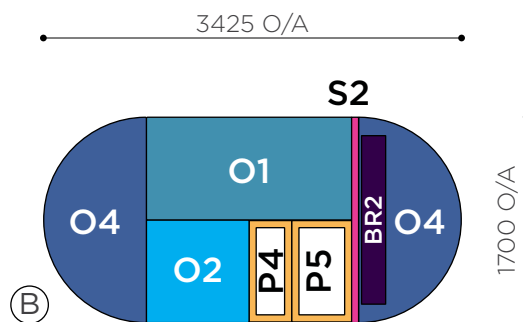
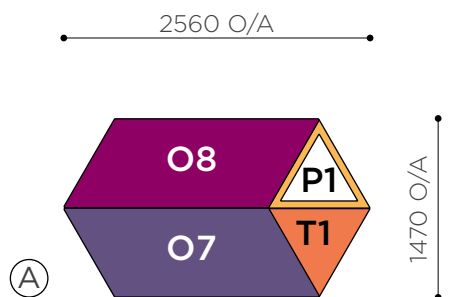

KEY



OTTOMANS PAGES 16 - 19



BACKRESTS PAGES 16 - 19



SCREENS PAGES 26 - 31



TABLES PAGES 20 - 25



PLANTERS PAGES 22 - 25

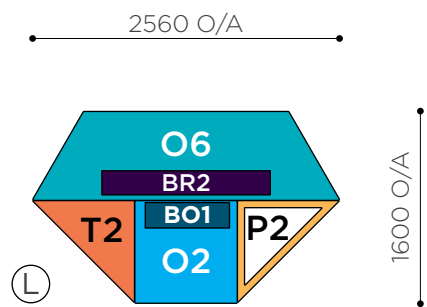
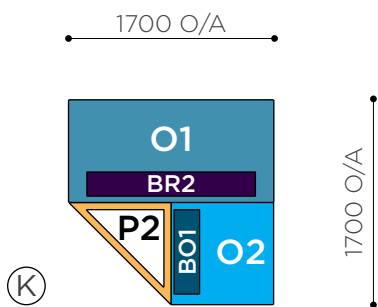
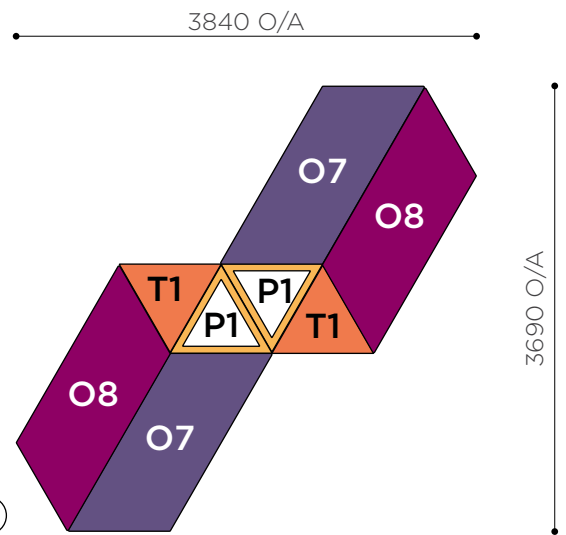
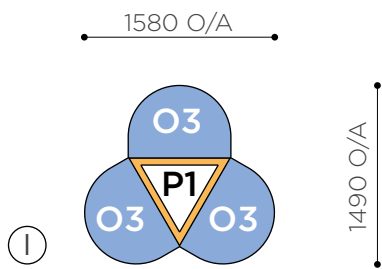
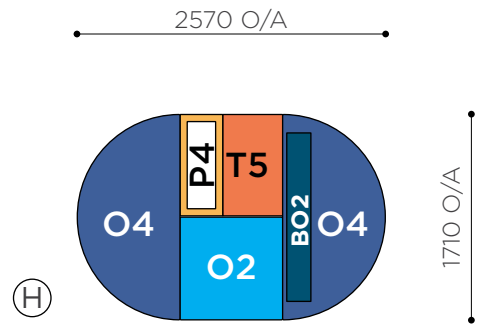
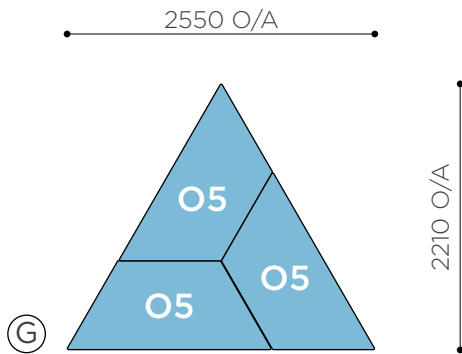

CONFIGURATION IDEAS

BRANCHING

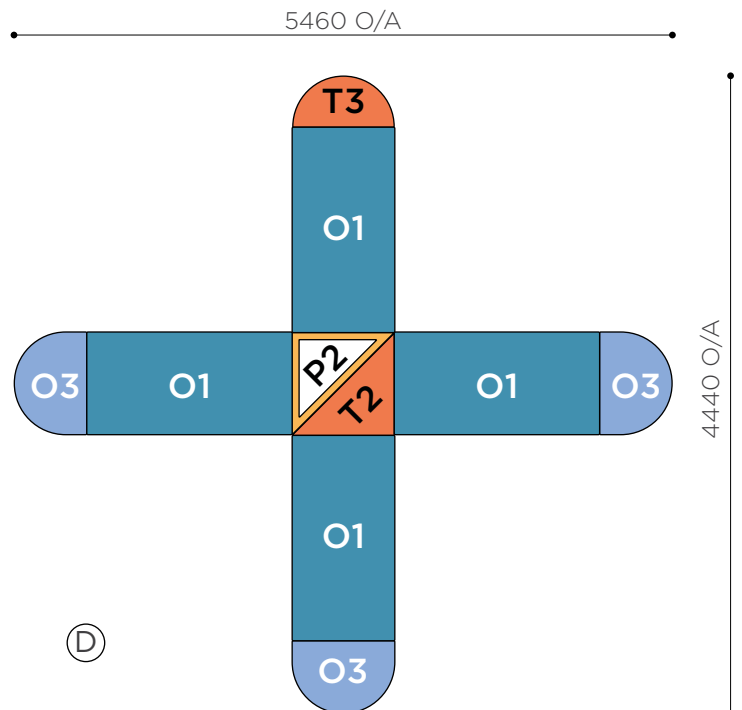
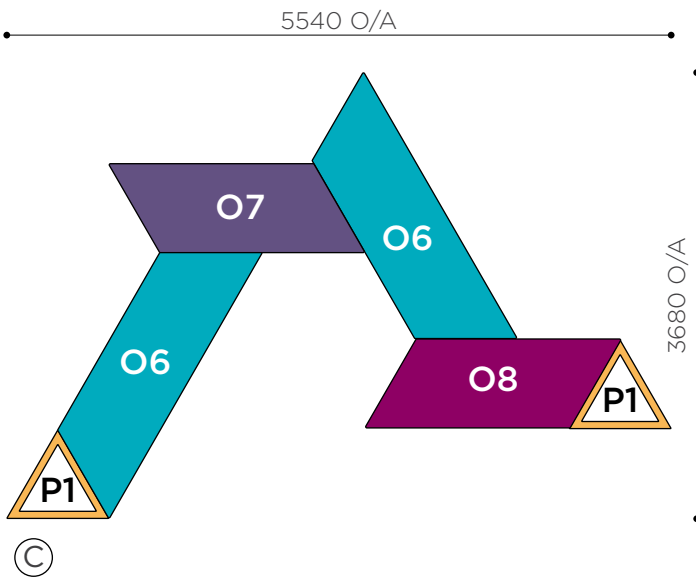
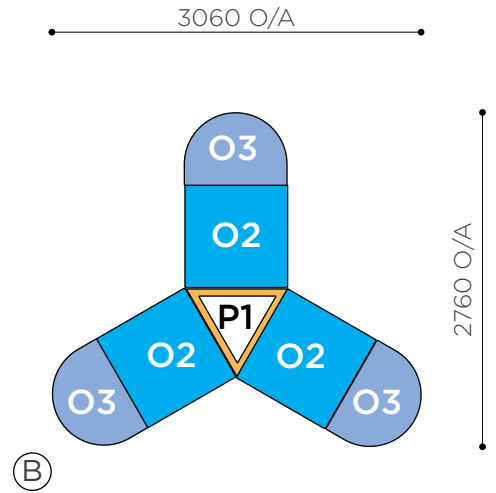
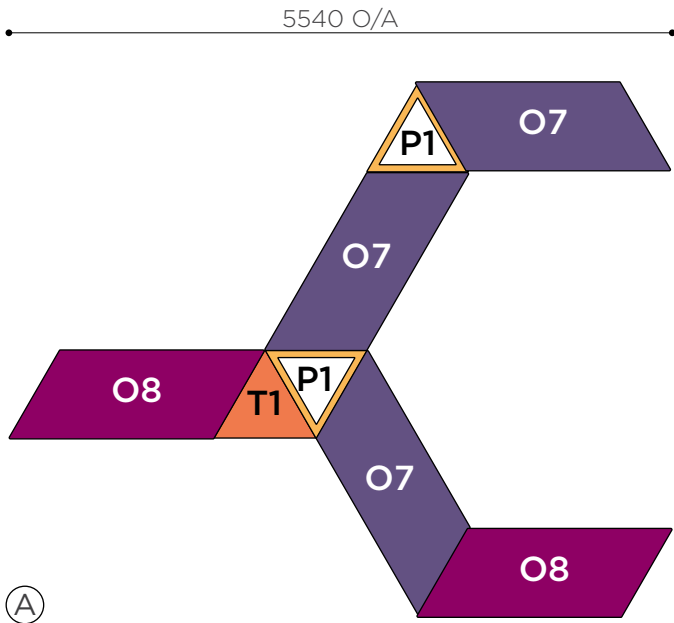

KEY

- O1
- O2
- O3
- O4
- O5
- O6
- O7
- O8
- BR
- BO
- |
- OTTOMANS PAGES 16 - 19
- BACKRESTS PAGES 16 - 19
- SCREENS PAGES 26 - 31

- TABLES PAGES 20 - 25
- PLANTERS PAGES 22 - 25

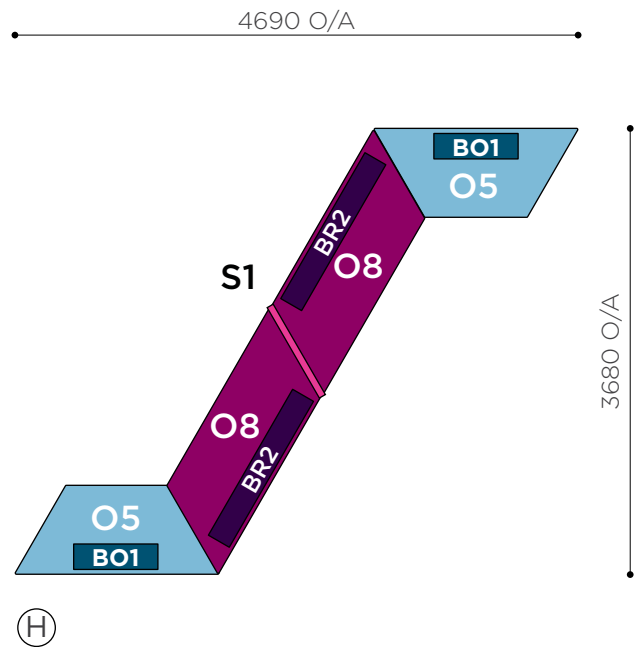
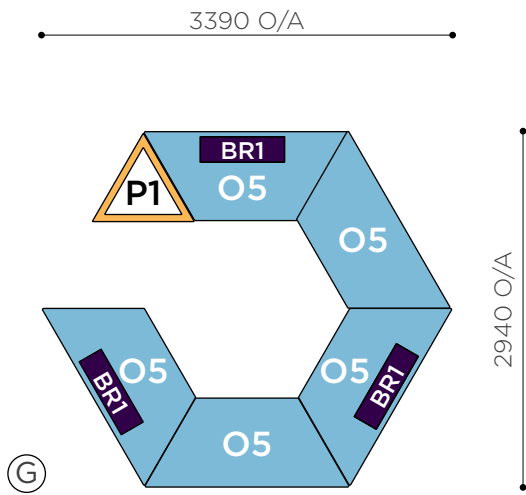
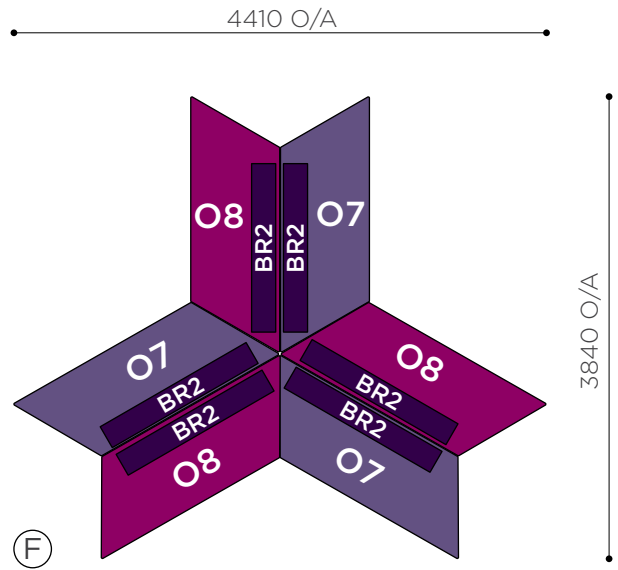
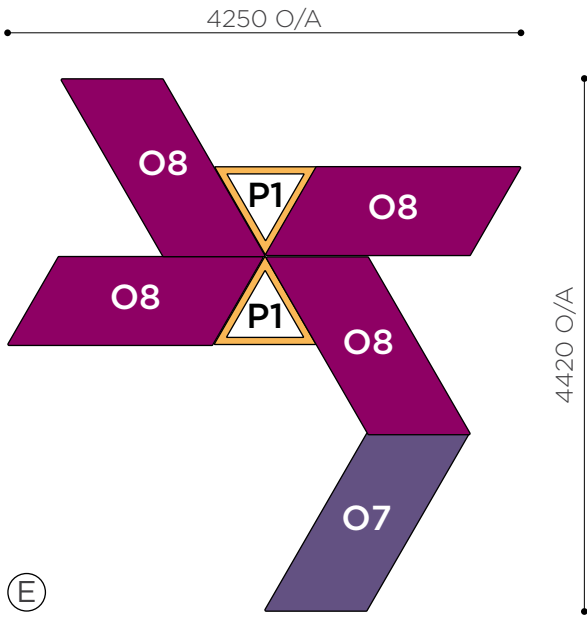

CONFIGURATION IDEAS

STRAIGHT

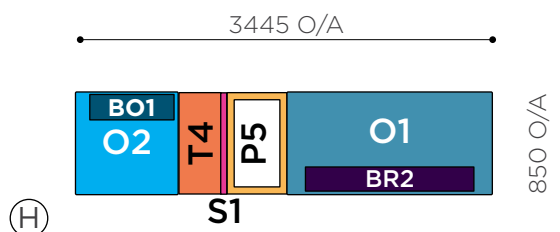
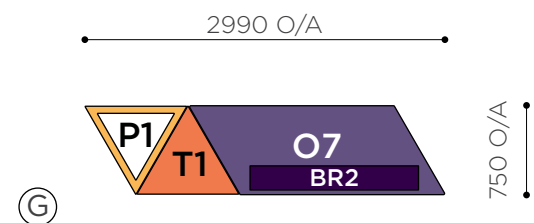
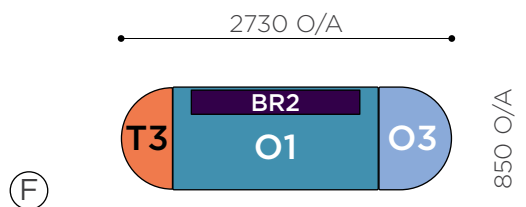
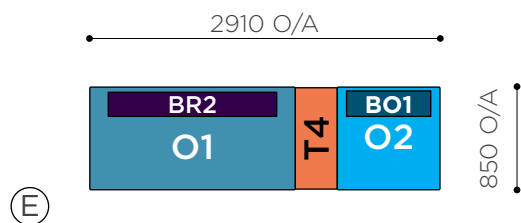
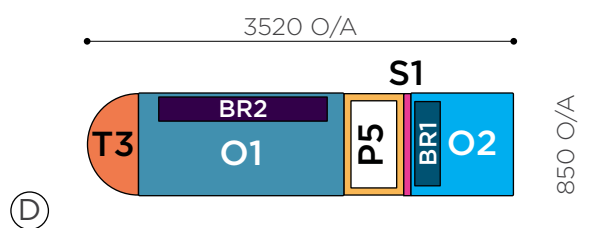
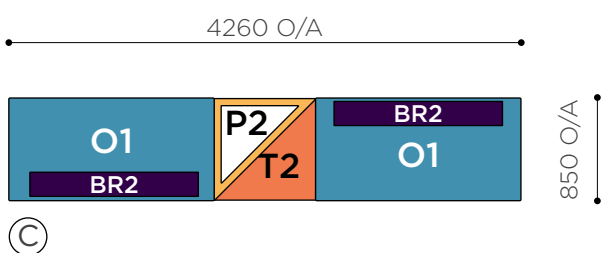
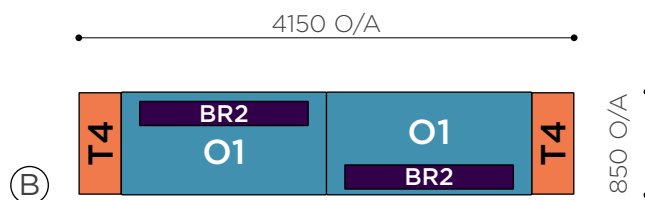
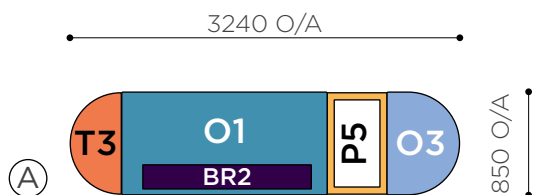

KEY



OTTOMANS PAGES 16 - 19



BACKRESTS PAGES 16 - 19



SCREENS PAGES 26 - 31



TABLES PAGES 20 - 25



PLANTERS PAGES 22 - 25

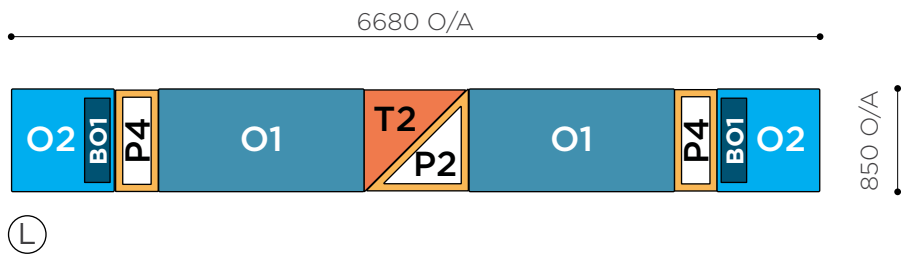
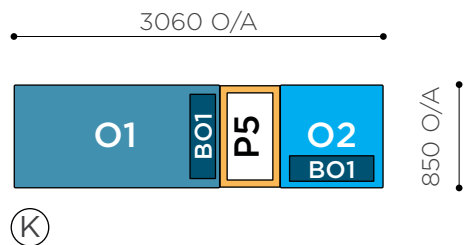
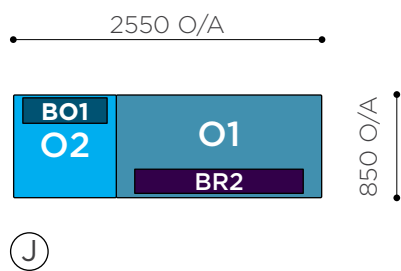
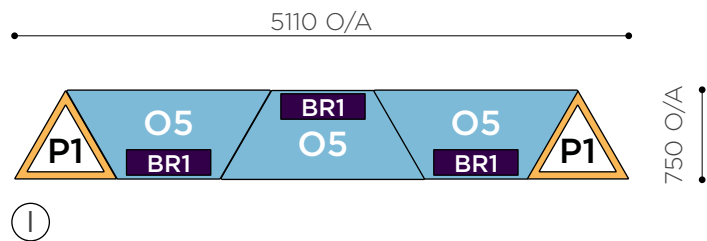

botton + gardiner
PUBLIC SPACE FURNITURE

FINISHES

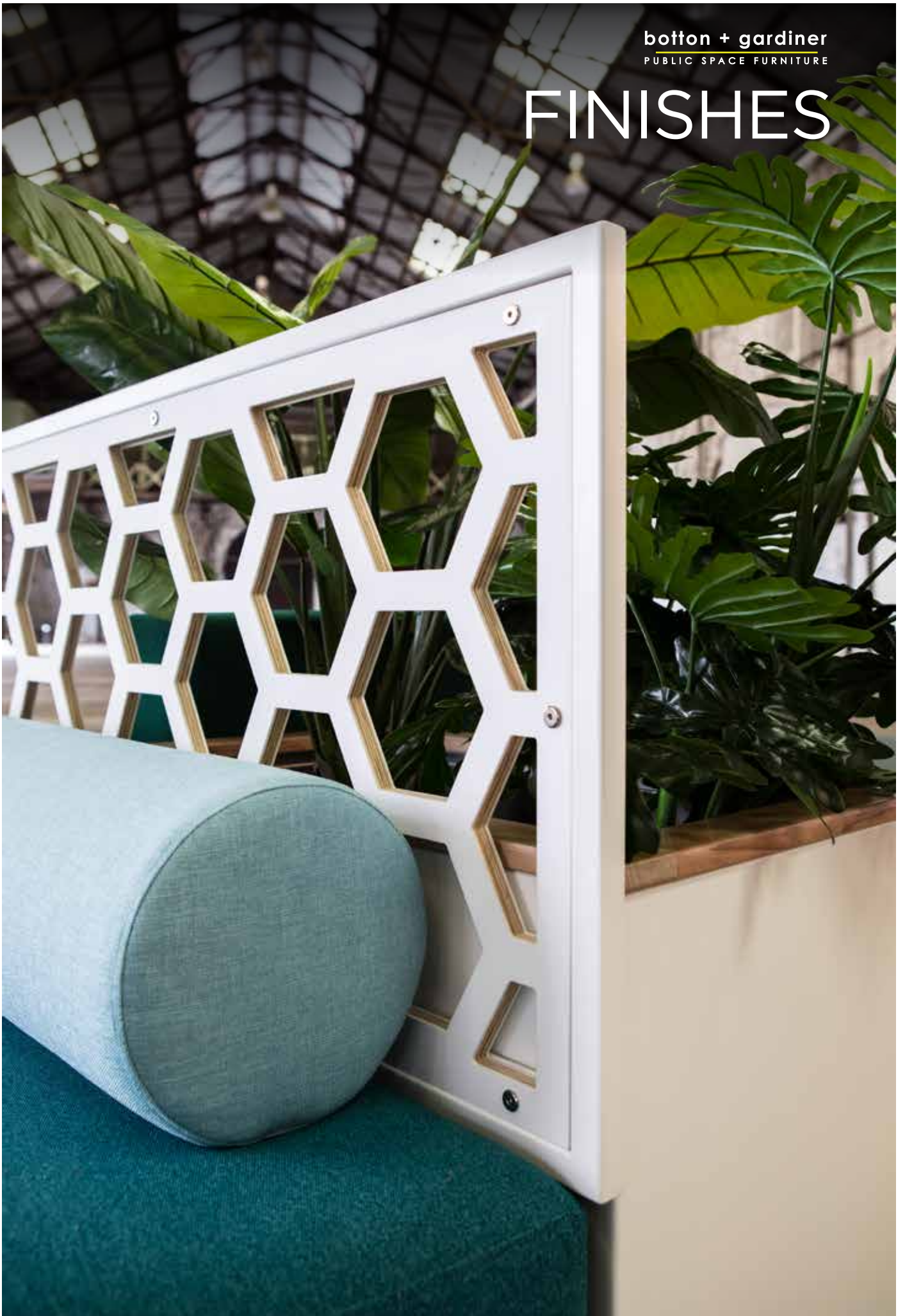

ENGINEERED STONE

Engineered for modern living, our stone combines the beauty and prestige of natural stone with the hard-wearing qualities of quartz. These luxurious surfaces offer high performance with low maintenance and no need for sealing or waxing. Stone surfaces are manufactured with a minimum of 93% quartz which makes the surface highly durable.



ARCADIA



MARENGO



NAXOS



NOMBRE



ATHENA



NERO



CENIZA

CARE + MAINTENANCE

To keep your Engineered Stone clean, simply wipe with a soft cloth and a pH neutral household liquid detergent. Avoid exposure to products with high pH levels / solvents. If your Engineered Stone comes into contact with such products, rinse immediately to neutralise the effect, and then follow usual cleaning procedure.

CORIAN®

Corian® is an elegant decorative material that allows for seamless cladding of surfaces. This hardwearing material stands up well to daily wear and tear and resists most of the impacts, nicks and cuts that occur in heavy traffic areas. Corian® is a refinishable material making it ideal for busy commercial applications.

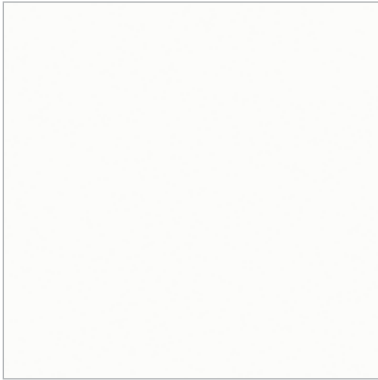

GLACIER WHITE

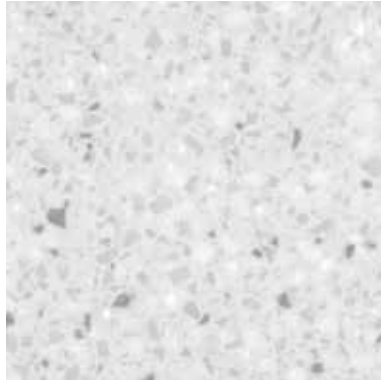

SILVER BIRCH



DOVE



DEEP NIGHT SKY



CLAY

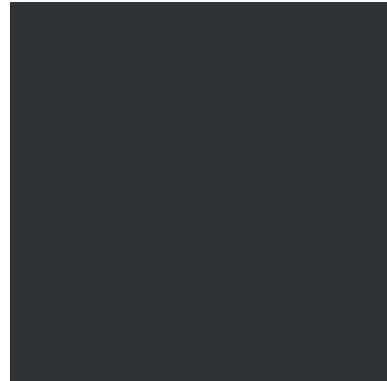

DEEP TITANIUM

CARE + MAINTENANCE

Generally, a damp microfiber cloth used with a standard household kitchen spray should remove most stains.

For most residues, all you need to clean your Corian® is warm soapy water or ammonia-based household cleaner. DO NOT use window cleaners as they can leave a waxy build-up that dulls the surface. Always clean using a circular motion.

If water is left to dry on the surface, film will build up dulling the surface making the finish appear blotchy and uneven. To prevent film build-up, try to wipe completely dry immediately after spills and cleaning.



corian.

AUSTRALIAN HARDWOOD

Our hardwoods are locally sourced from sustainably managed Australian regrowth forests. We select timber species that offer a grain structure and density that is ideally suited to a long life in the harsh public environment. In exterior applications the natural beauty of the timber is further enhanced and protected with three coats of exterior grade oil, pigmented for high UV resistance.



LACQUERED VIC ASH
[INTERNAL USE ONLY]

CARE + MAINTENANCE

Wipe down regularly with fresh water and a non-abrasive cloth.

For ongoing maintenance of oiled timbers, lightly sand rough areas of timber and brush on one coat of Sikkens Cetol HLS in the correct colour every 6 months or as required.

COMPACT LAMINATE [Internal Use]

Compact Laminate with Protect+™ anti-microbial surface performance is strong, durable and moisture resistant, making it suitable for a wide variety of uses. This versatile material requires no additional finish.

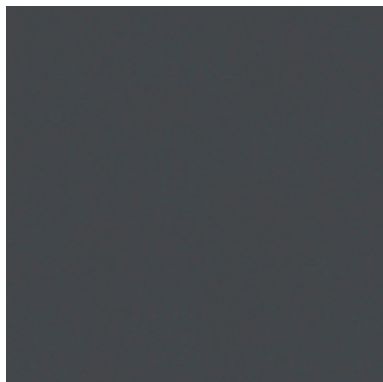

CHARCOAL

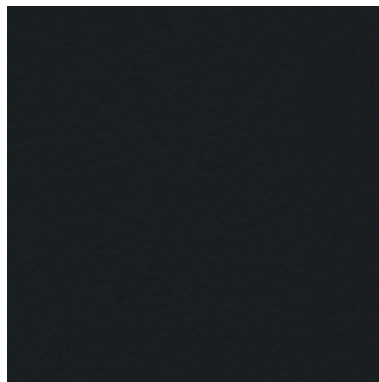

BLACK



BLACKENED LINEWOOD



LICORICE LINEA



ALASKAN



JERICO



SUBLIME TEAK

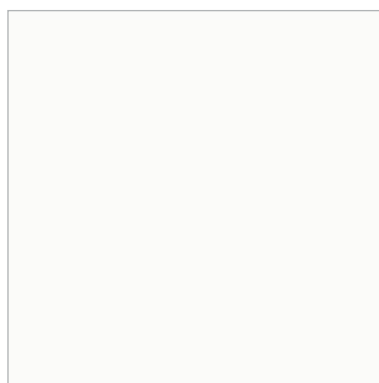

WHITE



SEASONED OAK

CARE + MAINTENANCE

For general care and maintenance, simply wipe away most spills or marks with a damp microfibre cloth, or use an all purpose cleaner such as Windex spray cleaner or Ajax Spray n Wipe. Rubbing gently with a clean, dry cloth brings back the brightness of laminates. DO NOT use abrasive or polishing materials.

POWDERCOATS - BOTTON + GARDINER

Powdercoating gives a uniform, durable, high quality and attractive finish that is low in VOCs. As well as being better for the environment, powdercoated surfaces are more resistant to chipping, scratching, fading and wearing than its alternatives. This cost-effective finish has great UV resistance and durability in the elements.

Custom colours can be specified from Interpon, Dulux or Oxytech locally available colour ranges. Custom colours will incur an additional set-up fee. Specialty powdercoats (i.e. ripple, metallics, pearl etc.) to be quoted upon selection as additional set-up charges may apply. Minimum quantity fees apply for powdercoating small orders in both custom and standard colours.

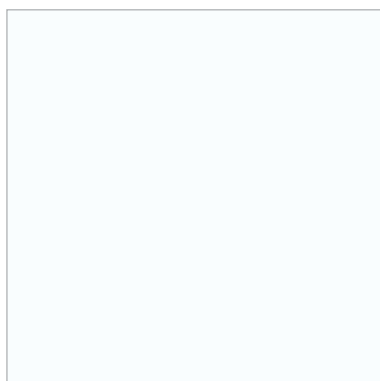

PEARL WHITE GLOSS

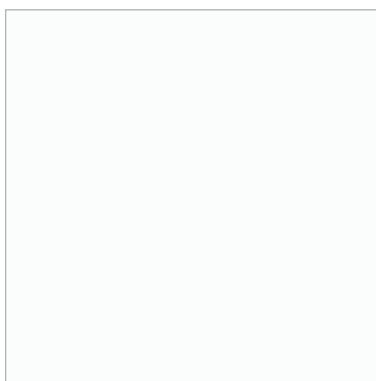

WHITE SATIN



BLACK SATIN

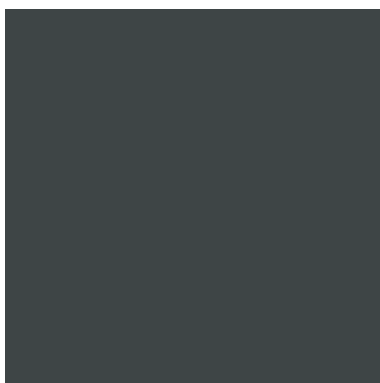

CHARCOAL SATIN



BLACK MATT



PALLADIUM SILVER

CARE + MAINTENANCE

1. Carefully remove any loose surface deposits with a wet sponge.
2. Use a soft (non abrasive) cloth or brush and a diluted solution of mild detergent and water (DO NOT use solvents) to remove dust, salt and other deposits.
3. Ensure surfaces are thoroughly rinsed with clean fresh water after cleaning to remove all residues.

ZINTRA® ACOUSTIC PANEL

Baresque's Zintra Acoustic Panel is the perfect solution for your application where acoustic performance as well as aesthetics are required. Zintra is available in a wide range of bright and neutral colours, it is pinnable, and able to be perforated if you require visibility through the screen, making it the ideal material for office, hospitality and educational projects.

Zintra is available with or without Seraphic High Performance Digital Print. For plain colours, choose from our standard colour range, featured below. If you are after something a bit different, the flexibility and virtually limitless design options available with Seraphic Digital Print makes the world your oyster in terms of what can be achieved, see page 53 for further information.



NAVY A01



BLUE A14



LIME A43*



BLUSH A08



ORANGE A46



YELLOW A05



COCOA A39



MILKY WHITE



BLACK A13



ASH A03



GREY A36



SILVER A11



PERIWINKLE A30



WHITE A07



CREAM A04



TAUPE A12*

CARE + MAINTENANCE

Remove spills immediately using damp, clean cloth.

A fabric lint brush or soft head on a vacuum cleaner may be used to remove dust.

Carpet and fabric cleaners can be used, always test in an inconspicuous area first.

For additional technical information please search for Zintra at baresque.com.au

LIGHTBLOCKS BOARD

Lightblocks Board is a fully refinishable, finger print proof resin with a soft touch. It has a matt finish and is bleach cleanable. Suitable for indoor applications only. Lightblocks Board is also available with Seraphic Digital Print. See next page for details.



CARE + MAINTENANCE

- Use warm water, mild detergent, and a soft sponge, cloth, or chamois to clean Lightblocks
- Surface contamination may be cleaned using kerosene, hexane, or aliphatic naphtha, or any acrylic cleaner, such as Novus. Always follow manufacturer's recommended use and safety procedures
- DO NOT use glass cleaning products, acetone, gasoline, benzene, lacquer thinner, chlorinated solvents, gritty abrasive scouring compounds, or alkaline cleaners to clean Lightblocks as damage to the sheet will occur
- Remove any oily residue left behind from solvent cleaning with detergent and water
- Do not use squeegee, scraper, or synthetic rags that may scratch Lightblocks
- When cleaning, never scrub Lightblocks. Gently wipe surface with a soft scratch free cloth

REFINISHING

- Light refinishing - if there is only a light scratch, refinishing can be achieved by using rubbing the area in a random circular motion with a fine steel scouring pad (Scotch-brite). Test in an inconspicuous area before attempting a main area on the job.

SERAPHIC HIGH PERFORMANCE DIGITAL PRINT

AVAILABLE ON LIGHTBLOCKS BOARD AND ZINTR[®]A ACOUSTIC PANEL

Perfect for horizontal and vertical surfaces, take your project to the next level with Seraphic High Performance Digital Print. If you are after something a bit different, the flexibility and virtually limitless design options available with Seraphic Digital Print makes the world your oyster in terms of what can be achieved. Available on Lightblocks Board with no need to worry about the print as it is protected by our finger proof, soft touch, matt resin and also on our Zintra[®] Acoustic Panel, if acoustic properties and pinnability are required.



MAKORE



A BREEZE OF PALM LEAVES



DECO-DENT



ANOTHER GENESIS



VERDANT MIST



DAPPLED CERULEAN

Digital Print designs shown are just a taste of what is available. Create your own design or contact botton + gardiner to discuss your design requirements.

For additional technical information please search for Seraphic at baresque.com.au

UPHOLSTERY FABRICS

Our sister company Baresque offers a wide range of well priced, high performance fabrics including Crypton, commercial and vinyl upholsteries.

Check out these swatches for just a few ideas, or call Baresque on 1300 306 399 to find out more.

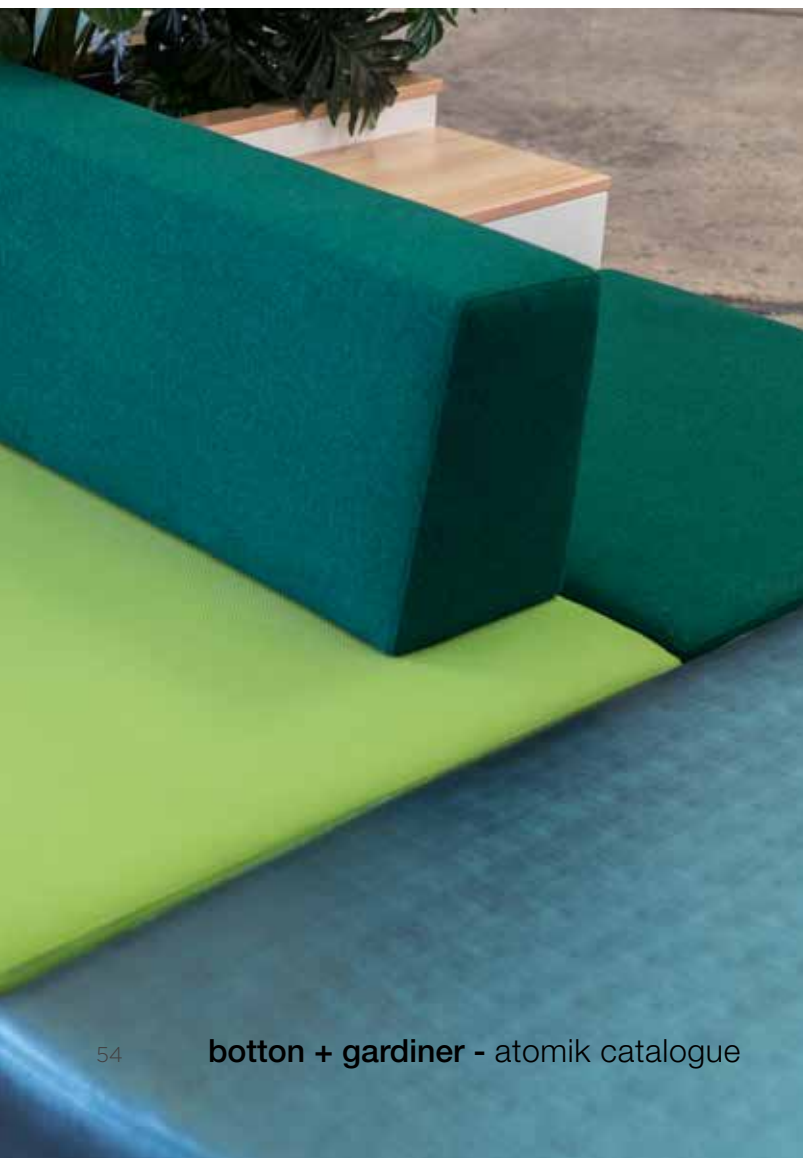



baresque

1300 306 399

baresque.com.au

info@baresque.com.au



botton + gardiner
PUBLIC SPACE FURNITURE

ASSEMBLY INFO

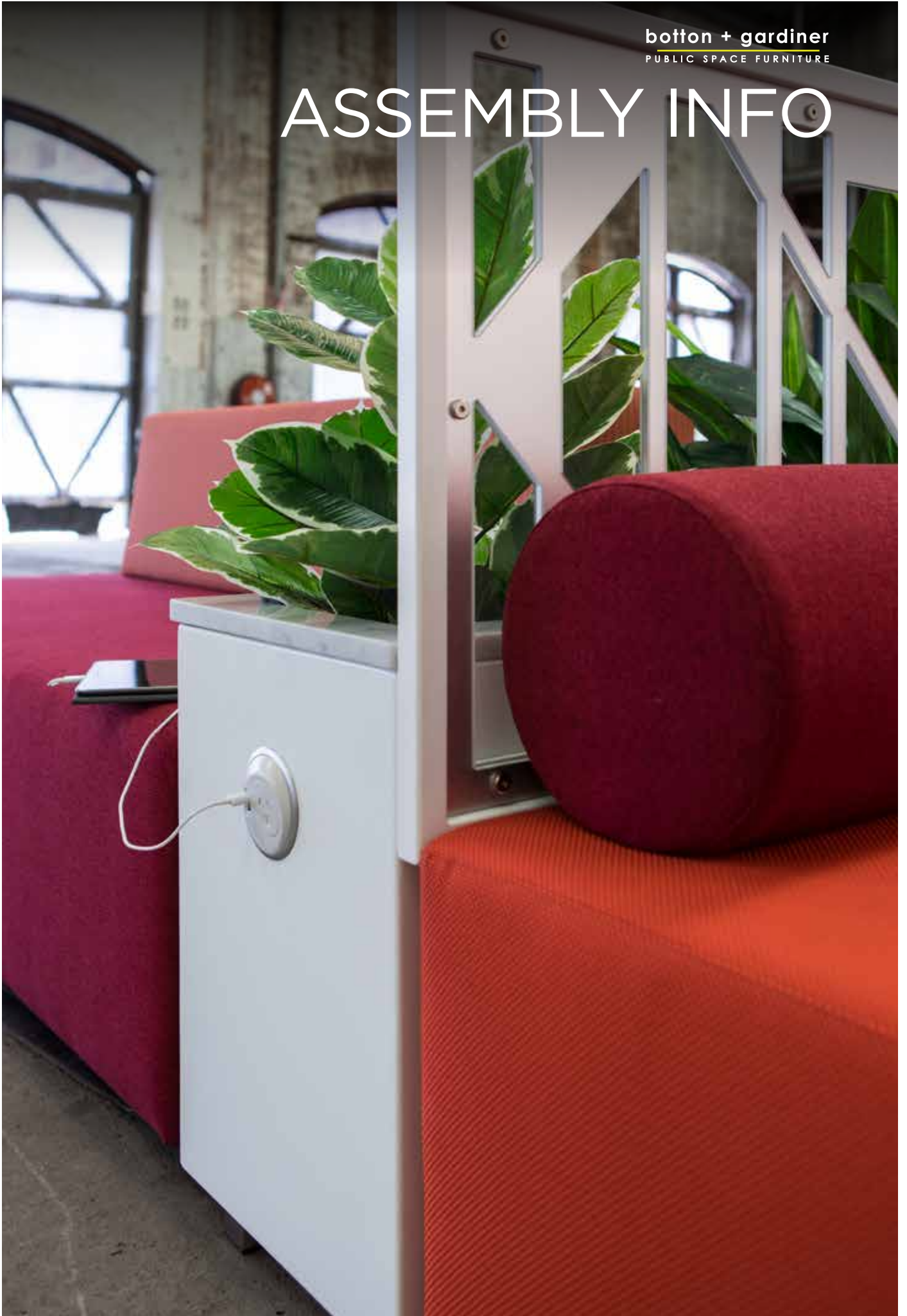

ASSEMBLY INFO

STEP 1

PLACE YOUR MODULE ON IT'S SIDE ON A BLANKET OR SOFT SURFACE. TURN THE CONNECTOR ON THE UNDERSIDE 180 DEGREES (THIS PROTECTS YOUR UPHOLSTERY DURING TRANSPORT)

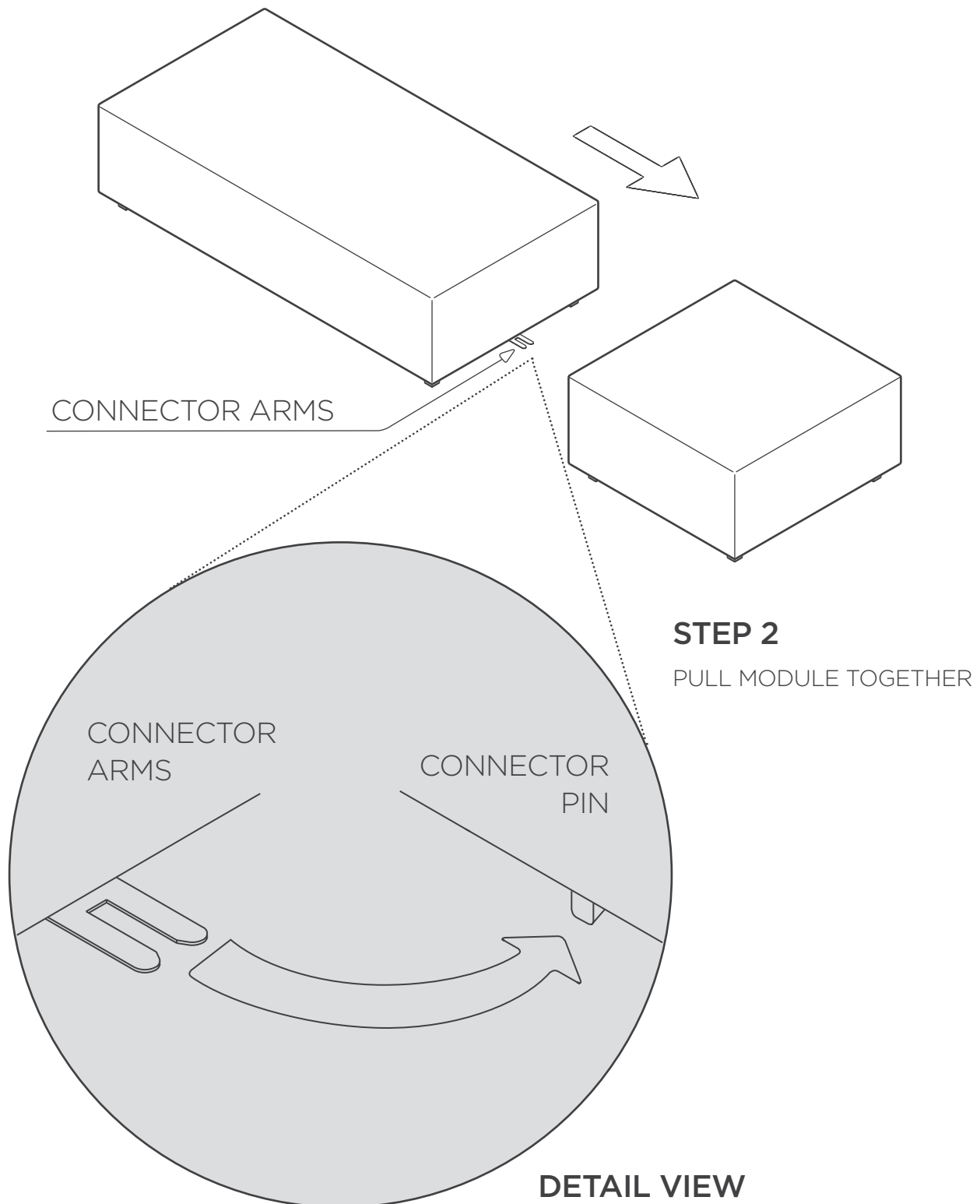

STEP 3

INVISIBLE CONNECTION

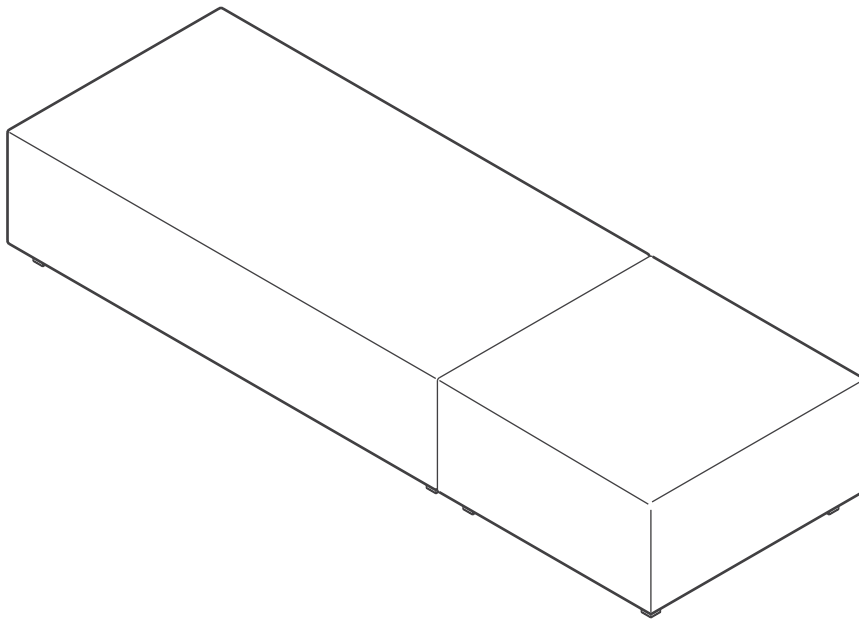

UNITS CAN BE DISASSEMBLED BY LIFTING THE END OF THE MODULE

STEP 4

REPEAT WITH OTHER MODULES IN YOUR POD

botton + gardiner
PUBLIC SPACE FURNITURE

INDEX



FRONT & BACK COVER, 14-15

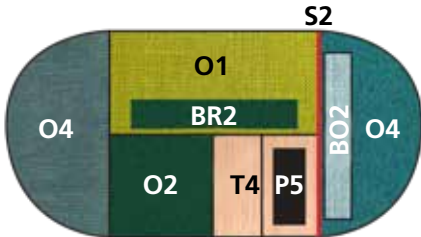

- O1 Rectangle Ottoman
- O2 Square Ottoman
- O4 Large Moon
- O4 Large Moon
- T4 Rectangle Table
- P5 Large Rectangle Planter
- BR2 Backrest 2: 1400mm
- BO2 Bolster 2: 1400mm
- S2 Screen 2: 1700mm

8-9

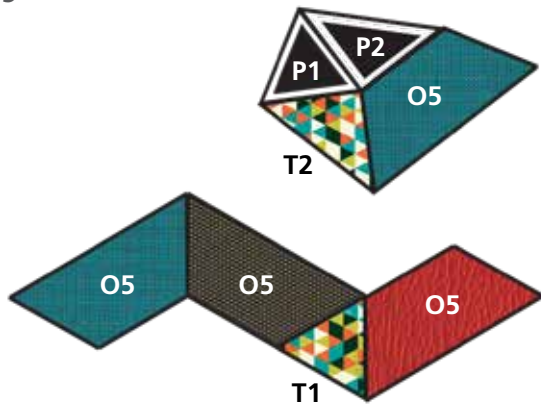

- O5 Small Trapezoid
- O5 Small Trapezoid
- O5 Small Trapezoid
- T1 Equilateral Triangle Table
- T2 Right Angle Triangle Table
- P1 Equilateral Triangle Planter
- P2 Right Angle Triangle Planter

10-11

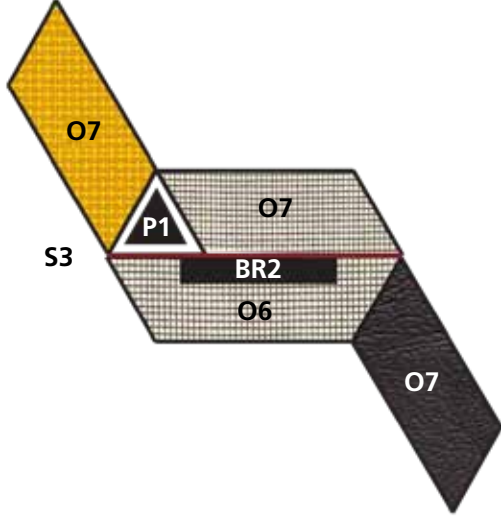

- O6 Large Trapezoid
- O7 Left Parallelogram
- O7 Left Parallelogram
- O7 Left Parallelogram
- P1 Equilateral Triangle Planter
- BR2 Backrest 2: 1400mm
- S3 Screen 3: 2450mm

12-13

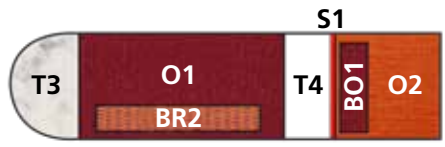

- O1 Rectangle Ottoman
- O2 Square Ottoman
- T3 Small Moon Table
- T4 Rectangle Table
- BO1 Bolster 1: 700mm
- BR2 Backrest 2: 1400mm
- S1 Screen 1: 850mm

Fabric/Top Finish

Frame Finish

Jive, colour: Extra Vert

Outlander, colour: Emerald

Zenus Ascend, colour: Cobalt

Outlander, colour: Aquamarine

Vic Ash Hardwood, clear Polyurethane

Powdercoated Interpon: White Satin

Vic Ash Hardwood, clear Polyurethane

Powdercoated Interpon: White Satin

Outlander, colour: Emerald

Highland, colour: Sky

18mm perforated Lightblocks Board with ply core, White Ice. Asiatic design

Powdercoated Interpon: White Satin

Zoom, colour: Cruise (x2)

Iconic, colour: Mercury

Spirit, colour: Mandarin Orange

Digitally Printed 10mm Lightblocks Board

Powdercoated Interpon: Black Satin

Digitally Printed 10mm Lightblocks Board

Powdercoated Interpon: Black Satin

13mm Laminex Compact Laminate, colour: Polar White

Powdercoated Interpon: White Satin

13mm Laminex Compact Laminate, colour: Polar White

Powdercoated Interpon: White Satin

Zoom, colour: Open Air

Cassidy, colour: Charcoal

Zoom, colour: Open Air

Jive, colour: Buttercup

13mm Laminex Compact Laminate, colour: Polar White

Powdercoated Interpon: Black Satin

Zoom, colour: Open Air

12mm Zintra in White, digitally printed on both sides, Shard design

Powdercoated Interpon: Black Satin

Outlander, colour: Cabernet

Jive, colour: Tigerlily

20mm Smartstone, colour: Athena

Powdercoated Interpon: White Satin

13mm Laminex Compact Laminate, colour: Polar White

Powdercoated Interpon: White Satin

Outlander, colour: Cabernet

Velocity, colour: Siren

12mm perforated Lightblocks Board with white core, Silver. Setro design

Powdercoated Interpon: White Satin

botton + gardiner

PUBLIC SPACE FURNITURE

Ph: 1300 762 701
bottongardiner.com.au



A division of Baresque Australia Pty Ltd

